

**Silicon NPN Power Transistors**

**2SC4510**

**DESCRIPTION**

- With TO-3PML package
- High voltage ,high speed switching
- Low collector saturation voltage

**APPLICATIONS**

- Switching regulators
- DC-DC convertors
- Solid state relay
- General purpose power amplifiers

**PINNING**

PIN	DESCRIPTION
1	Base
2	Collector
3	Emitter

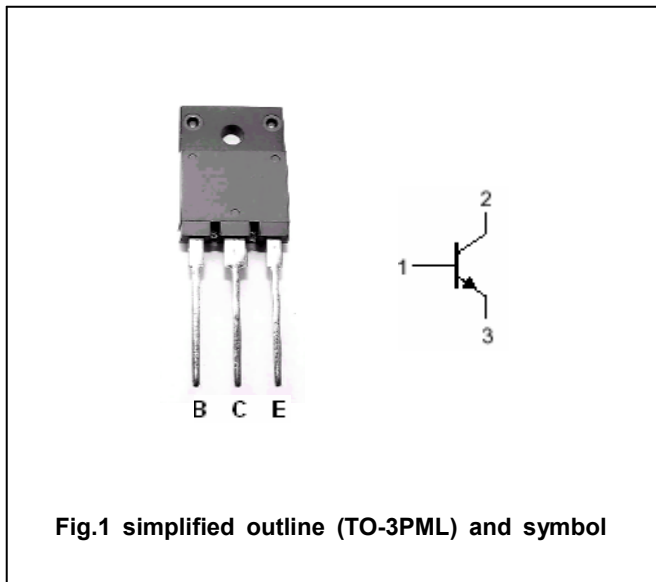

Fig.1 simplified outline (TO-3PML) and symbol

**Absolute maximum ratings(Tc=25°C)**

SYMBOL	PARAMETER	CONDITIONS	VALUE	UNIT
V <sub>CBO</sub>	Collector-base voltage	Open emitter	500	V
V <sub>CEO</sub>	Collector-emitter voltage	Open base	400	V
V <sub>EBO</sub>	Emitter-base voltage	Open collector	10	V
I <sub>C</sub>	Collector current		15	A
I <sub>B</sub>	Base current		5	A
P <sub>C</sub>	Collector power dissipation	T <sub>C</sub> =25°C	80	W
T <sub>j</sub>	Junction temperature		150	°C
T <sub>stg</sub>	Storage temperature		-55~150	°C

**THERMAL CHARACTERISTICS**

SYMBOL	PARAMETER	MAX	UNIT
R <sub>th j-c</sub>	Thermal resistance junction case	1.56	°C/W

## Silicon NPN Power Transistors

## 2SC4510

## CHARACTERISTICS

T<sub>j</sub>=25°C unless otherwise specified

SYMBOL	PARAMETER	CONDITIONS	MIN	TYP.	MAX	UNIT
V <sub>(BR)CBO</sub>	Collector-base breakdown voltage	I <sub>C</sub> =1mA; I <sub>E</sub> =0	500			V
V <sub>CEO(SUS)</sub>	Collector-emitter sustaining voltage	I <sub>C</sub> =0.2A; I <sub>B</sub> =0	400			V
V <sub>(BR)EBO</sub>	Emitter-base breakdown voltage	I <sub>E</sub> =1mA; I <sub>C</sub> =0	10			V
V <sub>CEsat</sub>	Collector-emitter saturation voltage	I <sub>C</sub> =6A; I <sub>B</sub> =1.2A			0.8	V
V <sub>BEsat</sub>	Base-emitter saturation voltage	I <sub>C</sub> =6A; I <sub>B</sub> =1.2A			1.2	V
I <sub>CBO</sub>	Collector cut-off current	V <sub>CB</sub> =450V; I <sub>E</sub> =0			100	μA
I <sub>EBO</sub>	Emitter cut-off current	V <sub>EB</sub> =10V; I <sub>C</sub> =0			100	μA
h <sub>FE</sub>	DC current gain	I <sub>C</sub> =2A; V <sub>CE</sub> =5V	25		65	

## Switching times

t <sub>on</sub>	Turn-on time	I <sub>C</sub> =7.5A; R <sub>L</sub> =20Ω I <sub>B1</sub> =0.75A; I <sub>B2</sub> =-1.5A P <sub>w</sub> = 20μs; Duty≤2%			1.0	μs
t <sub>stg</sub>	Storage time				2.5	μs
t <sub>f</sub>	Fall time				0.5	μs

Silicon NPN Power Transistors

2SC4510

PACKAGE OUTLINE

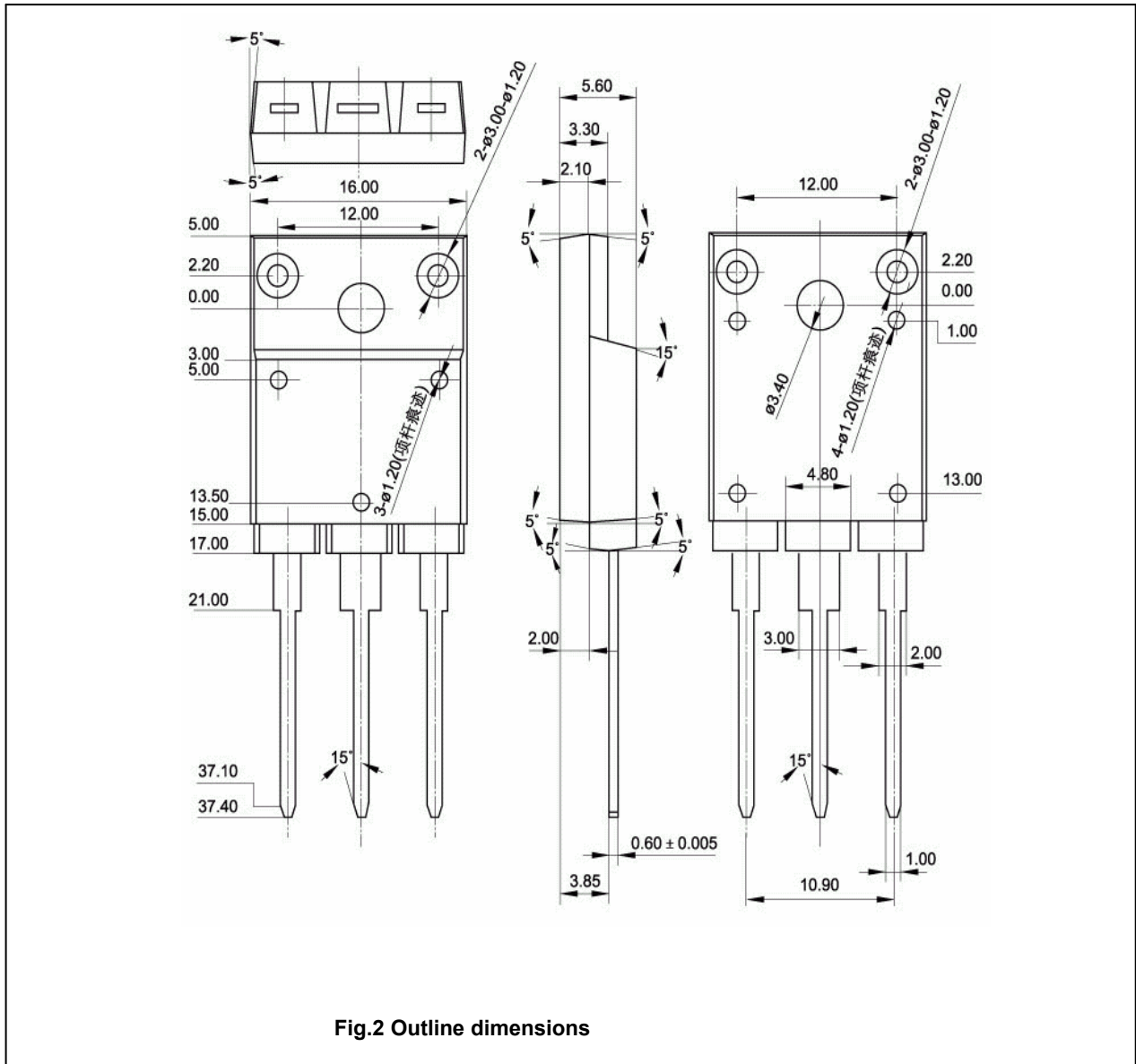

Fig.2 Outline dimensions

Silicon NPN Power Transistors

2SC4510

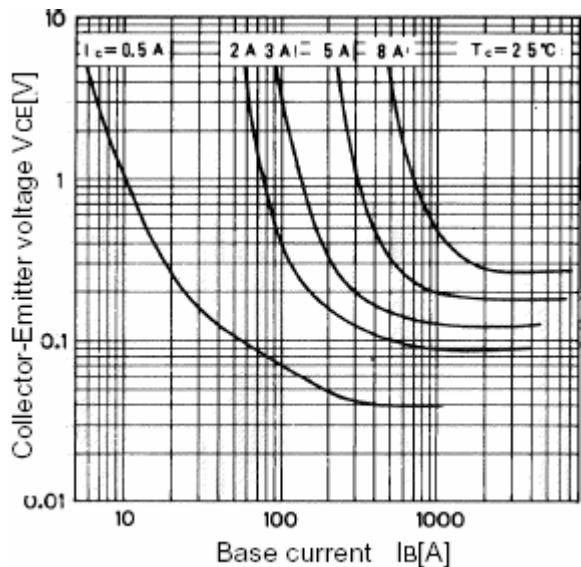

Fig.3 Static Characteristic

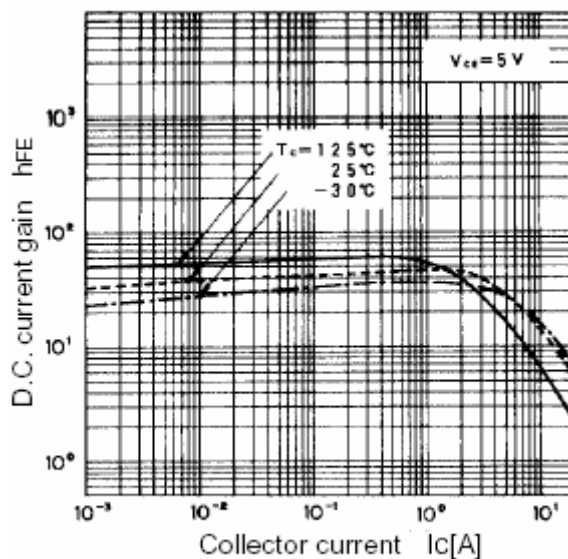

Fig.4 DC current Gain

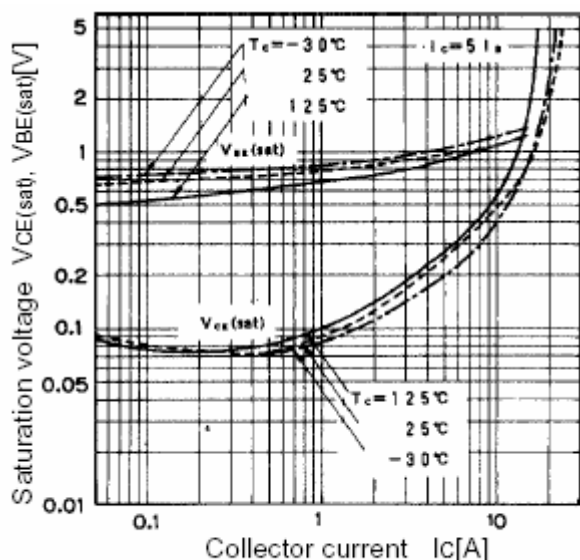

Fig.5 Base-Emitter Saturation Voltage  
Collector-Emitter Saturation Voltage

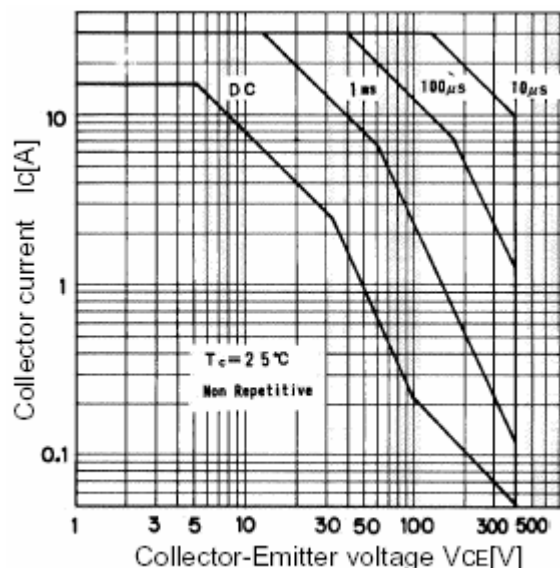

Fig.6 Safe Operating Area