

InGaAs linear image sensor G9211 to G9214/G9205 to G9208 series



Near infrared image sensors (0.9 to 1.67 μm / 2.55 μm)

G9211 to G9214/G9205 to G9208 series InGaAs linear image sensors are specifically designed for near infrared multichannel spectrophotometry. These linear image sensors consist of an InGaAs photodiode array, a charge amplifier array, an offset compensation circuit, a shift register and a timing generator formed on a CMOS chip. The charge amplifier array is made up of CMOS transistors connected to each pixel of the InGaAs photodiode array. Signals from each pixel are read out in charge integration mode to achieve high sensitivity and stable operation in the near infrared spectral range. The package is hermetically sealed for high reliability.

Signal processing circuits on the CMOS chip allow selecting a feedback capacitance (Cf) of 10 pF or 0.5 pF by using an external voltage input. The image sensor operates over a wide dynamic range when Cf=10 pF and delivers high gain when Cf=0.5 pF.

Features

- Wide dynamic range
- Low noise and low dark current
- Selectable gain
- Anti-saturation circuit
- CDS circuit *1
- Offset compensation circuit
- Simple operation (by built-in timing generator) *2
- High resolution: 25 μm pitch (512 ch)
- Low cross-talk
- 256 ch: 1 video line
512 ch: 2 video lines

Applications

- Near infrared multichannel spectrophotometry
- Radiation thermometry
- Non-destructive inspection

Related products

- InGaAs multichannel detector head C8061-01, C8062-01
- Multichannel detector head controller C7557

■ Selection guide

Type No.	Cooling	Number of pixels	Pixel pitch (μm)	Pixel size [μm (H) × μm (V)]	Spectral response range (μm)	Defective pixel
G9211-256S	One-stage TE-cooled	256	50	50 × 250	0.9 to 1.67 (-10 °C)	1 % Max. *3
G9212-512S		512	25	25 × 250		
G9213-256S		256	50	50 × 500		
G9214-512S		512	25	25 × 500		
G9205-256W	Two-stage TE-cooled	256	50	50 × 250	0.9 to 1.85 (-20 °C)	5 % Max.
G9206-256W					0.9 to 2.05 (-20 °C)	
G9207-256W					0.9 to 2.25 (-20 °C)	
G9208-256W					0.9 to 2.55 (-20 °C)	

*1: CDS (Correlated Double Sampling) circuit

A major source of noise in charge amplifiers is the reset noise generated when the integration capacitance is reset. A CDS circuit greatly reduces this reset noise by holding the signal immediately after reset to find the noise differential.

*2: Timing generator

Different signal timings must be properly set in order to operate a shift register. In conventional image sensor operation, external PLDs (Programmable Logic Devices) are used to input the required timing signals. However, G9211 to G9214/G9205 to G9208 series image sensors internally generate all timing signals on the CMOS chip just by supplying CLK and RESET pulses. This makes it simple to set the timings.

*3: Percentage of defective pixels

If your application requires sensors with no defective pixels, please select G9201 series.

■ Spectral response

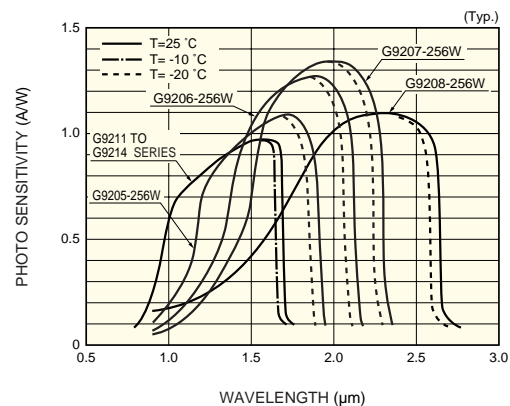

KMIRB0022EB

InGaAs linear image sensor G9211 to G9214/G9205 to G9208 series

Absolute maximum ratings

Parameter	Symbol	Value	Unit
Clock pulse voltage	V_{ϕ}	5.5	V
Operating temperature *4	T_{opr}	-40 to +70	°C
Storage temperature *4	T_{stg}	-40 to +85	°C

*4: Non condensation

Electrical characteristics (Ta=25 °C, V_{ϕ} =5 V)

Parameter	Symbol	Min.	Typ.	Max.	Unit	
Supply voltage	V_{dd}	4.9	5.0	5.1	V	
	V_{ref}	-	1.26	-		
Supply current	I (Vdd)	256 ch	-	45	50	mA
		512 ch	-	90	100	
	I (Vref)	-	1 Max.	-	mA	
Ground	V_{ss}	-	0	-	V	
Element bias	INP	3.5	4.5	4.6	V	
Element bias current	I (INP)	-	1 Max.	-	mA	
Clock frequency	f	0.1	-	4	MHz	
Clock pulse voltage	V_{ϕ}	high	$V_{\phi} - 0.5$	V_{ϕ}	$V_{\phi} + 0.5$	V
		low	0	0	0.4	V
Clock pulse rise/fall times	$t_{r\phi}$	0	20	100	ns	
	$t_{f\phi}$					
Clock pulse width	$t_{pw\phi}$	200	-	-	ns	
Reset pulse voltage	V (RES)	high	$V_{\phi} - 0.5$	V_{ϕ}	$V_{\phi} + 0.5$	V
		low	0	0	0.4	V
Reset pulse rise/fall times	$t_{r(RES)}$	0	20	100	ns	
	$t_{f(RES)}$					
Reset pulse width	$t_{pw(RES)}$	6000	-	-	ns	
Video output voltage	high	V_H	-	4.5	V	
	low	V_L	0	1.26		
Data rate	f_v	-	f/8	-	Hz	

Electrical and optical characteristics (G9211 to G9214 series: T=25 °C, G9205 to G9208 series: T= -20 °C)

Parameter	Symbol	G9211 to G9214 series			G9205 to G9208 series			Unit	
		Min.	Typ.	Max.	Min.	Typ.	Max.		
Peak sensitivity wavelength	λ_p	-	1.55	-	G9205	-	1.75	-	μm
					G9206	-	1.95	-	
					G9207	-	2.05	-	
					G9208	-	2.3	-	
Saturation charge *5	Qsat	-	30	-	-	30	-	pC	
RMS noise voltage (Readout noise)	N	-	180	300	-	180	300	μV_{rms}	
Photo response non-uniformity	PRNU	-	-	± 5 *6	-	-	± 10 *7	%	

*5: $V_{\phi}=5\text{ V}$, $C_f=10\text{ pF}$

*6: 50 % of saturation, integration time: 10 ms, after dark output subtraction, excluding first and last pixels.

*7: 50 % of saturation, integration time: 3 ms, after dark output subtraction, excluding first and last pixels.

Dark current characteristics (T=25 °C)

Parameter	Symbol	Min.	Typ.	Max.	Unit
G9211-256S	I_D	-	2	10	pA
G9212-512S		-	1	5	
G9213-256S		-	4	20	
G9214-512S		-	1	5	
G9205-256W *5		-	15	60	
G9206-256W *5		-	30	120	
G9207-256W *5		-	200	800	
G9208-256W *5		-	500	2000	

*5: $T_D = -20\text{ °C}$

Equivalent circuit

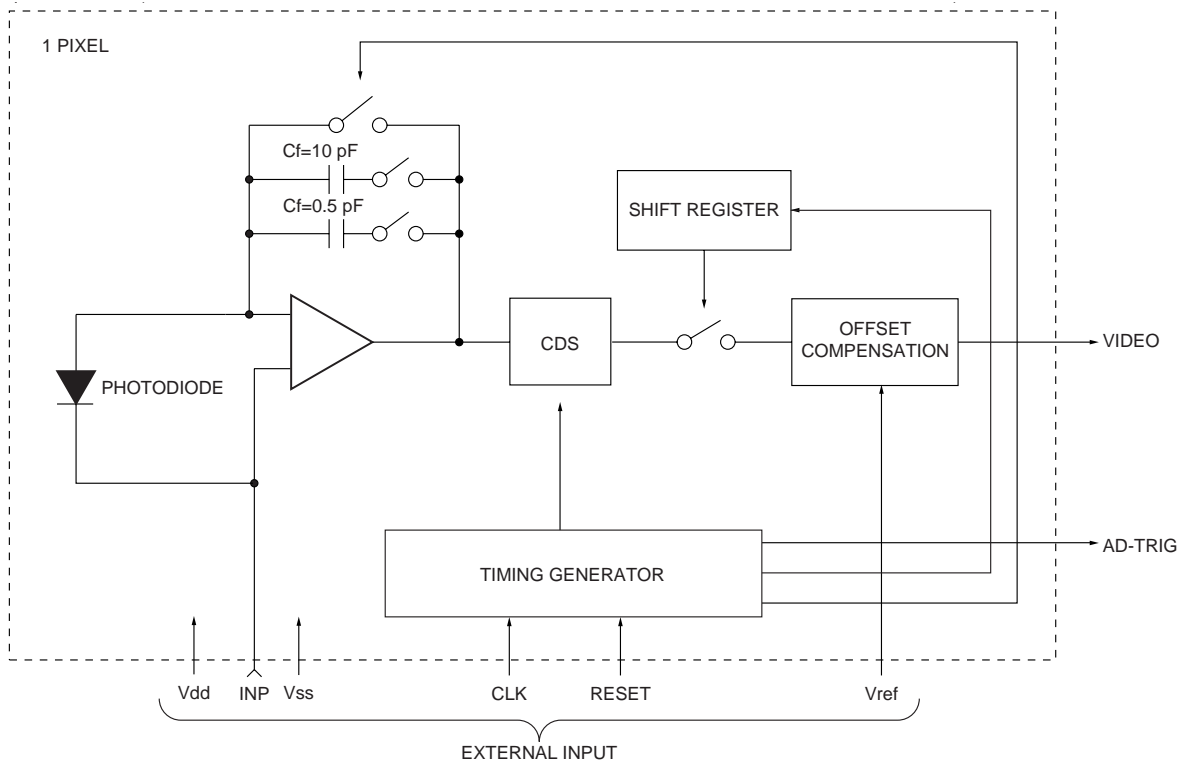

Timing chart

KMIRC0010EB

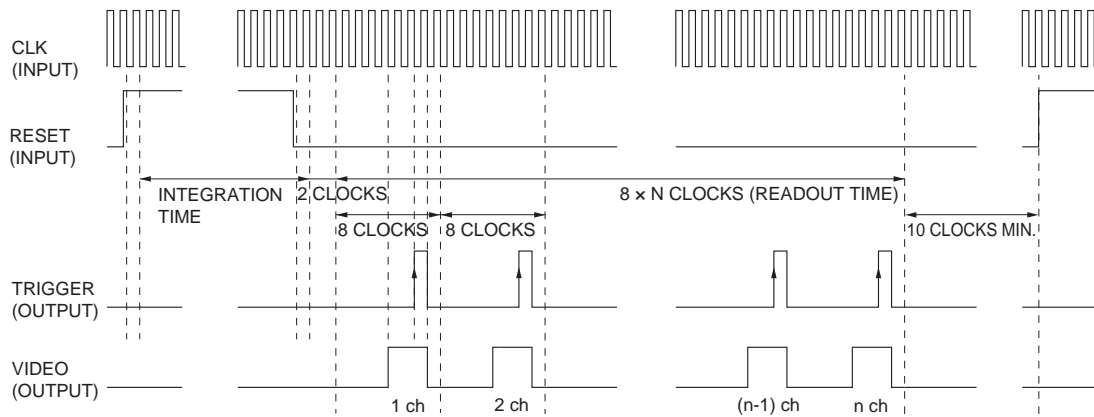

Basic circuit connection

KMIRC0016EA

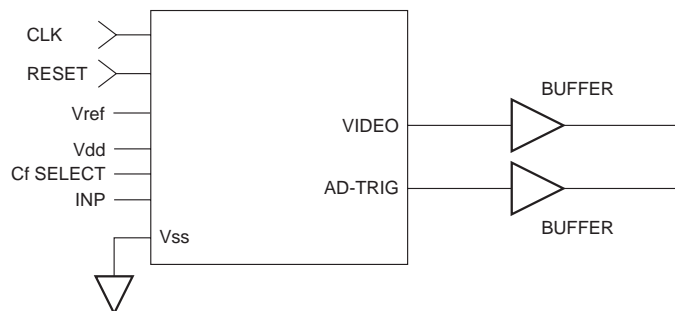

KMIRC0012EA

InGaAs linear image sensor G9211 to G9214/G9205 to G9208 series

Dimensional outline (unit: mm)

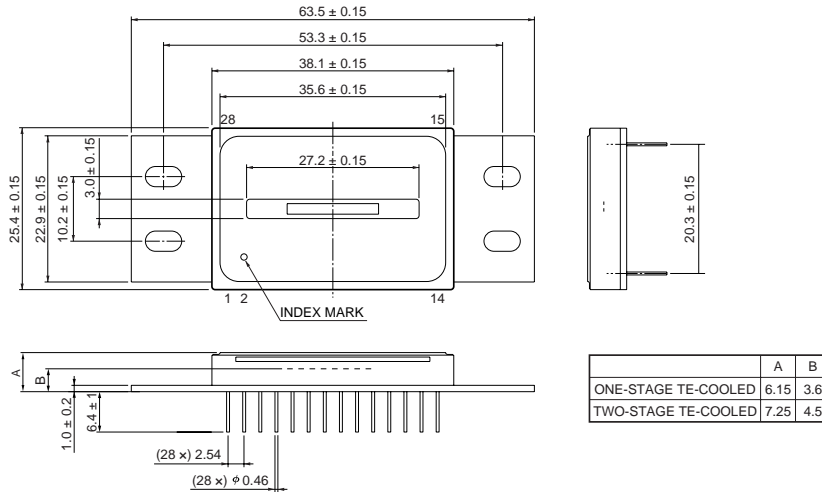

KMIRA0011EA

Pin connection (top view)

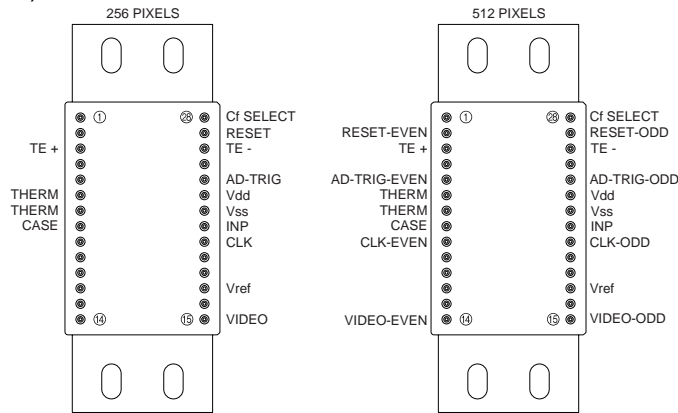

KMIRC0013EA

Terminal name	Input/Output	Function and recommended connection
CLK	Input (CMOS logic compatible)	Clock pulse for operating the CMOS shift register
RESET	Input (CMOS logic compatible)	Reset pulse for initializing the feedback capacitance in the charge amplifier formed on the CMOS chip. The width of the reset pulse is integration time.
Vdd	Input	Supply voltage for operating the signal processing circuit on the CMOS chip.
Vss	-	Ground for the signal processing circuit on the CMOS chip.
INP	Input	Reset voltage for the charge amplifier array on the CMOS chip.
Cf SELECT	Input	Voltage that determines the feedback capacitance (Cf) on the CMOS chip. Cf=10 pF at 0 V, and Cf=0.5 pF at 5 V.
CASE	-	This terminal is electrically connected to the package.
THERM	-	Thermistor for monitoring temperature inside the package.
TE+, TE-	-	Power supply terminal for the thermoelectric cooler that cools the photodiode array. No connection for room temperature operation type.
AD-TRIG	Output	Digital signal for AD conversion; positive polarity
VIDEO	Output	Analog video signal; positive polarity
Vref	Input	Reset voltage for the offset compensation circuit at the CMOS chip

HAMAMATSU

Information furnished by HAMAMATSU is believed to be reliable. However, no responsibility is assumed for possible inaccuracies or omissions. Specifications are subject to change without notice. No patent rights are granted to any of the circuits described herein. ©2005 Hamamatsu Photonics K.K.

HAMAMATSU PHOTONICS K.K., Solid State Division

1126-1 Ichino-cho, Higashi-ku, Hamamatsu City, 435-8558 Japan, Telephone: (81) 53-434-3311, Fax: (81) 53-434-5184, <http://www.hamamatsu.com>

U.S.A.: Hamamatsu Corporation: 360 Foothill Road, P.O.Box 6910, Bridgewater, N.J. 08807-0910, U.S.A., Telephone: (1) 908-231-0960, Fax: (1) 908-231-1218

Germany: Hamamatsu Photonics Deutschland GmbH: Arzbergerstr. 10, D-82211 Herrsching am Ammersee, Germany, Telephone: (49) 08152-3750, Fax: (49) 08152-2658

France: Hamamatsu Photonics France S.A.R.L.: 19, Rue du Saule Trapu, Parc du Moulin de Massy, 91882 Massy Cedex, France, Telephone: 33-(1) 69 53 71 00, Fax: 33-(1) 69 53 71 10

United Kingdom: Hamamatsu Photonics UK Limited: 2 Howard Court, 10 Tewin Road, Welwyn Garden City, Hertfordshire AL7 1BW, United Kingdom, Telephone: (44) 1707-294888, Fax: (44) 1707-325777

North Europe: Hamamatsu Photonics Norden AB: Smidesvägen 12, SE-171 41 Solna, Sweden, Telephone: (46) 8-509-031-00, Fax: (46) 8-509-031-01

Italy: Hamamatsu Photonics Italia S.R.L.: Strada della Moia, 1/E, 20020 Arese, (Milano), Italy, Telephone: (39) 02-935-81-733, Fax: (39) 02-935-81-741

Cat. No. KMIR1011E05
May 2005 DN