

Preliminary Data Sheet

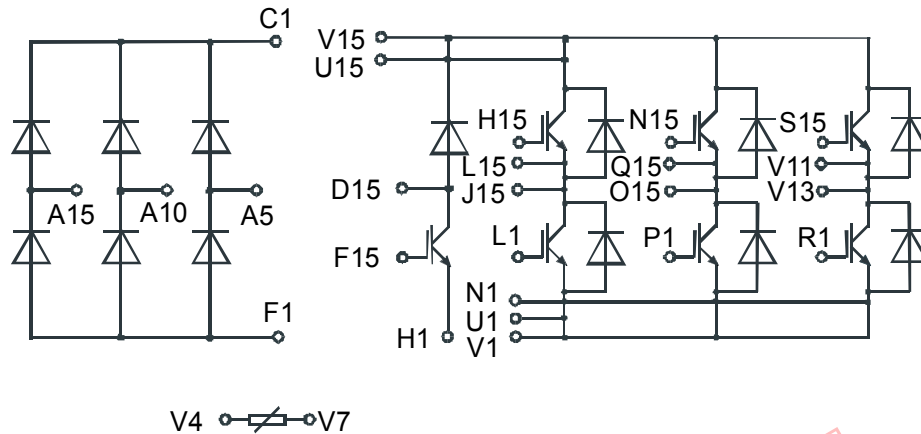

Three Phase Rectifier	Brake Chopper	Three Phase Inverter
$V_{RRM} = 1600\text{ V}$	$V_{CES} = 1200\text{ V}$	$V_{CES} = 1200\text{ V}$
$I_{FAVM} = 68\text{ A}$	$I_{C25} = 30\text{ A}$	$I_{C25} = 49\text{ A}$
$I_{FSM} = 300\text{ A}$	$V_{CE(sat)} = 2.6\text{ V}$	$V_{CE(sat)} = 3.1\text{ V}$

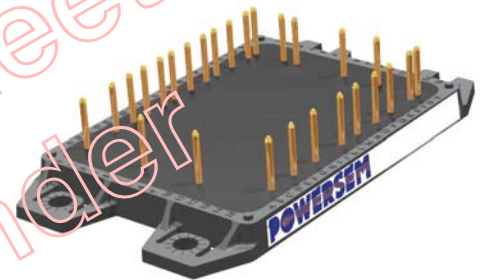

ECO-TOP™ 1

Input Rectifiers

Symbol	Test Conditions	Maximum Ratings	Features
I_{dAV}^*	$T_C = 100\text{ }^\circ\text{C}$, (per circuit)	68 A	<ul style="list-style-type: none"> • Package with DCB ceramic base plate • High level of integration - only one power semiconductor module required for the whole drive • Planar glass passivated chips • NPT IGBT technology with low saturation voltage, low switching losses, high RBSOA and short circuit ruggedness • Epitaxial free wheeling diodes with hipersfast and soft reverse recovery • Temperature sense included • Leads suitable for PC board soldering • UL Release applied
I_{FSM}	$T_{VJ} = 25\text{ }^\circ\text{C}$; $t = 10\text{ ms}$; sin 50 Hz	300 A	
V_{RRM}		1600 V	

Symbol	Test Conditions	Characteristic Value
I_R	$V_R = V_{RRM}$, $T_{VJ} = T_{VJM}$	$\leq 3\text{ mA}$
	$V_R = V_{RRM}$, $T_{VJ} = 25\text{ }^\circ\text{C}$	$\leq 0.5\text{ mA}$
V_F	$I_F = 55\text{ A}$, $T_{VJ} = 25\text{ }^\circ\text{C}$	$\leq 1.46\text{ V}$
V_{TO}	For power-loss calculations only	0.8 V
r_T		13 mΩ
R_{thJC}	per diode; DC	1.1 K/W

Caution: These Devices are sensitive to electrostatic discharge. Users should observe proper ESD handling precautions.

Application: AC motor drives with

- Input from single or three phase grid
- Three phase synchronous or asynchronous motor
- Electric braking operations

Output Inverter IGBTs

Symbol	Conditions	Maximum Ratings	
V_{CES}	$T_{VJ} = 25^{\circ}\text{C}$ to 150°C	1200	V
V_{GES}		± 20	V
I_{C25}	$T_C = 25^{\circ}\text{C}$	49	A
I_{C80}	$T_C = 80^{\circ}\text{C}$	33	A
I_{CM} V_{CEK}	$V_{GE} = \pm 15\text{ V}$; $R_G = 47\ \Omega$; $T_{VJ} = 125^{\circ}\text{C}$ RBSOA, Clamped inductive load; $L = 100\ \mu\text{H}$	50	A
		V_{CES}	
t_{SC} (SCSOA)	$V_{CE} = V_{CES}$; $V_{GE} = \pm 15\text{ V}$; $R_G = 47\ \Omega$; $T_{VJ} = 125^{\circ}\text{C}$ non-repetitive	10	μs
P_{tot}	$T_C = 25^{\circ}\text{C}$	208	W

Symbol	Conditions	Characteristic Values ($T_{VJ} = 25^{\circ}\text{C}$, unless otherwise specified)		
		min.	typ.	max.
$V_{CE(sat)}$	$I_C = 50\text{ A}$; $V_{GE} = 15\text{ V}$; $T_{VJ} = 25^{\circ}\text{C}$ $T_{VJ} = 125^{\circ}\text{C}$	3.1	3.7	V
		3.5		V
$V_{GE(th)}$	$I_C = 1\text{ mA}$; $V_{GE} = V_{CE}$	4.5		6.5 V
I_{CES}	$V_{CE} = V_{CES}$; $V_{GE} = 0\text{ V}$; $T_{VJ} = 25^{\circ}\text{C}$ $T_{VJ} = 125^{\circ}\text{C}$		1.1	mA
			4.2	mA
I_{GES}	$V_{CE} = 0\text{ V}$; $V_{GE} = \pm 20\text{ V}$		180	nA
$t_{d(on)}$ t_r $t_{d(off)}$ t_f E_{on} E_{off}	Inductive load, $T_{VJ} = 125^{\circ}\text{C}$ $V_{CE} = 600\text{ V}$; $I_C = 30\text{ A}$ $V_{GE} = 15/0\text{ V}$; $R_G = 47\ \Omega$	100		ns
		70		ns
		500		ns
		70		ns
		4.6		mJ
		3.4		mJ
C_{ies}	$V_{CE} = 25\text{ V}$; $V_{GE} = 0\text{ V}$; $f = 1\text{ MHz}$	1.65		nF
R_{thJC}	(per IGBT)			0.6 K/W

Output Inverter Reverse Diodes (FRED)

Symbol	Conditions	Maximum Ratings	
I_{F25}	$T_C = 25^{\circ}\text{C}$	49	A
I_{F80}	$T_C = 80^{\circ}\text{C}$	31	A

Symbol	Conditions	Characteristic Values		
		min.	typ.	max.
V_F	$I_F = 30\text{ A}$; $T_{VJ} = 25^{\circ}\text{C}$ $T_{VJ} = 125^{\circ}\text{C}$	2.4	2.7	V
		1.77		V
I_{RM} t_{rr}	$I_F = 30\text{ A}$; $di_F/dt = 500\text{ A}/\mu\text{s}$; $T_{VJ} = 125^{\circ}\text{C}$ $V_R = 600\text{ V}$; $V_{GE} = 0\text{ V}$	27		A
		150		ns
R_{thJC}				1.3 K/W

Brake Chopper IGBT

Symbol	Conditions	Maximum Ratings	
V_{CES}	$T_{VJ} = 25^{\circ}\text{C to } 150^{\circ}\text{C}$	1200	V
V_{GES}		± 20	V
I_{C25}	$T_C = 25^{\circ}\text{C}$	30	A
I_{C80}	$T_C = 80^{\circ}\text{C}$	21	A
I_{CM} V_{CEK}	$V_{GE} = \pm 15\text{ V}; R_G = 82\ \Omega; T_{VJ} = 125^{\circ}\text{C}$ RBSOA, Clamped inductive load; $L = 100\ \mu\text{H}$	35	A
		V_{CES}	
t_{SC} (SCSOA)	$V_{CE} = V_{CES}; V_{GE} = \pm 15\text{ V}; R_G = 82\ \Omega; T_{VJ} = 125^{\circ}\text{C}$ non-repetitive	10	μs
P_{tot}	$T_C = 25^{\circ}\text{C}$	130	W

Symbol	Conditions	Characteristic Values				
		$(T_{VJ} = 25^{\circ}\text{C}, \text{ unless otherwise specified})$				
		min.	typ.	max.		
$V_{CE(sat)}$	$I_C = 25\text{ A}; V_{GE} = 15\text{ V}; T_{VJ} = 25^{\circ}\text{C}$		2.6	3.3	V	
				2.9	V	
$V_{GE(th)}$	$I_C = 0.6\text{ mA}; V_{GE} = V_{CE}$	4.5		6.5	V	
I_{CES}	$V_{CE} = V_{CES}; V_{GE} = 0\text{ V}; T_{VJ} = 25^{\circ}\text{C}$			0.9	mA	
					3.7	mA
I_{GES}	$V_{CE} = 0\text{ V}; V_{GE} = \pm 20\text{ V}$			100	nA	
$t_{d(on)}$	Inductive load, $T_{VJ} = 125^{\circ}\text{C}$ $V_{CE} = 600\text{ V}; I_C = 17.5\text{ A}$ $V_{GE} = 15/0\text{ V}; R_G = 82\ \Omega$		100		ns	
				75		ns
t_r			500		ns	
$t_{d(off)}$			70		ns	
t_f			2.7		mJ	
E_{on}			2.1		mJ	
E_{off}						
C_{ies}	$V_{CE} = 25\text{ V}; V_{GE} = 0\text{ V}; f = 1\text{ MHz}$		1		nF	
R_{thJC}	(per IGBT)				0.96	K/W

Brake Chopper Diode (FRED)

Symbol	Conditions	Maximum Ratings	
I_{F25}	$T_C = 25^{\circ}\text{C}$	26	A
I_{F80}	$T_C = 80^{\circ}\text{C}$	17	A

Symbol	Conditions	Characteristic Values				
		min.	typ.	max.		
V_F	$I_F = 17.5\text{ A}; T_{VJ} = 25^{\circ}\text{C}$		2.48	2.79	V	
				1.84	V	
I_{RM}	$I_F = 15\text{ A}; di_F/dt = 400\text{ A}/\mu\text{s}; T_{VJ} = 125^{\circ}\text{C}$ $V_R = 600\text{ V}; V_{GE} = 0\text{ V}$		16		A	
t_{tr}			130		ns	
R_{thJC}					2.3	K/W

Temperature Sensor NTC

Symbol	Conditions	Characteristic Values		
		min.	typ.	max.
R_{25}	$T = 25^{\circ}\text{C}$	4.75	5.0	5.25 k Ω
$B_{25/50}$			3375	K

Module

Symbol	Conditions	Maximum Ratings	
T_{VJ}		-40...+125	$^{\circ}\text{C}$
T_{stg}		-40...+125	$^{\circ}\text{C}$
V_{ISOL}	$I_{ISOL} \leq 1 \text{ mA}; 50/60 \text{ Hz}$	2500	V~
M_d	Mounting torque (M5)	3	Nm
		26	lb.in.
a	Max. allowable acceleration	50	m/s^2

Symbol	Conditions	Characteristic Values		
		min.	typ.	max.
d_s	Creepage distance on surface (Pin to heatsink)	11.2		mm
d_A	Strike distance in air (Pin to heatsink)	11.2		mm
Weight		86		g

Package style and outline

Dimensions in mm (1mm = 0.0394")

