

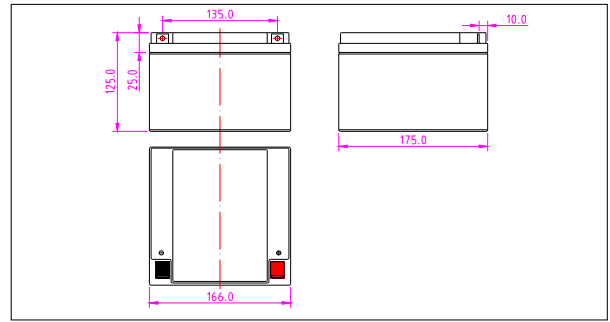

SWE12240(12V24AH)



Outer dimensions (mm)



Specifications

Nominal Voltage		12V
Rated capacity (20 hour rate)		24 Ah
Dimensions	Total Height	125 mm (4.92 inches)
	Height	125 mm (4.92 inches)
	Length	175 mm (6.90 inches)
	Width	166 mm (6.54 inches)
Weight Approx		8.0Kg (17.68 lbs)

Terminal Type (mm)

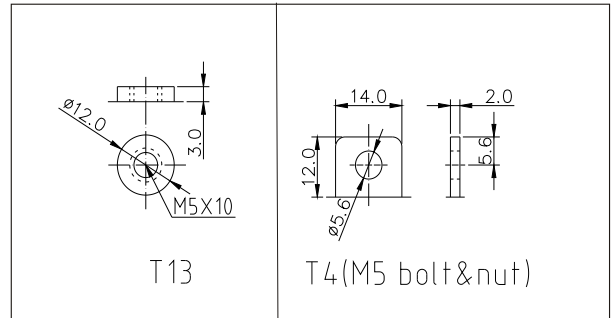

Characteristics

Capacity 25°C(77°F)	20 hour rate(1.20 A)	24.0 AH
	10 hour rate(2.20 A)	22.0AH
	5 hour rate(3.84 A)	19.2 AH
	1 hour rate(13.2 A)	13.2AH
Internal Resistance	Full charged Battery at 25°C(77°F)	11 mΩ
Capacity affected by Temperature (20hour rate)	40°C(104°F)	102%
	25°C(77°F)	100%
	0°C(32°F)	85%
	-15°C(5°F)	65%
Self-Discharge at 25°C(77°F)	Capacity after 3 month storage	91%
	Capacity after 6 month storage	82%
	Capacity after 12 month storage	64%
Terminal		T4, T13
Charge (constant Voltage)	Cycle	Initial Charging Current less than 6.0A Voltage 14.40-14.70V
	Float	Voltage 13.50-13.80V

Discharge Curves 25°C(77°F)

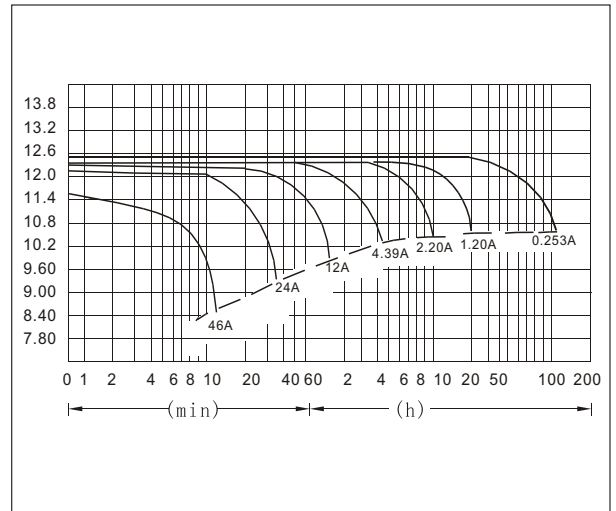

Constant Current(Amp) and Constant Power(Watt) Discharge Table at 25°C(77°F)

Time	10min	30min	1h	3h	4h	5h	8h	10h	20h	50h	100h
9.60V	A	46	25	13	5.6	4.39	3.62	2.55	2.31	1.25	0.266
	W	515	268	153	65	51	42	30	27	14.4	6.2
10.20V	A	45	24	12.4	5.5	4.28	3.56	2.50	2.25	1.21	0.259
	W	495	266	143	64	50	41	29	26	14.1	6.0
10.50V	A	43	23	12	5.4	4.22	3.51	2.48	2.20	1.20	0.253
	W	480	251	139	62	49	41	29	26	13.9	5.9
10.80V	A	40	22	12	5.2	4.15	3.43	2.42	2.14	1.19	0.250
	W	461	241	133	61	48	40	28	26	13.8	5.8
11.10V	A	37	21	11	5.1	4.03	3.34	2.35	2.09	1.13	0.242
	W	453	239	129	60	48	40	28	25	13.4	5.6