

# GNOA - GNOM

**PRV : 50 - 1000 Volts**  
**Io : 1.5 Amperes**

## FEATURES :

- \* Glass passivated chip
- \* High current capability
- \* High reliability
- \* Low reverse current
- \* Low forward voltage drop

## MECHANICAL DATA :

- \* Case : SMA Molded plastic
- \* Epoxy : UL94V-O rate flame retardant
- \* Lead : Lead Formed for Surface Mount
- \* Polarity : Color band denotes cathode end
- \* Mounting position : Any
- \* Weight : 0.067 gram

## GLASS PASSIVATED JUNCTION SILICON SURFACE MOUNT

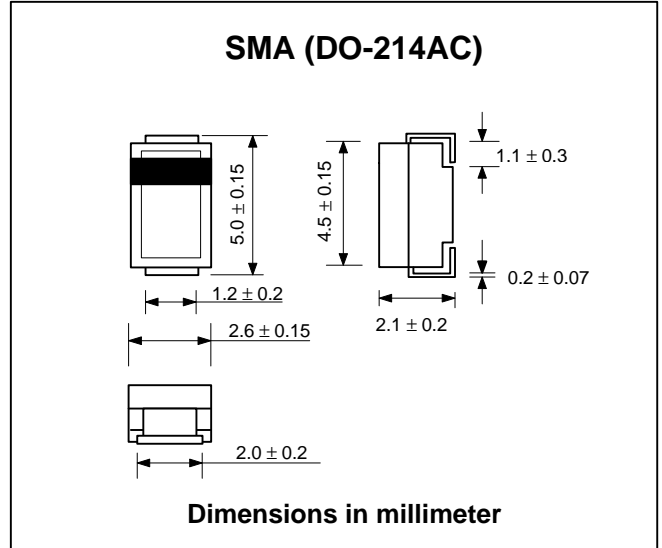

## MAXIMUM RATINGS AND ELECTRICAL CHARACTERISTICS

Rating at 25 °C ambient temperature unless otherwise specified.  
 Single phase, half wave, 60 Hz, resistive or inductive load.  
 For capacitive load, derate current by 20%.

RATING	SYMBOL	GNOA	GNOB	GNOD	GNOE	GNOG	GNOH	GNOJ	GNOK	GNOM	UNIT
Maximum Repetitive Peak Reverse Voltage	V <sub>RRM</sub>	50	100	200	300	400	500	600	800	1000	V
Maximum RMS Voltage	V <sub>RMS</sub>	35	70	140	210	280	350	420	560	700	V
Maximum DC Blocking Voltage	V <sub>DC</sub>	50	100	200	300	400	500	600	800	1000	V
Maximum Average Forward Current Ta = 75°C	I <sub>F(AV)</sub>	1.5									A
Peak Forward Surge Current 8.3ms Single half sine wave Superimposed on rated load (JEDEC Method)	I <sub>FSM</sub>	50									A
Maximum Forward Voltage at I <sub>F</sub> = 1.5 Amps.	V <sub>F</sub>	1.1									V
Maximum DC Reverse Current Ta = 25 °C at rated DC Blocking Voltage Ta = 100 °C	I <sub>R</sub>	5.0									µA
	I <sub>R(H)</sub>	50									µA
Typical Junction Capacitance (Note1)	C <sub>J</sub>	30									pF
Junction Temperature Range	T <sub>J</sub>	- 65 to + 150									°C
Storage Temperature Range	T <sub>STG</sub>	- 65 to + 150									°C

### Note :

(1) Measured at 1.0 MHz and applied reverse voltage of 4.0Vdc

## RATING AND CHARACTERISTIC CURVES ( GNOA - GNOM )

**FIG.1 - DERATING CURVE FOR OUTPUT RECTIFIED CURRENT**

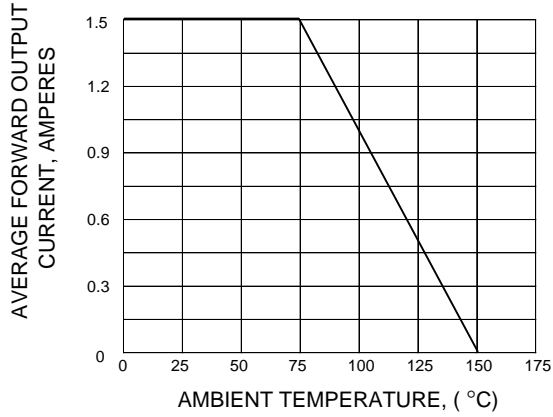

**FIG.2 - MAXIMUM NON-REPETITIVE PEAK FORWARD SURGE CURRENT**

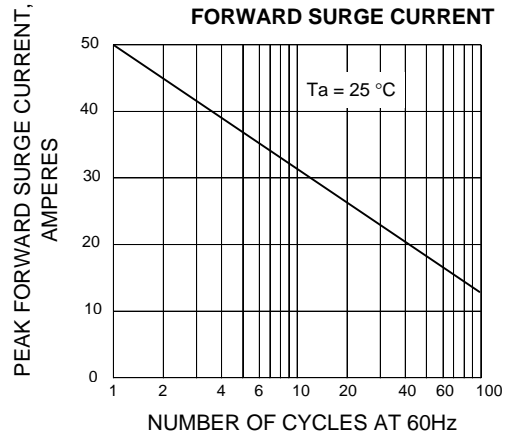

**FIG.3 - TYPICAL FORWARD CHARACTERISTICS**

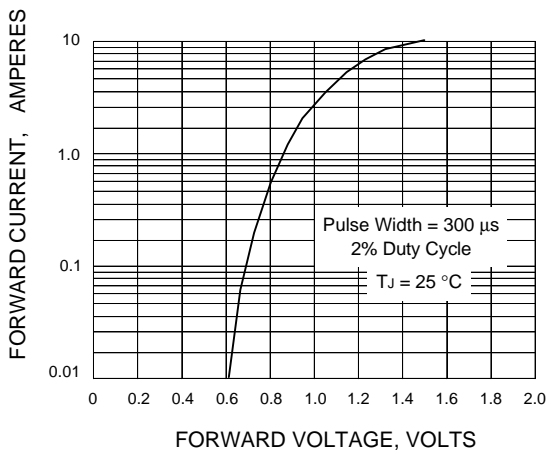

**FIG.4 - TYPICAL REVERSE CHARACTERISTICS**

