

# JBX PLUG ASSEMBLY INSTRUCTIONS

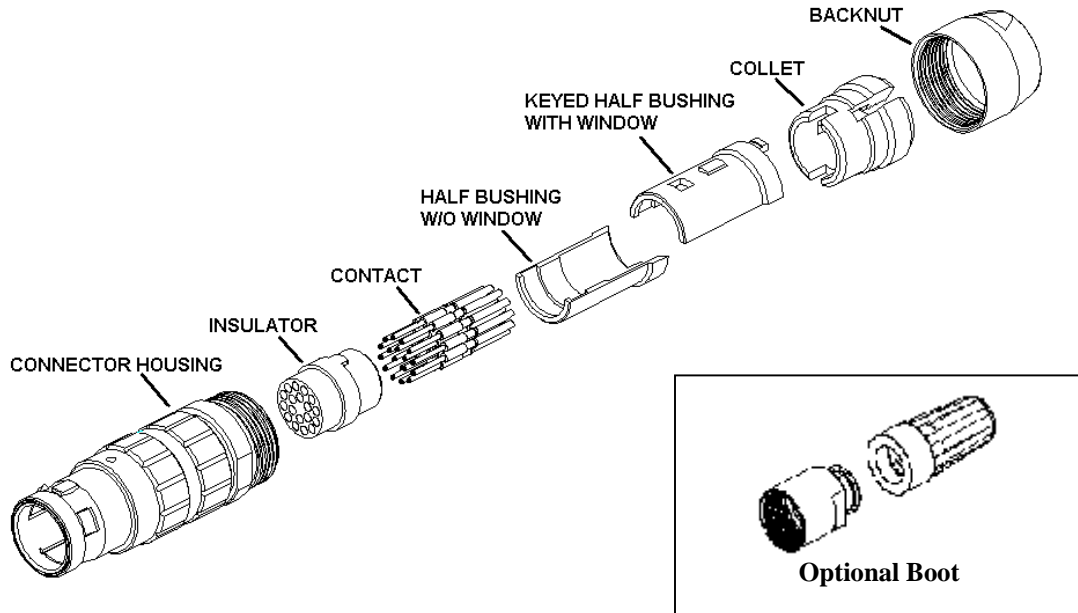

1. Determine what size cable you will be using. Then select the proper collet number for that cable.

## • Collets selection according to cable diameter

**3 or 5 collets per shell size allow a wide range of cable diameters for a single connector. Cable out diameters are for information only, since values will change with each cable construction.**

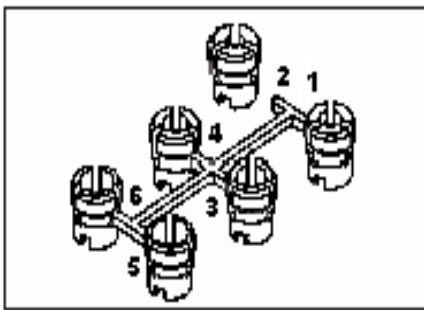

Collet number	Cable Diameter			
	Shell size 0	Size 0, option G	Shell size 1	Size 1, option G
1	1.5 - 2.5	-	2 - 2.5	-
2	2.6 - 3.5	-	2.6 - 3.5	-
3	3.6 - 4.5	-	3.6 - 4.5	6.1 - 6.7
4	-	4.6 - 5.5	4.6 - 5.5	6.8 - 7.7
5	-	5.6 - 6	5.6 - 6	7.8 - 8

**Collet number 4 in shell size 0 and collet number 6 in shellsize 1 are not used**

2. Strip the cable and each wire to the required strip length.

• Cable stripping for connectors with crimp contacts

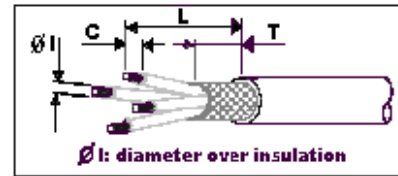

Shell size	Ø Contacts	Ø I	Stripping for FD, SR, PC			Stripping for FC			
			L	C	T	L	C	T	
0	0.7	≤1.35	15	4	7	19	4	7	
		>1.35		5.5			5.5		
0	0.9	≤1.6	15	4	7	19	4	7	
		>1.6		5.5			5.5		
1	0.7	≤1.35	16	4	8	22	4	8	
		>1.35		5.5			5.5		
	0.9	≤1.6	16	4	8	22	4	8	
>1.6		5.5		5.5					
1	1.3	≤2.1	16	4	8	22	4	8	
		>2.1		5.5			5.5		
	2.0	≤3.2	21	5.5	8	28	5.5	8	
2	0.7	≤1.35	19	4	9	28	4	9	
		>1.35		5.5			5.5		
	0.9	≤1.6	19	4	9	28	4	9	
		>1.6		5.5			5.5		
	1.3	≤2.1	19	4	9	28	4	9	
>2.1		5.5		5.5					
1.6	≤2.6	21	5.5	9	28	5.5	9		
	>2.6		7			7			
2	2.0	≤3.2	21	5.5	9	28	5.5	9	
		>3.2		7			7		
	3	0.7	≤1.35	25	4	10	35	4	10
			>1.35		7			7	
		0.9	≤1.6	25	4	10	35	4	10
>1.6	7		7						
3	1.3	≤2.1	25	4	10	35	4	10	
		>2.1		7			7		
	1.6	≤2.6	27	5.5	10	35	5.5	10	
>2.6		8.5		8.5					
3	2.0	≤3.2	27	5.5	10	35	5.5	10	
		>3.2		8.5			8.5		

• Cable stripping for connectors with solder contacts

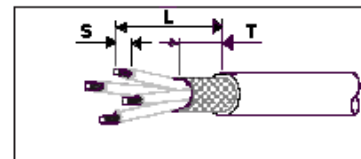

Shell size	Ø Contacts	Stripping for FD, SR, PC			Stripping for FC		
		L	S	T	L	S	T
00	0.5	9	2	4	/	/	/
0	0.5	11	2	7	16	2	7
	0.7	12	3	7	16	3	7
	0.9	12	3	7	16	3	7
1	0.5	12	2	8	19	2	8
	0.7	13	3	8	19	3	8
	0.9	13	3	8	19	3	8
	1.3	13	3.5	8	19	3.5	8
2	0.7	16	3	9	25	3	9
	0.9	16	3	9	25	3	9
	1.3	16	3.5	9	25	3.5	9
	1.6	18	4	9	25	4	9
	2.0	18	4	9	25	4	9
3	0.7	20	3	10	30	3	10
	0.9	20	3	10	30	3	10
	1.3	20	3.5	10	30	3.5	10
	1.6	22	4	10	30	4	10
	2.0	22	4	10	30	4	10

3. When assembling a plug with a protective boot (#3), prep the cable by taking the protective boot and sliding it with the small inside diameter first onto the cable. Then slide the end of the back nut (#2) that has the smaller diameter onto the cable. Next, take the collet (#1) and slide the end with the gripping teeth first onto the cable until the opposite end of the collet is flush with the cut end of the jacket. If the cable has shielding, fold back the braid so that it is covering the outside diameter of the collet. Do not place braid into any area of the alignment slots. Then insure that the braid does not interfere with the alignment slots of the collet.

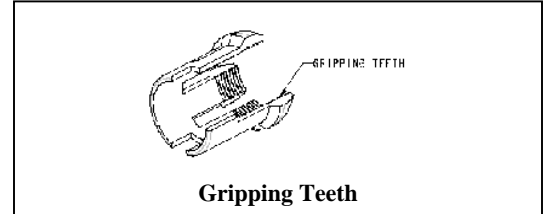
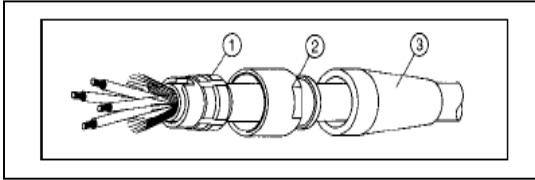

4. Attach removable contacts to wires:
  - a. If using crimped contacts, crimp the contacts onto the ends of the exposed wires using the proper crimping tool set on the correct AWG wire. (*see FIGURE 4.A*). After the contact has been crimped to the wire, check each contact to insure that the contact is securely crimped to the wire.

#### Locator for pin and socket 0.7 - 0.9 mm and 1.3 mm contacts

FIGURE 4.A



Shell size	Ø contacts	AWG	Male contact			Female contact		
			SOURIAU P/N	DANIELS P/N	ASTRO P/N	SOURIAU P/N	DANIELS P/N	ASTRO P/N
0	0.7	22 - 24 - 26	JBX 0 OUT LP07	86 - 223	/	JBX 0 OUT LS07	86 - 224	/
	0.9	20 - 22 - 24	JBX 0 OUT LP09	86 - 225	/	JBX 0 OUT LS09	86 - 226	/
1	0.7	22 - 24 - 26	JBX 1 OUT LP07	86 - 196	642 - 001	JBX 1 OUT LS07	86 - 197	642 - 004
	0.9	20 - 22 - 24	JBX 1 OUT LP09	86 - 198	642 - 002	JBX 1 OUT LS09	86 - 199	642 - 005
	1.3	18 - 20 - 22	JBX 1 OUT LP13	86 - 200	642 - 003	JBX 1 OUT LS13	86 - 201	642 - 006
2	0.7	22 - 24 - 26	JBX 2 OUT LP07	86 - 202	642 - 007	JBX 2 OUT LS07	86 - 203	642 - 010
	0.9	20 - 22 - 24	JBX 2 OUT LP09	86 - 204	642 - 008	JBX 2 OUT LS09	86 - 205	642 - 011
	1.3	18 - 20 - 22	JBX 2 OUT LP13	86 - 206	642 - 009	JBX 2 OUT LS13	86 - 207	642 - 012
3	0.7	22 - 24 - 26	JBX 3 OUT LP07	86 - 217	642 - 014	JBX 3 OUT LS07	86 - 214	642 - 017
	0.9	20 - 22 - 24	JBX 3 OUT LP09	86 - 218	642 - 015	JBX 3 OUT LS09	86 - 215	642 - 018
	1.3	18 - 20 - 22	JBX 3 OUT LP13	86 - 219	642 - 016	JBX 3 OUT LS13	86 - 216	642 - 019

#### Turret with locator for pin and socket 1.6 mm and 2 mm contacts



Shell size	Ø contacts	AWG	Male and female contacts		
			SOURIAU P/N	DANIELS P/N	ASTRO P/N
2	1.6	14 - 16 - 18	JBX 2 OUT LT16	TH 564	650 - 030
	2	12 - 14 - 16	JBX 2 OUT LT20	TH 565	650 - 031
3	1.6	14 - 16 - 18	JBX 3 OUT LT16	TH 566	650 - 038
	2	12 - 14 - 16	JBX 3 OUT LT20	TH 567	650 - 035

## Crimping Tool

Specifications MIL-C-22520 / 7.01		
	MIL P/N – SOURIAU P/N	Supplier P/N
	Contacts 0.7 mm – 0.9 mm and 1.3mm	MIL-22520/7-01 Daniels: MH860
Specifications MIL-C-22520 / 1.01		
	MIL P/N – SOURIAU P/N	Supplier P/N
	Contacts 1.6 mm and 2 mm	MIL-22520/1-01 Daniels: AF8 Buchanan: 615708

- b. If using soldered contacts, prep each wire with flux and then tin dip each exposed wire end. Next pre-load a piece of heat shrink onto the wire (Individual heat shrink tubes are optional). Solder each wire to the solder cup end of the contact. To avoid shorts, make sure that no solder comes in contact with any other contact or wire on the connector. After the contact has been soldered to the wire, check each contact to insure that the contact is securely soldered to the wire. Slide the pre-loaded heat shrink over the solder joint and shrink into place. Do not over-heat the solder joint area as it can cause the solder to re-flow or it could burn the wire insulation.

### 5. If inserting removable contacts:

- a. Starting with the interface end of the contact, carefully insert each contact into the backside of the insulator that has the position loading path indicator (worm) on it. Start with the end of the position loading path indicator (worm) that has the half circle on it (Position #1). Then follow the position loading path indicator (worm) around the insulator. You will go counter clockwise if using a male contact and clockwise if using a female contact (see diagram below for the position loading path indicator (worm) layout). If the connector has center contacts, it is sometimes easier to start at the end of the position loading path indicator (worm) (last position) and work backwards. This is up to the assembler and the process they are using to insert the contacts. Make sure not to bend the contact when inserting it into the insulator. It is extremely important that the contact is completely seated in to the insulator. For the connector to function properly, the contact should click/snap into place when seated. To confirm the seating of the contact, check each contact for proper seating.

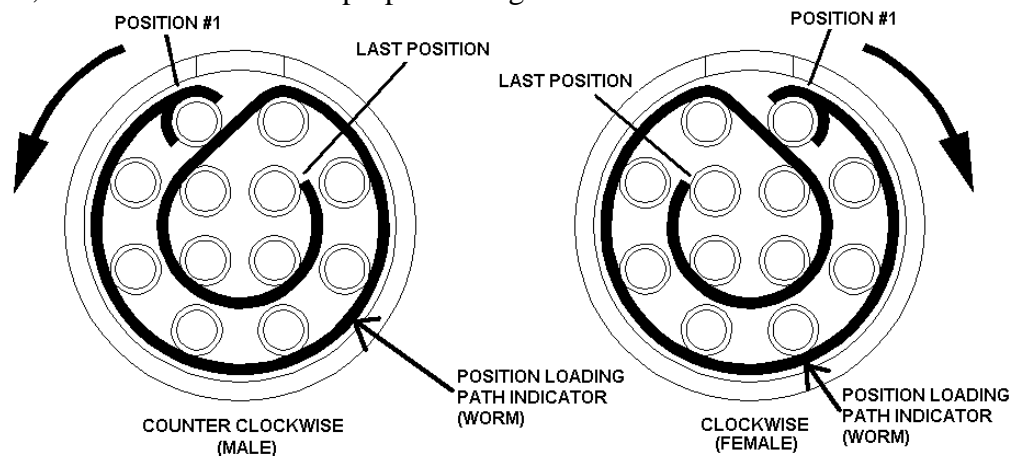

6. Removal of contacts:
  - a. Using the proper extraction tool insert the tool over the front of the contact and push contact out. Failure to use the proper extraction tool can result in damage to the contact.

## TOOLINGS – JBX – JKX

### Manual Extraction Tools

Contacts automatically extracted without pulling on the cable.

The extraction tool is the same for both male and female contacts.

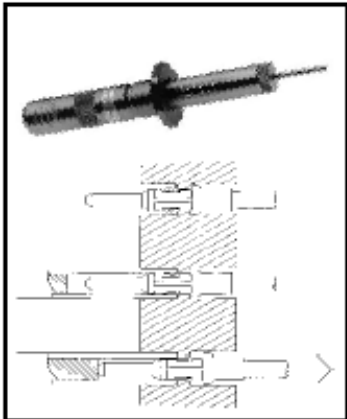

Shell size	∅ Contacts	SOURIAU Part number	ASTRO Part number
0	0.7	JBX OUT DC 07	ATJP 2045
	0.9	JBX OUT DC 09	ATJP 2057
1	0.7	JBX OUT DC 07	ATJP2045
	0.9	JBX OUT DC 09	ATJP 2057
	1.3	JBX OUT DC 13	ATJP 2077
2	0.7	JBX OUT DC 07	ATJP 2045
	0.9	JBX OUT DC 09	ATJP 2057
	1.3	JBX OUT DC 13	ATJP 2077
	1.6	JBX OUT DC 16	ATJP 2095
	2.0	JBX OUT DC 20	ATJP 2115
3	0.7	JBX OUT DC 07	ATJP 2045
	0.9	JBX OUT DC 09	ATJP 2057
	1.3	JBX OUT DC 13	ATJP 2077
	1.6	JBX OUT DC 16	ATJP 2095
	2.0	JBX OUT DC 20	ATJP 2115

7. Take the keyed half bushing (#6) and place it over the insulator so that the window is lined up with the key on the insulator and the key on the half bushing is pointing to the back of the insulator (position loading path indicator (worm end)). Then take the half bushing without the window (#6) and place on the opposite side of the insulator so that both half bushings are aligned with each other.
8. Take the collet that is pre-loaded on the cable and align the slots in the collet with the keys on the end of the half bushings (you may need to move the braid away from the slots and spin the collet slightly). Once they are aligned, compress the assembly so that it is in line and there are no gaps between the collet & the half bushings. The braid should still be in place once the assembly is inserted.
9. Take a connector housing (#7) and slide it over the insulator so that the red dot on the connector housing lines up with the key on the half bushing with window. Push the whole assembly into the connector housing until it bottoms out. Insure that the keys are seated properly by turning the collet that is already aligned with the half bushings. If the collet does not turn, then the keys are correctly aligned. If the collet does turn, then you must withdraw the assembly & realign the keys.

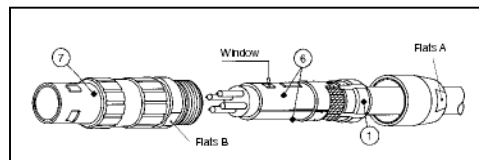

10. Once the assembly is installed into the connector housing and is aligned properly, apply thread lock to thread area. Then slide the back nut up until you can manually start the back nut threads onto the threaded end of the connector housing. Tighten the back nut up as far as you can by hand, then take the appropriate wrenches and place the wrenches onto the flats located on the connector housing. Do not over torque back nut as it can cause connector failure.

11. If the connector requires a protective boot, slide the boot over the lip on the back nut.

12. Potting of backend of plug with clipped contacts:

Clipped contacts are designed to float in the connector so that they self align when mated. It is sometimes necessary to pot the back end of the connector so that the contacts are sealed off from the environment. When this application is needed, it is recommended that the assembler engage a mating connector/alignment tool to the assembly being potted. Once the mating connector/alignment tool is engaged, it must be left engaged until the potting compound has hardened. This will insure that the true position requirements are met. If the application is for low volume, a mating connector can be used. If the application is for high volume, it is recommended that an alignment tool be purchased from the supplier.

### **Trouble Shooting**

<b>Problem:</b>	<b>Cause:</b>	<b>Correction:</b>
Contact will not seat in connector, contact backing out.	Wrong wire or insulation size, wrong strip length, poor crimping, broken clips, damaged insulator, removed contact without proper removal tool, bad crimp.	Use correct wire, adjust strip length, strip and re-crimp with new contact, replace insulator, using wrong crimp tool, replace contact.
Bent solder contact	Bent in handling, bent in soldering operation, connector assembled incorrectly.	Replace insert with contacts.
	Pins and insulator were inserted into electrical test while unprotected by shell	
Connector will not release from mating part or operate correctly	Not using flats on latching sleeve and back nut to torque connector, improper assembly of the connector, over mold material inside connector.	Release back nut and re-torque, disassemble and reassemble, replace connector.
Over tightened the back nut.	Connector will not release from mating part or operate correctly, damage connector.	Loosen back nut and retighten.
Collet will not grip cable.	Loose cable in connector.	Check correct collet size is being used.
Connector will not assemble.	Incorrect alignment of key in connector, half bushings, connector housing, insulator, collet, braid in key slots in collet.	Disassemble connector and reassemble connector-aligning keys, relocate braid in collet.
Contact stubbing after mating.	Bent contact and damaged contact, connector-assembled incorrectly.	Re-align contact, replace insert with contacts.
Electrical failure.	Improper crimping, wrong wire strip length, wire loading incorrect location, poor solder joint.	Remove contact with correct removal tool, reinstall new contact, and verify strip length.