



SEMICONDUCTOR

SF201 THRU SF206

SUPER FAST RECTIFIER
Reverse Voltage: 50 to 400 Volts
Forward Current: 2.0 Amperes

SILICON RECTIFIER

FEATURES

- Low forward voltage drop
- High current capability
- High reliability
- High surge current capability
- Super fast recovery time
- Good for use in switching mode circuits
- Plastic package has Underwriters Laboratory Flammability Classification 94V-0

MECHANICAL DATA

- Case: JEDEC DO-15 molded plastic body
- Terminals: Plated axial leads, solderable per MIL-STD-750, method 2026
- Polarity: Color band denotes cathode end
- Mounting Position: Any
- Weight: 0.014 ounce, 0.40 gram

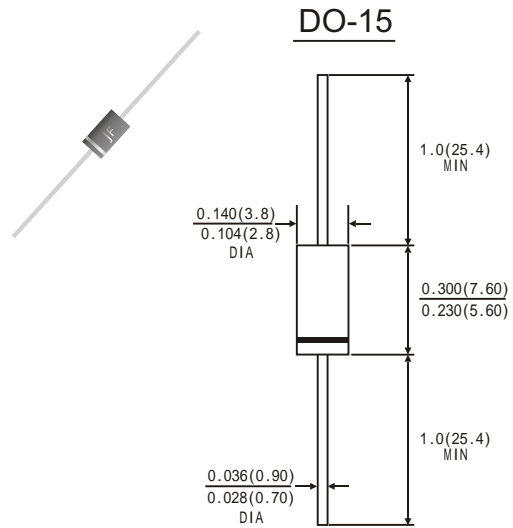

Dimensions in inches and (millimeters)

MAXIMUM RATINGS AND ELECTRICAL CHARACTERISTICS

(Rating at 25 °C ambient temperature unless otherwise specified, Single phase, half wave, 60Hz, resistive or inductive load. For capacitive load, derate current by 20%.)

	Symbols	SF 201	SF 202	SF 203	SF 204	SF 205	SF 206	Units
Maximum Recurrent Peak Reverse Voltage	V _{RRM}	50	100	150	200	300	400	Volts
Maximum RMS Voltage	V _{RMS}	35	70	105	140	210	280	Volts
Maximum DC Blocking Voltage	V _{DC}	50	100	150	200	300	400	Volts
Maximum Average Forward Rectified Current 0.375"(9.5mm)lead length at T _A =55 C °	I _(AV)	2.0						Amps
Peak Forward Surge Current 8.3ms single half sine-wave superimposed on rated load (JEDEC method)	I _{FSM}	50.0						Amps
Maximum Instantaneous Forward Voltage at 2.0 A	V _F	0.95				1.25		Volts
Maximum DC Reverse Current at rated DC Blocking Voltage	T _A =25°C	5.0						μA
	T _A =100°C	50						
Maximum reverse recovery time(Note1)	T _{rr}	35						ns
Typical Junction Capacitance(note2)	C _J	60					30	Pf
Operating Junction And Storage Temperature Range	T _J	-65 to +125						°C
	T _{STG}	-65 to +150						

Note: 1. Test conditions: I_F=0.5A, I_R=1.0A, I_{RR}=0.25A.

2. Measured at 1MHz and applied reverse voltage of 4.0 Volts.

RATINGS AND CHARACTERISTIC CURVES SF201 THRU SF206

FIG.1-TEST CIRCUIT DIAGRAM AND REVERSE RECOVERY TIME CHARACTERISTIC

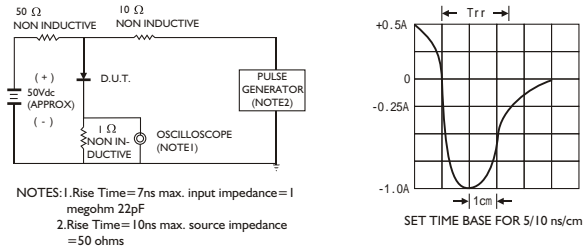

FIG.2-TYPICAL FORWARD CURRENT DERATING CURVE

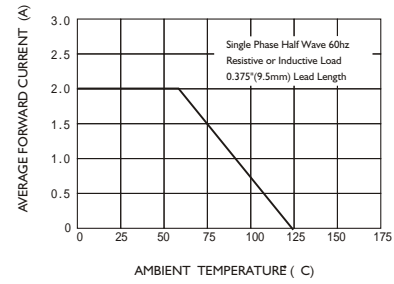

FIG.3-TYPICAL INSTANTANEOUS FORWARD CHARACTERISTICS

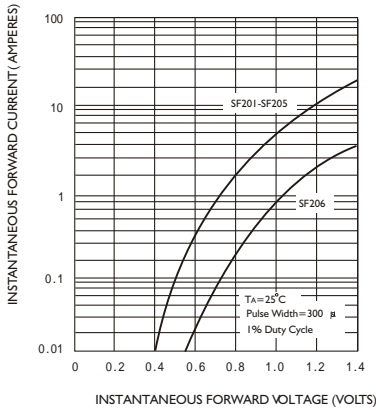

FIG.4-TYPICAL REVERSE CHARACTERISTICS

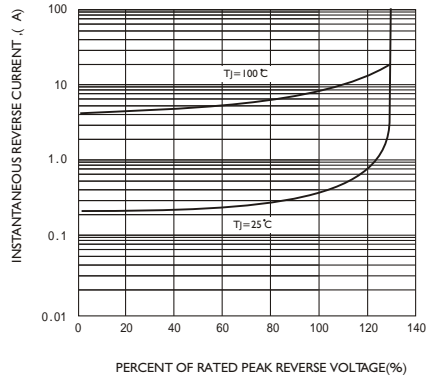

FIG.5-MAXIMUM NON-REPETITIVE FORWARD SURGE CURRENT

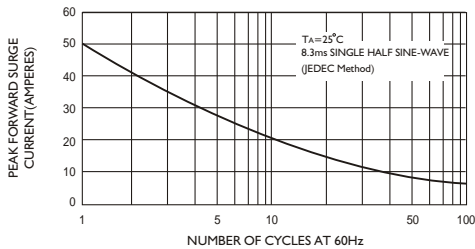

FIG.6-TYPICAL JUNCTION CAPACITANCE

