

Description

The ACE707A are Pulse Frequency Modulation (PFM) DC/DC converters. These two devices are functionally equivalent except the switching current limit. The ACE707A is for lower power systems with 100mA current limit.

The ACE707A feature a wide input voltage. The operation voltage is ranged from 1V to 12V. A current limited, fixed off-time control scheme conserves operating current, resulting in high efficiency over a broad range of load current. They also feature low quiescent current, switching current limiting, low temperature coefficient, etc.

Fewer tiny external components are required in the applications to save space and lower cost. Furthermore, to ease its use in different systems, a disable terminal is designed to turn on or turn off the chip.

The ACE707A are available in SOT-23-5 package.

Features

- Low Quiescent Current In Active Mode (Not Switching): 17 μ A Typical ,In Shutdown Mode: < 1 μ A
- Low Operating V_{IN} 1.0V Typical for ACE707A
- Low V_{CESAT} Switch 70mV Typical at 70mA for ACE707A
- High Output Voltage: up to 34V
- Fixed Off-Time Control
- Switching Current Limiting 100mA Typical for ACE707A
- Operating Temperature Range: -40 $^{\circ}$ C to 85 $^{\circ}$ C

Application

- MP3, MP4
- Battery Power Supply System
- LCD/OLED Bias Supply
- Handheld Device
- Portable Communication Device

Absolute Maximum Ratings

Parameter	Symbol	Max	Unit
Input voltage	V_{IN}	15	V
SW Voltage	V_{SW}	36	V
FB Voltage	V_{FB}	V_{IN}	V
$\overline{\text{SHDN}}$ Pin Voltage	$V_{\overline{\text{SHDN}}}$	15	V
Thermal Resistance (Junction to Ambient, no Heat sink)	$R_{\theta JA}$	265	$^{\circ}\text{C}/\text{W}$
Operating Junction Temperature	T_J	150	$^{\circ}\text{C}$
Storage Temperature Range	T_{SG}	-65 TO 150	$^{\circ}\text{C}$
Lead Temperature (Soldering, 10sec)	T_{LEAD}	260	$^{\circ}\text{C}$
ESD (Human Body Model)		3000	V

Note 1: Stresses greater than those listed under "Absolute Maximum Ratings" may cause permanent damage to the device. These are stress ratings only, and functional operation of the device at these or any other conditions beyond those indicated under "Recommended Operating Conditions" is not implied. Exposure to "Absolute Maximum Ratings" for extended periods may affect device reliability.

Packaging Type

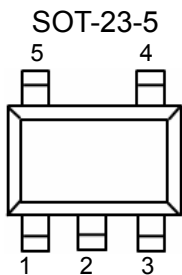

Pin	SOT-23-5	Function
SW	1	Switch Pin. This is the collector of the internal NPN power switch. Minimize the trace area connected to this Pin to minimize EMI
GND	2	Ground Pin. GND should be tied directly to ground plane for best performance
FB	3	Feedback Pin. Set the output voltage through this pin. The formula is $V_{OUT}=1.23V*(1+R1/R2)$. Keep the loop between Vout and FB as short as possible to minimize the ripple and noise, which is beneficial to the stability and output ripple
$\overline{\text{SHDN}}$	4	Shutdown Control Pin. Tie this pin above 0.9V to enable the device. Tie below 0.25V to turn off the device
V_{IN}	5	Supply Input Pin. Bypass this pin with a capacitor as close to the device as possible

Ordering Information

Selection Guide

ACE707A XX + H

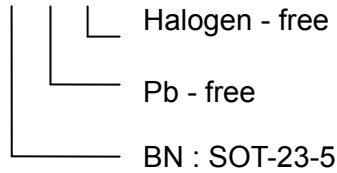

Functional Block Diagram

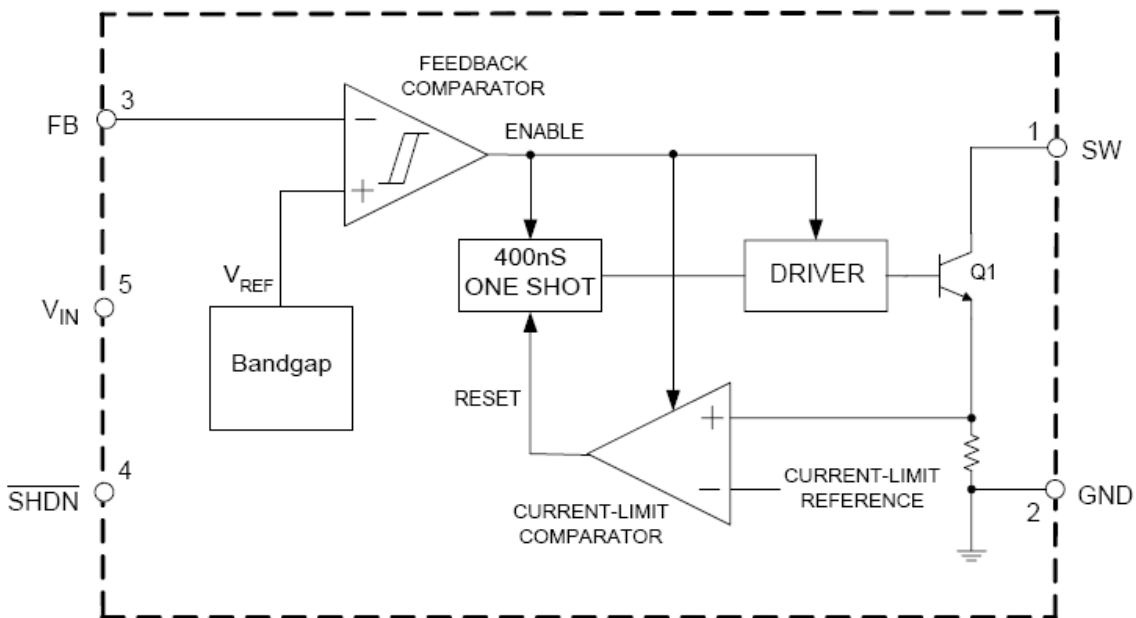

Recommended Work Conditions

Item	Symbol	Min	Max	Unit
Input voltage	V _{IN}	1.0	12ut	V
Operating Temperature	T _A	-40	85	°C

Electrical Characteristics

$V_{IN}=V_{SHDN}=1.2V$, $T_A=25^{\circ}C$, unless otherwise specified.

Parameter	Symbol	Test Conditions	Min	Typ	Max	Unit
Input Voltage	V_{IN}		1.0		12	V
Quiescent Current	I_Q	Not Switching		17	30	μA
		$V_{SHDN}=0V$			1	
Feedback Voltage	V_{FB}		1.205	1.23	1.255	V
FB Comparator Hysteresis	V_{FBH}			8		mV
FB Pin Bias Current	I_{FB}	$V_{FB}=1.23V$		30	80	nA
Output Voltage Line Regulation	L_{NR}	$1.2V < V_{IN} < 12V$		0.05	0.1	%/V
Switching Current Limit	I_L		75	100	125	mA
Switch Saturation Voltage	V_{CESAT}	$I_{SW}=70mA$		70	120	mV
Switch Off Time	T_{OFF}	$V_{FB} > 1V$		400		nS
		$V_{FB} < 0.6V$		1.5		μS
SHDN Input Threshold High	V_{TH}		0.9			V
SHDN Input Threshold Low	V_{TL}				0.25	
SHDN Pin Current	I_{SHDN}	$V_{SHDN}=1.2V$		2	3	μA
		$V_{SHDN}=5V$		8	12	
Switch Leakage Current	I_{SWL}	Switch Off, $V_{SW}=5V$		0.01	5	μA

Typical Performance Characteristics

Unless otherwise note, $V_{IN}=1.2V$

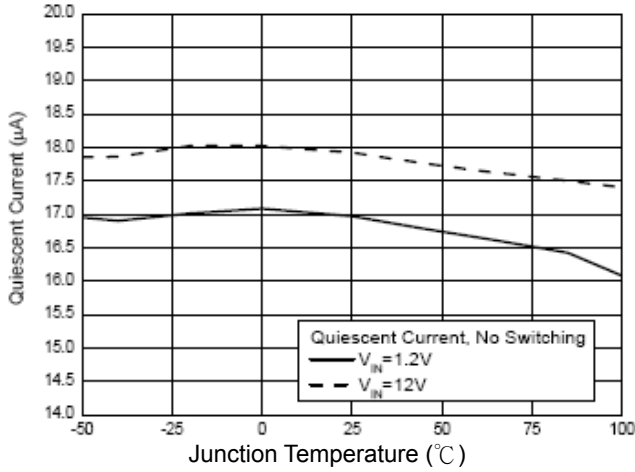

Figure 1. Quiescent Current vs. Junction Temperature

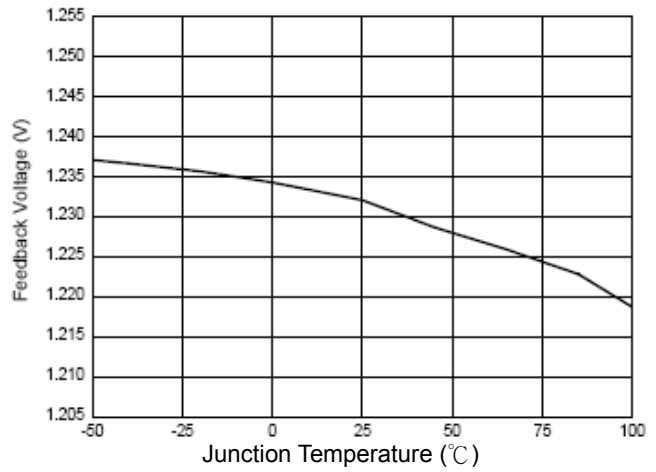

Figure 2. Feedback Voltage vs. Junction Temperature

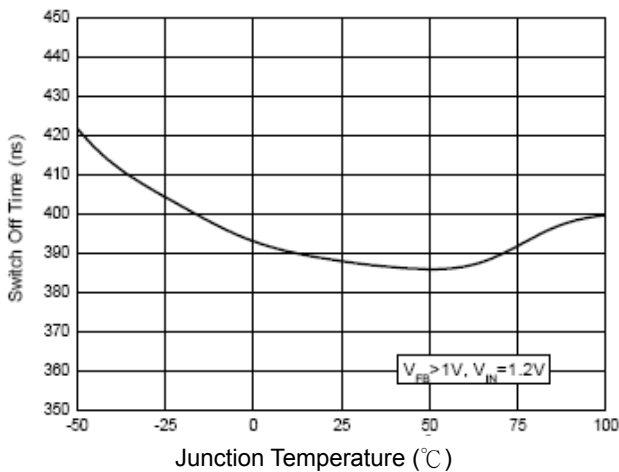

Figure 3. Switch Off Time vs. Junction Temperature

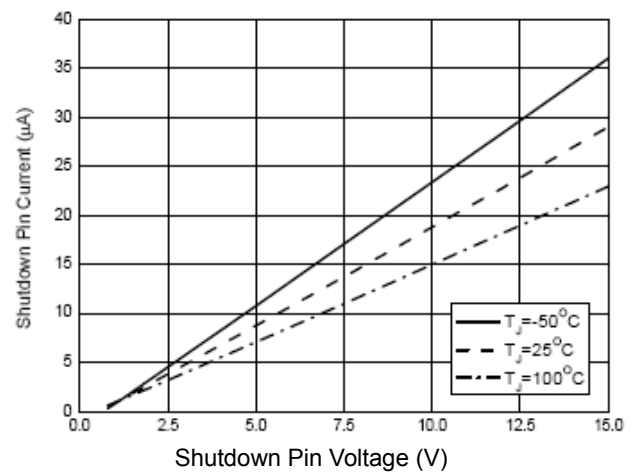

Figure 4. Shutdown Pin Current vs. Shutdown Pin Voltage

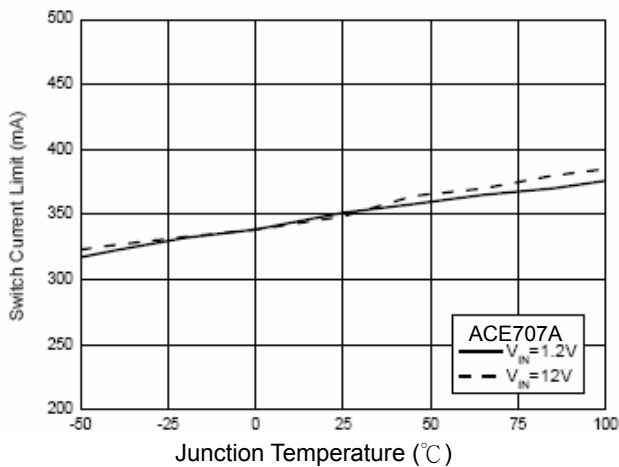

Figure 5. Switch Current Limit vs. Junction Temperature

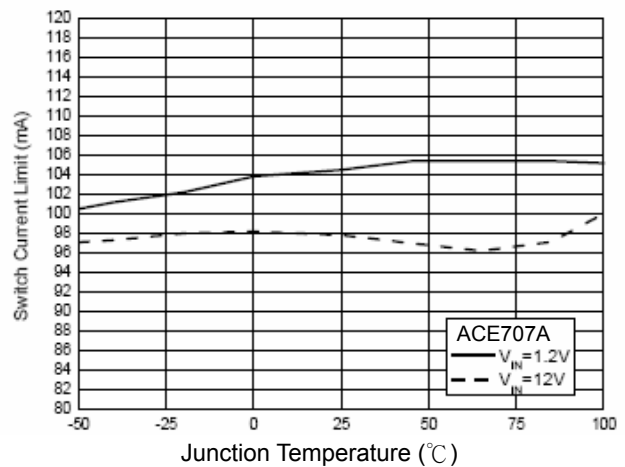

Figure 6. Switch Current Limit vs. Junction Temperature

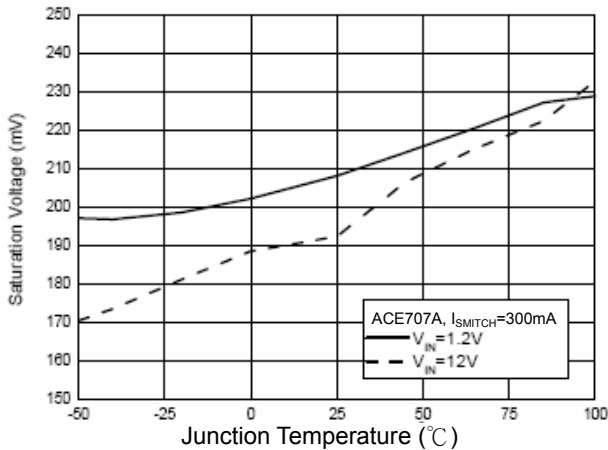

Figure 7. Saturation Voltage vs. Junction Temperature

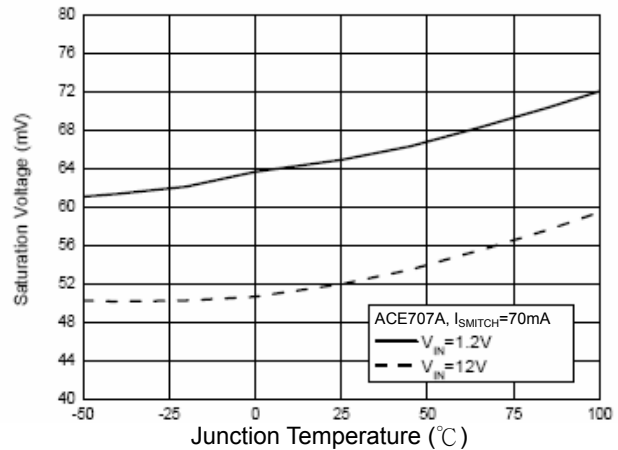

Figure 8. Saturation Voltage vs. Junction Temperature

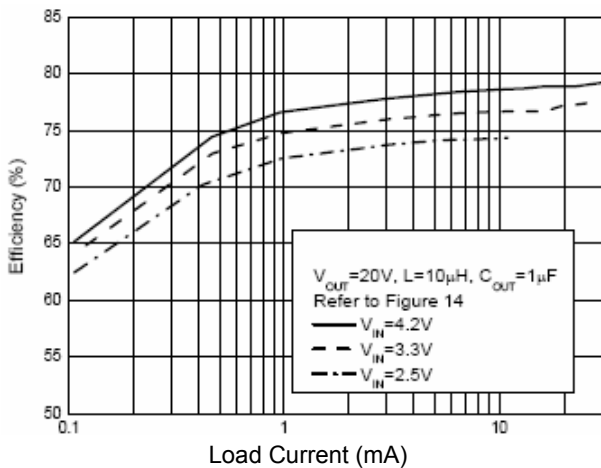

Figure 9. Efficiency

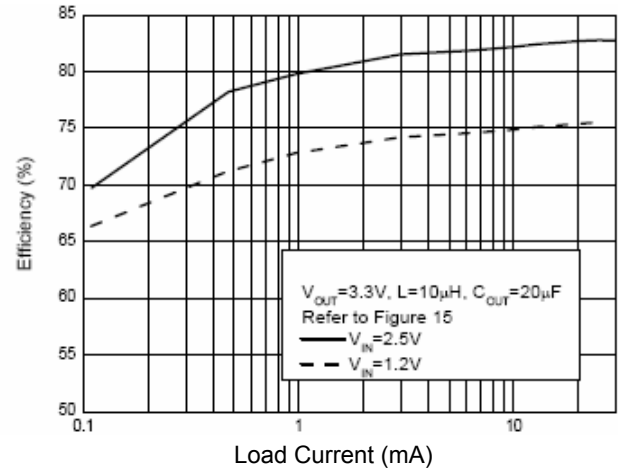

Figure 10. Efficiency

Application Information

Operating Principles

ACE707A feature a constant off-time control scheme. Refer to Figure 3, the bandgap voltage V_{REF} (1.23V typical) is used to control the output voltage.

When the voltage at the FB pin drops below the lower hysteresis point of Feedback Comparator (typical hysteresis is 8mV), the Feedback Comparator enables the chip and the NPN power switch is turned on, the current in the inductor begins to ramp up and store energy in the coil while the load current is supplied by the output capacitor. Once the current in the inductor reaches the current limit, the Current-Limit Comparator resets the 400ns One-Shot which turns off the NPN switch for 400ns. The SW voltage rises to the output voltage plus a diode drop and the inductor current begins to ramp down. During this time the energy stored in the inductor is transferred to C_{OUT} and the load. After the 400ns off-time, the NPN switch is turned on and energy will be stored in the inductor again.

This cycle will continue until the voltage at FB pin reaches 1.23V, the Feedback Comparator disables the chip and turns off the NPN switch. The load current is then supplied solely by output capacitor and the output voltage will decrease. When the FB pin voltage drops below the lower hysteresis point of Feedback Comparator, the Feedback Comparator enables the device and repeats the cycle described previously. Under not switching condition, the I_Q of the device is about 17μA.

The ACE707A contains additional circuitry to provide protection during start-up or under short-circuit conditions. When the FB pin voltage is lower than approximately 0.6V, the switch off-time is increased to 1.5 μ s and the current limit is reduced to about 250mA (70mA for ACE707A). This reduces the average inductor current and helps to minimize the power dissipation in the ACE707A power switch, in the external inductor and in the diode.

The SHDN pin can be used to turn off the ACE707A and reduce the IQ to less than 1 μ A. In shutdown mode the output voltage will be a diode drop below the input voltage.

Typical Application

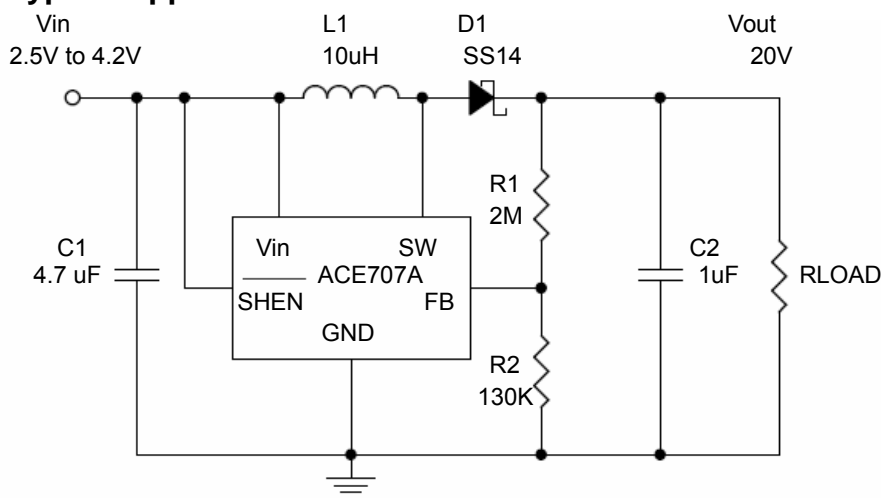

C1, C2: X5R or X7R Ceramic Capacitor
L1: SUMIDA CDRH4D16FB/NP-100MC or Equivalent

Figure 11. ACE707A Typical Application in LCD/OLED Bias Supply

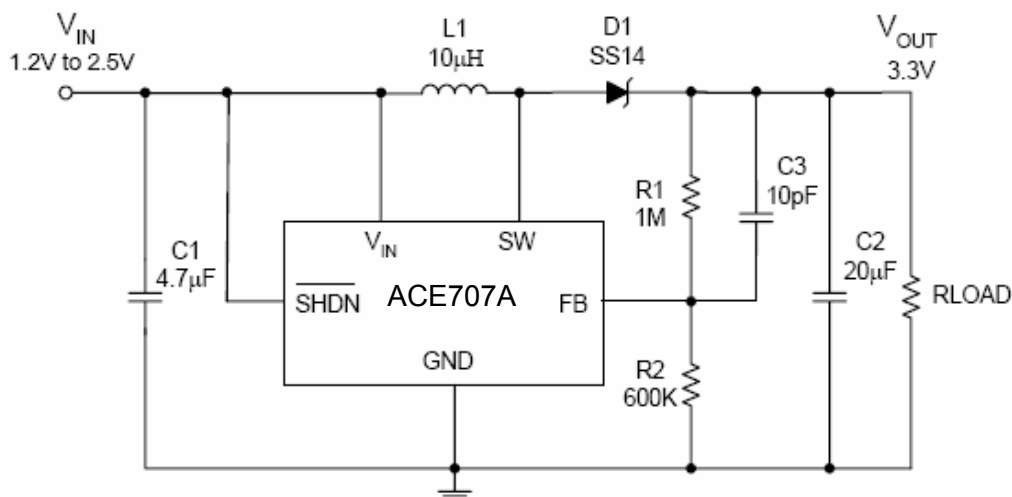

C1, C2, C3: X5R or X7R Ceramic Capacitor
L1: SUMIDA CDRH4D16FB/NP-100MC or Equivalent

Figure 12. ACE707A Typical Application in 1 or 2 Cells to 3.3V Boost Converter

Packing Information

SOT-23-5

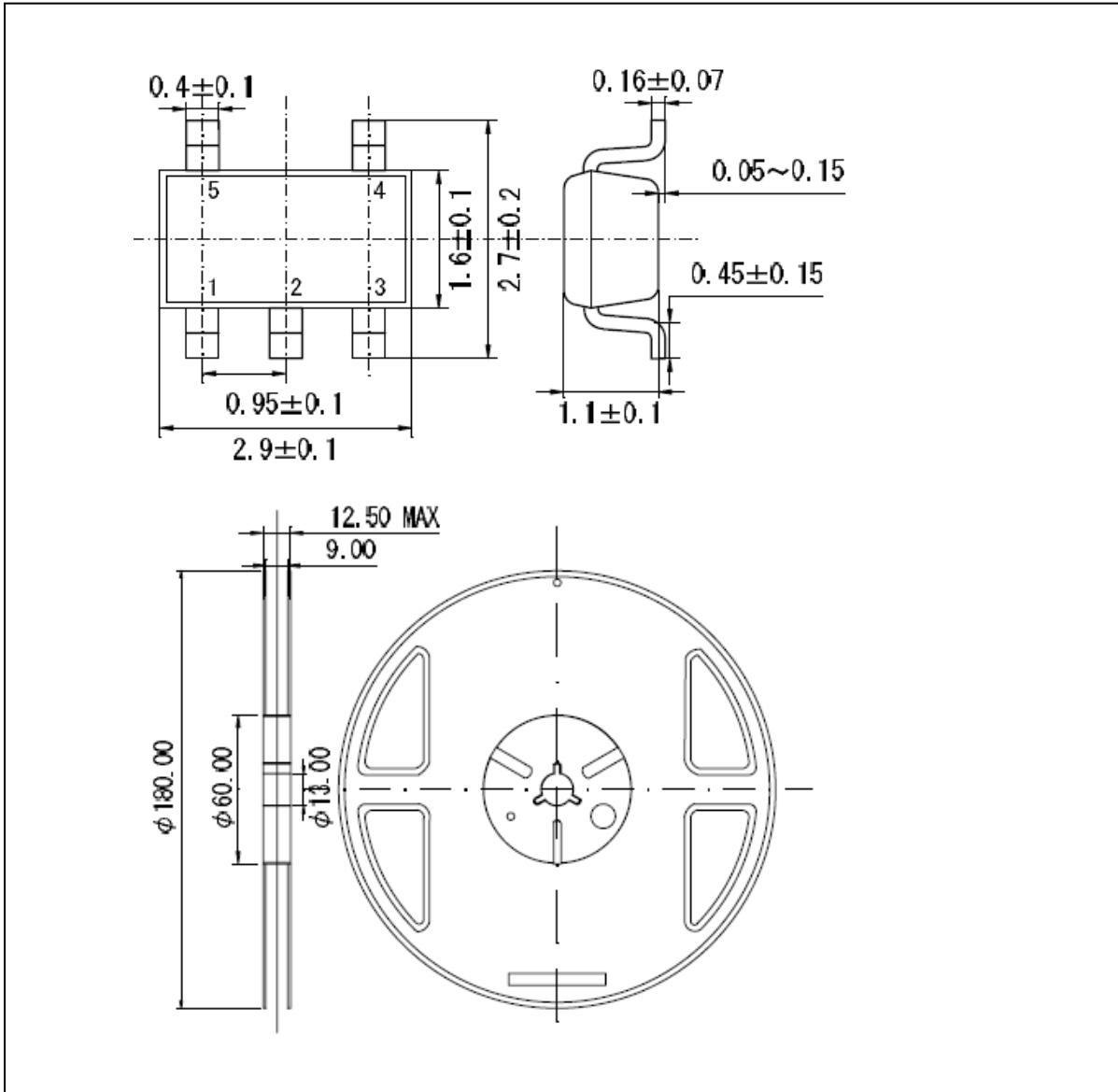

Notes

ACE does not assume any responsibility for use as critical components in life support devices or systems without the express written approval of the president and general counsel of ACE Electronics Co., LTD. As sued herein:

1. Life support devices or systems are devices or systems which, (a) are intended for surgical implant into the body, or (b) support or sustain life, and whose failure to perform when properly used in accordance with instructions for use provided in the labeling, can be reasonably expected to result in a significant injury to the user.
2. A critical component is any component of a life support device or system whose failure to perform can be reasonably expected to cause the failure of the life support device or system, or to affect its safety or effectiveness.