



# TAI-SAW TECHNOLOGY CO., LTD.

No. 3, Industrial 2nd Rd., Ping-Chen Industrial District,  
Taoyuan, 324, Taiwan, R.O.C.

TEL: 886-3-4690038 FAX: 886-3-4697532  
E-mail: [tstsales@mail.taisaw.com](mailto:tstsales@mail.taisaw.com) Web: [www.taisaw.com](http://www.taisaw.com)

## Approval Sheet For Product Specification

Issued Date:

Product Name: SAW Filter 433.92MHz SMD5X5mm

TST Parts No.: TA0264A

Customer Parts No.: \_\_\_\_\_

Company: _____
Division: _____
Approved by : _____
Date: _____

Checked by: Jacky Huang

Approval by: Francis Chen

Date: 2003/10/15



# TAI-SAW TECHNOLOGY CO., LTD.

No. 3, Industrial 2nd Rd., Ping-Chen Industrial District,  
Taoyuan, 324, Taiwan, R.O.C.

TEL: 886-3-4690038 FAX: 886-3-4697532

E-mail: [tstsales@mail.taisaw.com](mailto:tstsales@mail.taisaw.com) Web: [www.taisaw.com](http://www.taisaw.com)

## SAW Filter 433.92 MHz

MODEL NO.: TA0264A

REV. NO.:3

### A. MAXIMUM RATING:

1. Input Power Level: 10 dBm
2. DC voltage: 0 V
3. Operating Temperature: -45°C to +120°C
4. Storage Temperature: -45°C to +120°C

RoHS Compliant  
Lead free  
Lead-free soldering

### B. ELECTRICAL CHARACTERISTICS:

Reference temperature: TA = -40 to 95°C

Item	Min.	Typ.	Max.	Note
Center frequency $F_c$ (MHz)	-	433.92	-	1
Minimum I.L. (433.8~434.12 MHz) (dB) $IL_{min}$	-	2.2	4.0	
Pass band (relative to $IL_{min}$ )				
433.76~434.08 MHz (dB)	-	-	2.0	1
433.74~434.10 MHz (dB)	-	-	3.0	
433.68~434.16 MHz (dB)	-	-	6.0	
Pass bandwidth (relative to $IL_{min}$ ) $BW_3$ (KHz)	670	720	-	
Attenuation:( relative to $IL_{min}$ ) (dB)				
10~414 MHz (dB)	45	48	-	1
414~427.5 MHz (dB)	40	43	-	
427.5~432.84 MHz (dB)	15	19	-	
434.92~442 MHz (dB)	10	14	-	
442~550 MHz (dB)	35	38	-	
550~1000 MHz (dB)	45	50	-	
Impedance at $F_c$ ; Input $Z_{IN}=R_{IN}/C_{IN}$ Output $Z_{OUT}=R_{OUT}/C_{OUT}$	227Ω // 3.3 pF 227Ω // 3.3 pF			
Turnover To (deg.C)	25 typ.			

Note1. The standard definitions is in JIS C 6703

### C. FREQUENCY CHARACTERISTICS:

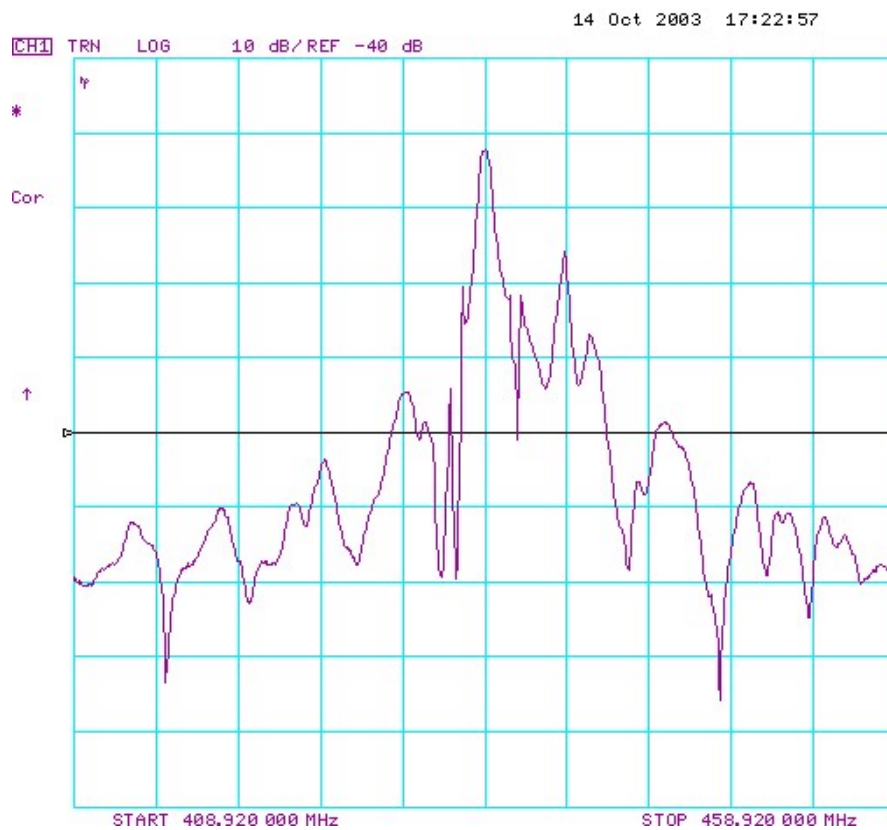
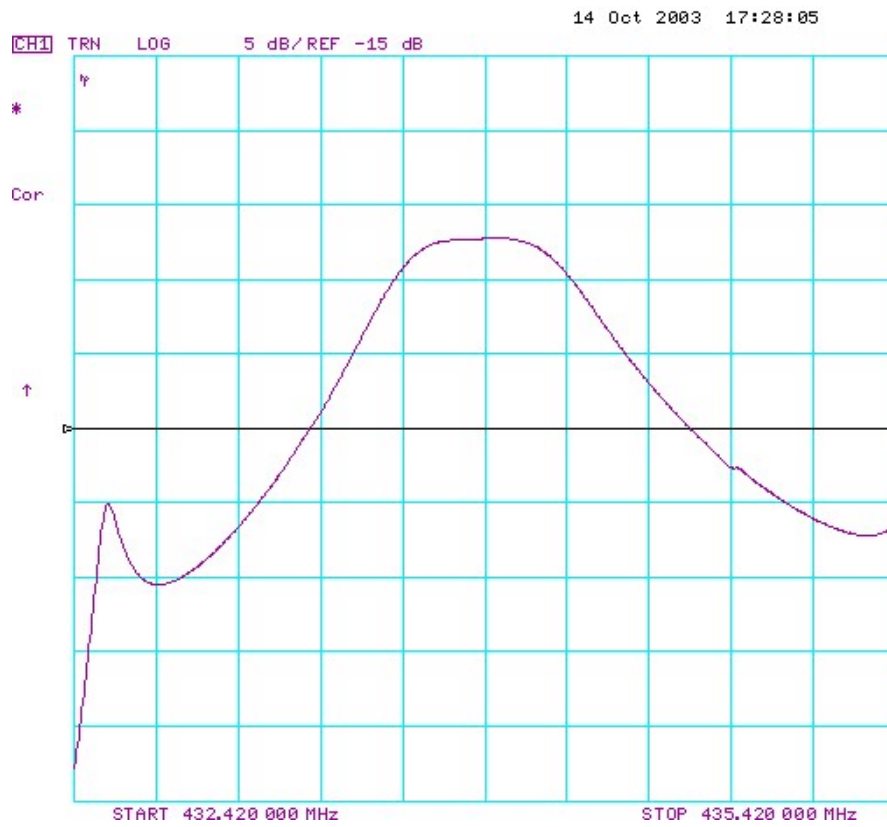

D. MEASUREMENT CIRCUIT:

HP Network analyzer

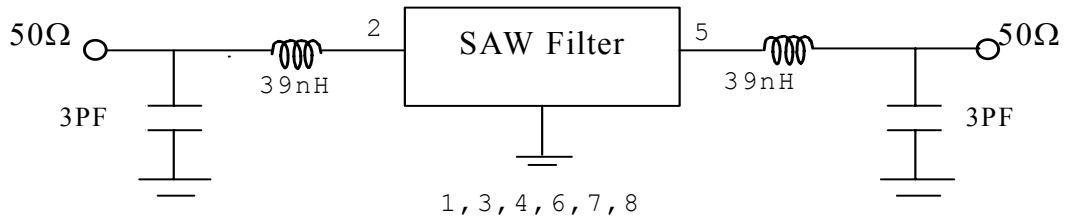

E. OUTLINE DRAWING:

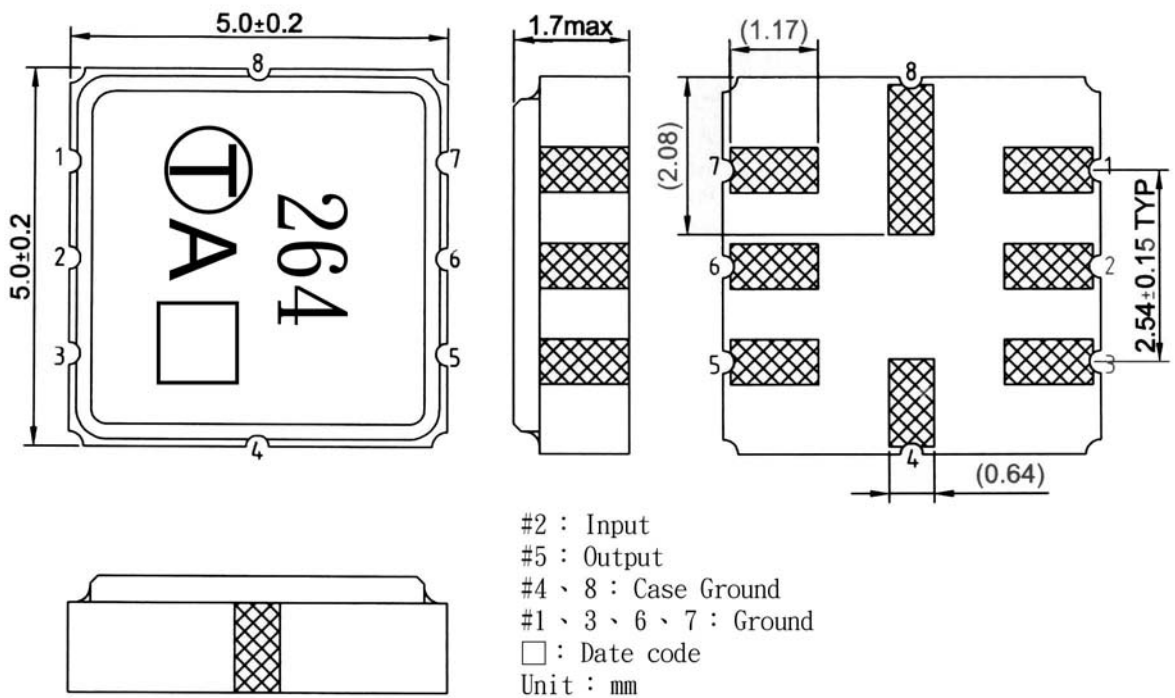

F. PACKING:

1. REEL DIMENSION

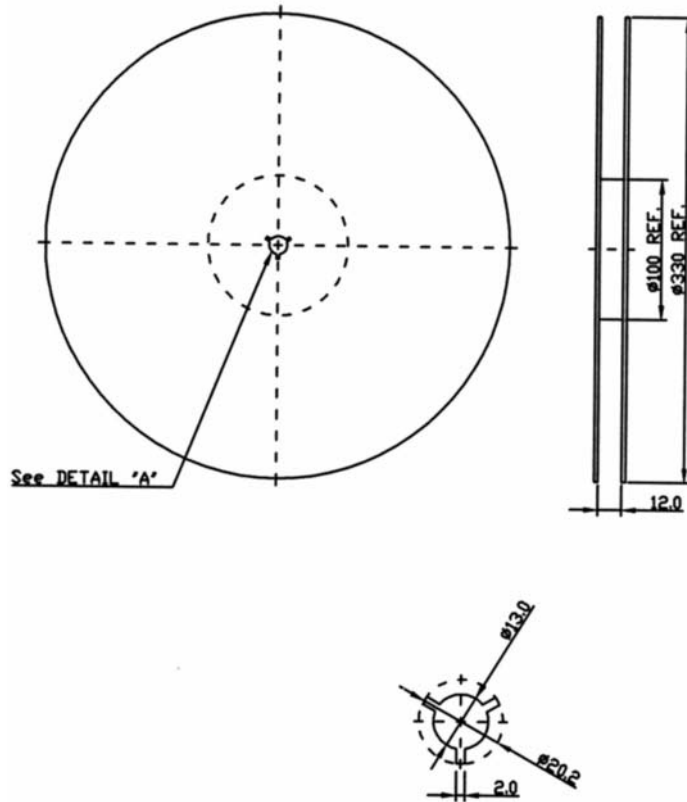

2. TAPE DIMENSION

