



Single Channel- CE Certified

Tunable Filter Instruments

Description

Frequency Devices' Model 950 instruments furnish the user with an 8-pole low-pass or high-pass filter that is tunable by front panel controls. The controls allow the user to select a corner frequency between 10 Hz and 50 kHz with 6 steps from each of two selectable ranges.

The instrument exhibits an input impedance of 1 Meg Ω shunted by 47pF to a single ended signal source. When configured in the differential mode, the instrument has a common mode rejection ratio (CMRR) which exceeds 60dB; in this mode the instrument presents an input impedance of 2 Meg Ω shunted by 47pF to a double ended single source. Front panel gain control also enables the operator to select a gain factor of 0, 10, or 20dB.

Standard operational features include:

- 1) Adjustable Frequency Control
- 2) Differential Input Amplifiers
- 3) Adjustable Gain Control
- 4) Off-set Adjustment
- 5) BNC Connectors for Signal I/O

Compact size and manual rotary switch front panel controls make 950 instruments a popular, cost effective, easy-to-use solution for signal conditioning applications in the following areas:

- Anti-aliasing Filters
- Biomedical/Biotechnology Applications
- Data Recording/Playback
- Data Smoothing
- EKG/EEG Signal Filtering
- FDM/PCM Signal Filtering
- Medical Research
- Industrial Process Control
- Seismic Analysis
- Vibration Analysis



Available Low-Pass Models:	Page
950L8B 8-pole Butterworth	3
950L8L 8-pole Bessel	3
Available High-Pass Models:	Page
950H8B 8-pole Butterworth	3
General Specifications:	6



Tunable Filter Instruments

BLOCK DIAGRAM

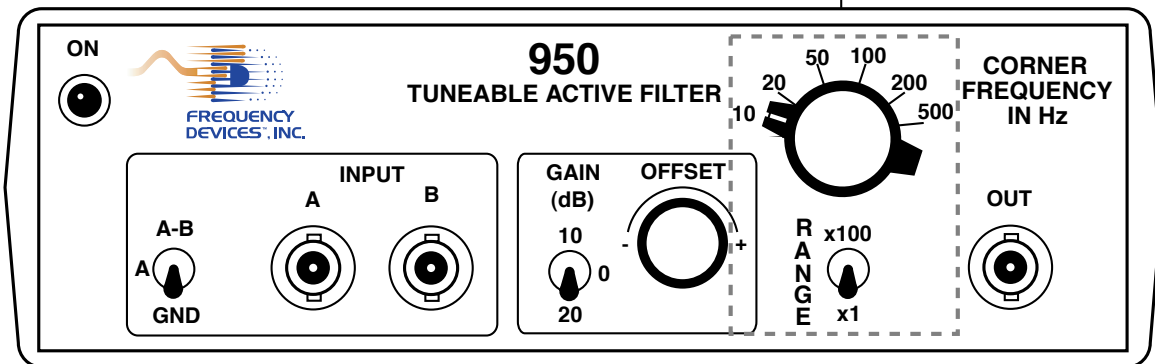
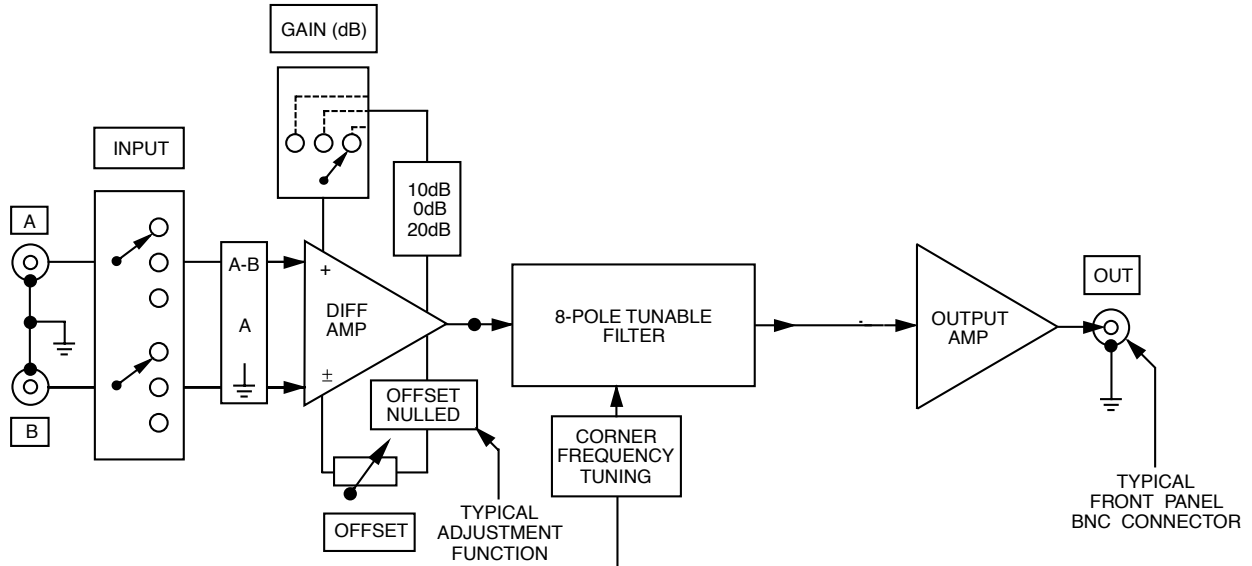



Tunable Filter Instruments

Model	950L8B	950L8L	Model	950H8B
Product Specifications	Low-Pass	Low-Pass		High-Pass
Transfer Function	8-Pole, Butterworth	8-Pole, Bessel	Transfer Function	8-Pole, Butterworth
Range f_c	10 Hz to 50.0 kHz	10 Hz to 50.0 kHz	Range f_c	10 Hz to 50.0 kHz
Theoretical Transfer Characteristics	Appendix A Page 9	Appendix A Page 4	Theoretical Transfer Characteristics	Appendix A Page 29
Passband Ripple (theoretical)	0.0 dB	0.0 dB	Passband Ripple (theoretical)	0.0 dB
DC Voltage Gain (non-inverting)	0 ± 0.1 dB typ. 0 ± 0.2 dB max.	0 ± 0.1 dB typ. 0 ± 0.2 dB max.	Voltage Gain (non-inverting)	0 ± 0.2 dB to 100 kHz 0 ± 0.5 dB to 120 kHz
Stopband Attenuation Rate	48 dB/Octave	48 dB/Octave	Power Bandwidth	120 kHz
Cutoff Frequency Accuracy	f_c ± 2% max. ± 0.05% typ. ± 2% max	f_c ± 2% max. ± 0.05% typ. ± 2% max.	Stopband Attenuation Rate	48 dB/Octave
Stability	± 0.01%/°C typ. ± 0.02%/°C max.	± 0.01%/°C typ. ± 0.02%/°C max.	Cutoff Frequency Accuracy	f_c ± 2% max. ± 0.05% typ. ± 2% max.
Amplitude Phase	-3 dB -360°	-3 dB -182°	Stability	± 0.01%/°C typ. ± 0.02%/°C max.
Filter Attenuation	0.12 dB 0.80 f_c 3.01 dB 1.00 f_c 60.0 dB 2.37 f_c 80.0 dB 3.16 f_c	1.91 dB 0.80 f_c 3.01 dB 1.00 f_c 60.0 dB 4.52 f_c 80.0 dB 6.07 f_c	Amplitude Phase	-3 dB -360°
Total Harmonic Distortion @ 1 kHz	<-90 dB typ.	<-90 dB typ.	Filter Attenuation	80.0 dB 0.31 f_c 60.0 dB 0.42 f_c 3.01 dB 1.00 f_c 0.00 dB 2.00 f_c
Narrow Band Noise (5 Hz - 100 kHz)	50 μV_{rms} typ.	50 μV_{rms} typ.	Total Harmonic Distortion @ 1 kHz	<-88 dB typ.
			Narrow Band Noise (5 Hz - 100 kHz)	100 μV_{rms} typ.



Location of Front Panel Terminals and Controls

Location of Front Panel Terminals and Controls

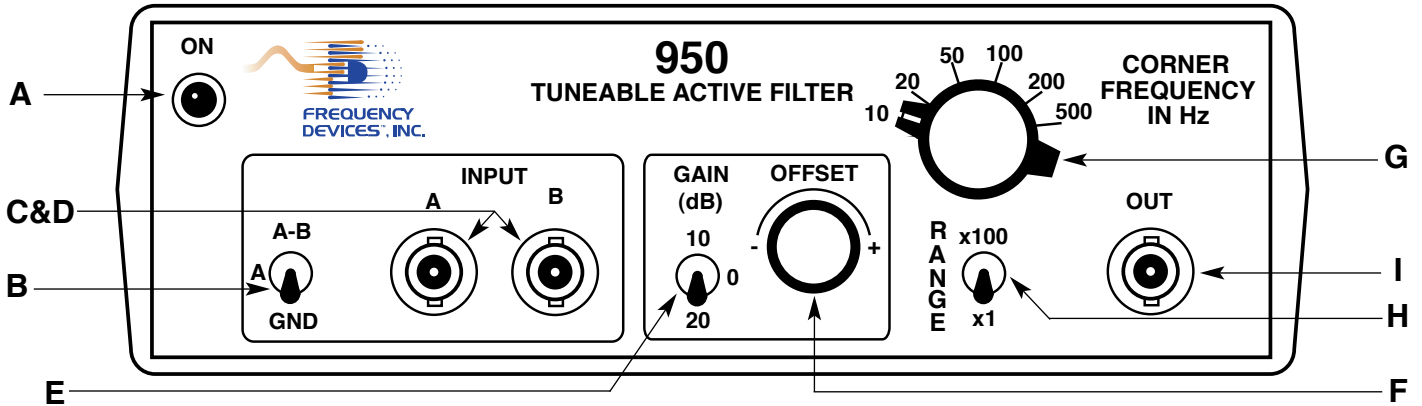

Location of Rear Panel Terminals and Controls

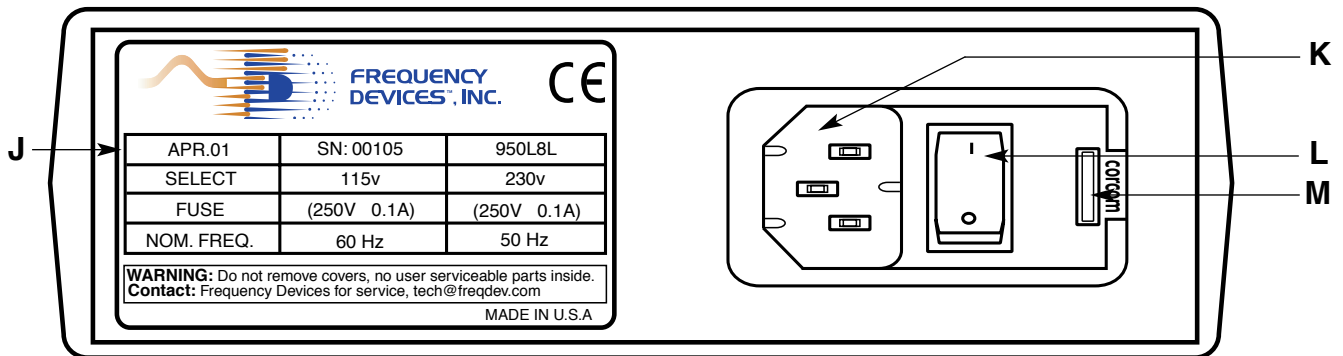

FRONT PANEL

A. POWER Status Lamp: This red LED indicates whether or not the power to the analog filter circuitry of a Model 950 instrument is on.

B. INPUT Switch: This three position toggle configures the instrument for either differential inputs (A-B), a single-ended input (A), or input nulling (GND) which grounds both the (A) and (B) input terminals.

C. & D. (A) and (B) Input Terminals: This pair of shielded, female BNC connectors accept signal inputs (A) and (B). The instrument applies a non-inverting gain to input (A) and an equal but opposite inverting gain to input (B) while the GAIN switch sets the magnitude of differential gain to 0, 10, or 20 dB. The BNC shields have been internally connected to the instrument ground.

E. GAIN Switch: This three-position toggle switch selects an overall filter gain of 0, 10, or 20dB.

F. OFFSET Adjust: This adjustment is intended to zero the offset that results from the instrument's own circuitry and does not provide for wide range offset to remove dc input signals.

G. CORNER FREQUENCY Selector Switch (10-500Hz): This six position rotary switch selects the digit value of the corner frequency. The switch selectable values are 10, 20, 50, 100, 200 and 500,

H. MULTIPLIER Selector Switch: This two-position toggle switch multiplies by a factor of either 1 or 100x, the value set on the CORNER FREQUENCY selector switch.

I. OUT Terminal: This terminal is a female BNC connector. The shield on the BNC is internally connected to the instrument ground.

REAR PANEL

J. IDENTIFICATION LABEL: This label identifies the date of manufacture, serial number, filter type and operating power requirements.

K. POWER CONNECTION: Denotes power plug location.

L. POWER ON/OFF Switch: A two-position toggle switch on the back panel Power Module that interrupts/completes the power circuit.

M. Voltage Selector Module: **115V Operation**

The power module window shows the operating voltage (115V or 230V). At time of shipment, the voltage window will be set to the 115V position.

230V Operation

For 230V operation, use a small flathead screwdriver to pry open the fuse module door. Remove the fuse cartridge, fuse clip and single fuse for 115V operation. Install two 5 X 20 mm 250V, 0.1A fuses into the fuse cartridge, rotate and insert fuse cartridge so 230V is visible in fuse module door when closed.



Operation and Application Guide Lines

Initial Setup

Select desired operating voltage 115 Vac or 230 Vac. See note "N" page four.

Set the POWER ON/OFF Switch to ON. A continuously lit POWER lamp indicates power applied. Allow the instrument a three-minute warm-up period to achieve thermal equilibrium.

To perform initial adjustment and/or operational testing, set the remaining front panel controls as follows:

- a) The CORNER FREQUENCY switch and the MULTIPLIER to the desired corner frequency.
- b) The OFFSET control to approximately mid-range.
- c) The GAIN switch to the desired value.
- e) The INPUT switch to ground (GND).

Connect a dc-coupled oscilloscope, of vertical sensitivity 10mV/CM or better, or a digital voltmeter (DVM) to the instrument front panel BNC connector labeled OUT.

Set the OFFSET control for a zero-volt reading on the scope.

Subsequent changes of CORNER FREQUENCY and GAIN control settings will introduce a small dc output offset, which should be zeroed for critical applications.

Leaving all other controls unchanged, set the Input Switch to (A-B) and apply a 5Vdc signal simultaneously to input BNCs (A) and (B). The voltage measured at the OUT BNC should be 5-5=0Vdc. This completes preliminary test and adjustment.

Corner Frequency Selection

To select a corner frequency, simply set the CORNER FREQUENCY switch and the MULTIPLIER switch for the desired numerical value.

The Differential Input

The instrument utilizes a differential input amplifier to reject prevalent forms of electrical interference, while presenting desirable input characteristics to the signal source requiring filtering. The differential input configuration is ideal for measuring the difference between two values rather than the values themselves. Bridge circuits utilizing strain gages, thermocouples and a variety of other types of transducers generate differential full-scale output voltages in the order of millivolts that are often superimposed upon volt-level reference and noise values.

The importance of CMRR

In actual system environments, each signal and power return conductor can generate an interference voltage proportional to the net conductor resistance and the electrical current level. Any such interference voltages appear as common mode signals to the amplifier, and are rejected as such.

Circuit model illustrating relationship between filter's differential input amplifier and external signal and error sources.

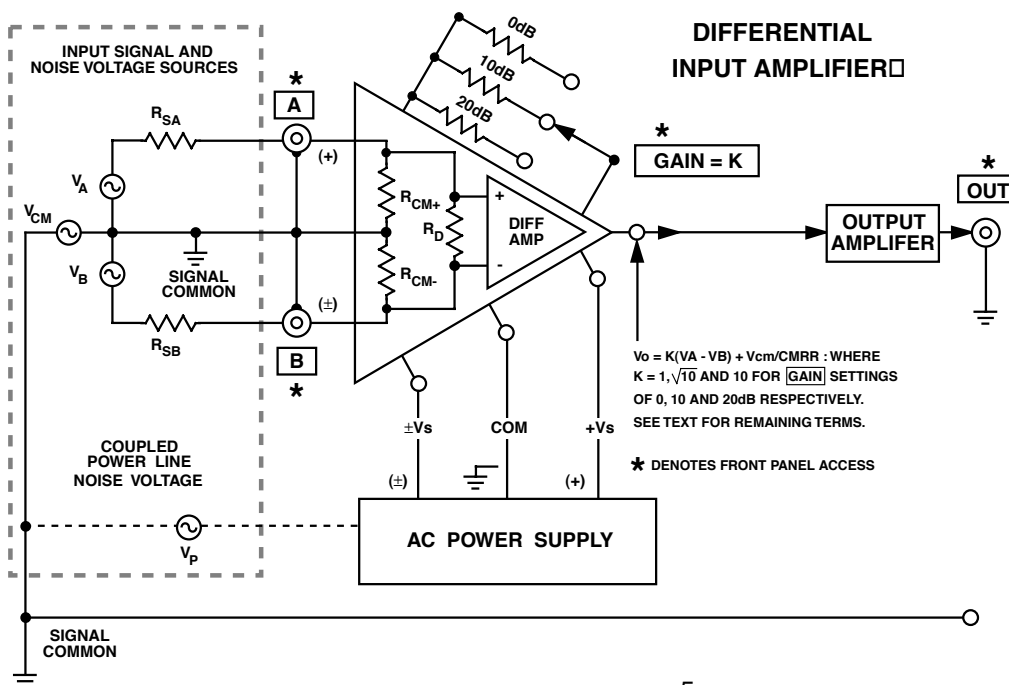



Specifications

(@25°C and rated Power Input)

Input Characteristics

Input Impedance:
 Differential 2 MΩ Shunted by 47pF
 Single Ended 1 MΩ Shunted by 47pF

Input Voltage:
 Linear Differential* 20V p-p (Gain Set at 0 dB)
 Max Safe Differential Any Continuous Value between ±75V
 Max Safe Common Mode Any Continuous Value between ±75V
 Bias Current 4 nA typ.; 20 nA max.
 Common Mode Rejection ratio with
 2kΩ source unbalance and 0 dB Gain > 60dB, dc to 50kHz

Output Characteristics

Full Power Bandwidth dc to 50kHz
 Related Output 10V p-p for $R_L = 50\Omega$
 20V p-p for $R_L = 2k\Omega$
 Short Circuit Output Current +/-100 mA continuous
 Output Protection +/-200 mA without damage
 Short Circuit to Ground Only
 Output Impedance 50 Ω
 Offset Voltage Adjustable to Zero at Front Panel
 (Range +/-500mV dc)

Power Supply

AC Line Operation:
 Power 6 Watts max.
 Voltage Frequency Range-Rear Panel:
 115 V 105 to 125Vac @ 50/60Hz
 230 V 210 to 250Vac @ 50Hz
 Fuse 0.1 Amp

Temperature

Operating Temperature: 0 °C to +50 °C
 Storage Temperature -25 °C to +70 °C

Mechanical

Dimensions 2.375"H x 7.0"W x 8.3"D
 6.03cmH x 17.75cmW x 21.08cmD
 Weight 1.5 lbs; 0.68 kgs.
 Case Material ABS plastic
 Color PC Bone

* Signal plus common mode voltage cannot exceed 20V peak for a linear output.

Typical Common Mode Rejection Ratio

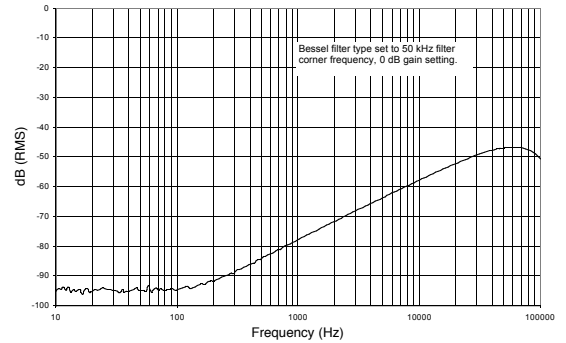

Typical Output Noise

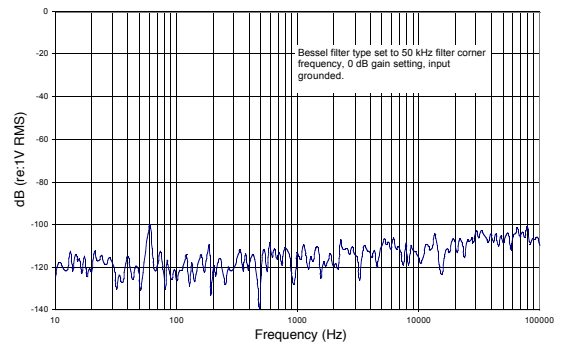



Appendix A

Theoretical Transfer Characteristics

f/fc (Hz)	Amp (dB)	Phase (deg)	Delay ¹ (sec)
0.00	0.00	0.00	.506
0.10	-0.029	-18.2	.506
0.20	-0.117	-36.4	.506
0.30	-0.264	-54.7	.506
0.40	-0.470	-72.9	.506
0.50	-0.737	-91.1	.506
0.60	-1.06	-109	.506
0.70	-1.45	-128	.506
0.80	-1.91	-146	.506
0.85	-2.16	-155	.506
0.90	-2.42	-164	.506
0.95	-2.71	-173	.506
1.00	-3.01	-182	.506
1.10	-3.67	-200	.506
1.20	-4.40	-219	.506
1.30	-5.20	-237	.506
1.40	-6.10	-255	.505
1.50	-7.08	-273	.504
1.60	-8.16	-291	.502
1.70	-9.36	-309	.498
1.80	-10.7	-327	.492
1.90	-12.1	-345	.482
2.00	-13.7	-362	.468
2.25	-18.1	-402	.417
2.50	-23.1	-436	.352
2.75	-28.3	-465	.291
3.00	-33.4	-489	.241
3.25	-38.3	-509	.201
3.50	-43.1	-526	.170
4.00	-51.8	-552	.126
5.00	-66.8	-587	.077
6.00	-79.2	-610	.052
7.00	-89.8	-626	.038
8.00	-99.0	-638	.029
9.00	-107	-647	.023
10.0	-114	-655	.018

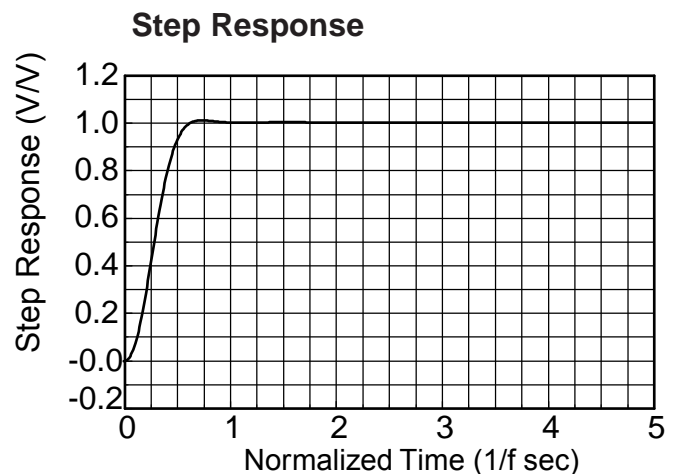
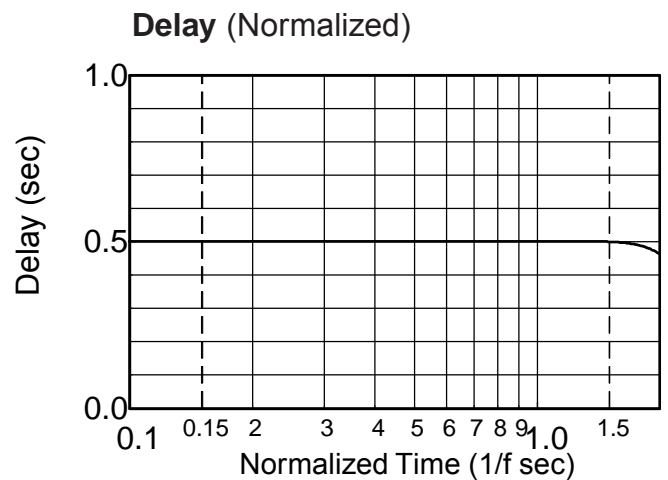
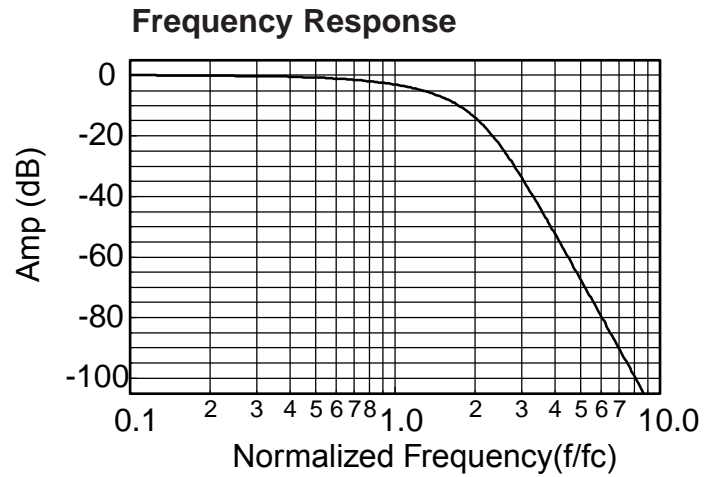

¹ **Normalized Group Delay:**
The above delay data is normalized to a corner frequency of 1.0Hz. The actual delay is the normalized delay divided by the actual corner frequency (fc).

$$\text{Actual Delay} = \frac{\text{Normalized Delay}}{\text{Actual Corner Frequency (fc) in Hz}}$$



Appendix A

Theoretical Transfer Characteristics

f/fc (Hz)	Amp (dB)	Phase (deg)	Delay ¹ (sec)
0.00	0.00	0.00	.816
0.10	0.00	-29.4	.819
0.20	0.00	-59.0	.828
0.30	0.00	-89.1	.843
0.40	0.00	-120	.867
0.50	0.00	-152	.903
0.60	-0.001	-185	.956
0.70	-0.014	-221	1.04
0.80	-0.121	-261	1.19
0.85	-0.311	-283	1.29
0.90	-0.738	-307	1.40
0.95	-1.58	-333	1.48
1.00	-3.01	-360	1.46
1.10	-7.48	-408	1.17
1.20	-12.9	-445	.873
1.30	-18.2	-472	.672
1.40	-23.4	-494	.540
1.50	-28.2	-511	.448
1.60	-32.7	-526	.380
1.70	-36.9	-539	.328
1.80	-40.8	-550	.287
1.90	-44.6	-560	.253
2.00	-48.2	-568	.226
2.25	-56.3	-586	.174
2.50	-63.7	-600	.139
2.75	-70.3	-611	.113
3.00	-76.3	-621	.094
3.25	-81.9	-629	.080
3.50	-87.1	-635	.069
4.00	-96.3	-646	.052
5.00	-112	-661	.033
6.00	-125	-671	.023
7.00	-135	-678	.017
8.00	-144	-683	.013
9.00	-153	-687	.010
10.0	-160	-691	.008

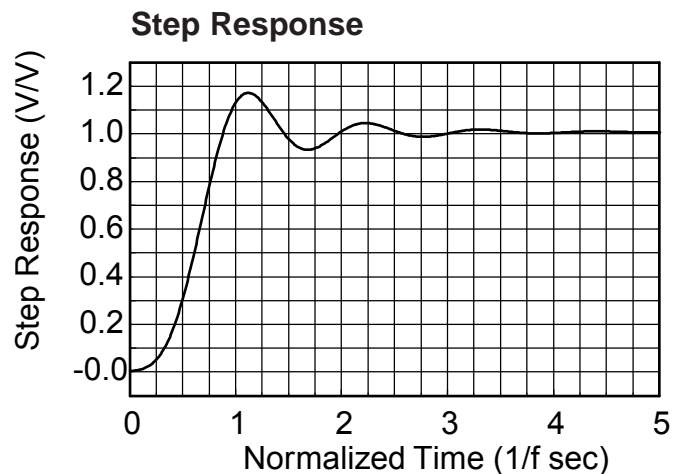
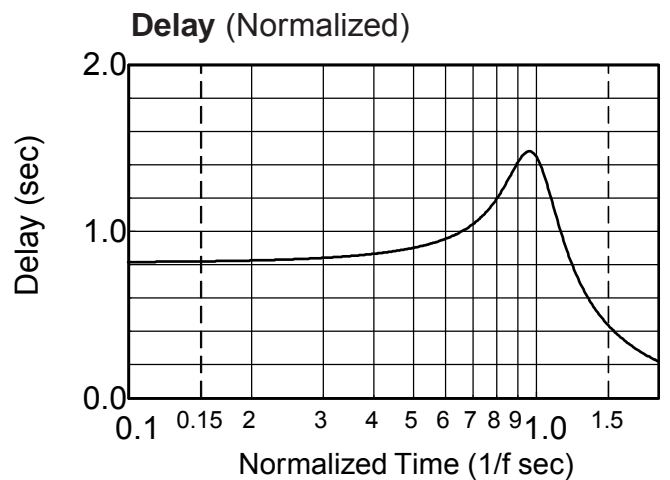
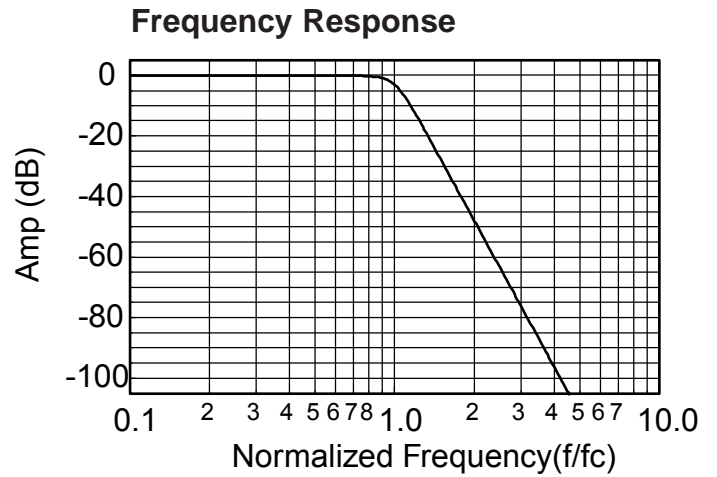

1. Normalized Group Delay:

The above delay data is normalized to a corner frequency of 1.0Hz. The actual delay is the normalized delay divided by the actual corner frequency (fc).

$$\text{Actual Delay} = \frac{\text{Normalized Delay}}{\text{Actual Corner Frequency (fc) in Hz}}$$



Theoretical Transfer Characteristics

f/fc (Hz)	Amp (dB)	Phase (deg)	Delay¹ (sec)
0.10	-160	691	0.819
0.20	-112	661	0.828
0.30	-83.7	631	0.843
0.40	-63.7	600	0.867
0.50	-48.2	568	0.903
0.60	-35.5	535	.956
0.70	-24.8	499	1.04
0.80	-15.6	459	1.19
0.85	-11.6	437	1.29
0.90	-8.06	413	1.40
0.95	-5.15	386	1.48
1.00	-3.01	360	1.46
1.20	-0.229	275	0.873
1.40	-0.020	226	0.540
1.60	-0.002	194	0.380
1.80	0.00	170	0.287
2.00	0.00	152	0.226
2.50	0.00	120	0.139
3.00	0.00	99.2	0.094
4.00	0.00	74.0	0.052
5.00	0.00	59.0	0.033
6.00	0.00	49.0	0.023
7.00	0.00	42.1	0.017
8.00	0.00	36.8	0.013
9.00	0.00	32.7	0.010
10.0	0.00	29.4	0.008

Frequency Response

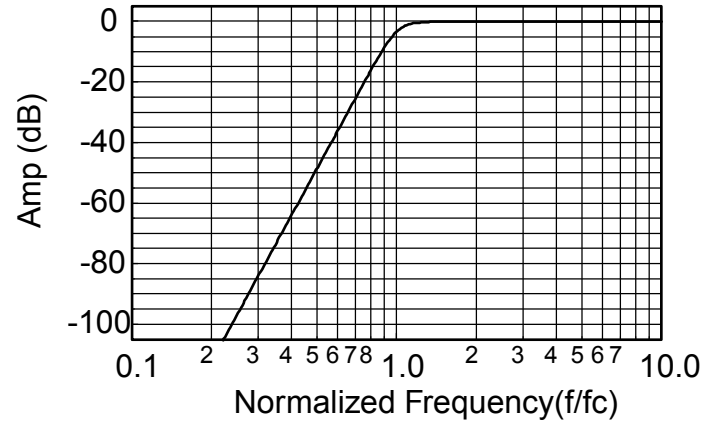

1. Normalized Group Delay:

The above delay data is normalized to a corner frequency of 1.0Hz. The actual delay is the normalized delay divided by the actual corner frequency (fc).

$$\text{Actual Delay} = \frac{\text{Normalized Delay}}{\text{Actual Corner Frequency (fc) in Hz}}$$