

Load Insensitive Mixer

Rev. V3

Features

- LO 1 to 3400 MHz
- RF 1 to 3400 MHz
- IF 1 to 2000 MHz
- LO Drive +10 dBm (nominal)
- Insensitive to VSWR Mismatch
- High Intercept +18 dBm (typ)

Description

The M4T is a termination insensitive mixer, designed for use in military, commercial and test equipment applications. The design utilizes Schottky bridge quad diodes, broadband ferrite baluns and internal loads to provide excellent performance without degradation due to external VSWR mismatches. The use of high temperature solder and welded assembly processes used internally makes it ideal for use in semi-automated and automated assembly. Environmental screening available to MIL-STD-883, MIL-STD-202, or MIL-DTL-28837, consult factory.

Product Image

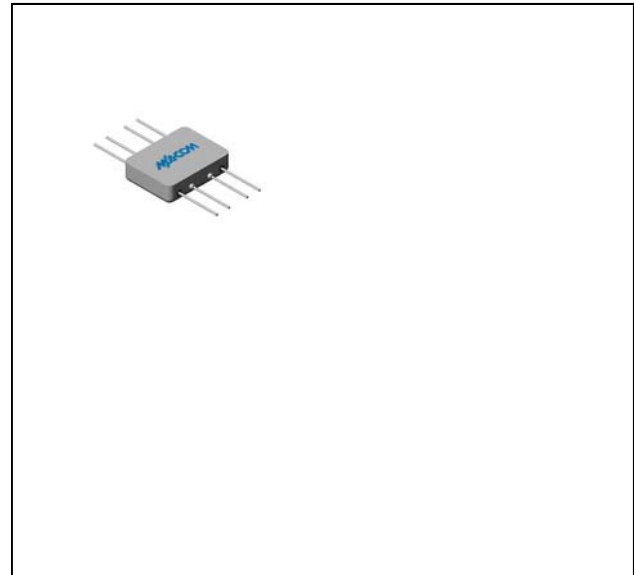

Ordering Information

Part Number	Package
M4T	Flatpack

Electrical Specifications: $Z_0 = 50\Omega$ $Lo = +10$ dBm (Downconverter application only)

Parameter	Test Conditions	Units	Typical	Guaranteed	
				+25°C	-54° to +85°C
SSB Conversion Loss (max)	fR = 0.005 to 1.0 GHz, fL = 0.005 to 1.0 GHz, fl = 0.001 to 0.5 GHz fR = 0.001 to 3 GHz, fL = 0.001 to 3 GHz, fl = 0.001 to 1.5 GHz fR = 0.001 to 3.4 GHz, fL = 0.001 to 3.4 GHz, fl = 0.001 to 2 GHz	dB	6.5	7.5	8.0
			8.0	9.0	9.5
			9.0	10.5	11.0
SSB Noise Figure (max)	Within 1 db of conversion loss	dB	—	—	—
Isolation, L to R (min)	fL = 0.01 to 1.5 GHz	dB	40	35	33
	fL = 0.01 to 3.4 GHz		30	25	23
Isolation, L to I (min)	fL = 0.01 to 1.5 GHz	dB	40	35	33
	fL = 0.01 to 3.4 GHz		30	25	23
Isolation, R to I (min)	fR = 0.001 to 3.4 GHz	dB	25		
1 dB Conversion Comp.	fL = +10 dBm	dBm	+6		
Input IP3	fR1 = 1.9 GHz at -10 dBm, fR2 = 1.91 GHz at -10 dBm, fL = 2 GHz at +10 dBm	dBm	+18		

Typical Performance Curves

Conversion Loss

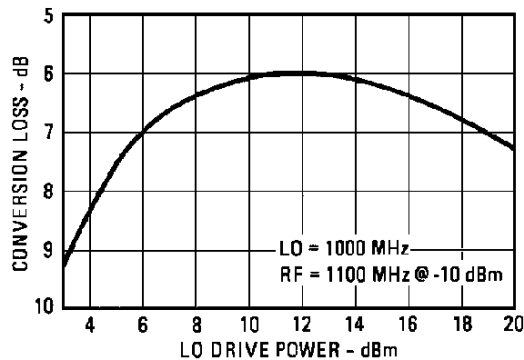

Conversion Loss vs. Drive Level: The minimum recommended drive level is +7 dBm. The maximum recommended drive level is +18 dBm.

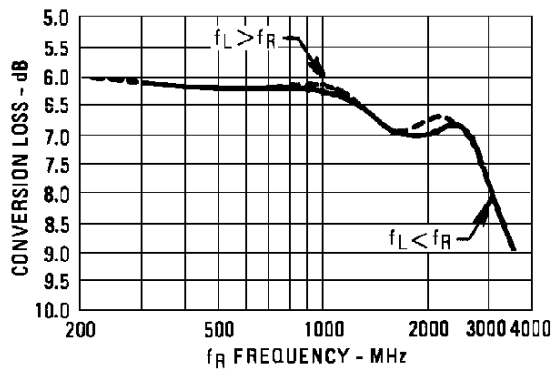

Conversion Loss vs. Input Frequency: Conversion loss of the mixer when used in an SSB system. Data plotted for a f_L of 100 MHz with f_L at +10 dBm.

VSWR

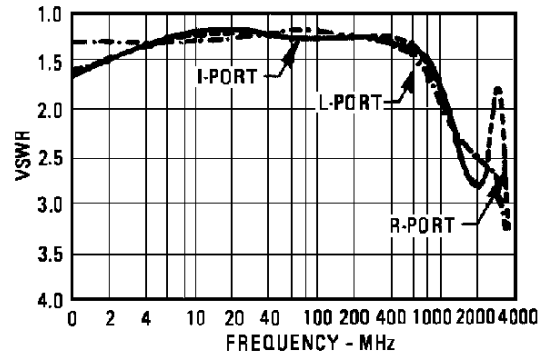

VSWR vs. Frequency: VSWR is the L-, I-, and R-ports in a 50 ohm system with f_L at +10 dBm. R- and I-port VSWR plotted with f_L at 1500 MHz.

Isolation

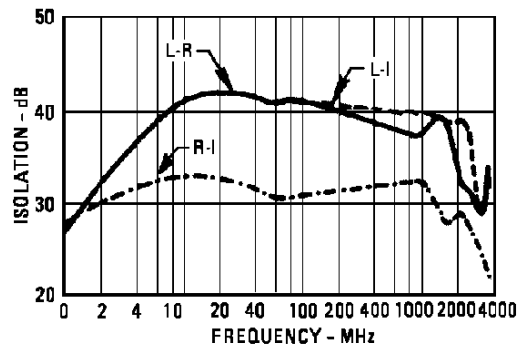

Isolation vs. Frequency: Level of f_L signal fed through to R- and I-port with respect to the level of the f_L signal at L-port. R-I Isolation plotted with f_L at 1500 MHz.

Load Insensitive Mixer

Rev. V3

Absolute Maximum Ratings

Parameter	Absolute Maximum
Operating Temperature	-54°C to +100°C
Storage Temperature	-65°C to +100°C
Peak Input Power	+27 dBm max @ +25°C +17 dBm max @ +100°C
Peak Input Current	50 mA DC

Outline Drawing: Flatpack *

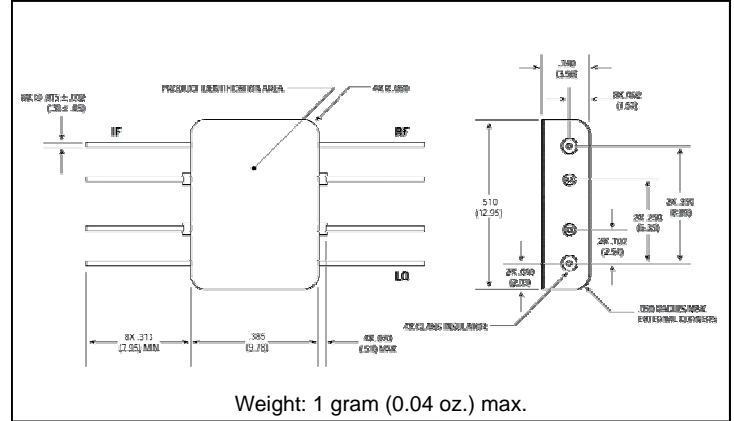

* Dimensions are inches (millimeters) ± 0.015 (0.38) unless otherwise specified.