

ST1115C/ST1115D

Version : A.005
Issue Date : 2004/06/30
File Name : SP-ST1115CD-A.005.doc
Total Pages : 13

PWM Speed Control
Double Coil Brushless DC Motor Driver



SILICON TOUCH TECHNOLOGY INC.
新竹市科學園區展業一路九號七樓之一
9-7F-1 Prosperity Road I Science-Based Industrial Park
Hsinchu, Taiwan 300, R.O.C.
Tel : 886-3-5645656 Fax : 886-3-5645626

ST1115C/ST1115D

PWM Speed Control Double Coil Brushless DC Motor Driver

General Specifications

The ST1115 serial IC is a driver with pulse-width modulated (PWM) speed control for two-phase unipolar DC brushless fan applications. The device is used as an interface between a HALL effect latch and a double coil load. Besides its high-efficiency driving capability, the ST1115 has various functions such as rotation detection (for ST1115C only), tachometer signal output (for ST1115D only), linear fan speed control, exterior PWM control, locked-rotor protection and self-restart.

The speed command can be either a PWM signal or simply a voltage reference according to the applications. For the temperature-proportional fan speed control, the voltage command can be generated by an external temperature sensor, typically a thermistor-resistor divider. If the motor rotation is stalled by external force or obstacles, overdrive current (or lock current) may incur coil overheat/burning. To prevent coil overheat/burning, this device incorporates locked-rotor protection circuitry to shut down the drivers. After the motor locking is released, the drivers can be automatically powered up by the internal self-restart circuitry.

Features and Benefits

- High-efficiency PWM fan speed control
- Linear temperature-speed control with minimum external circuitry
- High output sinking current capability
- Lock protection and automatic self-restart
- Tachometer output
- Directly connectable to a HALL Latch IC
- Thin, highly reliable package (SOP8, MSOP8)

Pin Assignment

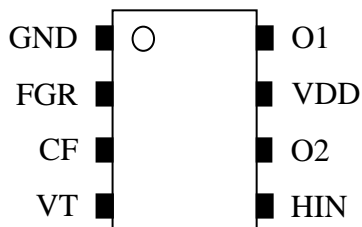

Pin NO.	Pin Name	Description
1	GND	Ground
2	FGR	Rotation Detection Output (for ST1115C) Fan Tachometer Output (for ST1115D)
3	CF	Lock Timing Capacitor
4	VT	Input pin for PWM duty control
5	HIN	Input pin from Hall Latch IC
6	O2	Output driver 2
7	VDD	Power supply
8	O1	Output driver 1

Absolute Maximum Ratings ($T_A=25^{\circ}\text{C}$)

Characteristic	Symbol	Rating	Unit
Supply Voltage	V_{DD}	14	V
Input Voltage	V_{IN}	$V_{DD}+0.4$	V
Output Current at Lock	I_{OUT}	1000	mA
Output Current at Operating	I_{OPR}	600	mA
Power Dissipation (SOP8)	P_D	0.68	W
Power Dissipation (MSOP8)	P_D	0.48	W
Operating Temperature Range	T_A	-40 ~ 125	$^{\circ}\text{C}$
Storage Temperature Range	T_S	-65 ~ 150	$^{\circ}\text{C}$

Electrical Characteristic ($T_A = 25^\circ\text{C}$ & $V_{DD} = 12\text{ V}$)

Characteristic	Sym.	Condition	Limit			Unit
			Min.	Typ.	Max.	
Supply Voltage	V_{DD}	Operating	3	12	14	V
Quiescent Current	I_{DD}	No load, All Inputs = 0V or V_{DD}	-	3	-	mA
HIN Input Terminal						
Input Voltage "H"	V_{IH}	-	10	-	12.4	V
Input Voltage "L"	V_{IL}	-	-0.4	-	1.5	V
Input Current "H"	I_{IH}	$V_{IN} = V_{DD}$	-	-	± 1	μA
Input Current "L"	I_{IL}	$V_{IN} = 0\text{ V}$	-	± 0.3	± 0.5	mA
O1 / O2 Output Terminal ($T_J = 25^\circ\text{C}$)						
Output Voltage High	V_{OH}	-	-	-	-	mV
Output Voltage Low	V_{OL}	$I_{OUT} = 250\text{mA}$	-	250	-	mV
FG Open-Drain Terminal ($T_J = 25^\circ\text{C}$)						
Output Leakage Current	I_{Leak}	$V_{FG} = 12\text{V}$	-	-	10	μA
Output Current	I_{FG}	$V_{FG} = 0.2\text{V}$	10	-	-	mA
Output Voltage High	V_{FGOH}	-	-	-	15	V
VT PWM Speed Control Terminal ($T_J = 25^\circ\text{C}$)						
VT Threshold Voltage	V_{THL}	100% PWM Duty Cycle	-	3.88	-	V
VT Threshold Voltage	V_{THH}	50% PWM Duty Cycle	-	3.18	-	V
Lock Protection and Restart						
Lock Protection Time	T_{OFF}	The capacitor connected to the CF pin is of value C_F μF .	-	$2.5 \cdot C_F$	-	sec
Ratio of Protection Time to Restart Time	R_{LOCK}	T_{OFF} / T_{ON}		3		

HIN Input and the Output Driver States

HIN	O1	O2
H	OFF	ON
L	ON	OFF

Internal PWM Duty Cycle v.s. VT Input

Different voltage levels of the VT pin correspond to different internal PWM duty cycles. The relation of VT v.s. Duty Cycle is shown below, which illustrates a linear relation within the range of 3.18~3.88 V ($V_{DD}=12\text{ V}$). If the linear temperature control is desired, the VT terminal is biased in this linear region through a thermistor-resistor divider. In this way, the fan speed can vary linearly with respect to the temperature variation; the higher temperature results in the faster speed. Additionally, applying the exterior PWM command to the VT terminal can also control the fan speed. Note that the low level and high level of the exterior PWM command must be lower than 3.18 V and higher than 7.7 V ($V_{DD}=12\text{ V}$), respectively. The exterior PWM is active low.

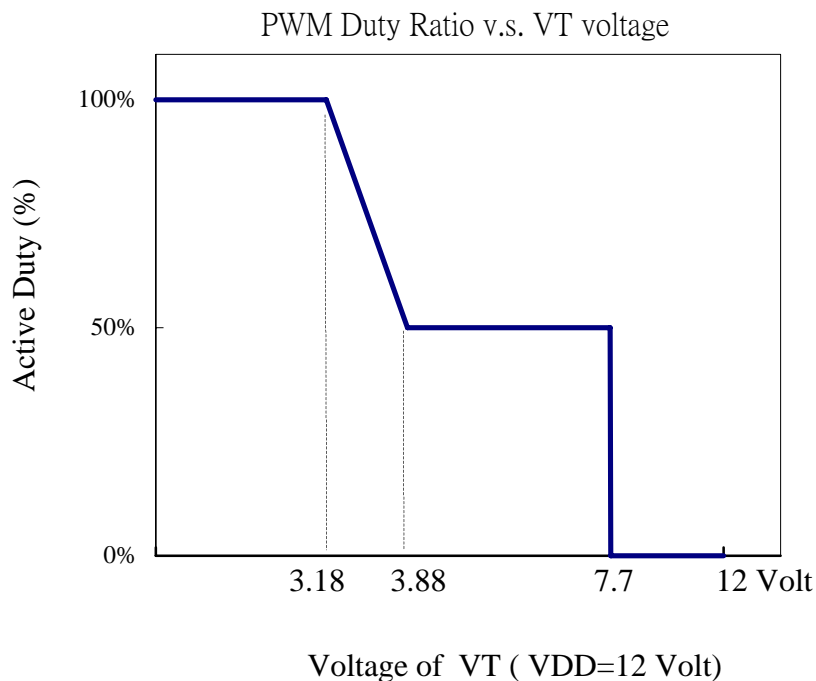

Application Circuits and Designer's Notes

1. Temperature-sensing fan speed control —Refer to Figure 1.

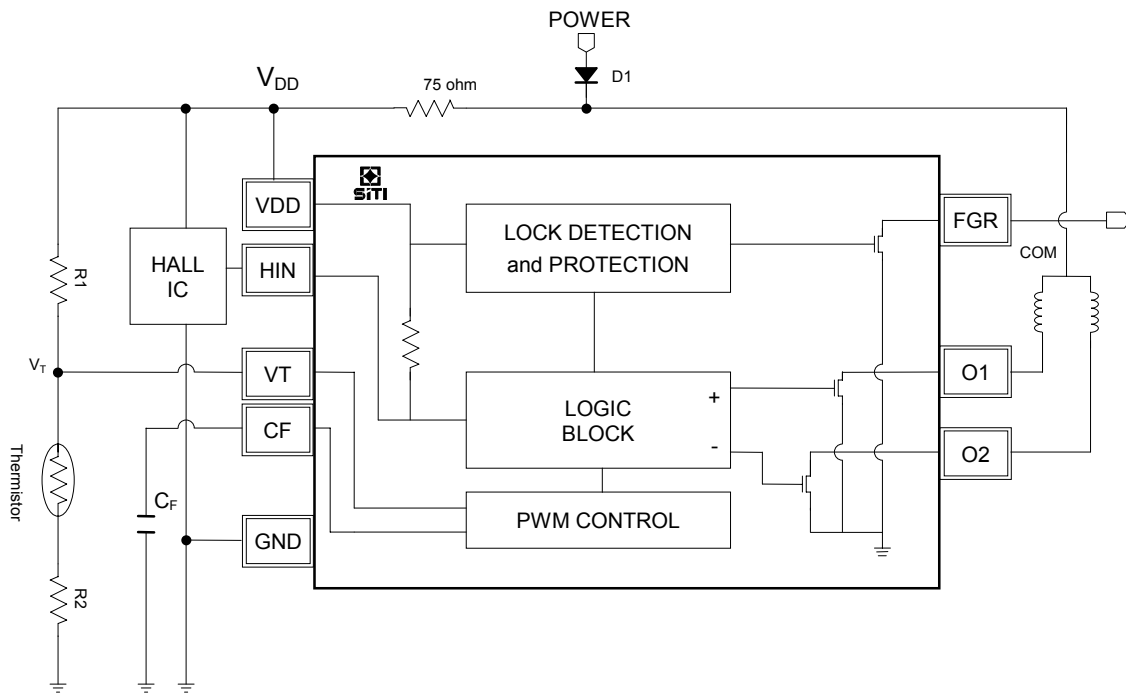

Figure 1. Fan speed control by the external temperature sensor.

- (1) If the linear temperature control is desired, the VT terminal is connected to a thermistor-resistor divider, as shown in Fig. 1. In this way, the fan speed can vary linearly with respect to the temperature variation; the higher temperature results in the faster speed.
- (2) Figure 2 illustrates the desired temperature-speed curve. Assume that the resistance of the thermistor is R_{T1} when the temperature is at $T1$, and R_{T2} at $T2$. Also assume that the voltage $V1$ applied to the VT pin will result in the fan speed rpm1, and $V2$ applied to the VT pin yielding rpm2. Note that the relation between the VT voltage and the fan speed depends on the size and the coil impedance of the fan. To obtain the desired temperature-speed curve, the resistance values of $R1$ and $R2$ in Fig. 1 can be roughly selected by the following equations.

$$R2 = \frac{V1(V2 - V_{DD})R_{T2} + V2(V_{DD} - V1)R_{T1}}{V_{DD}(V1 - V2)}$$

$$R1 = \frac{(V_{DD} - V1)(R_{T1} + R2)}{V1}$$

where V_{DD} denotes the voltage at the VDD pin, see Fig. 1. Normally, V_{DD} is around 10.8 Volt, which may slightly vary with the variation of the driving current.

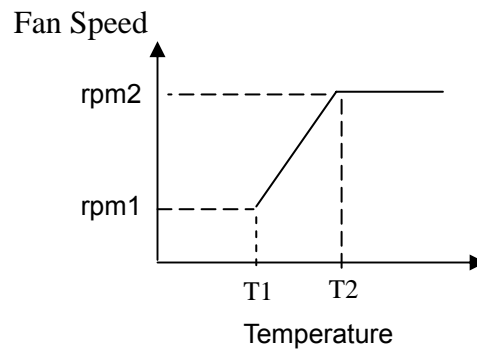

Figure 2. Desired Temperature-Speed Curve

- (3) The FGR pin provides the rotation detection output for ST1115C and the tachometer output for ST1115D. FGR is an open-drain output with a built-in 100kΩ pullup resistor. An additional resistor can be used to pull up the FGR voltage to the appropriate level, which depends on the voltage level of the monitoring/control system.

2. **Temperature-control Fan Switch** —Refer to Figure 3.

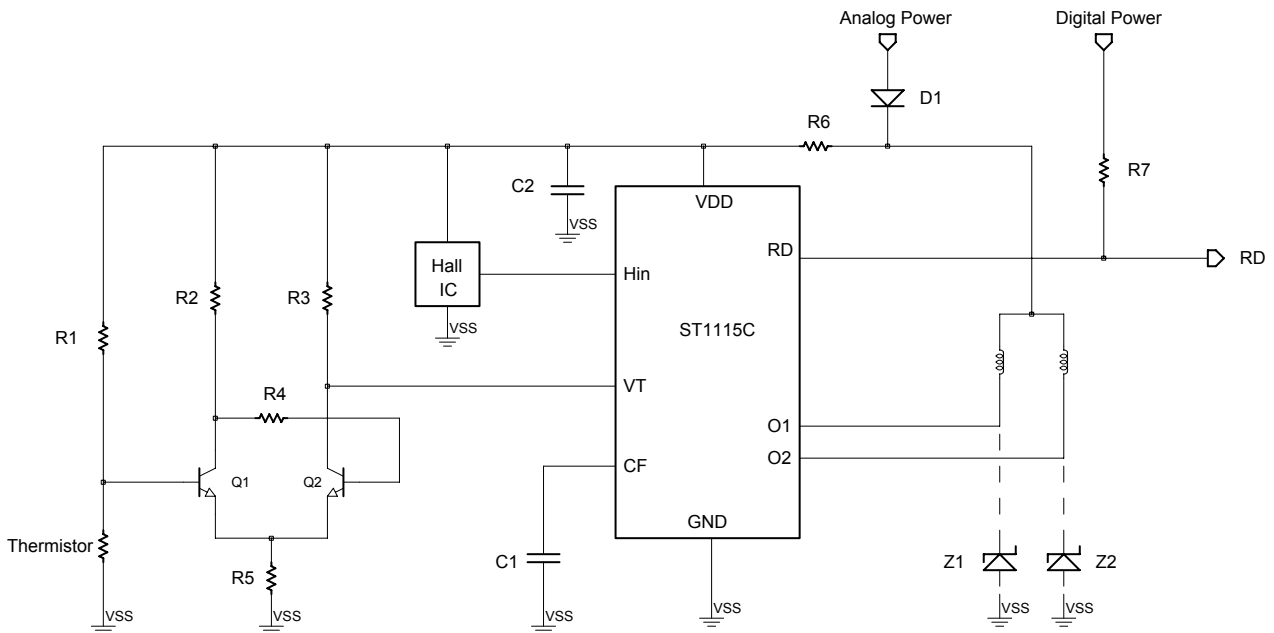

Figure 3. Temperature-control Fan Switch (where ST1115C is shown for illustration).

(1) Figure 3 shows the temperature-control fan switch circuit, where the fan either stops or rotates at the full speed, depending on some temperature threshold. Figure 4 indicates the graph of the fan speed as a function of the temperature. The temperature threshold is T with the hysteresis T_2-T_1 .

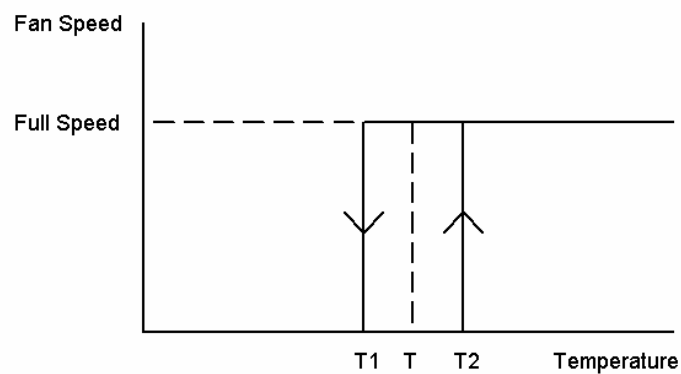

Figure 4.

3. Fan speed control by the PWM command —Refer to Figure 5.

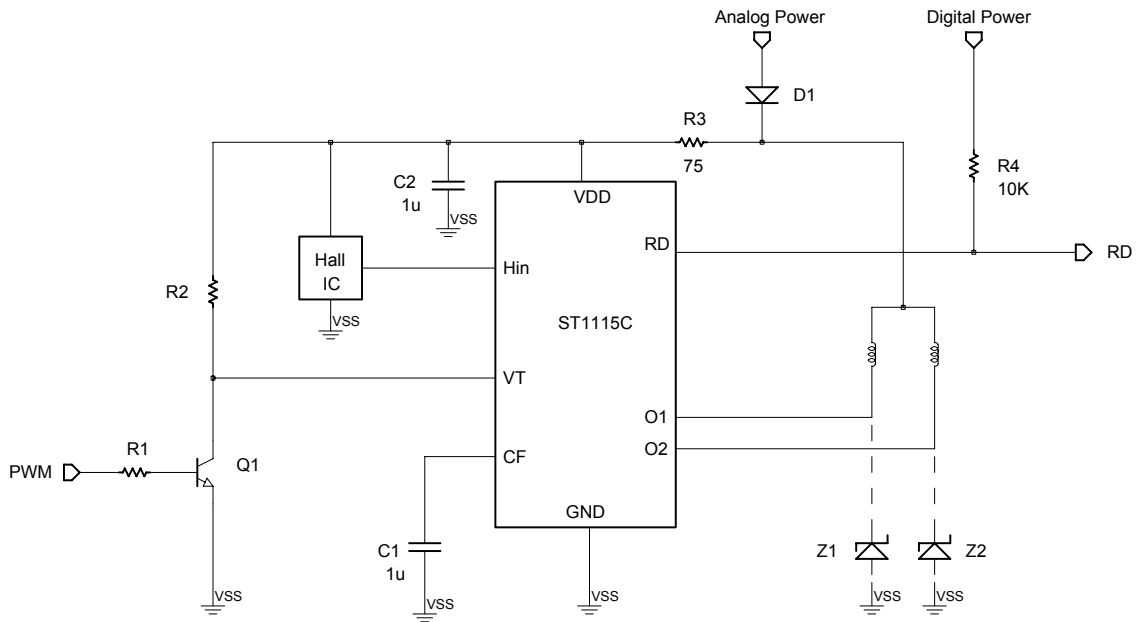

Figure 5. Fan speed control via the PWM command.

- (1) Figure 5 shows the application circuit, where the fan speed is directly controlled by the PWM command. The BJT Q1 together with resistors R1 and R2 constitutes an inverting level shifter, which is responsible for translating the voltage level of the PWM command to the VDD voltage level of the drive IC. In this way, the voltage level of the PWM command can be very low, say, 2 Volt, for example.
- (2) For this circuit, the PWM command is active high and its frequency range is 200 Hz ~ 40 KHz. If low acoustic noise is desired, the 20 KHz~40 KHz of the PWM frequency range is recommended.

4. Operating as a pre-driver—Refer to Figure 6.

(1) When a large fan is used, the driving current may be too large for ST1115 directly driving the fan. In this case, ST1115 may operate as a pre-driver, as illustrated in Fig. 6. Q1 and Q2 are PNP BJT, working as driving switches. The fan speed is controlled via the VT terminal, which can be connected to a thermistor-resistor divider or a PWM generator.

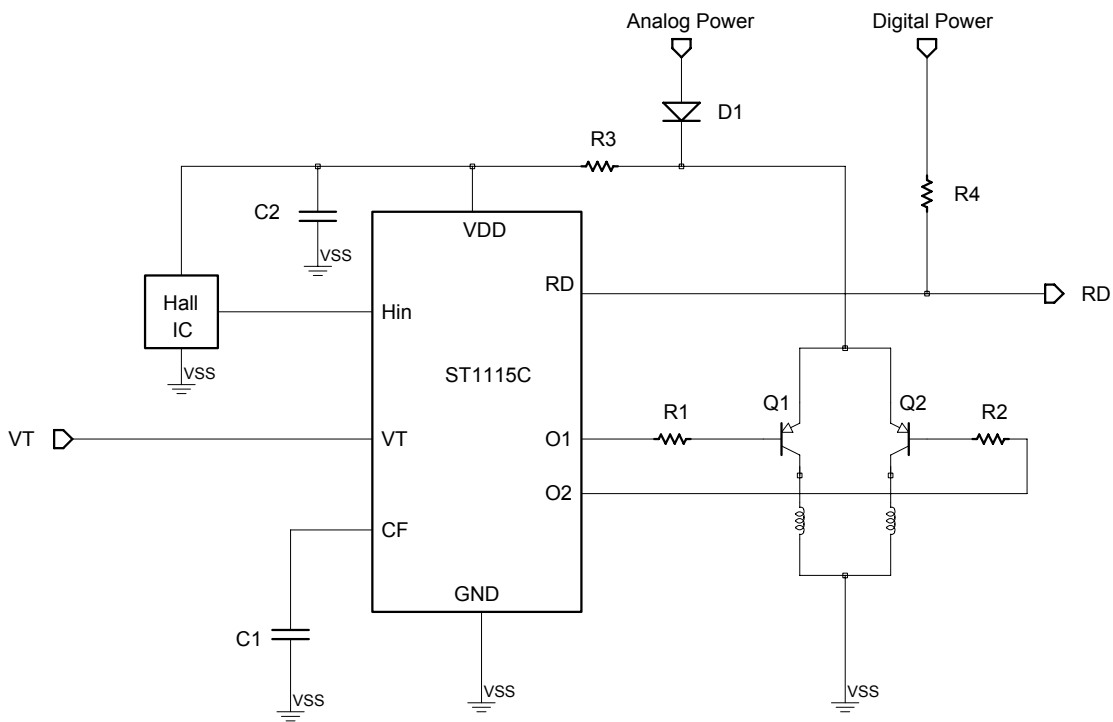

Figure 6. ST1115 operates as a pre-driver.

5. Lock protection and restart timing

- (1) If the fan is locked, ST1115 will turn the driver off, avoiding high-current damage of the driver. After a period T_{OFF} of turning off, it will try to restart the fan by turning the driver on for a short time T_{ON} . The proportion of T_{OFF} to T_{ON} is around 3:1. The absolute values of T_{OFF} and T_{ON} depend on the capacitor connected to the CF pin.
- (2) Assume that the capacitance of the capacitor connected to the CF pin is C_F . The lock protection time is roughly $3 \cdot C_F$ second. The recommended capacitance C_F is $1 \mu F$ for roughly 2.5-sec lock protection and 800-msec lock restart.

6. Power Dissipation v.s. Temperature

- (1) The power dissipation is affected by various factors, such as the supply voltage, the output current, and loading. It is important to ensure the applications do not exceed the allowable power dissipation of the IC package. The allowable motor driver power dissipation versus temperature is depicted as follows:

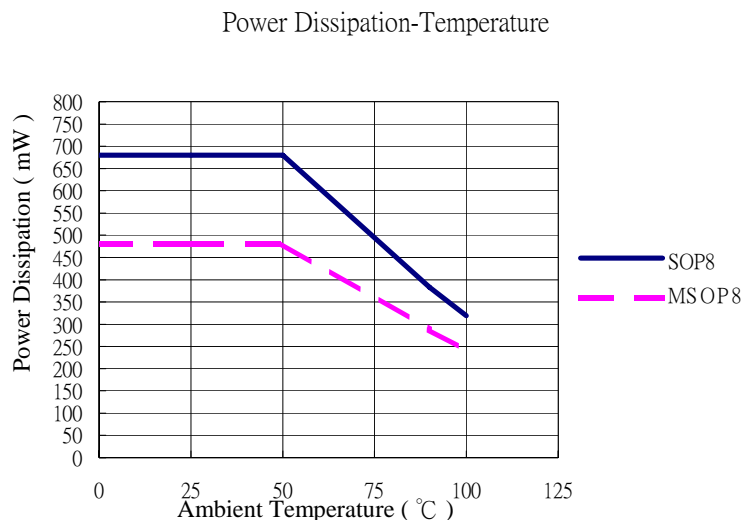

Package Specifications

SOP8 : ST1115C_TSP1 / ST1115D_TSP1

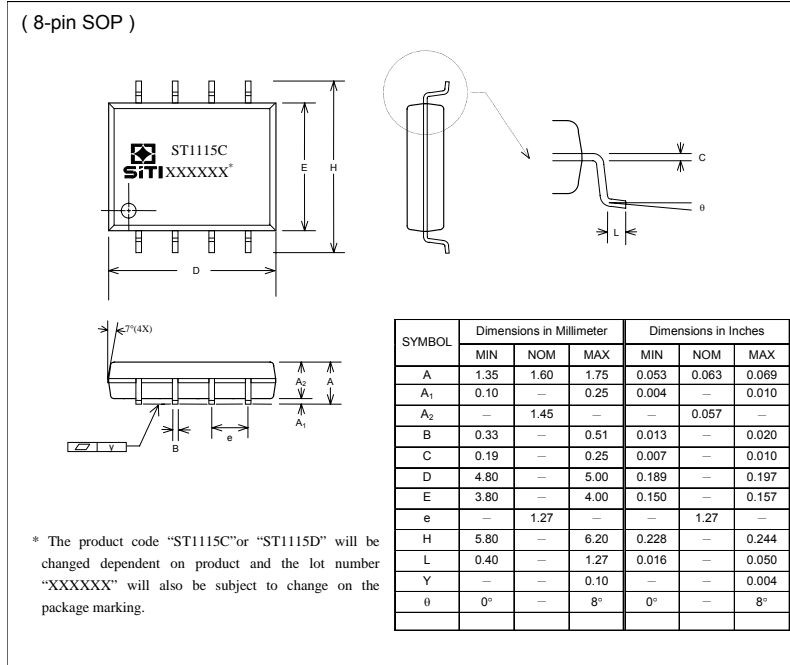

MSOP8 : ST1115C_TMS1 / ST1115D_TMS1

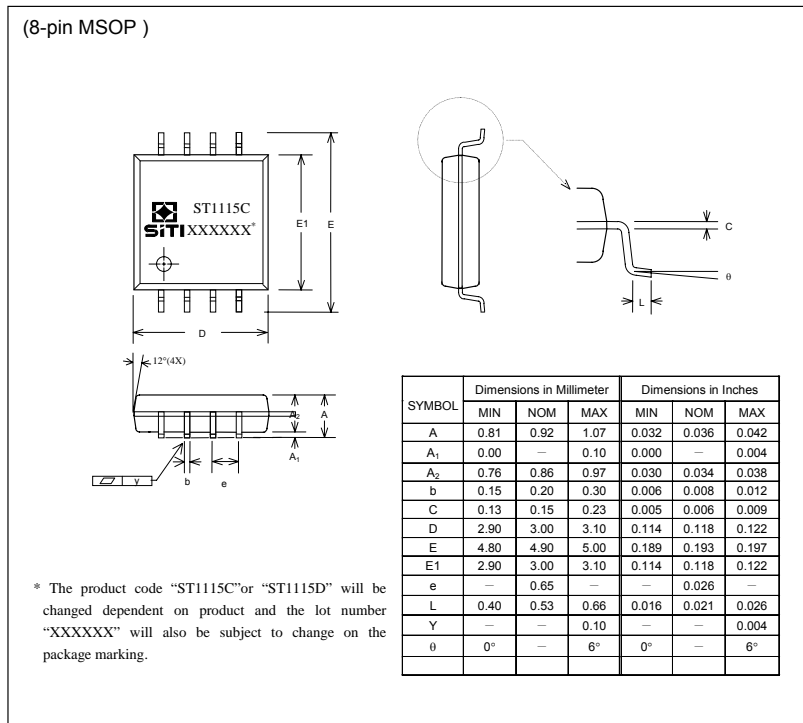



The products listed herein are designed for ordinary electronic applications, such as electrical appliances, audio-visual equipments, communication devices and so on. Hence, it is advisable that the devices should not be used in medical instruments, surgical implants, aerospace machinery, nuclear power control systems, disaster/crime-prevention equipments and the like. Misusing those products may directly or indirectly endanger human life, or cause injury and property loss.

Silicon Touch Technology, Inc. will not take any responsibilities regarding the misuse of the products mentioned above. Anyone who purchases any products described herein with the above-mentioned intention or with such misused applications should accept full responsibility and indemnify. Silicon Touch Technology, Inc. and its distributors and all their officers and employees shall defend jointly and severally against any and all claims and litigation and all damages, cost and expenses associated with such intention and manipulation.