

# SZ153D - SZ15D0

# SURFACE MOUNT SILICON ZENER DIODES

**V<sub>Z</sub> : 3.3 - 200 Volts**  
**P<sub>D</sub> : 1 Watt**

### FEATURES :

- \* Complete Voltage Range 3.3 to 200 Volts
- \* High peak reverse power dissipation
- \* High reliability
- \* Low leakage current
- \* **Pb / RoHS Free**

### MECHANICAL DATA

- \* Case : SMA (DO-214AC) Molded plastic
- \* Epoxy : UL94V-O rate flame retardant
- \* Lead : Lead formed for Surface mount
- \* Polarity : Color band denotes cathode end
- \* Mounting position : Any
- \* Weight : 0.064 gram

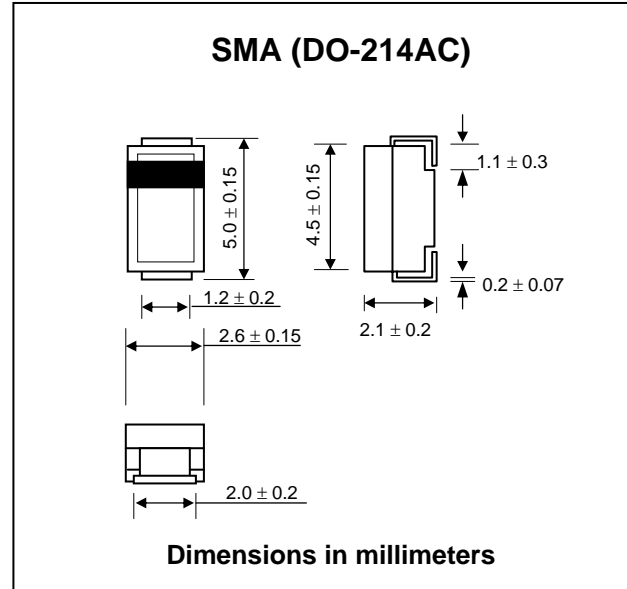

### MAXIMUM RATINGS

Rating at 25 °C ambient temperature unless otherwise specified

Rating	Symbol	Value	Unit
DC Power Dissipation at T <sub>L</sub> = 75 °C (Note1)	P <sub>D</sub>	1.0	W
Maximum Forward Voltage at I <sub>F</sub> = 200 mA	V <sub>F</sub>	1.2	V
Junction Temperature Range	T <sub>J</sub>	- 55 to + 150	°C
Storage Temperature Range	T <sub>s</sub>	- 55 to + 150	°C

#### Note :

(1) P.C.B. Mounted on 0.31x0.31x0.08" (8x8x2mm) copper areas pads.

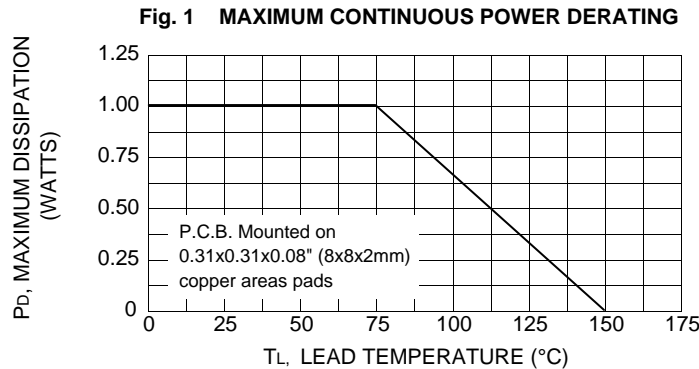

## ELECTRICAL CHARACTERISTICS

Rating at 25 °C ambient temperature unless otherwise specified

Type	Nominal Zener Voltage		Maximum Zener Impedance			Maximum Reverse Leakage Current		Maximum DC Zener Current	Maximum Surge Current
	$V_Z^{(1)}$ @ I <sub>ZT</sub>	I <sub>ZT</sub>	Z <sub>ZT</sub> @ I <sub>ZT</sub>	Z <sub>ZK</sub> @ I <sub>ZK</sub>	I <sub>ZK</sub>	I <sub>R</sub> @ V <sub>R</sub>		I <sub>ZM</sub>	I <sub>RM</sub> <sup>(2)</sup>
	(V)	(mA)	(Ω)	(Ω)	(mA)	(μA)	(V)	(mA)	(mApk)
SZ153D	3.3	76.0	10	400	1.0	100	1.0	276	1380
SZ153G	3.6	69.0	10	400	1.0	100	1.0	252	1260
SZ153J	3.9	64.0	9.0	400	1.0	50	1.0	234	1190
SZ154D	4.3	58.0	9.0	400	1.0	10	1.0	217	1070
SZ154H	4.7	53.0	8.0	500	1.0	10	1.0	193	970
SZ155B	5.1	49.0	7.0	550	1.0	10	1.0	178	890
SZ155G	5.6	45.0	5.0	600	1.0	10	2.0	162	810
SZ156C	6.2	41.0	2.0	700	1.0	10	3.0	146	730
SZ156I	6.8	37.0	3.5	700	1.0	10	4.0	133	660
SZ157F	7.5	34.0	4.0	700	0.5	10	5.0	121	605
SZ158C	8.2	31.0	4.5	700	0.5	10	6.0	110	550
SZ159B	9.1	28.0	5.0	700	0.5	10	7.0	100	500
SZ1510	10	25.0	7.0	700	0.25	10	7.6	91	454
SZ1511	11	23.0	8.0	700	0.25	5.0	8.4	83	414
SZ1512	12	21.0	9.0	700	0.25	5.0	9.1	76	380
SZ1513	13	19.0	10	700	0.25	5.0	9.9	69	344
SZ1515	15	17.0	14	700	0.25	5.0	11.4	61	305
SZ1516	16	15.5	16	700	0.25	5.0	12.2	57	285
SZ1518	18	14.0	20	750	0.25	5.0	13.7	50	250
SZ1520	20	12.5	22	750	0.25	5.0	15.2	45	225
SZ1522	22	11.5	23	750	0.25	5.0	16.7	41	205
SZ1524	24	10.5	25	750	0.25	5.0	18.2	38	190
SZ1527	27	9.5	35	750	0.25	5.0	20.6	34	170
SZ1530	30	8.5	40	1000	0.25	5.0	22.8	30	150
SZ1533	33	7.5	45	1000	0.25	5.0	25.1	27	135
SZ1536	36	7.0	50	1000	0.25	5.0	27.4	25	125
SZ1539	39	6.5	60	1000	0.25	5.0	29.7	23	115
SZ1543	43	6.0	70	1500	0.25	5.0	32.7	22	110
SZ1547	47	5.5	80	1500	0.25	5.0	35.8	19	95
SZ1551	51	5.0	95	1500	0.25	5.0	38.8	18	90
SZ1556	56	4.5	110	2000	0.25	5.0	42.6	16	80
SZ1562	62	4.0	125	2000	0.25	5.0	47.1	14	70
SZ1568	68	3.7	150	2000	0.25	5.0	51.7	13	65
SZ1575	75	3.3	175	2000	0.25	5.0	56.0	12	60
SZ1582	82	3.0	200	3000	0.25	5.0	62.2	11	55
SZ1591	91	2.8	250	3000	0.25	5.0	69.2	10	50
SZ15B0	100	2.5	350	3000	0.25	5.0	76.0	9.0	45
SZ15B1	110	2.3	450	4000	0.25	5.0	83.6	8.6	40
SZ15B2	120	2.0	550	4500	0.25	5.0	91.2	7.8	37
SZ15B3	130	1.9	700	5000	0.25	5.0	98.8	7.0	34
SZ15B5	150	1.7	1000	6000	0.25	5.0	114.0	6.4	30
SZ15B6	160	1.6	1100	6500	0.25	5.0	121.6	5.8	28
SZ15B8	180	1.4	1200	7000	0.25	5.0	136.8	5.2	25
SZ15D0	200	1.2	1900	9990	0.25	5.0	152.0	4.7	22

### Notes :

- (1) The type number listed have a standard tolerance on the nominal zener voltage of ±5%, altered the fourth number of type from " 5 " for ±5% tolerance to be " 0 " for ±10% tolerance.
- (2) The reverse surge current is a non-repetitive, 8.3ms pulse width square wave or equivalent sine-wave superimposed on I<sub>ZT</sub> per JEDEC Method
- (3) " SZ " will be omitted in marking on the diode.