

#### INTRODUCTION:

Adam Tech RT2 relays are small signal level relays whose footprint matches a standard 16 pin DIP socket and are available with coil voltages from 5~48VDC. These 2 form C relays are designed for all signal applications up to 2 amps, such as security equipment, test equipment and medical equipment

#### FEATURES:

High sensitivity: 200 mW nominal operating power.  
2 Amp switching capability  
Power consumption of 200mW  
High mounting density on P.C.board by small size and light weight.  
Sealed construction.

#### SPECIFICATIONS:

##### ELECTRICAL:

Contact arrangement: 2 Form C  
Contact material: Gold clad, Silver Alloy  
Contact Rating (Resistive load): 1A @ 120V AC  
2A @ 30V DC  
Max. Switching Voltage: 120V AC / 30V DC  
Max. Switching Power: 100VA / 60W  
Contact resistance: 100 mΩ max. Initial  
Insulation resistance: 100 MΩ min. @ 500V DC  
Dielectric withstanding voltage:  
Between Coil & Contact: 500V AC 50/60Hz for 1 min.  
Between Contacts: 1000V AC 50/60Hz for 1 min.  
Operating time: 6 ms max.  
Release time: 4 ms max.  
Electrical Life: 100,000 Operations (at rated load)

##### MECHANICAL:

Vibration resistance (Endurance): 1.5mm Double Amplitude 10-55Hz  
Shock resistance: 10G min.  
Mechanical Life: 10,000,000 Operations (no load)

##### TEMPERATURE RATING:

Ambient temperature: -40°C to +85°C

##### PACKAGING:

Anti-ESD plastic tubes  
Tape & Reel

##### SAFETY AGENCY APPROVALS:

cUL Recognized File No. E305638

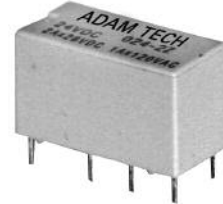

#### ORDERING INFORMATION SIGNAL RELAY

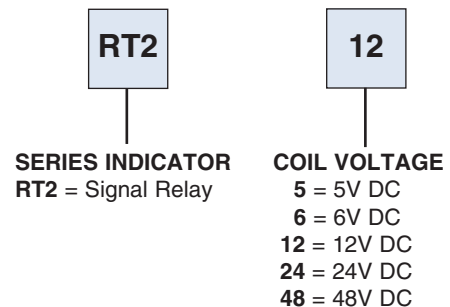

#### RT2 SERIES

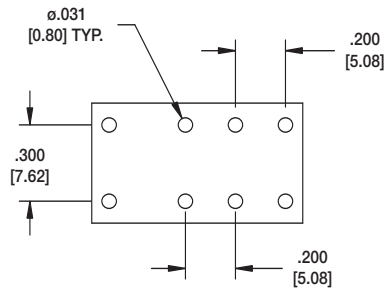
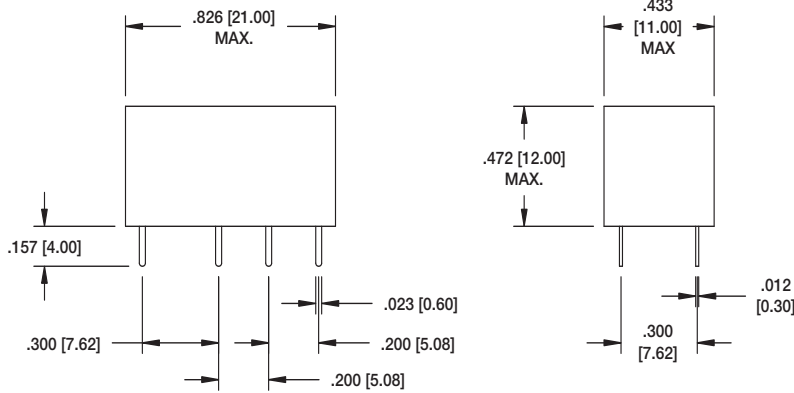

Recommended PCB Layout

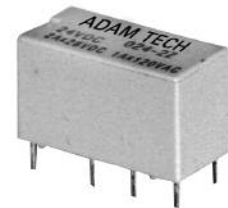

RT2-24

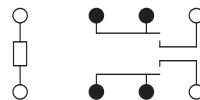

Schematic

Nominal Voltage V DC	Pick-up Voltage V DC (max.)	Drop-out Voltage V DC (min.)	Nominal Operating Current mA ( $\pm 10\%$ )	Coil Resistance ( $\pm 10\%$ )	Nominal Operating Power mW	Max allowable Voltage V DC
5	3.5	0.5	40	125	200	10
6	4.2	0.6	33.3	180	200	12
12	8.4	1.2	16.7	720	200	24
24	16.8	2.4	8.3	2,880	200	48
48	33.6	4.8	6.3	7,680	300	86