

# ST1152A

---

*Version* : A.006  
*Issue Date* : 2005/10/25  
*File Name* : SP-ST1152A-A.006.doc  
*Total Pages* : 7

*Low-saturation, Low-voltage  
Bi-directional Motor Driver*



**SITI**

SILICON TOUCH TECHNOLOGY INC.

新竹市科學園區展業一路九號四樓之三

9-4F-3 Prosperity Road I Science-Based Industrial Park

Hsinchu, Taiwan 300, R.O.C.

Tel : 886-3-5645656 Fax : 886-3-5645626

---

---

## ST1152A

# Low-saturation, Low-voltage Bi-directional Motor Driver

## General Specifications

The device is a two-channel low-saturation bi-directional motor driver IC. The design is optimal for stepper-motor applications, such as cameras, printers, FDDs, or other portable devices.

## Features and Benefits

- Low voltage operation (  $V_{DD\ min} = V_{S1\ min} = V_{S2\ min} = 1.5V$  )
- Low saturation voltage ( Upper transistor + low transistor residual voltage; 0.3V typ. at 400mA, 0.6V typ. at 750mA)
- Parallel connection ( two-channel driver: Upper transistor + low transistor residual ; 0.4V typ. at 800mA )
- Separate control logic power supply and motor driver power supply
- Brake function
- High output sinking and driving capability
- Thin, highly reliable package (SOP-14)

## Pin Assignment

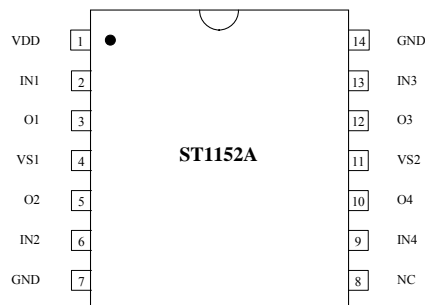



PIN NO.	PIN NAME	DESCRIPTION
1	VDD	Power supply pin for controller.
2	IN1	Input pin that determines driving mode.
3	O1	Output sinking / driving pin.
4	VS1	Power supply pin for output driver O1/ O2.
5	O2	Output sinking / driving pin.
6	IN2	Input pin that determines driving mode.
7	GND	Ground pin
8	NC	No connecting
9	IN4	Input pin that determines driving mode.
10	O4	Output sinking / driving pin.
11	VS2	Power supply pin for output driver O3/ O4.
12	O3	Output sinking / driving pin.
13	IN3	Input pin that determines driving mode.
14	GND	Ground pin

**Absolute Maximum Ratings** ( Unless otherwise noted,  $T_A=25^{\circ}\text{C}$  )

Characteristic	Symbol	Rating	Unit
Supply Voltage	$V_{DD}$	5.5	V
	$V_S$	5.5	V
Input Voltage	$V_{IN}$	$V_{DD}+0.4$	V
$I_O$ Peak Current (in parallel connection)	$I_{OPeak}$	3	A
$I_{ODC}$ Current (in parallel connection)	$I_{ODC}$	1.5	A
Power Dissipation	$P_D$	800	mW
Operating Temperature Range	$T_{OPR}$	-40 ~ 125	$^{\circ}\text{C}$
Storage Temperature Range	$T_{STG}$	-65 ~ 150	$^{\circ}\text{C}$

## Electrical Characteristic

(Unless otherwise noted,  $T_A = 25^\circ\text{C}$  &  $V_{DD} = V_S = 3\text{V}$ )

Characteristic	Sym.	Condition	Limit			Unit
			Min.	Typ.	Max.	
Supply Voltage	$V_{DD}$		1.5	3	5.5	V
	$V_S$		1.5	3	5.5	V
Supply Current ( $I_{DD} + I_S$ )	$I_{DD0}$	$V_{IN1, IN2, IN3, IN4} = 0\text{V}$		0.1	10	$\mu\text{A}$
	$I_{DD1}$	$V_{IN1}=3\text{V}, V_{IN2, IN3, IN4}=0\text{V}$		0.05	0.5	mA
	$I_{DD2}$	$V_{IN1, IN2}=3\text{V}, V_{IN3, IN4}=0\text{V}$		0.1	10	$\mu\text{A}$
IN1 / IN2 / IN3 / IN4 Input Terminal ( $T_J = 25^\circ\text{C}$ )						
Input Voltage "H"	$V_{IH}$	-	$0.8 \cdot V_{DD}$	-	$V_{DD} + 0.4$	V
Input Voltage "L"	$V_{IL}$	-	-0.4	-	$0.2 \cdot V_{DD}$	V
Input Current "H"	$I_{IH}$	$V_{IN} = V_{DD}$	-	-	$\pm 5$	$\mu\text{A}$
Input Current "L"	$I_{IL}$	$V_{IN} = 0\text{V}$	-	-	$\pm 5$	$\mu\text{A}$
O1 / O2 / O3 / O4 Output Terminal ( $T_J = 25^\circ\text{C}$ )						
Output Voltage (upper + lower)	$V_{OUT1}$	$I_{OUT} = 200\text{ mA}$	-	0.15	0.3	V
	$V_{OUT2}$	$I_{OUT} = 400\text{ mA}$	-	0.3	0.6	V
	$V_{OUT3}$	$I_{OUT} = 750\text{ mA}$	-	0.6	0.95	V
	$V_{OUT4}$	$I_{OUT} = 400\text{ mA}$ (parallel connection)	-	0.2	0.35	V
	$V_{OUT5}$	$I_{OUT} = 800\text{ mA}$ (parallel connection)	-	0.4	0.7	V
Output Resistance	$R_{on}$	$V_{DD}=V_S=3\text{V}, I_{OUT}=400\text{ mA}$	-	0.75	-	$\Omega$
Output Sustaining Voltage	$V_{O(SUS)}$	$I_{OUT} = 400\text{ mA}$	-	-	$V_S$	V

## Truth Table

IN1 / IN3	IN2 / IN4	O1 / O3	O2 / O4	Mode
H	L	H	L	Forward
L	H	L	H	Reverse
H	H	H	H	Brake
L	L	OFF	OFF	Standby

## Block Diagram & Application Circuit

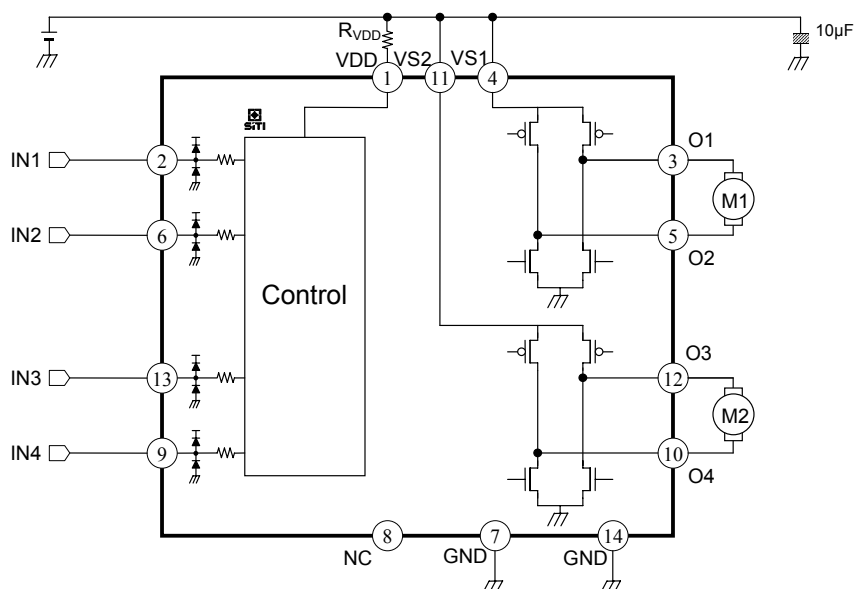

## Application Notes

- To increase system stability, it is suggestion to connect a resistor  $R_{VDD}$  about  $470\Omega$  between battery power and driver's VDD pin as shown on application circuit.
- In multiple power supply application, although power supply of control logic (VDD) and motor driver (VS1, VS2) are separated for noise reduction, the voltage of VDD, VS1 and VS2 pins can be expressed by  $V(VDD) - 0.5 \geq V(VS)$ , where  $V(VDD)$  is the voltage of VDD pin and  $V(VS)$  is the voltage of VS1 and VS2 pins.
- The power dissipated by the IC varies widely with the supply voltage, the output current, and loading. It is important to ensure the application does not exceed the allowable power dissipation of the IC package. The recommended motor driver power dissipation versus temperature is depicted as follows:

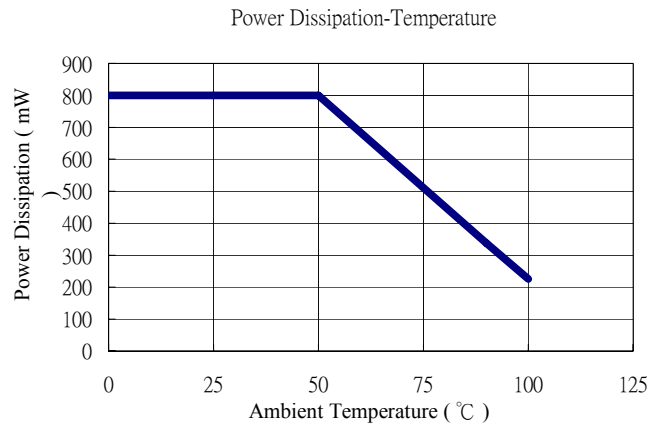

## Package Specifications(SOP-14)

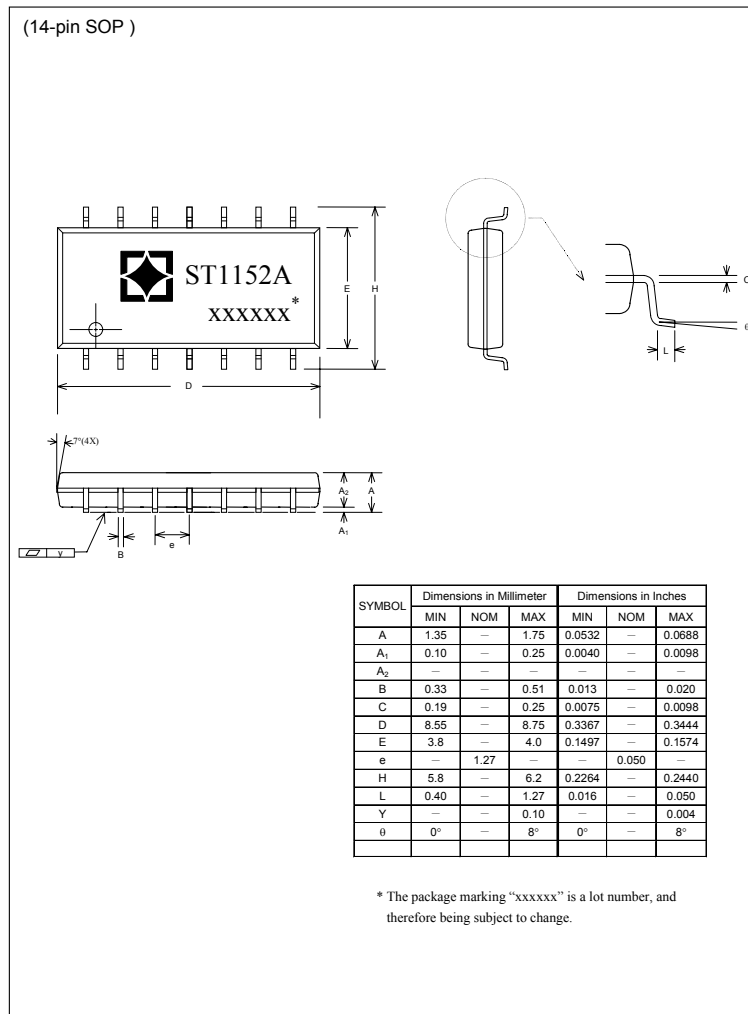

The products listed herein are designed for ordinary electronic applications, such as electrical appliances, audio-visual equipment, communications devices and so on. Hence, it is advisable that the devices should not be used in medical instruments, surgical implants, aerospace machinery, nuclear power control systems, disaster/crime-prevention equipment and the like. Misusing those products may directly or indirectly endanger human life, or cause injury and property loss.

Silicon Touch Technology, Inc. will not take any responsibilities regarding the misuse of the products mentioned above. Anyone who purchases any products described herein with the above-mentioned intention or with such misused applications should accept full responsibility and indemnify. Silicon Touch Technology, Inc. and its distributors and all their officers and employees shall defend jointly and severally against any and all claims and litigation and all damages, cost and expenses associated with such intention and manipulation.