

# 16-bit Proprietary Microcontroller

CMOS

## F<sup>2</sup>MC-16L MB90670/675 Series

### MB90671/672/673/T673/P673 (MB90670 Series) MB90676/677/678/T678/P678 (MB90675 Series)

#### ■ DESCRIPTION

The MB90670/675 series is a member of 16-bit proprietary single-chip microcontroller F<sup>2</sup>MC\*1-16L family designed to be combined with an ASIC (Application Specific IC) core. The MB90670/675 series is a high-performance general-purpose 16-bit microcontroller for high-speed real-time processing in various industrial equipment, OA equipment, and process control.

The instruction set of F<sup>2</sup>MC-16L CPU core inherits AT architecture of F<sup>2</sup>MC-8 family with additional instruction sets for high-level languages, extended addressing mode, enhanced multiplication/division instructions, and enhanced bit manipulation instructions. The microcontroller has a 32-bit accumulator for processing long word data (32-bit).

The MB90670/675 series has peripheral resources of UART0, UART1(SCI), an 8/10-bit A/D converter, an 8/16-bit PPG timer, a 16-bit reload timer, a 24-bit free run timer, an output compare (OCU), an input capture (ICU), DTP/external interrupt circuit, an I<sup>2</sup>C\*2 interface (in MB90675 series only). Embedded peripheral resources performs data transmission with an intelligent I/O service function without the intervention of the CPU, enabling real-time control in various applications.

\*1: F<sup>2</sup>MC stands for FUJITSU Flexible Microcontroller.

\*2: Purchase of Fujitsu I<sup>2</sup>C components conveys a license under the Philips I<sup>2</sup>C Patent Rights to use these components in an I<sup>2</sup>C system, provided that the system conforms to the I<sup>2</sup>C Standard Specification as defined by Philips.

#### ■ PACKAGES

80-pin Plastic LQFP

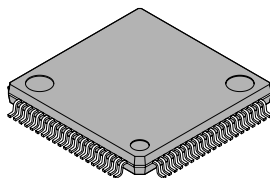

(FPT-80P-M05)

80-pin Plastic QFP

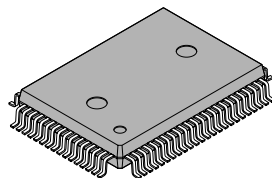

(FPT-80P-M06)

100-pin Plastic LQFP

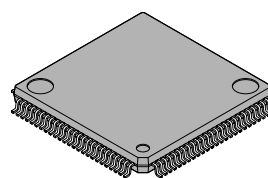

(FPT-100P-M05)

100-pin Plastic QFP

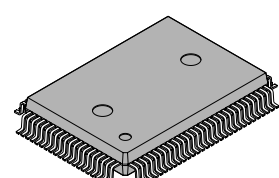

(FPT-100P-M06)

# MB90670/675 Series

## ■ FEATURES

- Clock
  - Embedded PLL clock multiplication circuit
  - Operating clock (PLL clock) can be selected from divided-by-2 of oscillation or one to four times the oscillation (at oscillation of 4 MHz, 4 MHz to 16 MHz).
  - Minimum instruction execution time of 62.5 ns (at oscillation of 4 MHz, four times the PLL clock, operation at V<sub>cc</sub> of 5.0 V)
- CPU addressing space of 16 Mbytes
  - Internal addressing of 24-bit
  - External accessing can be performed by selecting 8/16-bit bus width (external bus mode)
- Instruction set optimized for controller applications
  - Rich data types (bit, byte, word, long word)
  - Rich addressing mode (23 types)
  - High code efficiency
  - Enhanced precision calculation realized by the 32-bit accumulator
- Instruction set designed for high level language (C) and multi-task operations
  - Adoption of system stack pointer
  - Enhanced pointer indirect instructions
  - Barrel shift instructions
- Enhanced execution speed
  - 4-byte instruction queue
- Enhanced interrupt function
  - 8 levels, 32 factors
- Automatic data transmission function independent of CPU operation
  - Extended intelligent I/O service function (EI<sup>2</sup>OS)
- Low-power consumption (standby) mode
  - Sleep mode (mode in which CPU operating clock is stopped)
  - Timebase timer mode (mode in which other than oscillation and timebase timer are stopped)
  - Stop mode (mode in which oscillation is stopped)
  - CPU intermittent operation mode
  - Hardware standby mode
- Process
  - CMOS technology
- I/O port
  - MB90670 series: Maximum of 65 ports
  - MB90675 series: Maximum of 84 ports
- Timer
  - Timebase timer/watchdog timer: 1 channel
  - 8/16-bit PPG timer: 8-bit × 2 channels or 16-bit × 1 channel
  - 16-bit reload timer: 2 channels
  - 24-bit free run timer: 1 channel
- Input capture (ICU)
  - Generates an interrupt request by latching a 24-bit free run timer counter value upon detection of an edge input to the pin.
- Output compare (OCU)
  - Generates an interrupt request and reverse the output level upon detection of a match between the 24-bit free run timer counter value and the compare setting value.
- I<sup>2</sup>C interface (in MB90675 series only)
- Serial I/O port for supporting Inter IC BUS

(Continued)

www.DataSheet4U.com

*(Continued)*

- UART0

With full-duplex double buffer (8-bit length)

Clock asynchronous or clock synchronized transmission (with start and stop bits) can be selectively used.

- UART1 (SCI)

With full-duplex double buffer (8-bit length)

Clock asynchronous or clock synchronized serial transmission (I/O extended serial) can be selectively used.

- DTP/external interrupt circuit (4 channels)

A module for starting extended intelligent I/O service (EI<sup>2</sup>OS) and generating an external interrupt triggered by an external input.

- Wake-up interrupt

Receives external interrupt requests and generates an interrupt request upon an "L" level input.

- Delayed interrupt generation module

Generates an interrupt request for switching tasks.

- 8/10-bit A/D converter (8 channels)

8-bit or 10-bit resolution can be selectively used.

Starting by an external trigger input.

# MB90670/675 Series

## ■ PRODUCT LINEUP

- MB90670 series

Item \ Part number	MB90671	MB90672	MB90673	MB90T673	MB90P673
Classification	Mask ROM products			External ROM product	One-time PROM product
ROM size	16 Kbytes	32 Kbytes	48 Kbytes	External ROM	48 Kbytes
RAM size	640 bytes	1.64 Kbytes	2 Kbytes		
CPU functions	Number of instructions: 340 Instruction bit length: 8 bits, 16 bits Instruction length: 1 byte to 7 bytes Data bit length: 1 bit, 8 bits, 16 bits Minimum execution time: 62.5 ns (at machine clock of 16 MHz) Interrupt processing time: 1.5 $\mu$ s (at machine clock of 16 MHz, minimum value)				
Ports	General-purpose I/O ports (CMOS output): 57 General-purpose I/O ports (N-ch open-drain output): 8 Total: 65				
UART0	Clock synchronized transmission (500 Kbps to 2 Mbps) Clock asynchronized transmission (4800 Kbps to 500 Kbps) Transmission can be performed by bi-directional serial transmission or by master/slave connection.				
UART1 (SCI)	Clock synchronized transmission (500 Kbps to 2 Mbps) Clock asynchronized transmission (2400 Kbps to 62500 bps) Transmission can be performed by bi-directional serial transmission or by master/slave connection.				
8/10-bit A/D converter	Conversion precision: 10-bit or 8-bit selectable Number of inputs: 8 One-shot conversion mode (converts selected channel only once) Continuous conversion mode (converts selected channel continuously) Stop conversion mode (converts selected channel and stop operation repeatedly)				
8/16-bit PPG timer	Number of channels: 2 8-bit or 16-bit PPG operation A Pulse wave of given intervals and given duty ratios can be output. Pulse cycle: 125 ns to 16.78 s (at oscillation of 4 MHz, machine clock of 16 MHz)				
16-bit reload timer	Number of channels: 2 16-bit reload timer operation Interval: 125 ns to 131 ms (at machine clock of 16 MHz) External event count can be performed.				
24-bit free run timer	Number of channel :1 Overflow interrupts or intermediate bit interrupts may be generated.				
Output compare unit (OCU)	Number of channels: 8 Pin input factor: A match signal of compare register				

(Continued)

# MB90670/675 Series

(Continued)

Part number	MB90671	MB90672	MB90673	MB90T673	MB90P673
Input capture unit (ICU)	Number of channels: 4 Rewriting a register value upon a pin input (rising, falling, or both edges)				
DTP/external interrupt circuit	Number of inputs: 4 Started by a rising edge, a falling edge, an "H" level input, or an "L" level input. External interrupt circuit or extended intelligent I/O service (EI <sup>2</sup> OS) can be used.				
Wake-up interrupt	Number of inputs: 8 Started by an "L" level input.				
Delayed interrupt generation module	An interrupt generation module for switching tasks used in real-time operating systems.				
I <sup>2</sup> C interface	None				
Timebase timer	18-bit counter Interrupt interval: 1.024 ms, 4.096 ms, 16.384 ms, 131.072 ms (at oscillation of 4 MHz)				
Watchdog timer	Reset generation interval: 3.58 ms, 14.33 ms, 57.23 ms, 458.75 ms (at oscillation of 4 MHz, minimum value)				
Low-power consumption (standby) mode	Sleep/stop/CPU intermittent operation/timebase timer/hardware stand-by				
Process	CMOS				
Operating voltage*	2.7 V to 5.5 V				

\*: Varies with conditions such as the operating frequency. (See section "■ Electrical Characteristics.")

# MB90670/675 Series

• MB90675 series

Part number Item	MB90676	MB90677	MB90678	MB90T678	MB90P678	MB90V670
Classification	Mask ROM products			External ROM product	One-time PROM product	Evaluation product
ROM size	32 Kbytes	48 Kbytes	64 Kbytes	None	64 Kbytes	—
RAM size	1.64 Kbytes	2 Kbytes	3 Kbytes		4 Kbytes	
CPU functions	The number of instructions: 340 Instruction bit length: 8 bits, 16 bits Instruction length: 1 byte to 7 bytes Data bit length: 1 bit, 8 bits, 16 bits Minimum execution time: 62.5 ns (at machine clock of 16 MHz) Interrupt processing time: 1.5 $\mu$ s (at machine clock of 16 MHz, minimum value)					
Ports	General-purpose I/O ports (CMOS output): 74 General-purpose I/O ports (N-ch open-drain output): 10 Total: 84					
UART0	Clock synchronized transmission (500 Kbps to 2 Mbps) Clock asynchronized transmission (4800 Kbps to 500 Kbps) Transmission can be performed by bi-directional serial transmission or by master/slave connection.					
UART1 (SCI)	Clock synchronized transmission (500 Kbps to 2 Mbps) Clock asynchronized transmission (2400 Kbps to 62500 bps) Transmission can be performed by bi-directional serial transmission or by master/slave connection.					
8/10-bit A/D converter	Conversion precision: 10-bit or 8-bit can be selectively used. Number of inputs: 8 One-shot conversion mode (converts selected channel only once) Continuous conversion mode (converts selected channel continuously) Stop conversion mode (converts selected channel and stop operation repeatedly)					
8/16-bit PPG timer	Number of channels: 2 PPG operation of 8-bit or 16-bit Pulse of given intervals and given duty ratios can be output Pulse interval 125 ns to 16.78 s (at oscillation of 4 MHz, machine clock of 16 MHz)					
16-bit reload timer	Number of channels: 2 16-bit reload timer operation Interval: 125 ns to 131 ms (at machine clock of 16 MHz) External event count can be performed.					
24-bit free run timer	Number of channel :1 Overflow interrupts or intermediate bit interrupts may be generated.					
Output compare (OCU)	Number of channels: 8 Pin input factor: a match signal of compare register					

(Continued)

# MB90670/675 Series

(Continued)

Part number Item	MB90676	MB90677	MB90678	MB90T678	MB90P678	MB90V670
Input capture (ICU)	Number of channels: 4 Rewriting a register value upon a pin input (rising, falling, or both edges)					
DTP/external interrupt circuit	Number of inputs: 4 Started by a rising edge, a falling edge, an "H" level input, or an "L" level input. External interrupt circuit or extended intelligent I/O service (EI <sup>2</sup> OS) can be used.					
Wake-up interrupt	Number of inputs: 8 Started by an "L" level input.					
Delayed interrupt generation module	An interrupt generation module for switching tasks used in realtime operating systems.					
I <sup>2</sup> C interface	Serial I/O port for supporting Inter IC BUS					
Timebase timer	18-bit counter Interrupt interval: 1.024 ms, 4.096 ms, 16.384 ms, 131.072 ms (at oscillation of 4 MHz)					
Watchdog timer	Reset generation interval: 3.58 ms, 14.33 ms, 57.23 ms, 458.75 ms (at oscillation of 4 MHz, minimum value)					
Low-power consumption (stand-by) mode	Sleep/stop/CPU intermittent operation/timebase timer/hardware stand-by					
Process	CMOS					
Power supply voltage for operation*	2.7 V to 5.5 V					

\*: Varies with conditions such as the operating frequency. (See section "■ ELECTRICAL CHARACTERISTICS.")  
Assurance for the MB90V670 is given only for operation with a tool at a power voltage of 2.7 V to 5.5 V, an operating temperature of 0°C to 70°C, and an operating frequency of 1.5 MHz to 16 MHz.

## ■ PACKAGE AND CORRESPONDING PRODUCTS

Package	MB90671 MB90672 MB90673 MB90T673	MB90P673	MB90676 MB90677 MB90678 MB90T678	MB90P678	MB90V670
FPT-80P-M05	○	○	×	×	×
FPT-80P-M06	○	○	×	×	×
FPT-100P-M05	×	×	○	○	×
FPT-100P-M06	×	×	○	○	×

○ : Available    × : Not available

Note: For more information about each package, see section "■ PACKAGE DIMENSIONS."

# MB90670/675 Series

## ■ DIFFERENCES AMONG PRODUCTS

### 1. Memory Size

In evaluation with an evaluation product, note the difference between the evaluation chip and the chip actually used. The following items must be taken into consideration.

- The MB90V670 does not have an internal ROM, however, operations equivalent to chips with an internal ROM can be evaluated by using a dedicated development tool, enabling selection of ROM size by settings of the development tool.
- In the MB90V670, images from FF4400<sub>H</sub> to FFFFFFF<sub>H</sub> are mapped to bank 00, and FE0000<sub>H</sub> to FF3FFF<sub>H</sub> to mapped to bank FE<sub>H</sub> and FF<sub>H</sub> only. (This setting can be changed by configuring the development tool.)
- In the MB90678/MB90P678, images from FF4000<sub>H</sub> to FFFFFFF<sub>H</sub> are mapped to bank 00, and FF0000<sub>H</sub> to FF3FFF<sub>H</sub> to bank FF only.

### 2. Mask Options

Functions selected by optional settings and methods for setting the options are dependent on the product types.

Refer to “■ Mask Options” for detailed information.

Note that mask option is fixed in MB90V670 series.



# MB90670/675 Series

## PIN ASSIGNMENTS

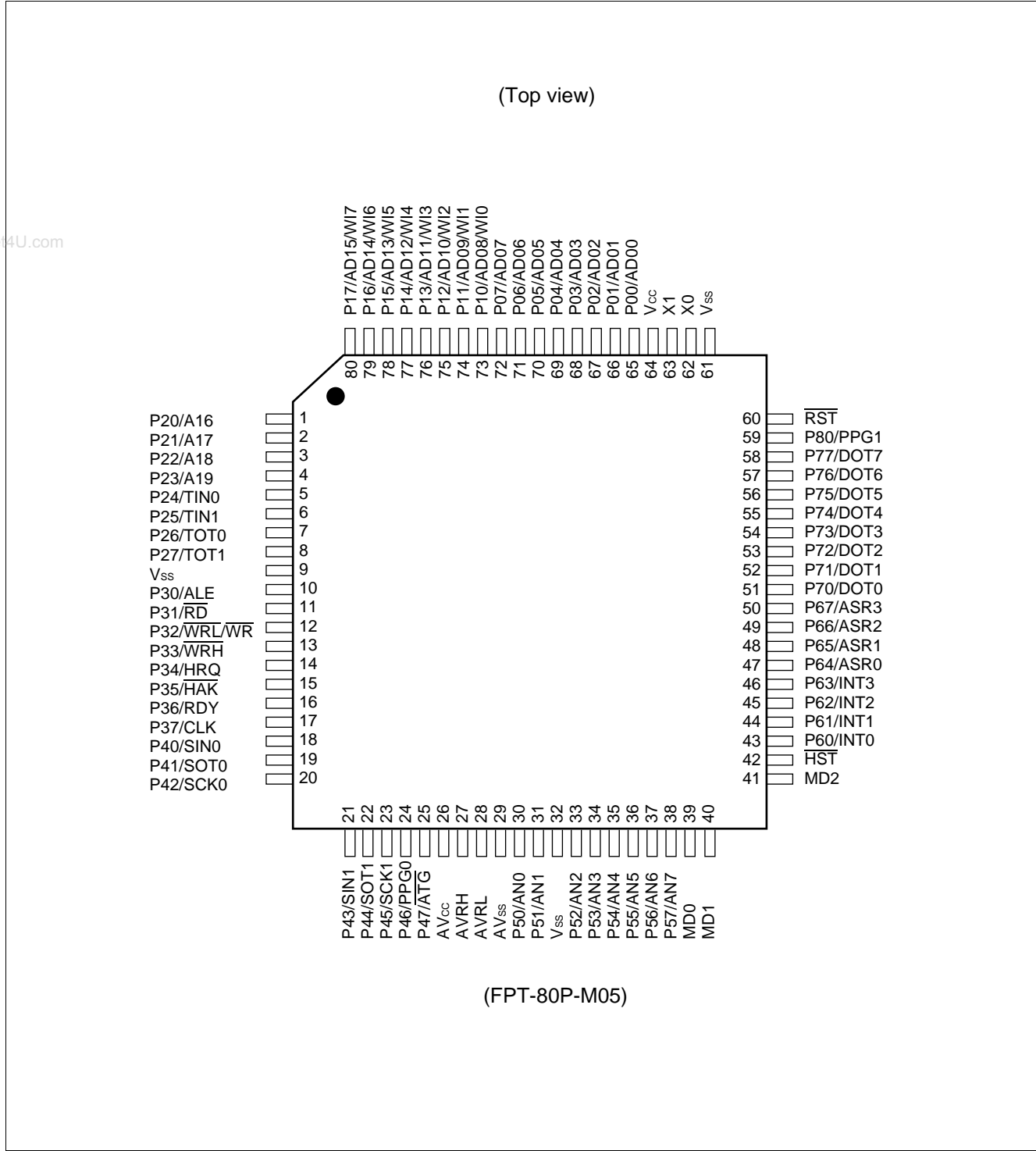

(Continued)

# MB90670/675 Series

(Top view)

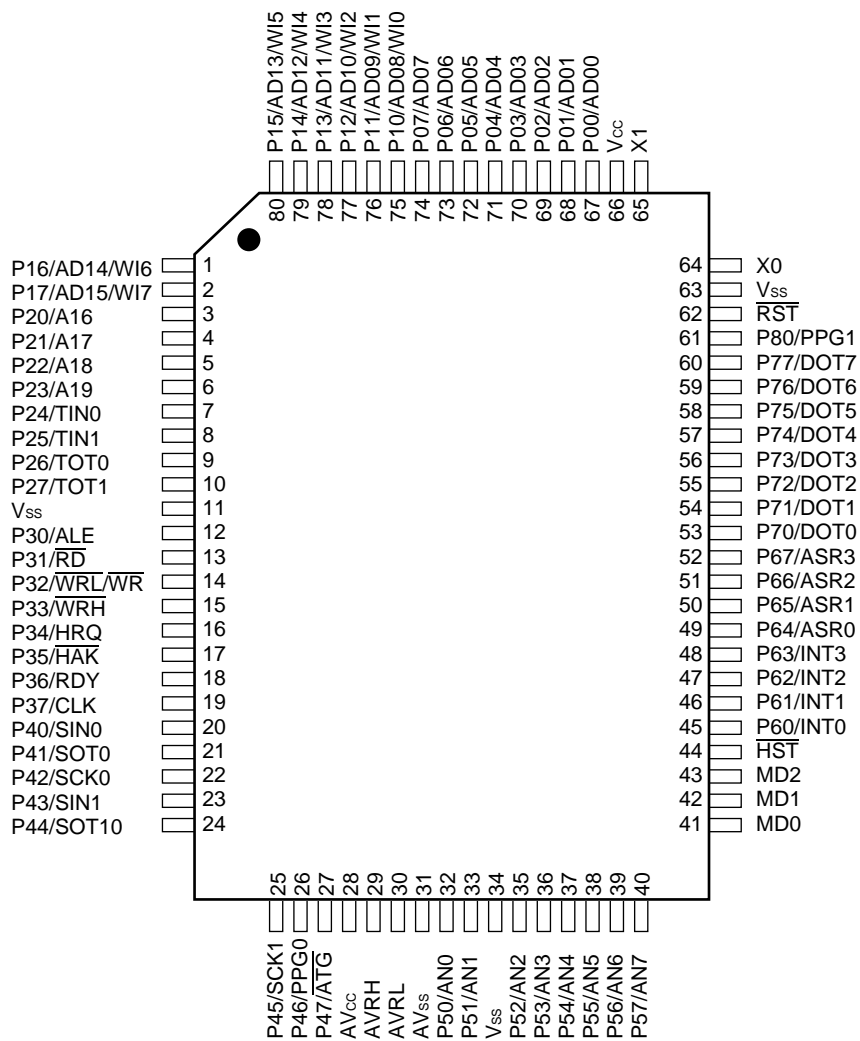

(FPT-80P-M06)

(Continued)

# MB90670/675 Series

(Top view)

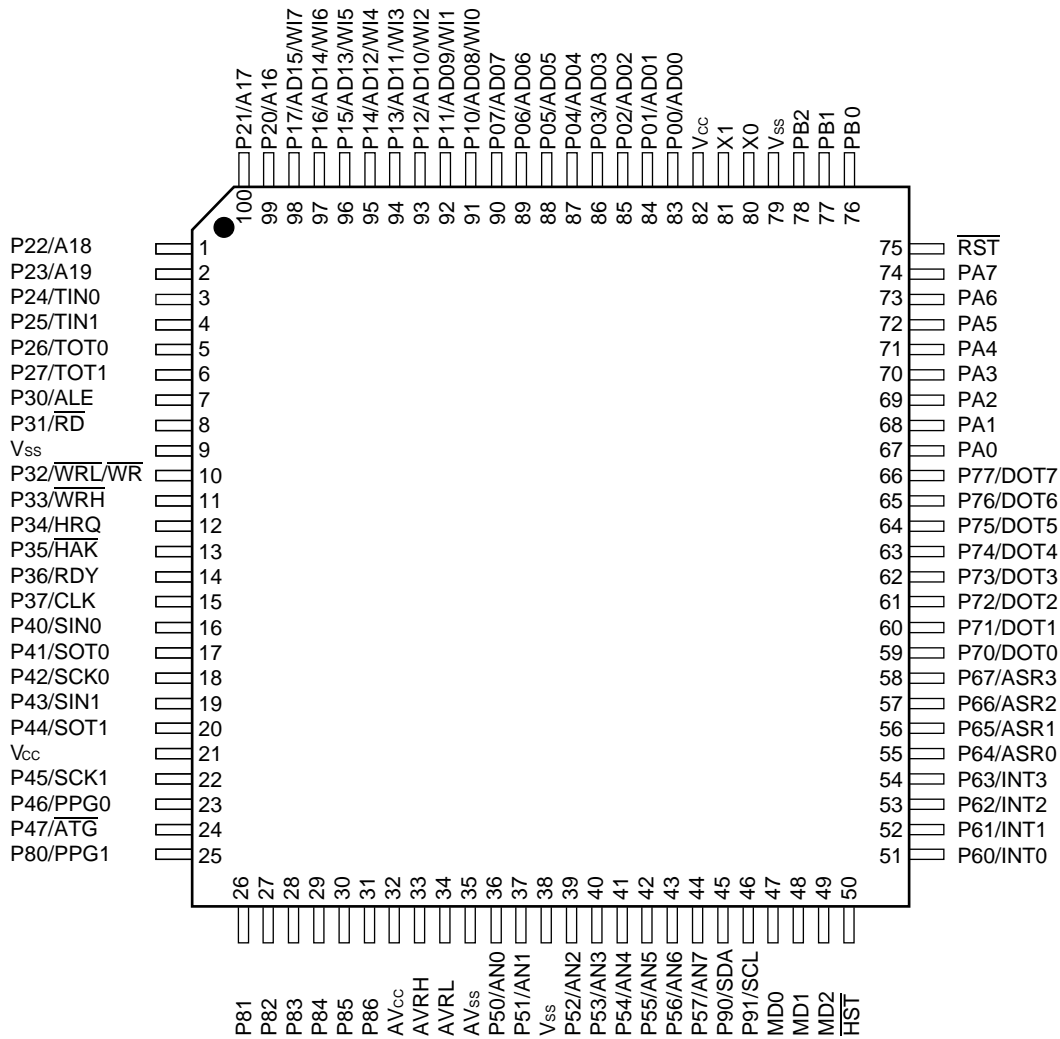

(FPT-100P-M05)

(Continued)

# MB90670/675 Series

(Continued)

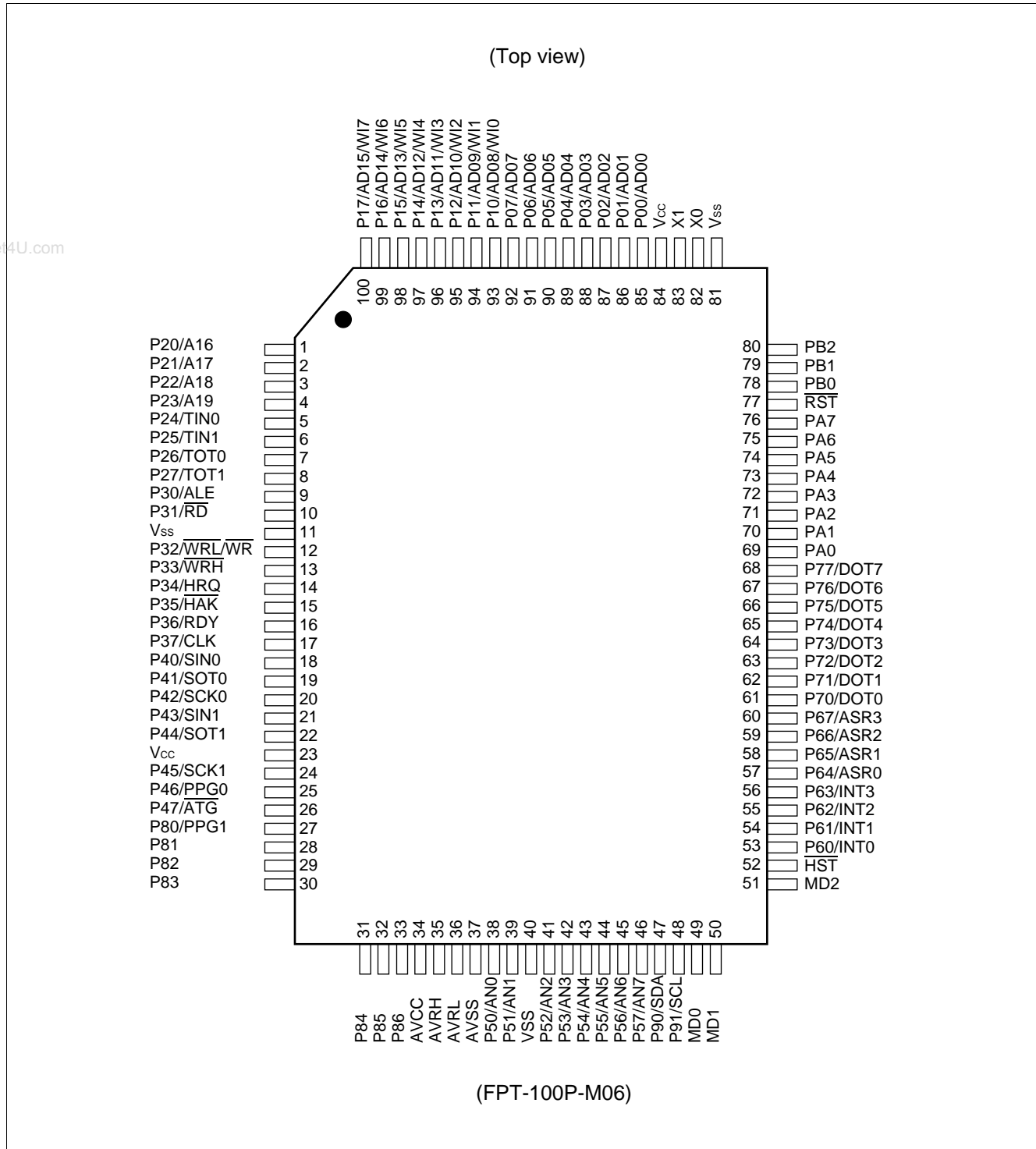

# MB90670/675 Series

## ■ PIN DESCRIPTION

Pin no.				Pin name	Circuit type	Function
LQFP -80*1	QFP -80*2	LQFP -100*3	QFP -100*4			
62	64	80	82	X0	A (Oscillation)	Crystal oscillator pins
63	65	81	83	X1		
39 to 41	41 to 43	47 to 49	49 to 51	MD0 to MD2	F (CMOS)	Input pins for selecting operation modes Connect directly to V <sub>CC</sub> or V <sub>SS</sub> .
60	62	75	77	$\overline{RST}$	H (CMOS/H)	External reset request input
42	44	50	52	$\overline{HST}$	G (CMOS/H)	Hardware standby input pin
65 to 72	67 to 74	83 to 90	85 to 92	P00 to P07	B (CMOS)	General-purpose I/O port This function is valid in the single-chip mode.
				AD00 to AD07		I/O pins for the lower 8-bit of the external address data bus This function is valid in the mode where the external bus is valid.
73 to 78, 79, 80	75 to 80, 1, 2	91 to 96, 97, 98	93 to 98, 99, 100	P10 to P15, P16, P17	B (CMOS)	General-purpose I/O port This function is valid in the single-chip mode.
				AD08 to AD13, AD14, AD15		I/O pins for the upper 8-bit of the external address data bus This function is valid in the mode where the external bus is valid.
				WI0 to WI5, WI6, WI7		I/O pins for wake-up interrupts This function is valid in the single-chip mode. Because the input of the DTP/external interrupt circuit is used as required when the DTP/external interrupt circuit is enabled, and it is necessary to stop outputs by other functions unless such outputs are made intentionally.
1, 2, 3, 4	3, 4, 5, 6	99, 100, 1, 2	1, 2, 3, 4	P20, P21, P22, P23	B (CMOS)	General-purpose I/O port This function becomes valid in the single-chip mode or the external address output control register is set to select a port.
				A16, A17, A18, 19		Output pins for the external address bus of A16 to A19 This function is valid in the mode where the external bus is valid and the upper address control register is set to select an address.

(Continued)

\*1: FPT-80P-M05

\*2: FPT-80P-M06

\*3: FPT-100P-M05

\*4: FPT-100P-M06

# MB90670/675 Series

Pin no.				Pin name	Circuit type	Function
LQFP -80*1	QFP -80*2	LQFP -100*3	QFP -100*4			
5, 6	7, 8	3, 4	5, 6	P24, P25	E (CMOS/H)	General-purpose I/O port This function is always valid.
				TIN0, TIN1		Event input pins of 16-bit reload timer 0 and 1 Because this input is used as required when the 16-bit reload timer is performing input operations, and it is necessary to stop outputs by other functions unless such outputs are made intentionally.
7, 8	9, 10	5, 6	7, 8	P26, P27	E (CMOS/H)	General-purpose I/O port This function is valid when outputs from 16-bit reload timer 0 and 1 are disabled.
				TOT0, TOT1		Output pins for 16-bit reload timer 0 and 1 This function is valid when output from 16-bit reload timer 0 and 1 are enabled.
10	12	7	9	P30	B (CMOS)	General-purpose I/O port This function is valid in the single-chip mode.
				ALE		Address latch enable output pin This function is valid in the mode where the external bus is valid.
11	13	8	10	P31	B (CMOS)	General-purpose I/O port This function is valid in the single-chip mode.
				$\overline{RD}$		Read strobe output pin for the data bus This function is valid in the mode where the external bus is valid.
12	14	10	12	P32	B (CMOS)	General-purpose I/O port This function is valid in the single-chip mode or $\overline{WRL}/\overline{WR}$ pin output is disabled.
				$\overline{WRL}$		Write strobe output pin for the data bus This function is valid when $\overline{WRL}/\overline{WR}$ pin output is enabled in the mode where external bus is valid. $\overline{WRL}$ is used for holding the lower 8-bit for write strobe in 16-bit access operations, while $\overline{WR}$ is used for holding 8-bit data for write strobe in 8-bit access operations.
				$\overline{WR}$		
13	15	11	13	P33	B (CMOS)	General-purpose I/O port This function is valid in the single-chip mode, in the external bus 8-bit mode, or $\overline{WRH}$ pin output is disabled.
				$\overline{WRH}$		Write strobe output pin for the upper 8-bit of the data bus This function is valid when the external bus 16-bit mode is selected in the mode where the external bus is valid, and $\overline{WRH}$ output pin is enabled.

(Continued)

\*1: FPT-80P-M05

\*2: FPT-80P-M06

\*3: FPT-100P-M05

\*4: FPT-100P-M06

# MB90670/675 Series

Pin no.				Pin name	Circuit type	Function
LQFP -80*1	QFP -80*2	LQFP -100*3	QFP -100*4			
14	16	12	14	P34	B (CMOS)	General-purpose I/O port This function is valid when both the single-chip mode and the hold function are disabled.
				HRQ		Hold request input pin This function is valid in the mode where the external bus is valid or when the hold function is enabled.
15	17	13	15	P35	B (CMOS)	General-purpose I/O port This function is valid when both the single-chip mode and the hold function are disabled.
				$\overline{\text{HAK}}$		Hold acknowledge output pin This function is valid in the mode where the external bus is valid or when the hold function is enabled.
16	18	14	16	P36	B (CMOS)	General-purpose I/O port This function is valid when both the single-chip mode and the external ready function are disabled.
				RDY		Ready input pin This function is valid when the external ready function is enabled in the mode where the external bus is valid.
17	19	15	17	P37	B (CMOS)	General-purpose I/O port This function is valid in the single-chip mode or when the CLK output is disabled.
				CLK		CLK output pin This function is valid when CLK output is disabled in the mode where the external bus is valid.
18	20	16	18	P40	E (CMOS/H)	General-purpose I/O port This function is always valid.
				SIN0		Serial data input pin of UART0 Because this input is used as required when UART0 is performing input operations, and it is necessary to stop outputs by other functions unless such outputs are made intentionally.
19	21	17	19	P41	E (CMOS/H)	General-purpose I/O port This function is valid when serial data output from UART0 is disabled.
				SOT0		Serial data output pin of UART0 This function is valid when serial data output from UART0 is enabled.

(Continued)

\*1: FPT-80P-M05

\*2: FPT-80P-M06

\*3: FPT-100P-M05

\*4: FPT-100P-M06

# MB90670/675 Series

Pin no.				Pin name	Circuit type	Function
LQFP -80*1	QFP -80*2	LQFP -100*3	QFP -100*4			
20	22	18	20	P42	E (CMOS/H)	General-purpose I/O port This function is valid when clock output from UART0 is disabled.
				SCK0		Clock I/O pin of UART0 This function is valid when clock output from UART0 is enabled. Because this input is used as required when UART0 is performing input operations, and it is necessary to stop outputs by other functions unless such outputs are made intentionally.
21	23	19	21	P43	E (CMOS/H)	General-purpose I/O port This function is always valid.
				SIN1		Serial data input pin of UART1 (SCI) Because this input is used as required when UART1 (SCI) is performing input operations, and it is necessary to stop outputs by other functions unless such outputs are made intentionally.
22	24	20	22	P44	E (CMOS/H)	General-purpose I/O port This function is valid when serial data output from UART1 (SCI) is disabled.
				SOT1		Serial data output pin of UART1 (SCI) This function is valid when serial data output from UART1 (SCI) is enabled.
23	25	22	24	P45	E (CMOS/H)	General-purpose I/O port This function is valid when clock output from UART1 (SCI) is disabled.
				SCK1		Clock I/O pin of UART1 (SCI) This function is valid when clock output from UART1 (SCI) is enabled. Because this input is used as required when UART1 (SCI) is performing input operations, and it is necessary to stop outputs by other functions unless such outputs are made intentionally.
24	26	23	25	P46	E (CMOS/H)	General-purpose I/O port This function is valid when waveform output from 8/16-bit PPG timer 0 is disabled.
				PPG0		Output pin of 8/16-bit PPG timer 0 This function is valid when waveform output from 8/16-bit PPG timer 0 is enabled.

(Continued)

\*1: FPT-80P-M05

\*2: FPT-80P-M06

\*3: FPT-100P-M05

\*4: FPT-100P-M06



# MB90670/675 Series

Pin no.				Pin name	Circuit type	Function
LQFP -80*1	QFP -80*2	LQFP -100*3	QFP -100*4			
25	27	24	26	P47	E (CMOS/H)	General-purpose I/O port This function is always valid.
				$\overline{ATG}$		Trigger input pin of the 8/10-bit A/D converter Because this input is used as required when the 8/10-bit A/D converter is performing input operations, and it is necessary to stop outputs by other functions unless such outputs are made intentionally.
30, 31, 33, 34, 35 to 38	32, 33, 35, 36, 37 to 40	36, 37, 38, 39, 41 to 44	38, 39, 40, 41, 43 to 46	P50, P51, P52, P53, P54 to P57	C (CMOS/H)	I/O port of an open-drain type The input function is valid when the analog input enable register is set to select a port.
				AN0, AN1, AN2, AN3, AN4 to AN7		Analog input pins of the 8/10-bit A/D converter This function is valid when the analog input enable register is set to select AD.
43 to 46	45 to 48	51 to 54	53 to 56	P60 to P63	E (CMOS/H)	General-purpose I/O port This function is always valid.
				INT0 to INT3		Request input pins of the DTP/external interrupt circuit Because this input is used as required when the DTP/external interrupt circuit is performing input operations, and it is necessary to stop outputs from other functions unless such outputs are made intentionally.
47 to 50	49 to 52	55 to 58	57 to 60	P64 to P67	E (CMOS/H)	General-purpose I/O port This function is always valid.
				ASR0 to ASR3		Sample data input pins for ICU0 to ICU3 Because this input is used as required when the input capture (ICU) is performing input operations, and it is necessary to stop outputs from other functions unless such outputs are made intentionally.
51 to 58	53 to 60	59 to 66	61 to 68	P70 to P77	E (CMOS/H)	General-purpose I/O port This function is valid when waveform output from the output compare (OCU) is disabled.
				DOT0 to DOT7		Waveform output pins of OCU0 and OCU1 This function is valid when waveform output from the output compare (OCU) is enabled and output from the port is selected.

(Continued)

\*1: FPT-80P-M05

\*2: FPT-80P-M06

\*3: FPT-100P-M05

\*4: FPT-100P-M06

# MB90670/675 Series

(Continued)

Pin no.				Pin name	Circuit type	Function
LQFP -80*1	QFP -80*2	LQFP -100*3	QFP -100*4			
59	61	25	27	P80	E (CMOS/H)	General-purpose I/O port This function is valid when waveform output from 8/16-bit PPG timer 1 is disabled.
				PPG1		Output pin of 8/16-bit PPG timer 1 This function is valid when waveform output from 8/16-bit PPG timer 1 is enabled.
—	—	26 to 31	28 to 33	P81 to P86	E (CMOS/H)	General-purpose I/O port This function is always valid.
—	—	45	47	P90	D (NMOS/H)	I/O port of an open-drain type This function is always valid.
				SDA		I/O pin of the I <sup>2</sup> C interface This function is valid when operation of the I <sup>2</sup> C interface is enabled. Hold the port output in the high-impedance status (PDR = 1) when the I <sup>2</sup> C interface is in operation.
—	—	46	48	P91	D (NMOS/H)	I/O port of an open-drain type This function is always valid.
				SCL		Clock I/O pin of the I <sup>2</sup> C interface This function is valid when operation of the I <sup>2</sup> C interface is enabled. Hold the port output in the high-impedance status (PDR = 1) when the I <sup>2</sup> C interface is in operation.
—	—	67 to 74	69 to 76	PA0 to PA7	E (CMOS/H)	General-purpose I/O port This function is always valid.
—	—	76 to 78	78 to 80	PB0 to PB2	E (CMOS/H)	General-purpose I/O port This function is always valid.
64	66	21, 82	23, 84	V <sub>CC</sub>	Power supply	Power supply to the digital circuit
9, 32, 61	11, 34, 63	9, 40, 79	11, 42, 81	V <sub>SS</sub>	Power supply	Ground level of the digital circuit
26	28	32	34	AV <sub>CC</sub>	Power supply	Power supply to the analog circuit Make sure to turn on/turn off this power supply with a voltage exceeding AV <sub>CC</sub> applied to V <sub>CC</sub> .
27	29	33	35	AVRH	Power supply	Reference voltage input to the analog circuit Make sure to turn on/turn off this power supply with a voltage exceeding AVRH applied to AV <sub>CC</sub> .
28	30	34	36	AVRL	Power supply	Reference voltage input to the analog circuit
29	31	35	37	AV <sub>SS</sub>	Power supply	Ground level of the analog circuit

\*1: FPT-80P-M05

\*2: FPT-80P-M06

\*3: FPT-100P-M05

\*4: FPT-100P-M06

# MB90670/675 Series

## I/O CIRCUIT TYPE

Type	Circuit	Remarks
A		<ul style="list-style-type: none"> <li>External clock frequency 3 MHz to 32 MHz</li> <li>Oscillation feedback resistor approx. 1MΩ</li> </ul>
B		<ul style="list-style-type: none"> <li>CMOS level input/output (with standby control)</li> <li>Pull-up option selectable (with standby control)</li> <li>No pull-up resistor in the MB90V670</li> </ul>
C		<ul style="list-style-type: none"> <li>N-ch open-drain output</li> <li>CMOS level hysteresis input (with A/D control)</li> </ul>
D		<ul style="list-style-type: none"> <li>NMOS open-drain output</li> <li>CMOS level hysteresis input (with standby control)</li> </ul>

(Continued)

# MB90670/675 Series

(Continued)

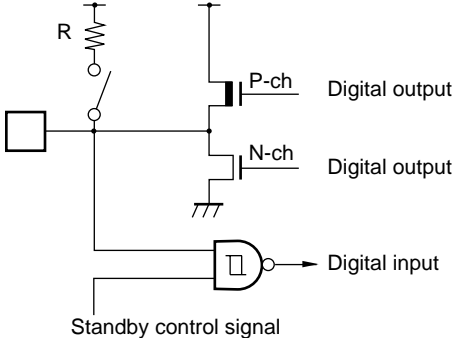
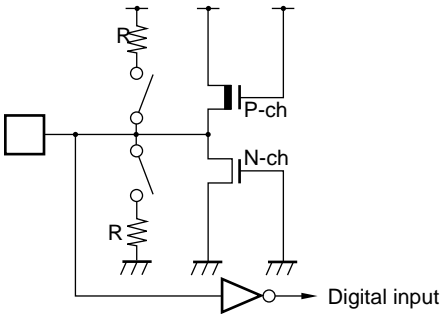
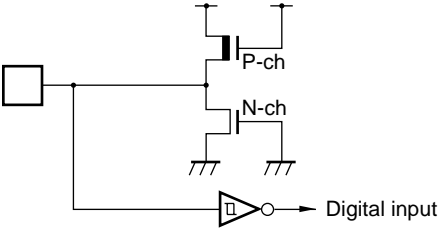
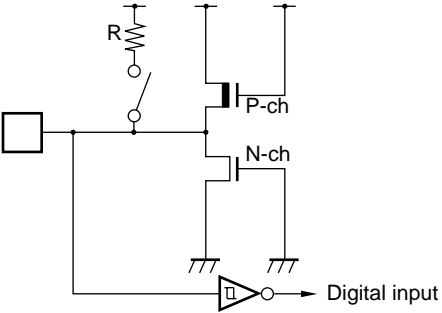
Type	Circuit	Remarks
E	 <p>The diagram shows a CMOS output stage. A pull-up resistor R is connected to the output node. A standby control signal is connected to the gates of both the P-channel and N-channel MOSFETs. The output node is connected to a digital input through an AND gate.</p>	<ul style="list-style-type: none"> <li>• CMOS level output</li> <li>• CMOS level hysteresis input (with standby control)</li> <li>• Pull-up option selectable (with standby control)</li> <li>• No pull-up resistor in the MB90V670</li> </ul>
F	 <p>The diagram shows a CMOS input/output stage. It features a pull-up resistor R and a pull-down resistor R. The output node is connected to a digital input through an inverter.</p>	<ul style="list-style-type: none"> <li>• CMOS level input/output (without standby control)</li> <li>• Pull-up/pull-down option selectable (without stand-by control)</li> <li>• In mask ROM versions, MD2 pin is fixed to pull-down resistor, and optionally selectable the resistor in other pins.</li> <li>• The MB90V670 has no pull-up/pull-down resistors.</li> </ul>
G	 <p>The diagram shows a CMOS input/output stage without resistors. The output node is connected to a digital input through an inverter.</p>	<ul style="list-style-type: none"> <li>• CMOS level hysteresis input (without standby control)</li> </ul>
H	 <p>The diagram shows a CMOS input/output stage with a pull-up resistor R. The output node is connected to a digital input through an inverter.</p>	<ul style="list-style-type: none"> <li>• CMOS level hysteresis input (without standby control)</li> <li>• Pull-up option selectable (without standby control)</li> <li>• No pull-up resistor in the MB90V670</li> </ul>

## ■ HANDLING DEVICES

### 1. Make Sure that the Voltage not Exceed the Maximum Rating (to Avoid a Latch-up).

In CMOS ICs, a latch-up phenomenon is caused when a voltage exceeding  $V_{CC}$  or a voltage below  $V_{SS}$  is applied to input or output pins or a voltage exceeding the rating is applied across  $V_{CC}$  and  $V_{SS}$ .

When a latch-up is caused, the power supply current may be dramatically increased causing resultant thermal break-down of devices. To avoid the latch-up, make sure that the voltage not exceed the maximum rating.

In turning on/turning off the analog power supply, make sure the analog power voltage ( $AV_{CC}$ ,  $AVRH$ ) and analog input voltages not exceed the digital voltage ( $V_{CC}$ ).

### 2. Connection of Unused Pins

Leaving unused pins open may result in abnormal operations. Clamp the pin level by connecting it to a pull-up or a pull-down resistor.

### 3. Notes on Using External Clock

In using the external clock, drive X0 pin only and leave X1 pin unconnected.

- Using external clock

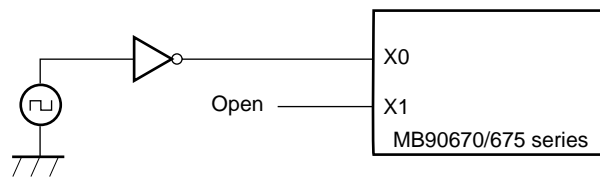

### 4. Power Supply Pins

In products with multiple  $V_{CC}$  or  $V_{SS}$  pins, the pins of a same potential are internally connected in the device to avoid abnormal operations including latch-up. However, connect the pins external power and ground lines to lower the electro-magnetic emission level and abnormal operation of strobe signals caused by the rise in the ground level, and to conform to the total current rating.

Make sure to connect  $V_{CC}$  and  $V_{SS}$  pins via lowest impedance to power lines.

It is recommended to provide a bypass capacitor of around  $0.1 \mu\text{F}$  between  $V_{CC}$  and  $V_{SS}$  pin near the device.

### 5. Crystal Oscillator Circuit

Noises around X0 or X1 pins may be possible causes of abnormal operations. Make sure to provide bypass capacitors via shortest distance from X0, X1 pins, crystal oscillator (or ceramic resonator) and ground lines, and make sure, to the utmost effort, that lines of oscillation circuit not cross the lines of other circuits.

It is highly recommended to provide a printed circuit board art work surrounding X0 and X1 pins with an grand area for stabilizing the operation.

### 6. Turning-on Sequence of Power Supply to A/D Converter and Analog Inputs

Make sure to turn on the A/D converter power supply ( $AV_{CC}$ ,  $AVRH$ ,  $AVRL$ ) and analog inputs ( $AN0$  to  $AN7$ ) after turning-on the digital power supply ( $V_{CC}$ ).

Turn-off the digital power after turning off the A/D converter supply and analog inputs. In this case, make sure that the voltage not exceed  $AVRH$  or  $AV_{CC}$  (turning on/off the analog and digital power supplies simultaneously is acceptable).

# MB90670/675 Series

## 7. Connection of Unused Pins of A/D Converter

Connect unused pins of A/D converter to  $AV_{CC} = V_{CC}$ ,  $AV_{SS} = AVRH = V_{SS}$ .

## 8. “MOV @AL, AH”, “MOVW @AL, AH” Instructions

When the above instruction is performed to I/O space, an unnecessary writing operation (#FF, #FFFF) may be performed in the internal bus.

Use the compiler function for inserting an NOP instruction before the above instructions to avoid the writing operation.

Accessing RAM space with the above instruction does not cause any problem.

## 9. Initialization

In the device, there are internal registers which is initialized only by a power-on reset. To initialize these registers, turning on the power again.

## 10. Caution on operations during PLL clock mode

If the PLL clock mode is selected, the microcontroller attempt to be working with the self-oscillating circuit even when there is no external oscillator or external clock input is stopped. Performance of this operation, however, cannot be guaranteed.

## PROGRAMMING TO THE ONE-TIME PROM ON THE MB90P673/P678

The MB90P673 and MB90P678 has a PROM mode for emulation operation of the MBM27C1000/1000A, to which writing codes by a general-purpose ROM writer can be done via a dedicated adapter. Please note that the device is not compatible with the electronic signature (device ID code) mode.

### 1. Writing Sequence

The memory map for the PROM mode is shown as follows. Write option data to the option setting area according by referring to “7. PROM Option Bit Map”.

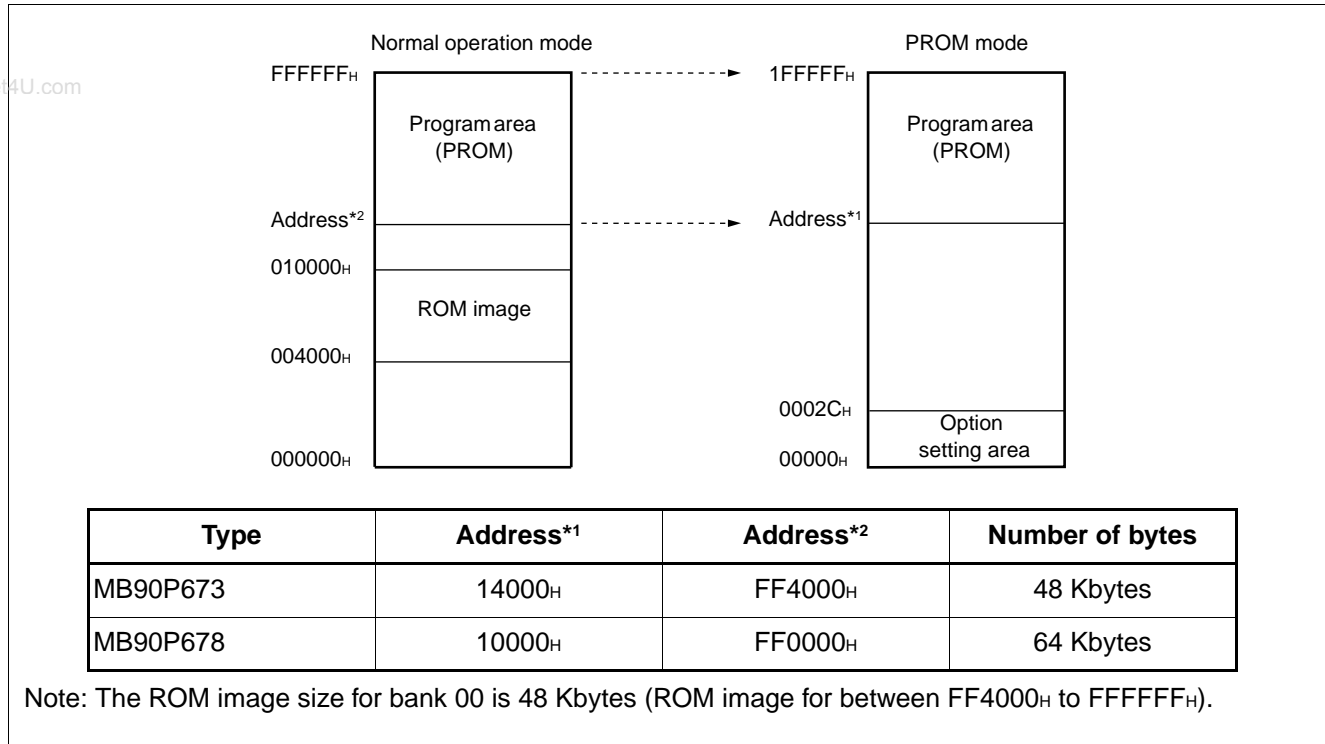

Write data to the one-time PROM microcontrollers according to the following sequence.

- (1) Set the PROM programmer to select the MBM27C1000/1000A.
- (2) Load the program data to the ROM programmer address \*1 to 1FFFFFFH. To select a PROM option, load the option data from 00000H to 0002CH referring to “7. PROM Option Bit Map”.
- (3) Set the chip to the adapter socket and load the socket to the ROM programmer. Make sure that the device and adapter socket are properly oriented.
- (4) Program from 00000H to 1FFFFFFH.

Notes:

- In mask-ROM products, there is no PROM mode and it is impossible to read data by a ROM programmer.
- Contact sales personnel when purchasing a ROM programmer.

### 2. Program Mode

In the MB90P673/P678, all the bits are set to “1” upon shipping from FUJITSU or erasing operation. To write data, set desired bit selectively to “0”. However it is impossible to write electronically to the bits.

# MB90670/675 Series

## 3. Recommended Screening Conditions

High-temperature aging is recommended as the pre-assembly screening procedure for a product with a blanked One-time PROM microcomputer program.

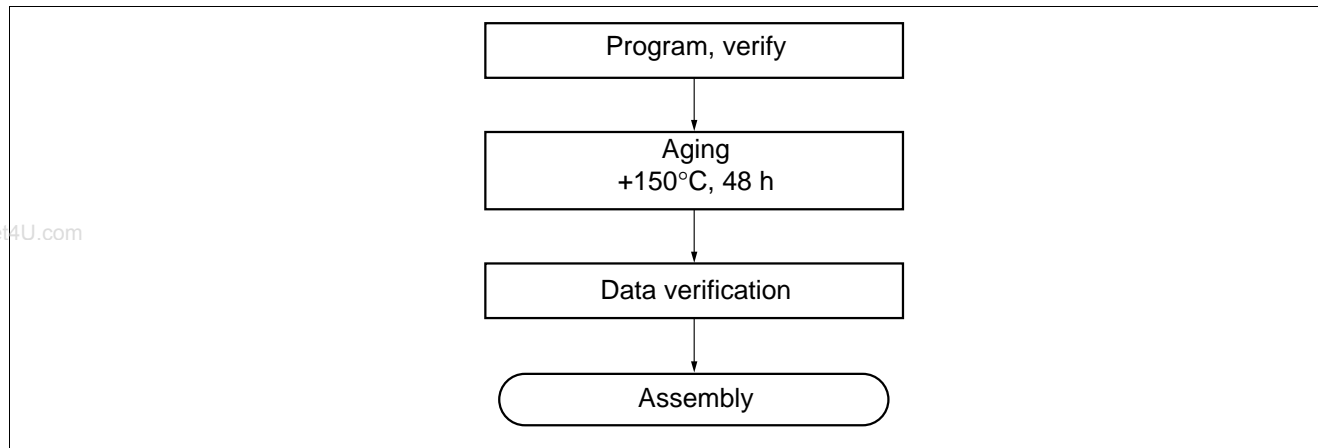

## 4. Programming Yield

All bits cannot be programmed at Fujitsu shipping test to a blanked One-time PROM microcomputer, due to its nature. For this reason, a programming yield of 100% cannot be assured at all times.

## 5. EPROM Programmer Socket Adapter and Recommended Programmer Manufacturer

Part no.		MB90P673PF	MB90P673PFV	MB90P678PF	MB90P678PFV	
Package		QFP-80	LQFP-80	QFP-100	LQFP-100	
Compatible socket adapter Sun Hayato Co., Ltd.		ROM-80QF-32DP-16L	ROM-80SQF-32DP-16L	ROM-100QF-32DP-16L	ROM-100SQF-32DP-16L	
Recommended programmer manufacturer and programmer name	Minato Electronics Inc.	1890A	—	—	—	Recommended
		1891	—	—	—	Recommended
		1930	—	—	—	Recommended
	Data I/O Co., Ltd.	UNISITE	—	—	—	Recommended
		3900	—	—	—	Recommended
		2900	—	—	—	Recommended

Inquiry: San Hayato Co., Ltd.: TEL: (81)-3-3986-0403  
FAX: (81)-3-5396-9106

Minato Electronics Inc.: TEL: USA (1)-916-348-6066  
JAPAN (81)-45-591-5611

Data I/O Co., Ltd.: TEL: USA/ASIA (1)-206-881-6444  
EUROPE (49)-8-985-8580



# MB90670/675 Series

## 6. Pin Assignment for EPROM Mode

- MBM27C1000/1000A pin compatible

MBM27C1000/1000A		MB90P673/MB90P678	
Pin no.	Pin name	Pin no.	Pin name
1	V <sub>PP</sub>	Refer to pin assignments.	MD2
2	OE		P32
3	A15		P17
4	A12		P14
5	A07		P27
6	A06		P26
7	A05		P25
8	A04		P24
9	A03		P23
10	A02		P22
11	A01		P21
12	A00		P20
13	D00		P00
14	D01		P01
15	D02		P02
16	GND		V <sub>SS</sub>

MBM27C1000/1000A		MB90P673/MB90P678	
Pin no.	Pin name	Pin no.	Pin name
32	V <sub>CC</sub>	Refer to pin assignments.	V <sub>CC</sub>
31	PGM		P33
30	N.C.		—
29	A14		P16
28	A13		P15
27	A08		P10
26	A09		P11
25	A11		P13
24	A16		P30
23	A10		P12
22	CE		P31
21	D07		P07
20	D06		P06
19	D05		P05
18	D04		P04
17	D03		P03

- Pin assignments for products not compatible with MBM27C1000/1000A

- Power supply, GND connected pin

Pin no.	Pin name	processing
Refer to pin assignments.	MD0 MD1 X0	Connect a pull-up resistor of 4.7 kΩ.
	X1	OPEN
	AV <sub>CC</sub> AVRH P37 P40 to P47 P50 to P57 P60 to P67 P70 to P77 P80 to P86 P90 P91 PA0 to PA7 PB0 to PB2	Connect a pull-up resistor having a resistance of approximately 1 MΩ to each pin.

Type	Pin no.	Pin name
Power supply	Refer to pin assignments.	HST V <sub>CC</sub>
GND	Refer to pin assignments.	P34 P35 P36 RST AVRL AV <sub>SS</sub> V <sub>SS</sub>

Note: Only MB90675 series has P81 to P86, P90, P91, PA0 to PA7, PB0 to PB2 pins.

# MB90670/675 Series

## 7. PROM Option Bit Map

Address	bit 7	bit 6	bit 5	bit 4	bit 3	bit 2	bit 1	bit 0
00000H	Vacancy	$\overline{RST}$ Pull-up 1: No 0: Yes	Vacancy	MD1 Pull-up 1: No 0: Yes	MD1 Pull-down 1: No 0: Yes	MD0 Pull-up 1: No 0: Yes	MD0 Pull-down 1: No 0: Yes	Vacancy
00004H	P07 Pull-up 1: No 0: Yes	P06 Pull-up 1: No 0: Yes	P05 Pull-up 1: No 0: Yes	P04 Pull-up 1: No 0: Yes	P03 Pull-up 1: No 0: Yes	P02 Pull-up 1: No 0: Yes	P01 Pull-up 1: No 0: Yes	P00 Pull-up 1: No 0: Yes
00008H	P17 Pull-up 1: No 0: Yes	P16 Pull-up 1: No 0: Yes	P15 Pull-up 1: No 0: Yes	P14 Pull-up 1: No 0: Yes	P13 Pull-up 1: No 0: Yes	P12 Pull-up 1: No 0: Yes	P11 Pull-up 1: No 0: Yes	P10 Pull-up 1: No 0: Yes
0000CH	P27 Pull-up 1: No 0: Yes	P26 Pull-up 1: No 0: Yes	P25 Pull-up 1: No 0: Yes	P24 Pull-up 1: No 0: Yes	P23 Pull-up 1: No 0: Yes	P22 Pull-up 1: No 0: Yes	P21 Pull-up 1: No 0: Yes	P20 Pull-up 1: No 0: Yes
00010H	P37 Pull-up 1: No 0: Yes	P36 Pull-up 1: No 0: Yes	P35 Pull-up 1: No 0: Yes	P34 Pull-up 1: No 0: Yes	P33 Pull-up 1: No 0: Yes	P32 Pull-up 1: No 0: Yes	P31 Pull-up 1: No 0: Yes	P30 Pull-up 1: No 0: Yes
00014H	P47 Pull-up 1: No 0: Yes	P46 Pull-up 1: No 0: Yes	P45 Pull-up 1: No 0: Yes	P44 Pull-up 1: No 0: Yes	P43 Pull-up 1: No 0: Yes	P42 Pull-up 1: No 0: Yes	P41 Pull-up 1: No 0: Yes	P40 Pull-up 1: No 0: Yes
0001CH	P67 Pull-up 1: No 0: Yes	P66 Pull-up 1: No 0: Yes	P65 Pull-up 1: No 0: Yes	P64 Pull-up 1: No 0: Yes	P63 Pull-up 1: No 0: Yes	P62 Pull-up 1: No 0: Yes	P61 Pull-up 1: No 0: Yes	P60 Pull-up 1: No 0: Yes
00020H	P77 Pull-up 1: No 0: Yes	P76 Pull-up 1: No 0: Yes	P75 Pull-up 1: No 0: Yes	P74 Pull-up 1: No 0: Yes	P73 Pull-up 1: No 0: Yes	P72 Pull-up 1: No 0: Yes	P71 Pull-up 1: No 0: Yes	P70 Pull-up 1: No 0: Yes
00024H	Vacancy	P86 Pull-up 1: No 0: Yes	P85 Pull-up 1: No 0: Yes	P84 Pull-up 1: No 0: Yes	P83 Pull-up 1: No 0: Yes	P82 Pull-up 1: No 0: Yes	P81 Pull-up 1: No 0: Yes	P80 Pull-up 1: No 0: Yes
00028H	PA5 Pull-up 1: No 0: Yes	PA4 Pull-up 1: No 0: Yes	PA3 Pull-up 1: No 0: Yes	PA2 Pull-up 1: No 0: Yes	PA1 Pull-up 1: No 0: Yes	PA0 Pull-up 1: No 0: Yes	Vacancy	Vacancy
0002CH	Vacancy	Vacancy	Vacancy	PB2 Pull-up 1: No 0: Yes	PB1 Pull-up 1: No 0: Yes	PB0 Pull-up 1: No 0: Yes	PA7 Pull-up 1: No 0: Yes	PA6 Pull-up 1: No 0: Yes

### Notes:

- Data "1" must be programmed to the reserved bits and address other than listed above.
- Only MB90P678 has pull-up options for P81 to P86, PA0 to PA7, and PB0 to PB2 pins.
- Data "1" must be programmed for the MB90P673.

# MB90670/675 Series

## ■ BLOCK DIAGRAM

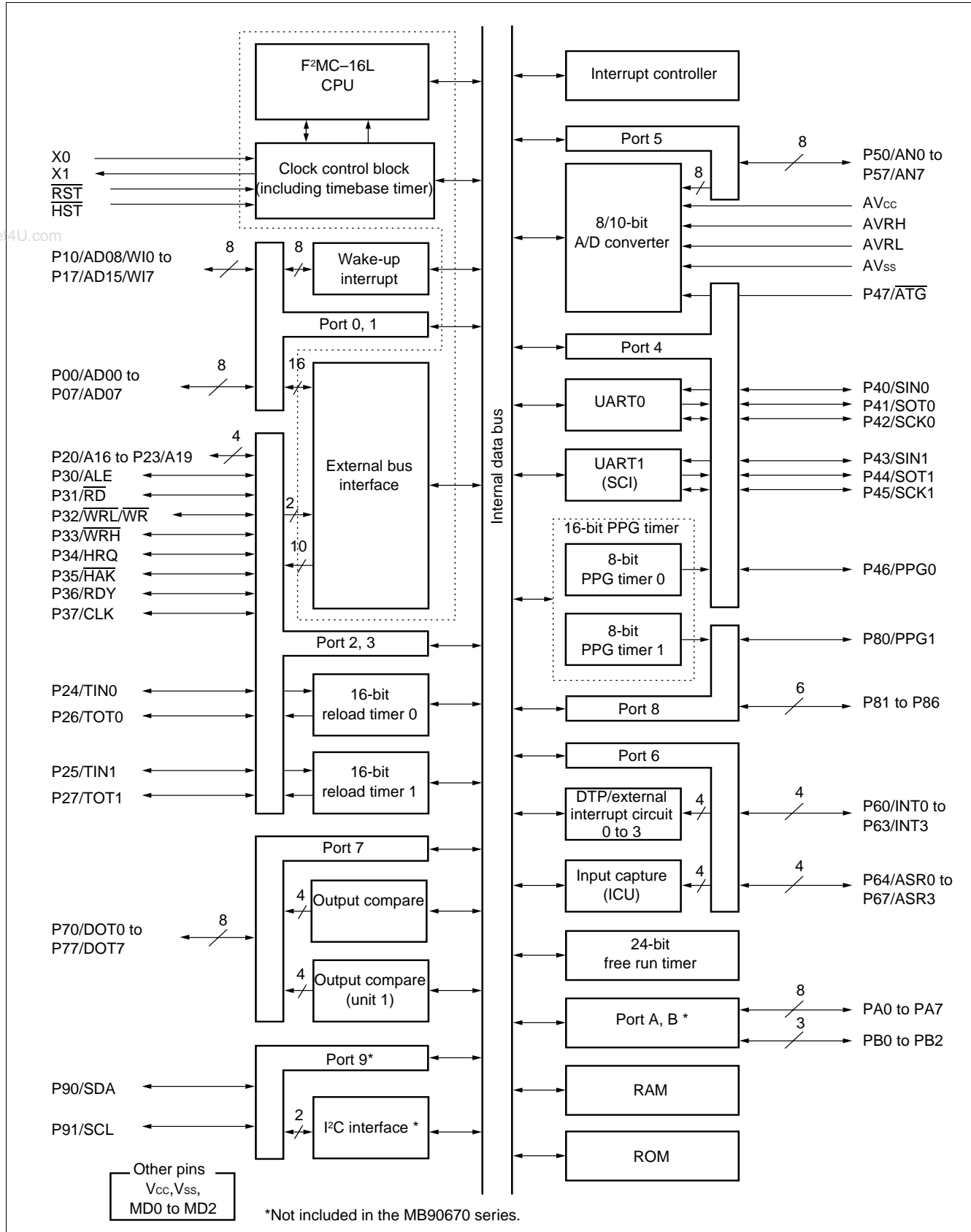

# MB90670/675 Series

## MEMORY MAP

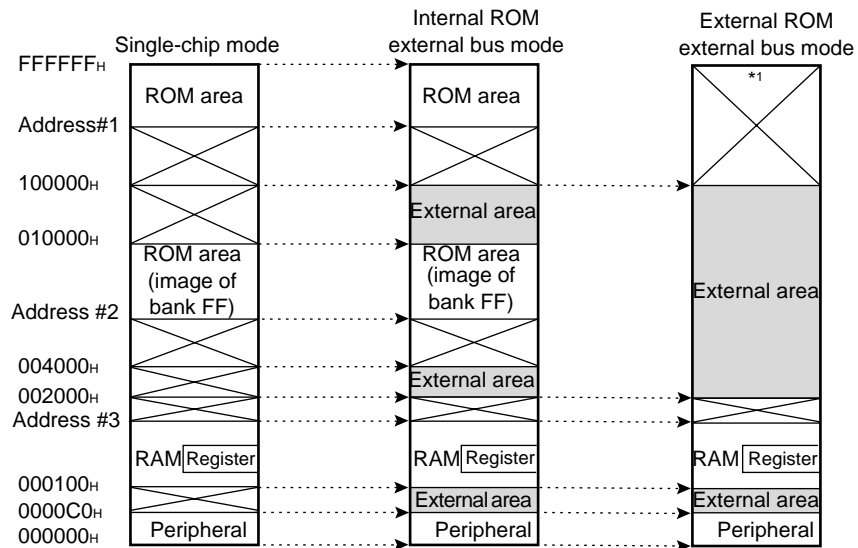

Part number	Address #1*2	Address #2*2	Address #3*2
MB90671	FFC000H	00C000H	000380H
MB90672	FF8000H	008000H	000780H
MB90673	FF4000H	004000H	000900H
MB90T673	—	—	000900H
MB90P673	FF4000H	004000H	000900H
MB90676	FF8000H	008000H	000780H
MB90677	FF4000H	004000H	000900H
MB90678	FF0000H	004000H	000D00H
MB90T678	—	—	000D00H
MB90P678	FF0000H	004000H	000D00H

- : Internal access memory
- : External access memory
- : Inhibited area

\*1: The same external memory is accessed for bank 0F, 1F, 2F through FF.

\*2: Addresses #1, #2 and #3 are unique to the product type.

### Notes:

- The ROM data of bank FF is reflected in the upper address of bank 00, realizing effective use of the C compiler small model. The lower 16-bit of bank FF and the lower 16-bit of bank 00 is assigned to the same address, enabling reference of the table on the ROM without stating “far”.  
However, the ROM area of the MB90678/P678 exceeds 48 Kbytes, and for this reason, the image from FF4000H to FFFFFFFH is reflected on bank 00 and image from FF0000H to FF3FFFH bank FF only.
- In the MB90670/675 series, the upper 4-bit of the address are not output to the external bus. For this reason, the maximum area accessible is 1 Mbyte. The same address is accessed through different banks in different images.  
For example, accessing “A00000H” and “B00000H” accesses the same address on the external bus.
- To prevent the memory or I/O from being accessed through images, and the data from being destroyed, it is recommended to limit number of banks to a maximum of 16 so that the banks are mapped without interfering each other. Caution must be also taken when masking the upper address with the external address output control register (HACR).

## ■ F<sup>2</sup>MC-16L CPU PROGRAMMING MODEL

### (1) Dedicated Registers

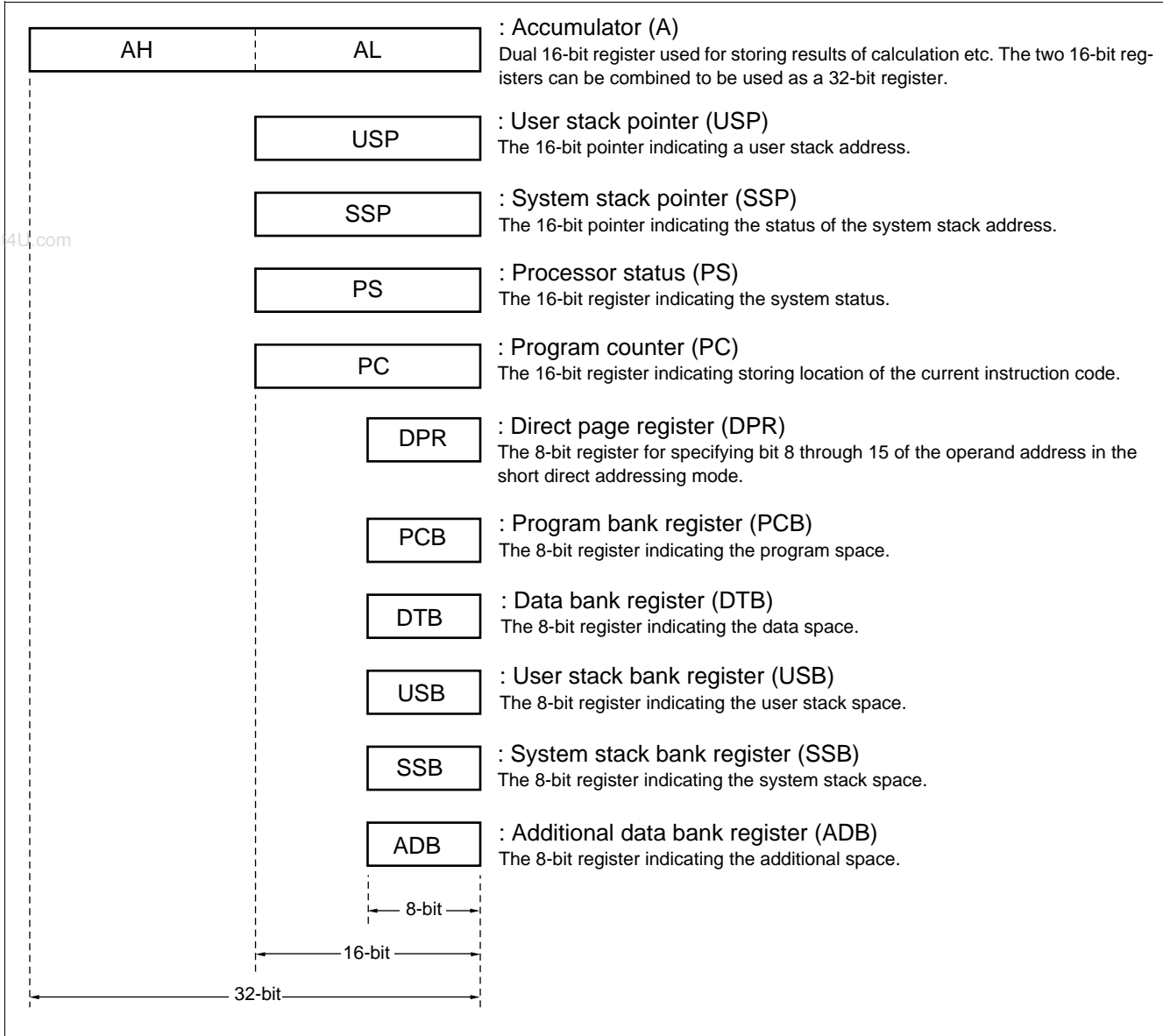

# MB90670/675 Series

## (2) General-purpose Registers

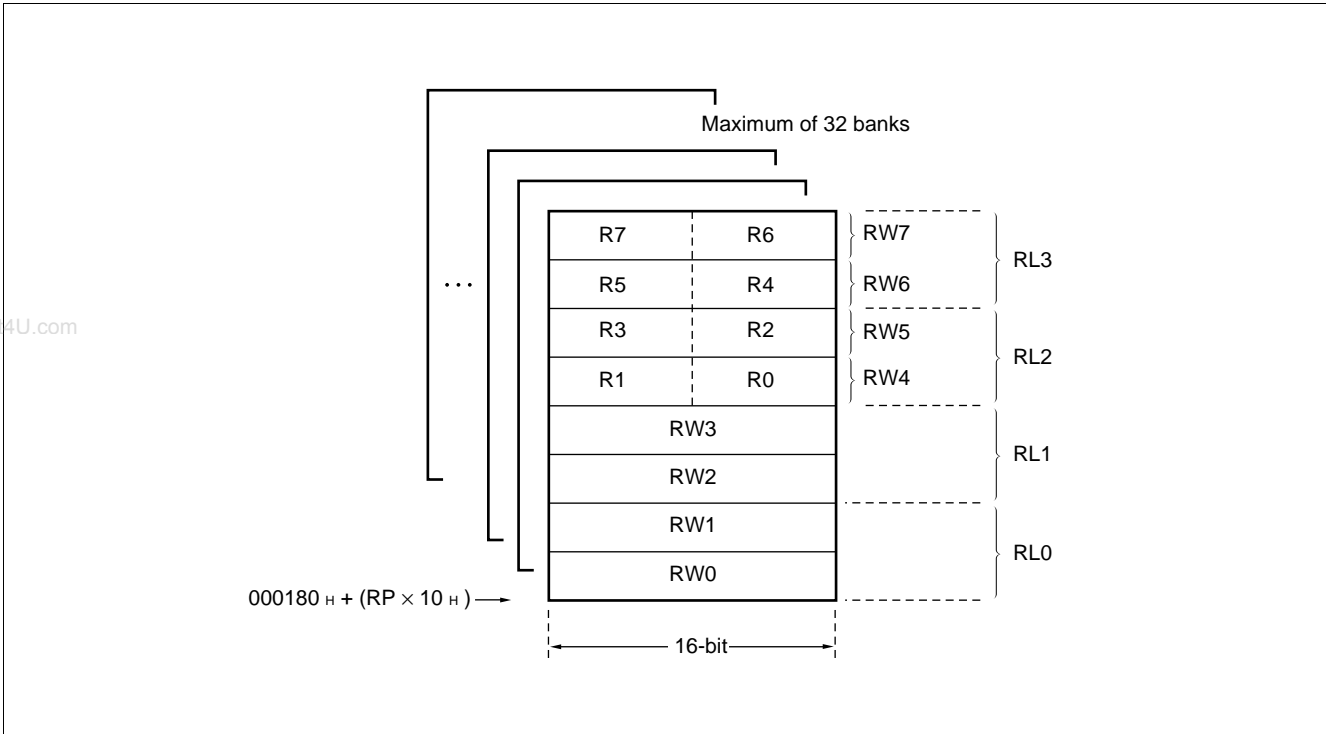

## (3) Processor Status (PS)

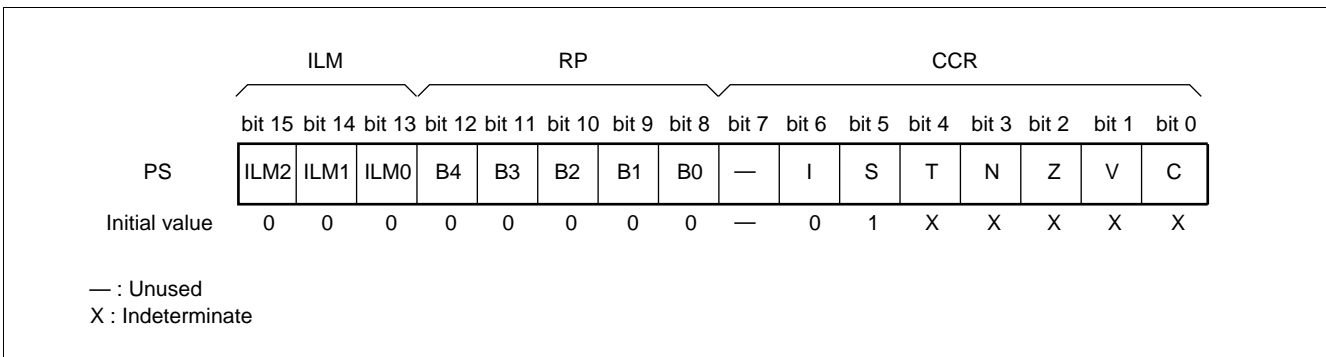

# MB90670/675 Series

## ■ I/O MAP

Address	Abbreviated register name	Register name	Read/write	Resource name	Initial value
00000H	PDR0	Port 0 data register	R/W	Port 0	XXXXXXXX <sub>B</sub>
00001H	PDR1	Port 1 data register	R/W	Port 1	XXXXXXXX <sub>B</sub>
00002H	PDR2	Port 2 data register	R/W	Port 2	XXXXXXXX <sub>B</sub>
00003H	PDR3	Port 3 data register	R/W	Port 3	XXXXXXXX <sub>B</sub>
00004H	PDR4	Port 4 data register	R/W	Port 4	XXXXXXXX <sub>B</sub>
00005H	PDR5	Port 5 data register	R/W	Port 5	1 1 1 11 1 1 1 <sub>B</sub>
00006H	PDR6	Port 6 data register	R/W	Port 6	XXXXXXXX <sub>B</sub>
00007H	PDR7	Port 7 data register	R	Port 7	XXXXXXXX <sub>B</sub>
00008H	PDR8	Port 8 data register	R/W	Port 8 <sup>*5</sup>	-XXXXXXXX <sub>B</sub>
00009H	PDR9	Port 9 data register	R/W	Port 9 <sup>*5</sup>	----- 1 1 <sub>B</sub>
0000AH	PDRA	Port A data register	R/W	Port A <sup>*5</sup>	XXXXXXXX <sub>B</sub>
0000BH	PDRB	Port B data register	R/W	Port B <sup>*5</sup>	----- XXX <sub>B</sub>
0000CH to 0000EH	(Vacancy) <sup>*3</sup>				
0000FH	EIFR	Wake-up interrupt flag register	R/W	Wake-up interrupt	----- 0 <sub>B</sub>
00010H	DDR0	Port 0 data direction register	R/W	Port 0	00000000 <sub>B</sub>
00011H	DDR1	Port 1 data direction register	R/W	Port 1	00000000 <sub>B</sub>
00012H	DDR2	Port 2 data direction register	R/W	Port 2	00000000 <sub>B</sub>
00013H	DDR3	Port 3 data direction register	R/W	Port 3	00000000 <sub>B</sub>
00014H	DDR4	Port 4 data direction register	R/W	Port 4	00000000 <sub>B</sub>
00015H	ADER	Analog input enable register	R/W	Port 5, analog input	11111111 <sub>B</sub>
00016H	DDR6	Port 6 data direction register	R/W	Port 6	00000000 <sub>B</sub>
00017H	DDR7	Port 7 data direction register	R/W	Port 7	00000000 <sub>B</sub>
00018H	DDR8	Port 8 data direction register	R/W	Port 8 <sup>*5</sup>	-0000000 <sub>B</sub>
00019H	(Vacancy) <sup>*3</sup>				
0001AH	DDRA	Port A data direction register	R/W	Port A <sup>*5</sup>	00000000 <sub>B</sub>
0001BH	DDRB	Port B data direction register	R/W	Port B <sup>*5</sup>	----- 000 <sub>B</sub>
0001CH to 0001EH	(Vacancy) <sup>*3</sup>				
0001FH	EICR	Wake-up interrupt enable register	W	Wake-up interrupt	00000000 <sub>B</sub>

(Continued)

# MB90670/675 Series

Address	Abbreviated register name	Register name	Read/write	Resource name	Initial value
000020 <sub>H</sub>	UMC0	Mode control register 0	R/W!	UART0	0000100 <sub>B</sub>
000021 <sub>H</sub>	USR0	Status register 0	R/W!		00010000 <sub>B</sub>
000022 <sub>H</sub>	UIDR0/ UODR0	Input data register 0/ output data register 0	R/W		XXXXXXXX <sub>B</sub>
000023 <sub>H</sub>	URD0	Rate and data register 0	R/W		00000000 <sub>B</sub>
000024 <sub>H</sub>	SMR1	Mode register 1	R/W	UART1 (SCI)	00000000 <sub>B</sub>
000025 <sub>H</sub>	SCR1	Control register 1	R/W!		00000100 <sub>B</sub>
000026 <sub>H</sub>	SIDR1/ SODR1	Input data register 1/ output data register 1	R/W		XXXXXXXX <sub>B</sub>
000027 <sub>H</sub>	SSR1	Status register 1	R/W!		00001-00 <sub>B</sub>
000028 <sub>H</sub>	ENIR	DTP/interrupt enable register	R/W	DTP/external in- terrupt circuit	---- 0000 <sub>B</sub>
000029 <sub>H</sub>	EIRR	DTP/interrupt factor register	R/W		---- 0000 <sub>B</sub>
00002A <sub>H</sub>	ELVR	Request level setting register	R/W		00000000 <sub>B</sub>
00002B <sub>H</sub>	(Vacancy) <sup>*3</sup>				
00002C <sub>H</sub>	ADCS	A/D convertor control status reg- ister	R/W!	8/10-bit A/D converter	00000000 <sub>B</sub>
00002D <sub>H</sub>					00000000 <sub>B</sub>
00002E <sub>H</sub>	ADCR	A/D convertor data register	R/W! <sup>*4</sup>		XXXXXXXX <sub>B</sub>
00002F <sub>H</sub>					000000XX <sub>B</sub>
000030 <sub>H</sub>	PPGC0	PPG0 operating mode control register	R/W!	8/16-bit PPG timer 0	0-000001 <sub>B</sub>
000031 <sub>H</sub>	PPGC1	PPG1 operating mode control register	R/W!	8/16-bit PPG timer 1	00000000 <sub>B</sub>
000032 <sub>H</sub>	(Vacancy) <sup>*3</sup>				
000033 <sub>H</sub>	(Vacancy) <sup>*3</sup>				
000034 <sub>H</sub>	PRLLO	PPG0 reload register	R/W	8/16-bit PPG timer 0	XXXXXXXX <sub>B</sub>
000035 <sub>H</sub>	PRLH0		R/W		XXXXXXXX <sub>B</sub>
000036 <sub>H</sub>	PRLLO	PPG1 reload register	R/W	8/16-bit PPG timer 1	XXXXXXXX <sub>B</sub>
000037 <sub>H</sub>	PRLH1		R/W		XXXXXXXX <sub>B</sub>
000038 <sub>H</sub>	TMCSR0	Timer control status register 0	R/W!	16-bit reload timer 0	00000000 <sub>B</sub>
000039 <sub>H</sub>					---- 0000 <sub>B</sub>
00003A <sub>H</sub>	TMR0/ TMRLR0	16-bit timer register 0/ 16-bit reload register 0	R/W		XXXXXXXX <sub>B</sub>
00003B <sub>H</sub>					XXXXXXXX <sub>B</sub>
00003C <sub>H</sub>	TMCSR1	Timer control status register 1	R/W!	16-bit reload timer 1	00000000 <sub>B</sub>
00003D <sub>H</sub>					---- 0000 <sub>B</sub>
00003E <sub>H</sub>	TMR1/ TMRLR1	16-bit timer register 1/ 16-bit reload register 1	R/W		XXXXXXXX <sub>B</sub>
00003F <sub>H</sub>					XXXXXXXX <sub>B</sub>

(Continued)



# MB90670/675 Series

Address	Abbreviated register name	Register name	Read/write	Resource name	Initial value
000040 <sub>H</sub>	IBSR	I <sup>2</sup> C bus status register	R	I <sup>2</sup> C interface* <sup>6</sup>	00000000 <sub>B</sub>
000041 <sub>H</sub>	IBCR	I <sup>2</sup> C bus control register	R/W		00000000 <sub>B</sub>
000042 <sub>H</sub>	ICCR	I <sup>2</sup> C bus clock control register	R/W		-- 0XXXXX <sub>B</sub>
000043 <sub>H</sub>	IADR	I <sup>2</sup> C bus address register	R/W		-XXXXXXX <sub>B</sub>
000044 <sub>H</sub>	IDAR	I <sup>2</sup> C bus data register	R/W		XXXXXXXX <sub>B</sub>
000045 <sub>H</sub> to 00004F <sub>H</sub>	(Vacancy)* <sup>3</sup>				
000050 <sub>H</sub>	TCCR	Free-run timer control register	R/W!	24-bit free-run timer	11000000 <sub>B</sub>
000051 <sub>H</sub>					-- 111111 <sub>B</sub>
000052 <sub>H</sub>	ICC	ICU control register	R/W	Input capture (ICU)	00000000 <sub>B</sub>
000053 <sub>H</sub>					00000000 <sub>B</sub>
000054 <sub>H</sub>	TCRL	Free-run timer lower data register	R	24-bit free-run timer	00000000 <sub>B</sub>
000055 <sub>H</sub>					00000000 <sub>B</sub>
000056 <sub>H</sub>	TCRH	Free-run timer upper data register	R		00000000 <sub>B</sub>
000057 <sub>H</sub>					00000000 <sub>B</sub>
000058 <sub>H</sub>	CCR00	OCU control register 00	R/W	Output compare (OCU) (unit 0)	11110000 <sub>B</sub>
000059 <sub>H</sub>					---- 0000 <sub>B</sub>
00005A <sub>H</sub>	CCR01	OCU control register 01	R/W		---- 0000 <sub>B</sub>
00005B <sub>H</sub>					00000000 <sub>B</sub>
00005C <sub>H</sub>	CCR10	OCU control register 10	R/W	Output compare (OCU) (unit 1)	11110000 <sub>B</sub>
00005D <sub>H</sub>					---- 0000 <sub>B</sub>
00005E <sub>H</sub>	CCR11	OCU control register 11	R/W		---- 0000 <sub>B</sub>
00005F <sub>H</sub>					00000000 <sub>B</sub>
000060 <sub>H</sub>	ICDR0L	ICU lower data register 0	R	Input capture (ICU)	XXXXXXXX <sub>B</sub>
000061 <sub>H</sub>					XXXXXXXX <sub>B</sub>
000062 <sub>H</sub>	ICDR0H	ICU upper data register 0	R		XXXXXXXX <sub>B</sub>
000063 <sub>H</sub>					00000000 <sub>B</sub>
000064 <sub>H</sub>	ICDR1L	ICU lower data register 1	R		XXXXXXXX <sub>B</sub>
000065 <sub>H</sub>					XXXXXXXX <sub>B</sub>
000066 <sub>H</sub>	ICDR1H	ICU upper data register 1	R		XXXXXXXX <sub>B</sub>
000067 <sub>H</sub>					00000000 <sub>B</sub>
000068 <sub>H</sub>	ICDR2L	ICU lower data register 2	R	XXXXXXXX <sub>B</sub>	
000069 <sub>H</sub>				XXXXXXXX <sub>B</sub>	

(Continued)

# MB90670/675 Series

Address	Abbreviated register name	Register name	Read/write	Resource name	Initial value	
00006AH	ICDR2H	ICU upper data register 2	R	Input capture (ICU)	XXXXXXXX <sub>B</sub>	
00006BH					00000000 <sub>B</sub>	
00006CH	ICDR3L	ICU lower data register 3	R		XXXXXXXX <sub>B</sub>	
00006DH					XXXXXXXX <sub>B</sub>	
00006EH	ICDR3H	ICU upper data register 3	R		XXXXXXXX <sub>B</sub>	
00006FH					00000000 <sub>B</sub>	
000070H	CPR00L	OCU compare lower data register 0	R/W	Output compare (OCU) (unit 0)	00000000 <sub>B</sub>	
000071H					00000000 <sub>B</sub>	
000072H	CPR00H	OCU compare upper data register 0	R/W		00000000 <sub>B</sub>	
000073H					00000000 <sub>B</sub>	
000074H	CPR01L	OCU compare lower data register 1	R/W		00000000 <sub>B</sub>	
000075H					00000000 <sub>B</sub>	
000076H	CPR01H	OCU compare upper data register 1	R/W		00000000 <sub>B</sub>	
000077H					00000000 <sub>B</sub>	
000078H	CPR02L	OCU compare lower data register 2	R/W		00000000 <sub>B</sub>	
000079H					00000000 <sub>B</sub>	
00007AH	CPR02H	OCU compare upper data register 2	R/W		00000000 <sub>B</sub>	
00007BH					00000000 <sub>B</sub>	
00007CH	CPR03L	OCU compare lower data register 3	R/W		00000000 <sub>B</sub>	
00007DH					00000000 <sub>B</sub>	
00007EH	CPR03H	OCU compare upper data register 3	R/W		00000000 <sub>B</sub>	
00007FH					00000000 <sub>B</sub>	
000080H	CPR04L	OCU compare lower data register 4	R/W		Output compare (OCU) (unit 1)	00000000 <sub>B</sub>
000081H						00000000 <sub>B</sub>
000082H	CPR04H	OCU compare upper data register 4	R/W	00000000 <sub>B</sub>		
000083H				00000000 <sub>B</sub>		
000084H	CPR05L	OCU compare lower data register 5	R/W	00000000 <sub>B</sub>		
000085H				00000000 <sub>B</sub>		
000086H	CPR05H	OCU compare upper data register 5	R/W	00000000 <sub>B</sub>		
000087H				00000000 <sub>B</sub>		
000088H	CPR06L	OCU compare lower data register 6	R/W	00000000 <sub>B</sub>		
000089H				00000000 <sub>B</sub>		
00008AH	CPR06H	OCU compare upper data register 6	R/W	00000000 <sub>B</sub>		
00008BH				00000000 <sub>B</sub>		

(Continued)

# MB90670/675 Series

Address	Abbreviated register name	Register name	Read/write	Resource name	Initial value
00008C <sub>H</sub>	CPR07L	OCU compare lower data register 7	R/W	Output compare (OCU) (unit 1)	00000000 <sub>B</sub>
00008D <sub>H</sub>					00000000 <sub>B</sub>
00008E <sub>H</sub>	CPR07H	OCU compare upper data register 7	R/W		00000000 <sub>B</sub>
00008F <sub>H</sub>					00000000 <sub>B</sub>
000090 <sub>H</sub> to 00009E <sub>H</sub>	(System reservation area)* <sup>1</sup>				
00009F <sub>H</sub>	DIRR	Delayed interrupt factor generation/cancellation register	R/W	Delayed interrupt generation module	-----0 <sub>B</sub>
0000A0 <sub>H</sub>	LPMCR	Low-power consumption mode control register	R/W!	Low-power consumption (stand-by) mode	00011000 <sub>B</sub>
0000A1 <sub>H</sub>	CKSCR	Clock selection register	R/W!	Low-power consumption (stand-by) mode	11111100 <sub>B</sub>
0000A2 <sub>H</sub> to 0000A4 <sub>H</sub>	(Vacancy)* <sup>3</sup>				
0000A5 <sub>H</sub>	ARSR	Automatic ready function select register	W	External bus pin	0011 -- 00 <sub>B</sub>
0000A6 <sub>H</sub>	HACR	Upper address control register	W	External bus pin	---- 0000 <sub>B</sub>
0000A7 <sub>H</sub>	EPCR	Bus control signal select register	W	External bus pin	0000*00- <sub>B</sub>
0000A8 <sub>H</sub>	WDTC	Watchdog timer control register	R/W!	Watchdog timer	XXXXX111 <sub>B</sub>
0000A9 <sub>H</sub>	TBTC	Timebase timer control register	R/W!	Timebase timer	1 -- 00100 <sub>B</sub>
0000AA <sub>H</sub> to 0000AF <sub>H</sub>	(Vacancy)* <sup>3</sup>				
0000B0 <sub>H</sub>	ICR00	Interrupt control register 00	R/W!	Interrupt controller	00000111 <sub>B</sub>
0000B1 <sub>H</sub>	ICR01	Interrupt control register 01	R/W!		00000111 <sub>B</sub>
0000B2 <sub>H</sub>	ICR02	Interrupt control register 02	R/W!		00000111 <sub>B</sub>
0000B3 <sub>H</sub>	ICR03	Interrupt control register 03	R/W!		00000111 <sub>B</sub>
0000B4 <sub>H</sub>	ICR04	Interrupt control register 04	R/W!		00000111 <sub>B</sub>
0000B5 <sub>H</sub>	ICR05	Interrupt control register 05	R/W!		00000111 <sub>B</sub>
0000B6 <sub>H</sub>	ICR06	Interrupt control register 06	R/W!		00000111 <sub>B</sub>
0000B7 <sub>H</sub>	ICR07	Interrupt control register 07	R/W!		00000111 <sub>B</sub>
0000B8 <sub>H</sub>	ICR08	Interrupt control register 08	R/W!		00000111 <sub>B</sub>
0000B9 <sub>H</sub>	ICR09	Interrupt control register 09	R/W!		00000111 <sub>B</sub>

(Continued)

# MB90670/675 Series

(Continued)

Address	Abbreviated register name	Register name	Read/write	Resource name	Initial value
0000BA <sub>H</sub>	ICR10	Interrupt control register 10	R/W!	Interrupt controller	00000111 <sub>B</sub>
0000BB <sub>H</sub>	ICR11	Interrupt control register 11	R/W!		00000111 <sub>B</sub>
0000BC <sub>H</sub>	ICR12	Interrupt control register 12	R/W!		00000111 <sub>B</sub>
0000BD <sub>H</sub>	ICR13	Interrupt control register 13	R/W!		00000111 <sub>B</sub>
0000BE <sub>H</sub>	ICR14	Interrupt control register 14	R/W!		00000111 <sub>B</sub>
0000BF <sub>H</sub>	ICR15	Interrupt control register 15	R/W!		00000111 <sub>B</sub>
0000C0 <sub>H</sub> to 0000FF <sub>H</sub>	(External area)*2				

## Descriptions for read/write

R/W: Readable and writable

R: Read only

W: Write only

R/W!: Bits for reading operation only or writing operation only are included. Refer to the register lists for specific resource for detailed information.

## Descriptions for initial value

0 : The initial value of this bit is "0".

1 : The initial value of this bit is "1".

\* : The initial value of this bit is "1" or "0" (decided by levels on pins of MD0 through MD2).

X : The initial value of this bit is indeterminate.

– : This bit is not used. The initial value is indeterminate.

\*1: Access prohibited.

\*2: This area is the only external access area having an address of 0000FF<sub>H</sub> or lower. An access operation to this area is handled as that to external I/O area.

\*3: The area corresponding to the "(Vacancy)" on the I/O map is reserved, and accessing operation to this area is handled as that to internal area. No access signal to external devices are generated.

\*4: Only bit 15 is writable. Reading bit 10 through bit 15 returns "0" as a reading result.

\*5: In the MB90670 series, P81 through P86, P90, P91, PA0 through PA7, PB0 through PB2 are not present. For this reason, bits corresponding to these pins are not used.

\*6: The MB90670 series does not have the I<sup>2</sup>C interface. For this reason, this area is "(Vacancy)" in the MB90670 series.

Note: For bits that is only allowed to program, the initial value set by the reset operation is listed as an initial value. Note that the values are different from reading results.

For LPMCR/CKSCR/WDTC, there are cases where initialization is performed or not performed, depending on the types of the reset. However initial value for resets that initializes the value are listed.



# MB90670/675 Series

(Continued)

Interrupt source	EI <sup>2</sup> OS support	Interrupt vector			Interrupt control register		Priority*4
		Number	Address	Address	ICR	Address	
UART1 (SCI) transmission complete	△	# 35	23 <sub>H</sub>	FFFF70 <sub>H</sub>	ICR12	0000BC <sub>H</sub> *2	High ↑ ↓ Low
UART0 transmission complete	△	# 36	24 <sub>H</sub>	FFFF6C <sub>H</sub>			
UART1 (SCI) reception complete	○	# 37	25 <sub>H</sub>	FFFF68 <sub>H</sub>	ICR13	0000BD <sub>H</sub> *2	
I <sup>2</sup> C interface*1	×	# 38	26 <sub>H</sub>	FFFF64 <sub>H</sub>			
UART0 reception complete	◎	# 39	27 <sub>H</sub>	FFFF60 <sub>H</sub>	ICR14	0000BE <sub>H</sub>	
Delayed interrupt generation module	×	# 42	2A <sub>H</sub>	FFFF54 <sub>H</sub>	ICR15	0000BF <sub>H</sub>	

○ : Can be used

×

◎ : Can be used. With EI<sup>2</sup>OS stop function.

△ : Can be used if interrupt request using ICR are not commonly used.

\*1: In MB90670 series, this interrupt vector is not used because the series does not have the I<sup>2</sup>C interface.

\*2: • Interrupt levels for peripherals that commonly use the ICR register are in the same level.

- When the extended intelligent I/O service (EI<sup>2</sup>OS) is specified in a peripheral device commonly using the ICR register, only one of the functions can be used.
- When the extended intelligent I/O service (EI<sup>2</sup>OS) is specified for one of the peripheral functions, interrupts can not be used on the other function.

\*3: Only 16-bit reload timer conforms to the extended intelligent I/O service (EI<sup>2</sup>OS). Because the 8/16-bit PPG timer does not conform to the extended intelligent I/O service (EI<sup>2</sup>OS), disable interrupts of the 8/16-bit PPG timer when using the extended intelligent I/O service (EI<sup>2</sup>OS) in the 16-bit reload timer.

\*4: The level shows priority of same level of interrupt invoked simultaneously.

## ■ PERIPHERALS

### 1. I/O Port

#### (1) Input/output Port

Port 0 to 4, 6, 8, A, and B are general-purpose I/O ports having a combined function as an external bus pin and a resource input. The input output ports function as general-purpose I/O port only in the single-chip mode. In the external bus mode, the ports are configured as external bus pins, and part of pins for port 3 can be configured as general-purpose I/O port by setting the bus control signal select register (ECSR). Each pin corresponding to upper 4-bit of the port 2 can be switched between a resource and a port bitwise.

Only MB90675 series has port A and port B.

- Operation as output port

The pin is configured as an output port by setting the corresponding bit of the DDR register to "1".

Writing data to PDR register when the port is configured as output, the data is retained in the output latch in the PDR and directly output to the pin.

The value of the pin (the same value retained in the output latch of PDR) can be read out by reading the PDR register.

Note: When a read-modify-write instruction (e.g. bit set instruction) is performed to the port data register, the destination bit of the operation is set to the specified value, not affecting the bits configured by the DDR register for output, however, values of bits configured by the DDR register as inputs are changed because input values to the pins are written into the output latch. To avoid this situation, configure the pins by the DDR register as output after writing output data to the PDR register when configuring the bit used as input as outputs.

- Operation as input port

The pin is configured as an input by setting the corresponding bit of the DDR register to "0".

When the pin is configured as an input, the output buffer is turned-off and the pin is put into a high-impedance status.

When a data is written into the PDR register, the data is retained in the output latch of the PDR, but pin outputs are unaffected.

Reading the PDR register reads out the pin level ("0" or "1")

- Block diagram

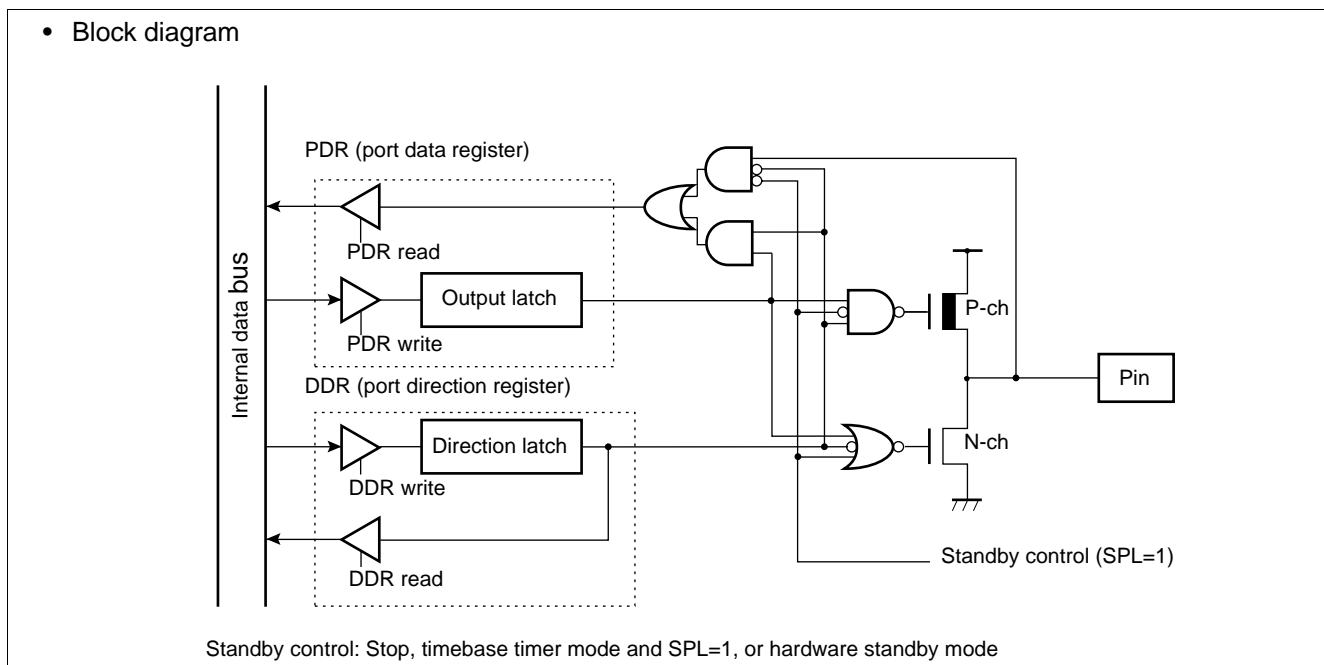

# MB90670/675 Series

## (2) N-ch Open-drain Port

Port 5 and port 9 are general-purpose I/O ports having a combined function as resource input/output. Each pin can be switched between resource and port bitwise.

Only MB90675 series has port 9.

- Operation as output port

When a data is written into the PDR register, the data is latched to the output latch of PDR. When the output latch value is set to "0", the output transistor is turned on and the pin status is put into an "L" level output, while writing "1" turns off the transistor and put the pin in a high-impedance status.

If the output pin is pulled-up, setting output latch value to "1" puts the pin in the pull-up status.

Reading the PDR register returns the pin value (same as the output latch value in the PDR).

Note: Execution of a read-modify-write instruction (e.g. bit set instruction) reads out the output latch value rather than the pin value, leaving output latch that is not manipulated unchanged.

- Operation as input port

Setting corresponding bit of the PDR register to "1" turns off the output transistor and the pin is put into a high-impedance status.

Reading the PDR register returns the pin level ("0" or "1").

- Block diagram of port 5

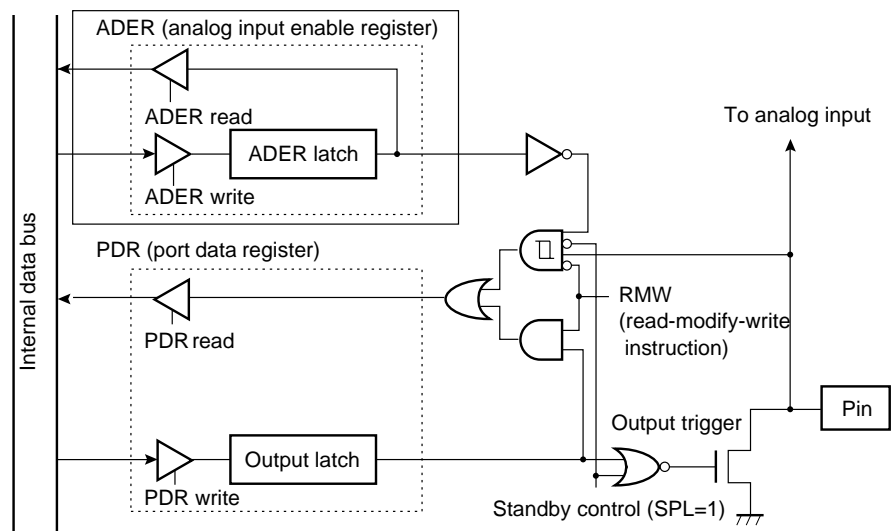

Standby control: Stop, timebase timer mode and SPL=1, or hardware standby mode

- Block diagram of port 9

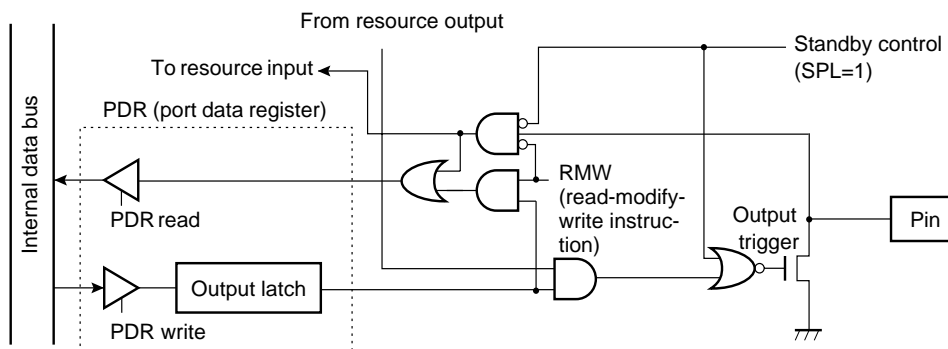

Standby control: Stop, timebase timer mode and SPL=1, or hardware standby mode



## (3) Output Port

Port 7 is a general-purpose output port having a combined function as an output compare (OCU) output. Note that only OCU output can be output when the pin is configured as an output, and it is not used for outputting given data by writing to the data register. Each pin can be switched between an output compare output and a port bitwise.

- Operation as output port (operation of OCU output)

Setting the corresponding bit of the DDR register to "1" configures the pin as an output port. In this case, lower 4-bit of CCR01 and CCR register are output.

When configured as an output, the output buffer is turned on and data retained in the output latch in the PDR of the output compare is output to the pin.

Writing data to DOT bit of the OCU control register (CCR01, CCR11) corresponding to each pin writes data in synchronization to a match operation of the output compare and output to the pin.

Reading the PDR register returns the pin level (same as the output latch value of the PDR).

When output of output compare is enabled, an output value from the output compare can be read out.

- Operation as input port

Setting corresponding bit of the DDR register to "0" configures the pin as input port.

When the pin is configured as an input port, the output buffer is turned off and the pin is put into a high-impedance status.

Reading the PDR register returns the pin level ("0" or "1").

- Block diagram

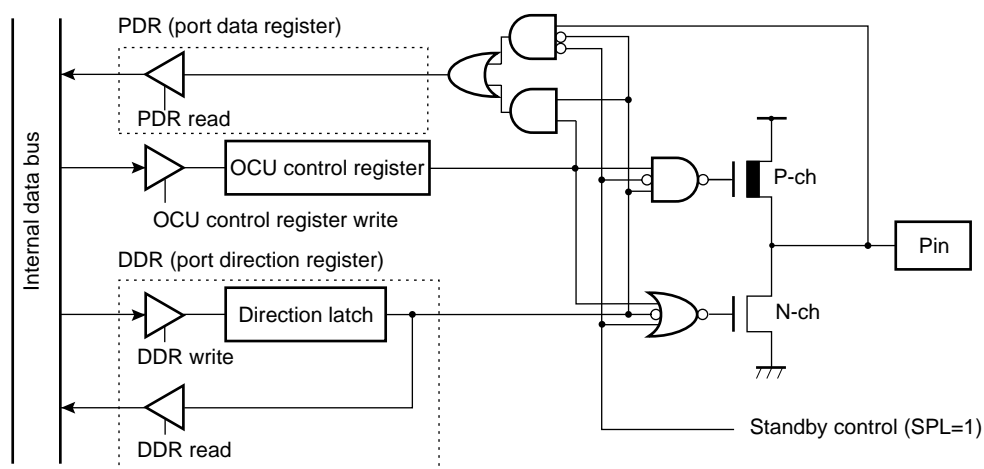

Standby control: Stop, timebase timer mode and SPL=1, or hardware standby mode

# MB90670/675 Series

## (4) Register Configuration

Address	bit 15	bit 14	bit 13	bit 12	bit 11	bit 10	bit 9	bit 8	bit 7	bit 6	bit 5	bit 4	bit 3	bit 2	bit 1	bit 0		
000000H	(PDR1)							P07	P06	P05	P04	P03	P02	P01	P00	(PDR0)		Port 0 data register (PDR0)
								R/W	R/W	R/W	R/W	R/W	R/W	R/W	R/W	R/W		
Address	bit 15	bit 14	bit 13	bit 12	bit 11	bit 10	bit 9	bit 8	bit 7	bit 6	bit 5	bit 4	bit 3	bit 2	bit 1	bit 0		
000001H	P17	P16	P15	P14	P13	P12	P11	P10	(PDR0)							Port 1 data register (PDR1)		
	R/W	R/W	R/W	R/W	R/W	R/W	R/W	R/W	R/W									
Address	bit 15	bit 14	bit 13	bit 12	bit 11	bit 10	bit 9	bit 8	bit 7	bit 6	bit 5	bit 4	bit 3	bit 2	bit 1	bit 0		
000002H	(PDR3)							P27	P26	P25	P24	P23	P22	P21	P20	(PDR2)		Port 2 data register (PDR2)
								R/W	R/W	R/W	R/W	R/W	R/W	R/W	R/W	R/W		
Address	bit 15	bit 14	bit 13	bit 12	bit 11	bit 10	bit 9	bit 8	bit 7	bit 6	bit 5	bit 4	bit 3	bit 2	bit 1	bit 0		
000003H	P37	P36	P35	P34	P33	P32	P31	P30	(PDR2)							Port 3 data register (PDR3)		
	R/W	R/W	R/W	R/W	R/W	R/W	R/W	R/W	R/W									
Address	bit 15	bit 14	bit 13	bit 12	bit 11	bit 10	bit 9	bit 8	bit 7	bit 6	bit 5	bit 4	bit 3	bit 2	bit 1	bit 0		
000004H	(PDR5)							P47	P46	P45	P44	P43	P42	P41	P40	(PDR4)		Port 4 data register (PDR4)
								R/W	R/W	R/W	R/W	R/W	R/W	R/W	R/W	R/W		
Address	bit 15	bit 14	bit 13	bit 12	bit 11	bit 10	bit 9	bit 8	bit 7	bit 6	bit 5	bit 4	bit 3	bit 2	bit 1	bit 0		
000005H	P57	P56	P55	P54	P53	P52	P51	P50	(PDR4)							Port 5 data register (PDR5)		
	R/W	R/W	R/W	R/W	R/W	R/W	R/W	R/W	R/W									
Address	bit 15	bit 14	bit 13	bit 12	bit 11	bit 10	bit 9	bit 8	bit 7	bit 6	bit 5	bit 4	bit 3	bit 2	bit 1	bit 0		
000006H	(PDR7)							P67	P66	P65	P64	P63	P62	P61	P60	(PDR6)		Port 6 data register (PDR6)
								R/W	R/W	R/W	R/W	R/W	R/W	R/W	R/W	R/W		
Address	bit 15	bit 14	bit 13	bit 12	bit 11	bit 10	bit 9	bit 8	bit 7	bit 6	bit 5	bit 4	bit 3	bit 2	bit 1	bit 0		
000007H	P77	P76	P75	P74	P73	P72	P71	P70	(PDR6)							Port 7 data register (PDR7)		
	R/W	R/W	R/W	R/W	R/W	R/W	R/W	R/W	R/W									
Address	bit 15	bit 14	bit 13	bit 12	bit 11	bit 10	bit 9	bit 8	bit 7	bit 6	bit 5	bit 4	bit 3	bit 2	bit 1	bit 0		
000008H	(PDR9)							—	P86	P85	P84	P83	P82	P81	P80	(PDR8)		Port 8 data register (PDR8)
								R/W	R/W	R/W	R/W	R/W	R/W	R/W	R/W	R/W		
Address	bit 15	bit 14	bit 13	bit 12	bit 11	bit 10	bit 9	bit 8	bit 7	bit 6	bit 5	bit 4	bit 3	bit 2	bit 1	bit 0		
000009H	—	—	—	—	—	—	P91	P90	(PDR8)							Port 9 data register (PDR9)		
	R/W	R/W	R/W	R/W	R/W	R/W	R/W	R/W	R/W									
Address	bit 15	bit 14	bit 13	bit 12	bit 11	bit 10	bit 9	bit 8	bit 7	bit 6	bit 5	bit 4	bit 3	bit 2	bit 1	bit 0		
00000AH	(PDRB)							PA7	PA6	PA5	PA4	PA3	PA2	PA1	PA0	(PDRB)		Port A data register (PDRB)
								R/W	R/W	R/W	R/W	R/W	R/W	R/W	R/W	R/W		
Address	bit 15	bit 14	bit 13	bit 12	bit 11	bit 10	bit 9	bit 8	bit 7	bit 6	bit 5	bit 4	bit 3	bit 2	bit 1	bit 0		
00000BH	—	—	—	—	—	PB2	PB1	PB0	(PDRB)							Port B data register (PDRB)		
	R/W	R/W	R/W	R/W	R/W	R/W	R/W	R/W	R/W									

(Continued)

# MB90670/675 Series

(Continued)

Address	bit-15	.....	bit 8	bit 7	bit 6	bit 5	bit 4	bit 3	bit 2	bit 1	bit 0	
000010 <sub>H</sub>	(DDR1)			P07	P06	P05	P04	P03	P02	P01	P00	Port 0 data direction register (DDR0)
				R/W	R/W	R/W	R/W	R/W	R/W	R/W	R/W	
Address	bit 15	bit 14	bit 13	bit 12	bit 11	bit 10	bit 9	bit 8	bit 7	.....	bit 0	
000011 <sub>H</sub>	P17	P16	P15	P14	P13	P12	P11	P10	(DDR0)			Port 1 data direction register (DDR1)
	R/W	R/W	R/W	R/W	R/W	R/W	R/W	R/W				
Address	bit 15	.....	bit 8	bit 7	bit 6	bit 5	bit 4	bit 3	bit 2	bit 1	bit 0	
000012 <sub>H</sub>	(DDR3)			P27	P26	P25	P24	P23	P22	P21	P20	Port 2 data direction register (DDR2)
				R/W	R/W	R/W	R/W	R/W	R/W	R/W	R/W	
Address	bit 15	bit 14	bit 13	bit 12	bit 11	bit 10	bit 9	bit 8	bit 7	.....	bit 0	
000013 <sub>H</sub>	P37	P36	P35	P34	P33	P32	P31	P30	(DDR2)			Port 3 data direction register (DDR3)
	R/W	R/W	R/W	R/W	R/W	R/W	R/W	R/W				
Address	bit 15	.....	bit 8	bit 7	bit 6	bit 5	bit 4	bit 3	bit 2	bit 1	bit 0	
000014 <sub>H</sub>	(ADER)			P47	P46	P45	P44	P43	P42	P41	P40	Port 4 data direction register (DDR4)
				R/W	R/W	R/W	R/W	R/W	R/W	R/W	R/W	
Address	bit 15	bit 14	bit 13	bit 12	bit 11	bit 10	bit 9	bit 8	bit 7	.....	bit 0	
000015 <sub>H</sub>	P57	P56	P55	P54	P53	P52	P51	P50	(DDR4)			Analog input enable register (ADER)
	R/W	R/W	R/W	R/W	R/W	R/W	R/W	R/W				
Address	bit 15	.....	bit 8	bit 7	bit 6	bit 5	bit 4	bit 3	bit 2	bit 1	bit 0	
000016 <sub>H</sub>	(DDR7)			P67	P66	P65	P64	P63	P62	P61	P60	Port 6 data direction register (DDR6)
				R/W	R/W	R/W	R/W	R/W	R/W	R/W	R/W	
Address	bit 15	bit 14	bit 13	bit 12	bit 11	bit 10	bit 9	bit 8	bit 7	.....	bit 0	
000017 <sub>H</sub>	P77	P76	P75	P74	P73	P72	P71	P70	(DDR6)			Port 7 data direction register (DDR7)
	R/W	R/W	R/W	R/W	R/W	R/W	R/W	R/W				
Address	bit 15	.....	bit 8	bit 7	bit 6	bit 5	bit 4	bit 3	bit 2	bit 1	bit 0	
000018 <sub>H</sub>	(Vacancy)			—	P86	P85	P84	P83	P82	P81	P80	Port 8 data direction register (DDR8)
				R/W	R/W	R/W	R/W	R/W	R/W	R/W	R/W	
Address	bit 15	.....	bit 8	bit 7	bit 6	bit 5	bit 4	bit 3	bit 2	bit 1	bit 0	
00001A <sub>H</sub>	(DDR <sub>B</sub> )			PA7	PA6	PA5	PA4	PA3	PA2	PA1	PA0	Port A data direction register (DDRA)
				R/W	R/W	R/W	R/W	R/W	R/W	R/W	R/W	
Address	bit 15	bit 14	bit 13	bit 12	bit 11	bit 10	bit 9	bit 8	bit 7	.....	bit 0	
00001B <sub>H</sub>	—	—	—	—	—	PB2	PB1	PB0	(DDRA)			Port B data direction register (DDRB)
	R/W	R/W	R/W	R/W	R/W	R/W	R/W	R/W				

Note: Only MB90675 series has P81 through P86, P90, PA0 through PA7, and PB0 through PB2, and MB90670 series does not have such pins.

# MB90670/675 Series

## 2. Timebase Timer

The timebase timer is a 18-bit free run counter (timebase counter) for counting up in synchronization to the internal count clock (divided-by-2 of oscillation) with an interval timer function for selecting an interval time from four types of  $2^{12}/\text{HCLK}$ ,  $2^{14}/\text{HCLK}$ ,  $2^{16}/\text{HCLK}$ , and  $2^{19}/\text{HCLK}$ .

The timebase timer also has a function for supplying operating clocks for the timer output for the oscillation stabilization time or the watchdog timer etc.

### (1) Register Configuration

- Timebase timer control register (TBTC)

Address	bit 15	bit 14	bit 13	bit 12	bit 11	bit 10	bit 9	bit 8	bit 7	.....	bit 0	Initial value
0000A9 <sub>H</sub>	RESV	—	—	TBIE	TBOF	TBR	TBC1	TBC0	(WDTC)			1--00100 <sub>B</sub>
	R/W	—	—	R/W	R/W	W	R/W	R/W				

R/W: Readable and writable  
 W : Read only  
 — : Unused

### (2) Block Diagram

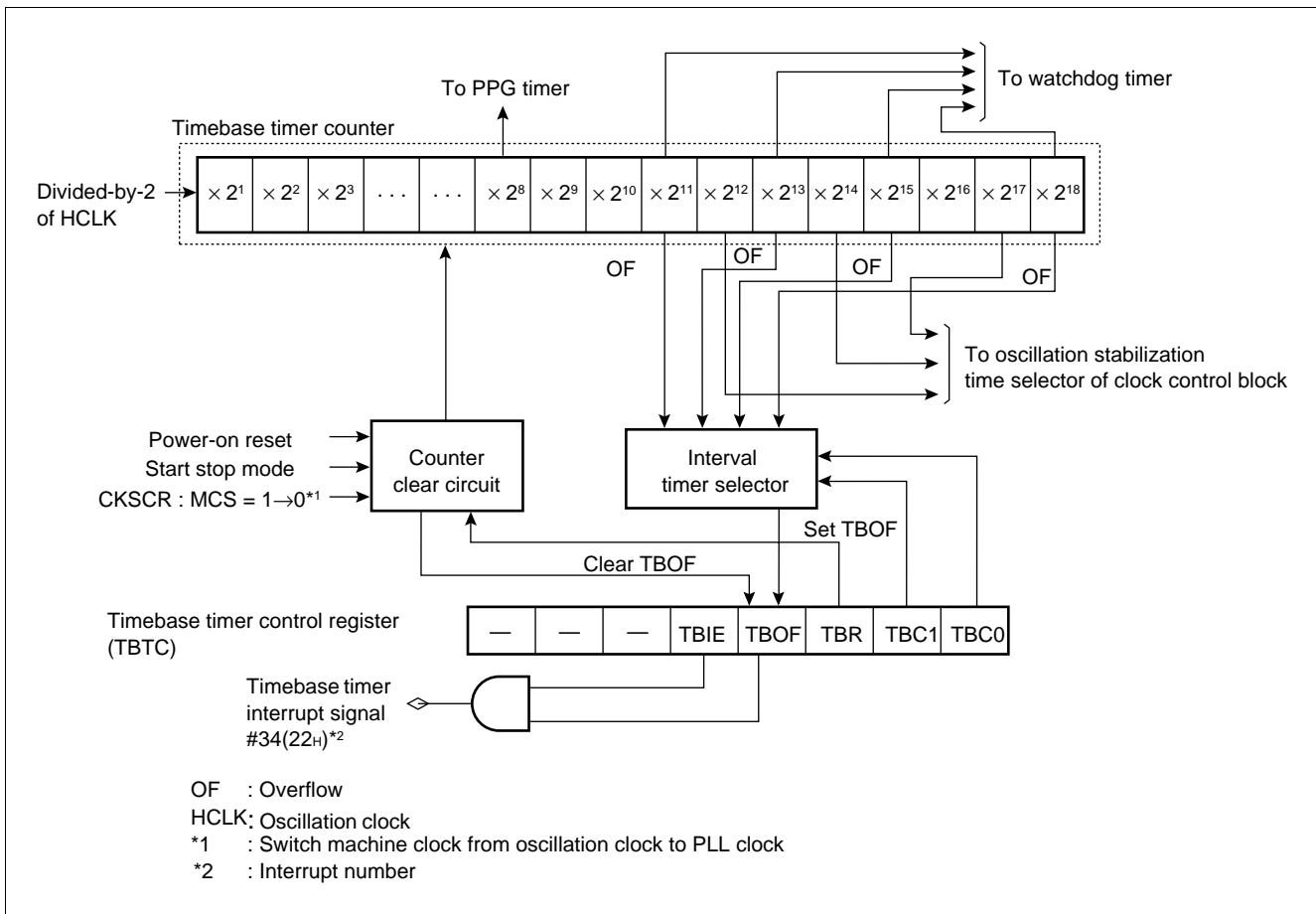

### 3. Watchdog Timer

The watchdog timer is a 2-bit counter operating with an output of the timebase timer and resets the CPU when the counter is not cleared for a preset period of time.

#### (1) Register Configuration

- Watchdog timer control register (WDTC)

Address	bit 15	.....	bit 8	bit 7	bit 6	bit 5	bit 4	bit 3	bit 2	bit 1	bit 0	
0000A8 <sub>H</sub>	(TBTC)			PONR	STBR	WRST	ERST	SRST	WTE	WT1	WT0	Initial value XXXXX111 <sub>B</sub>
				R	R	R	R	R	W	W	W	

R : Read only  
 W : Write only  
 X : Indeterminate

#### (2) Block Diagram

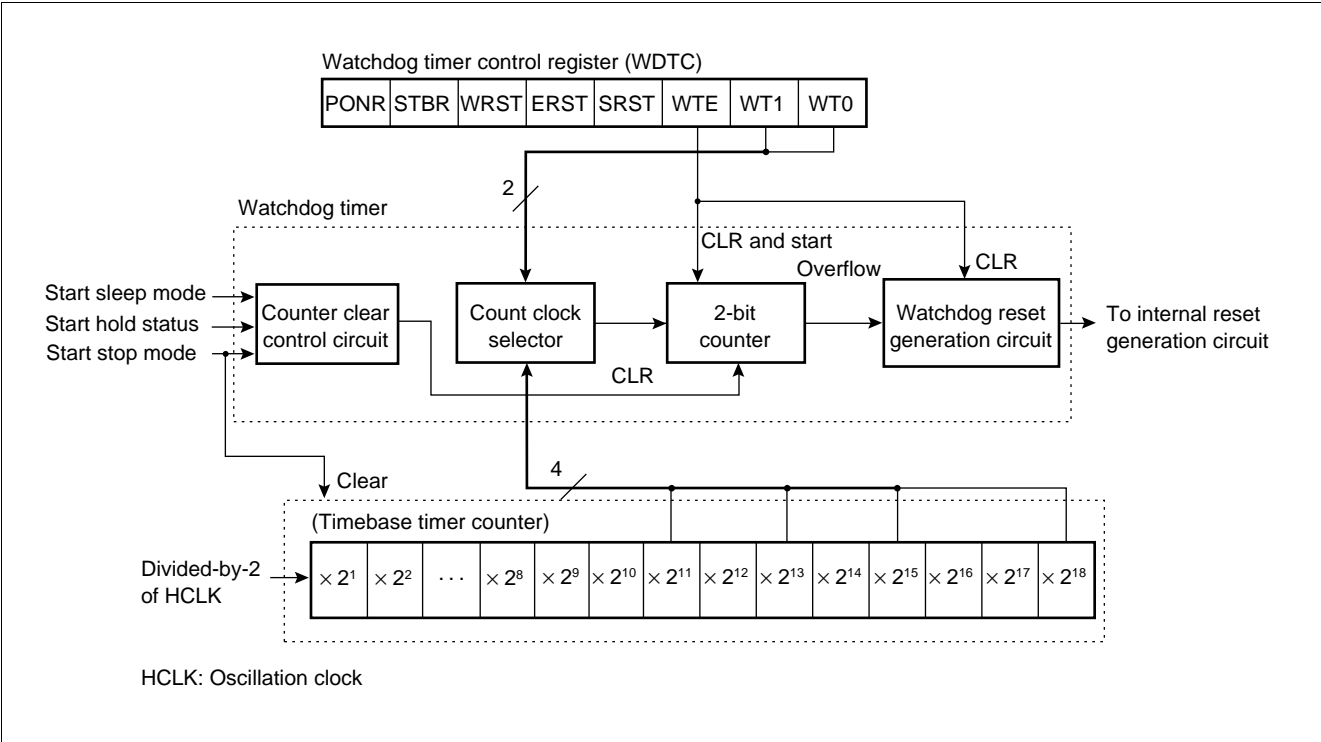

# MB90670/675 Series

## 4. 8/16-bit PPG Timer

The 8/16-bit PPG timer is 2-channel reload timer module for outputting pulse having given frequencies/duty ratios.

The two modules performs the following operation by combining functions.

- 8-bit PPG output 2-channel independent operation mode  
This is a mode for operating independent 2-channel 8-bit PPG timer, in which PPG0 and PPG1 pins correspond to outputs from PPG0 and PPG1 respectively.
- 16-bit PPG output operation mode  
In this mode, PPG0 and PPG1 are combined to be operated as a 1-channel 8/16-bit PPG timer operating as a 16-bit timer. Because PPG0 and PPG1 outputs are reversed by an underflow from PPG1 outputting the same output pulses from PPG0 and PPG1 pins.
- 8 + 8-bit PPG output operation mode  
In this mode, PPG0 is operated as an 8-bit prescaler, in which an underflow output of PPG0 is used as a clock source for PPG1. A toggle output of PPG0 and PPG output of PPG1 are output from PPG0 and PPG1 respectively.

The module can also be used as a D/A converter with an external add-on circuit.

### (1) Register Configuration

• PPG0 operating mode control register (PPGC0)										Initial value							
Address	bit 15	bit 14	bit 13	bit 12	bit 11	bit 10	bit 9	bit 8	bit 7	bit 6	bit 5	bit 4	bit 3	bit 2	bit 1	bit 0	0 - 000001 <sub>B</sub>
000030 <sub>H</sub>	(PPGC1)			PEN0	—	POE0	PIE0	PUF0	PCM1	PCM0	RESV						
				R/W	—	R/W	R/W	R/W	R/W	R/W	R/W						
• PPG1 operating mode control register (PPGC 1)										Initial value							
Address	bit 15	bit 14	bit 13	bit 12	bit 11	bit 10	bit 9	bit 8	bit 7	bit 6	bit 5	bit 4	bit 3	bit 2	bit 1	bit 0	00000001 <sub>B</sub>
000031 <sub>H</sub>	PEN1	PCS1	POE1	PIE1	PUF1	MD1	MD0	RESV	(PPGC0)								
	R/W	R/W	R/W	R/W	R/W	R/W	R/W	R/W									
• PPG reload register (PRL0,PRLH0,PRL1,PRLH1)										Initial value							
Address	bit 15	bit 14	bit 13	bit 12	bit 11	bit 10	bit 9	bit 8	bit 7	bit 6	bit 5	bit 4	bit 3	bit 2	bit 1	bit 0	XXXXXXXX <sub>B</sub>
PRLH0:000035 <sub>H</sub> PRLH1:000037 <sub>H</sub>	(PRLH0,PRLH1)																
				R/W	R/W	R/W	R/W	R/W	R/W	R/W	R/W	R/W	R/W	R/W	R/W	R/W	
Address	bit 15	bit 14	bit 13	bit 12	bit 11	bit 10	bit 9	bit 8	bit 7	bit 6	bit 5	bit 4	bit 3	bit 2	bit 1	bit 0	Initial value
PRL0:000034 <sub>H</sub> PRL1:000036 <sub>H</sub>									(PRL0,PRL1)								XXXXXXXX <sub>B</sub>
	R/W	R/W	R/W	R/W	R/W	R/W	R/W	R/W									

R/W : Readable and writable  
 — : Unused  
 X : Indeterminate

# MB90670/675 Series

## (2) Block Diagram

- Block diagram of 8/16-bit PPG timer 0

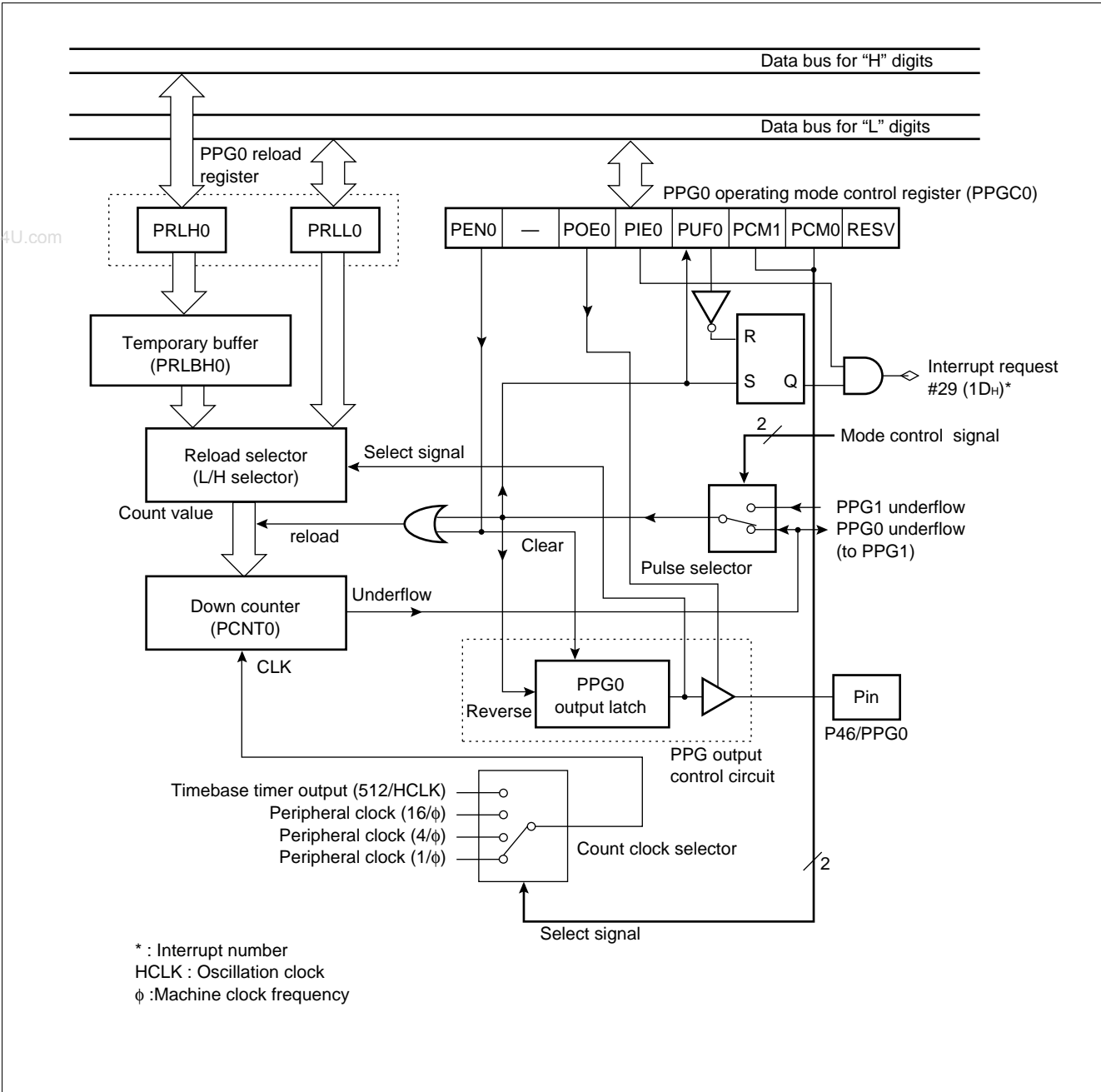

# MB90670/675 Series

- Block diagram of 8/16-bit PPG timer 1

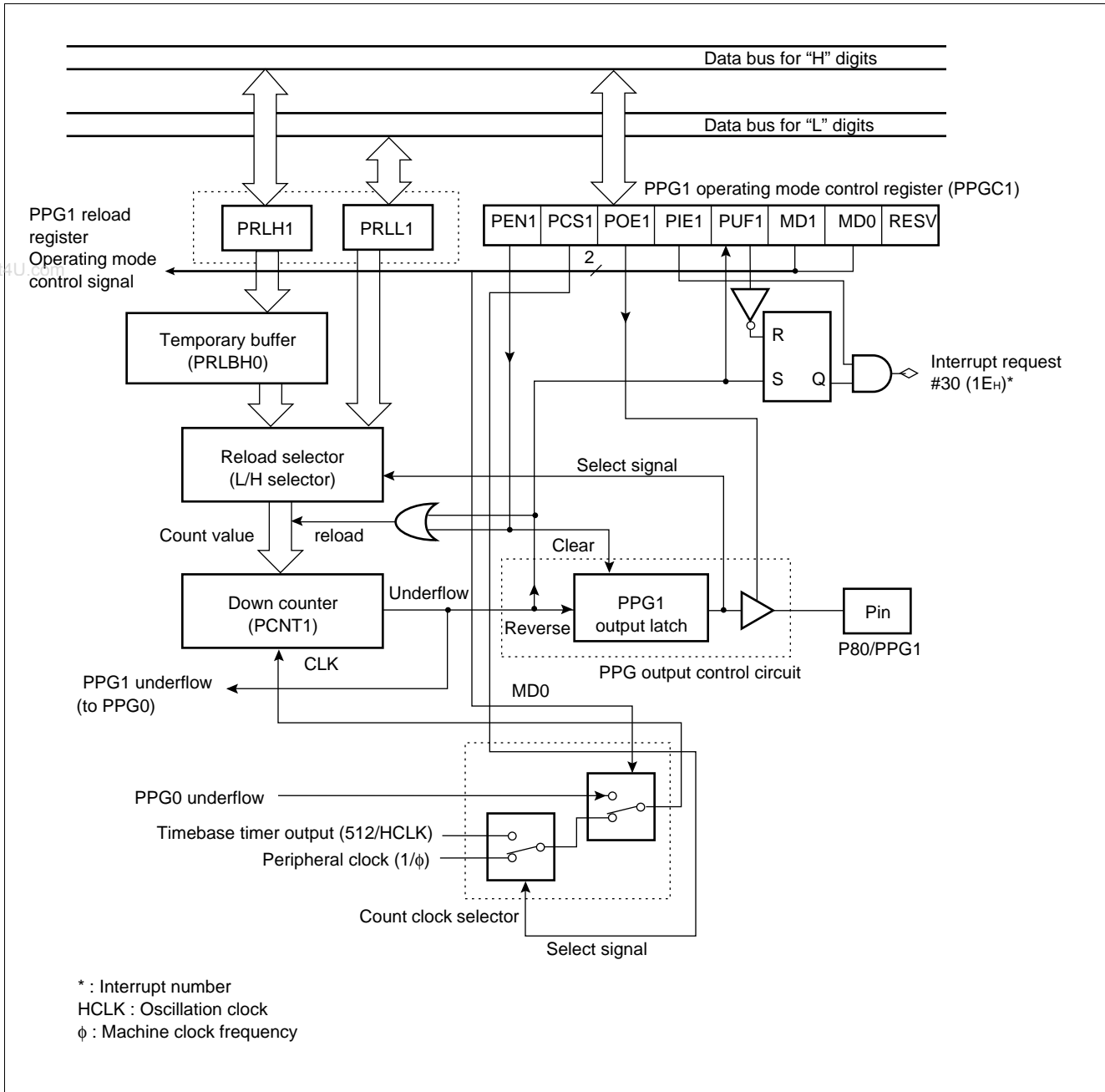



## 5. 16-bit Reload Timer

The 16-bit reload timer has an internal clock mode for counting down in synchronization to three types of internal clocks and an event count mode for counting down detecting a given edge of the pulse input to the external bus pin, and either of the two functions can be selectively used.

For this timer, an “underflow” is defined as the counter value of “0000<sub>H</sub>” to “FFFF<sub>H</sub>”. According to this definition, an underflow occurs after [reload register setting value + 1] counts.

In operating the counter, the reload mode for repeating counting operation after reloading a counter setting value after an underflow or the one-shot mode for stopping the counting operation after an underflow can be selectively used.

Because the timer can generate an interrupt upon an underflow, the timer conforms to the extended intelligent I/O service (EI<sup>2</sup>OS).

The MB90670/675 series has 2 channels of 16-bit reload timers.

### (1) Register Configuration

- Timer control status register upper digits (TMCSR0, TMCSR1 : H)

Address	bit 15	bit 14	bit 13	bit 12	bit 11	bit 10	bit 9	bit 8	bit 7	.....	bit 0	Initial value
TMCSR0:000039 <sub>H</sub> TMCSR1:00003D <sub>H</sub>	—	—	—	—	CSL1	CSL0	MOD2	MOD1	(TMCSR : L)			----0000 <sub>B</sub>
	—	—	—	—	R/W	R/W	R/W	R/W				

- Timer control status register lower digits (TMCSR0, TMCSR1 : L)

Address	bit 15	.....	bit 8	bit 7	bit 6	bit 5	bit 4	bit 3	bit 2	bit 1	bit 0	Initial value
TMCSR0:000038 <sub>H</sub> TMCSR1:00003C <sub>H</sub>	(TMCSR : H)			MOD1	OUTE	OUTL	RELD	INTE	UF	CNTE	TRG	00000000 <sub>B</sub>
				R/W	R/W	R/W	R/W	R/W	R/W	R/W	R/W	

- 16-bit timer register 0, 1 (TMR0, TMR1)

Address	bit 15	bit 14	bit 13	bit 12	bit 11	bit 10	bit 9	bit 8	bit 7	bit 6	bit 5	bit 4	bit 3	bit 2	bit 1	bit 0	Initial value
00003A <sub>H</sub> 00003B <sub>H</sub> 00003E <sub>H</sub> 00003F <sub>H</sub>																	XXXXXXXX <sub>B</sub> XXXXXXXX <sub>B</sub> XXXXXXXX <sub>B</sub> XXXXXXXX <sub>B</sub>
	R	R	R	R	R	R	R	R	R	R	R	R	R	R	R	R	

- 16-bit reload register 0, 1 (TMRL0, TMRL1)

Address	bit 15	bit 14	bit 13	bit 12	bit 11	bit 10	bit 9	bit 8	bit 7	bit 6	bit 5	bit 4	bit 3	bit 2	bit 1	bit 0	Initial value
00003A <sub>H</sub> 00003B <sub>H</sub> 00003E <sub>H</sub> 00003F <sub>H</sub>																	XXXXXXXX <sub>B</sub> XXXXXXXX <sub>B</sub> XXXXXXXX <sub>B</sub> XXXXXXXX <sub>B</sub>
	W	W	W	W	W	W	W	W	W	W	W	W	W	W	W	W	

R/W : Readable and writable  
 R : Read only  
 W : Write only  
 — : Unused  
 X : Indeterminate

# MB90670/675 Series

## (2) Block Diagram

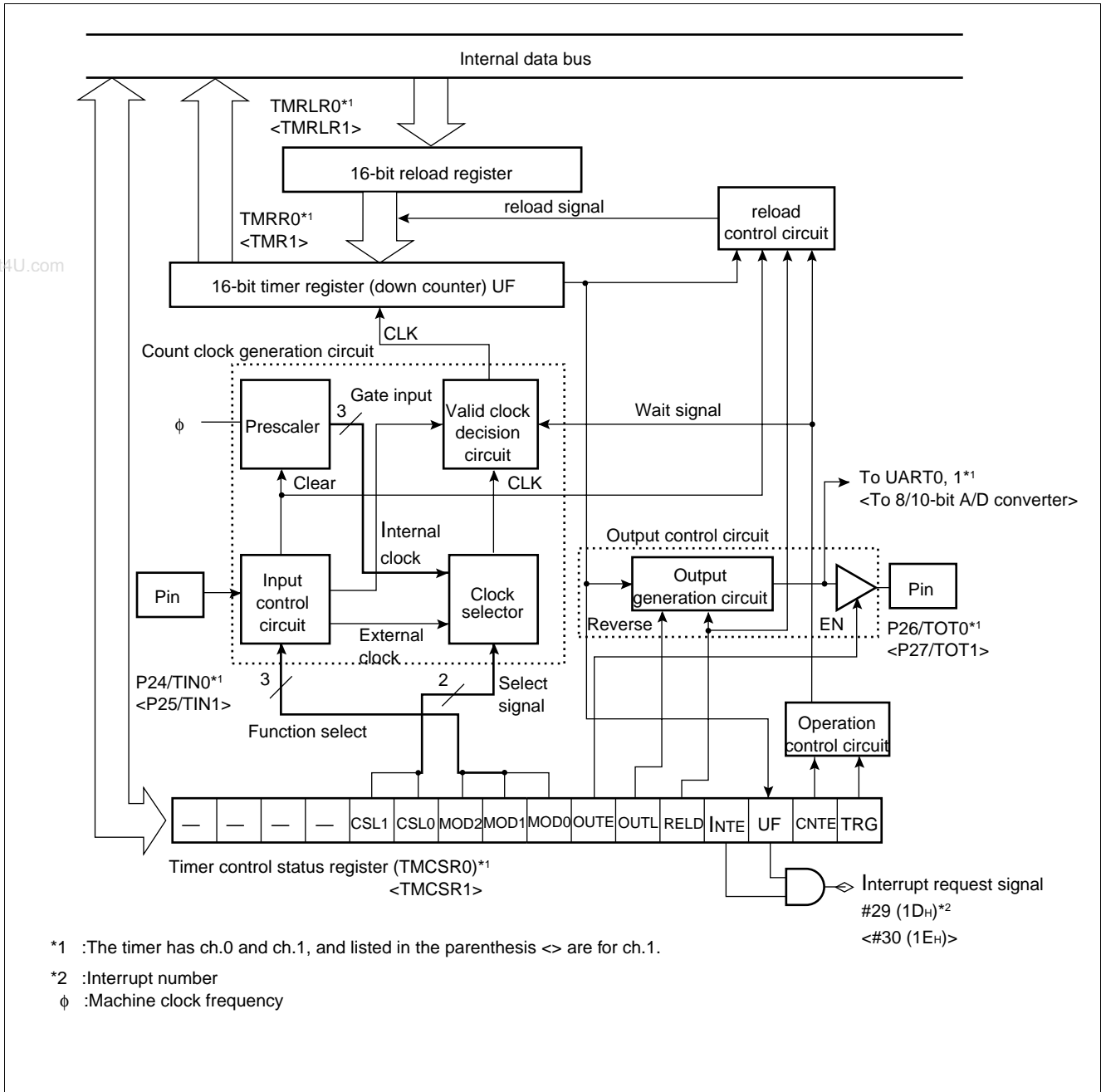

## 6. 24-bit Free run Timer

The 24-bit free-run timer is a 24-bit up counter for counting up in synchronization to divided-by-3 or divided-by-4 of the machine clock, in which an interrupt factor can be selected from the overflow interrupt and four types of timer intermediate bit interrupt to be operated as an interval timer.

The free-run timer can be used to generating reference timing signals for the input capture (ICU) and output compare (OCU).

### (1) Register Configuration

- Free-run timer control register upper digits (TCCR : H)

Address	bit 15	bit 14	bit 13	bit 12	bit 11	bit 10	bit 9	bit 8	bit 7..... bit 0	Initial value
000051H	—	—	RESV	RESV	RESV	RESV	RESV	PR0	(TCCR : L)	--111111 <sub>B</sub>
	—	—	R/W	R/W	R/W	R/W	R/W	R/W		

- Free-run timer control register lower digits (TCCR : L)

Address	bit 15..... bit 8	bit 7	bit 6	bit 5	bit 4	bit 3	bit 2	bit 1	bit 0	Initial value
000050H	(TCCR : H)	STP	CLR	IVF	IVFE	TIM	TIME	TIS1	TIS0	11000000 <sub>B</sub>
		W	W	R/W	R/W	R/W	R/W	R/W	R/W	

- Free-run timer upper data register (TCRH)

Address	bit 15	bit 14	bit 13	bit 12	bit 11	bit 10	bit 9	bit 8	bit 7	bit 6	bit 5	bit 4	bit 3	bit 2	bit 1	bit 0	Initial value
000056H 000057H	—	—	—	—	—	—	—	T23	T22	T21	T20	T19	T18	T17	T16		00000000 <sub>B</sub> 00000000 <sub>B</sub>
	R	R	R	R	R	R	R	R	R	R	R	R	R	R	R	R	

- Free-run timer lower data register (TCRL)

Address	bit 15	bit 14	bit 13	bit 12	bit 11	bit 10	bit 9	bit 8	bit 7	bit 6	bit 5	bit 4	bit 3	bit 2	bit 1	bit 0	Initial value
000054H 000055H	T15	T14	T13	T12	T11	T10	T9	T8	T7	T6	T5	T4	T3	T2	T1	T0	00000000 <sub>B</sub> 00000000 <sub>B</sub>
	R	R	R	R	R	R	R	R	R	R	R	R	R	R	R	R	

R/W : Readable and writable  
 R : Read only  
 W : Write only  
 — : Unused

# MB90670/675 Series

## (2) Block Diagram

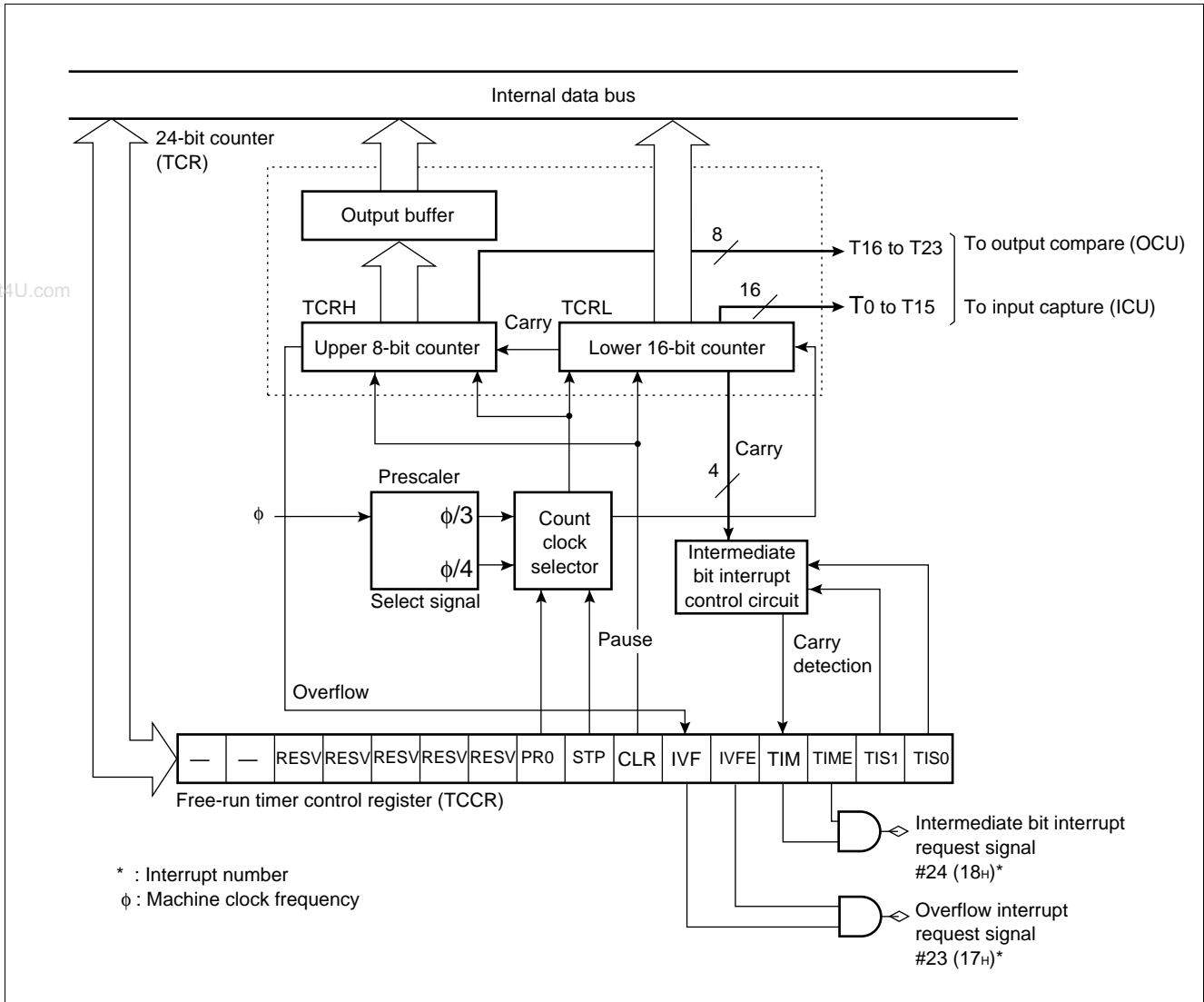

## 7. Input Capture (ICU)

The input capture (ICU) generates an interrupt request to the CPU simultaneously with a storing operation of current counter value of the 24-bit free run timer to the ICU data register (ICDR) upon an input of a trigger edge to the external pin.

There are four sets (four channels) of the input capture external pins and ICU data registers (ICDR), enabling measurements of maximum of four events.

- The input capture has four sets of external input pins (ASR0 to ASR3) and ICU registers (ICDR), enabling measurements of maximum of four events.
- A trigger edge direction can be selected from rising/falling/both edges.
- The input capture can be set to generate an interrupt request at the storage timing of the counter value of the 24-bit free run timer to the ICU data register (ICDR).
- The input compare conforms to the extended intelligent I/O service (EI<sup>2</sup>OS).
- The input capture function is suited for measurements of intervals (frequencies) and pulse-widths.

### (1) Register Configuration

- ICU control register upper digits (ICC : H)

Address	bit 15	bit 14	bit 13	bit 12	bit 11	bit 10	bit 9	bit 8	bit 7	.....	bit 0	Initial value
000053 <sub>H</sub>	IRE3	IRE2	IRE1	IRE0	IR3	IR2	IR1	IR0	(ICC : L)			00000000 <sub>B</sub>
	R/W	R/W	R/W	R/W	R/W	R/W	R/W	R/W				

- ICU control register lower digits (ICC : L)

Address	bit 15	.....	bit 8	bit 7	bit 6	bit 5	bit 4	bit 3	bit 2	bit 1	bit 0	Initial value
000052 <sub>H</sub>	(ICC : H)			EG3B	EG3A	EG2B	EG2A	EG1B	EG1A	EG0B	EG0A	00000000 <sub>B</sub>
				R/W	R/W	R/W	R/W	R/W	R/W	R/W	R/W	

- ICU upper data register 0 to 3 (ICDR0H to ICDR3H)

Address	bit 15	bit 14	bit 13	bit 12	bit 11	bit 10	bit 9	bit 8	Initial value
ICDR0H : 000063 <sub>H</sub> ICDR1H : 000067 <sub>H</sub> ICDR2H : 00006B <sub>H</sub> ICDR3H : 00006F <sub>H</sub>	—	—	—	—	—	—	—	—	00000000 <sub>B</sub>
	R	R	R	R	R	R	R	R	

Address	bit 7	bit 6	bit 5	bit 4	bit 3	bit 2	bit 1	bit 0	Initial value
ICDR0H : 000062 <sub>H</sub> ICDR1H : 000066 <sub>H</sub> ICDR2H : 00006A <sub>H</sub> ICDR3H : 00006E <sub>H</sub>	D23	D22	D21	D20	D19	D18	D17	D16	XXXXXXXX <sub>B</sub>
	R	R	R	R	R	R	R	R	

- ICU lower data register 0 to 3 (ICDR0L to ICDR3L)

Address	bit 15	bit 14	bit 13	bit 12	bit 11	bit 10	bit 9	bit 8	Initial value
ICDR0L : 000061 <sub>H</sub> ICDR1L : 000065 <sub>H</sub> ICDR2L : 000069 <sub>H</sub> ICDR3L : 00006D <sub>H</sub>	D15	D14	D13	D12	D11	D10	D9	D8	XXXXXXXX <sub>B</sub>
	R	R	R	R	R	R	R	R	

Address	bit 7	bit 6	bit 5	bit 4	bit 3	bit 2	bit 1	bit 0	Initial value
ICDR0L : 000060 <sub>H</sub> ICDR1L : 000064 <sub>H</sub> ICDR2L : 000068 <sub>H</sub> ICDR3L : 00006C <sub>H</sub>	D7	D6	D5	D4	D3	D2	D1	D0	XXXXXXXX <sub>B</sub>
	R	R	R	R	R	R	R	R	

R/W : Readable and writable  
R : Read only  
— : Unused  
X : Indeterminate

# MB90670/675 Series

## (2) Block Diagram

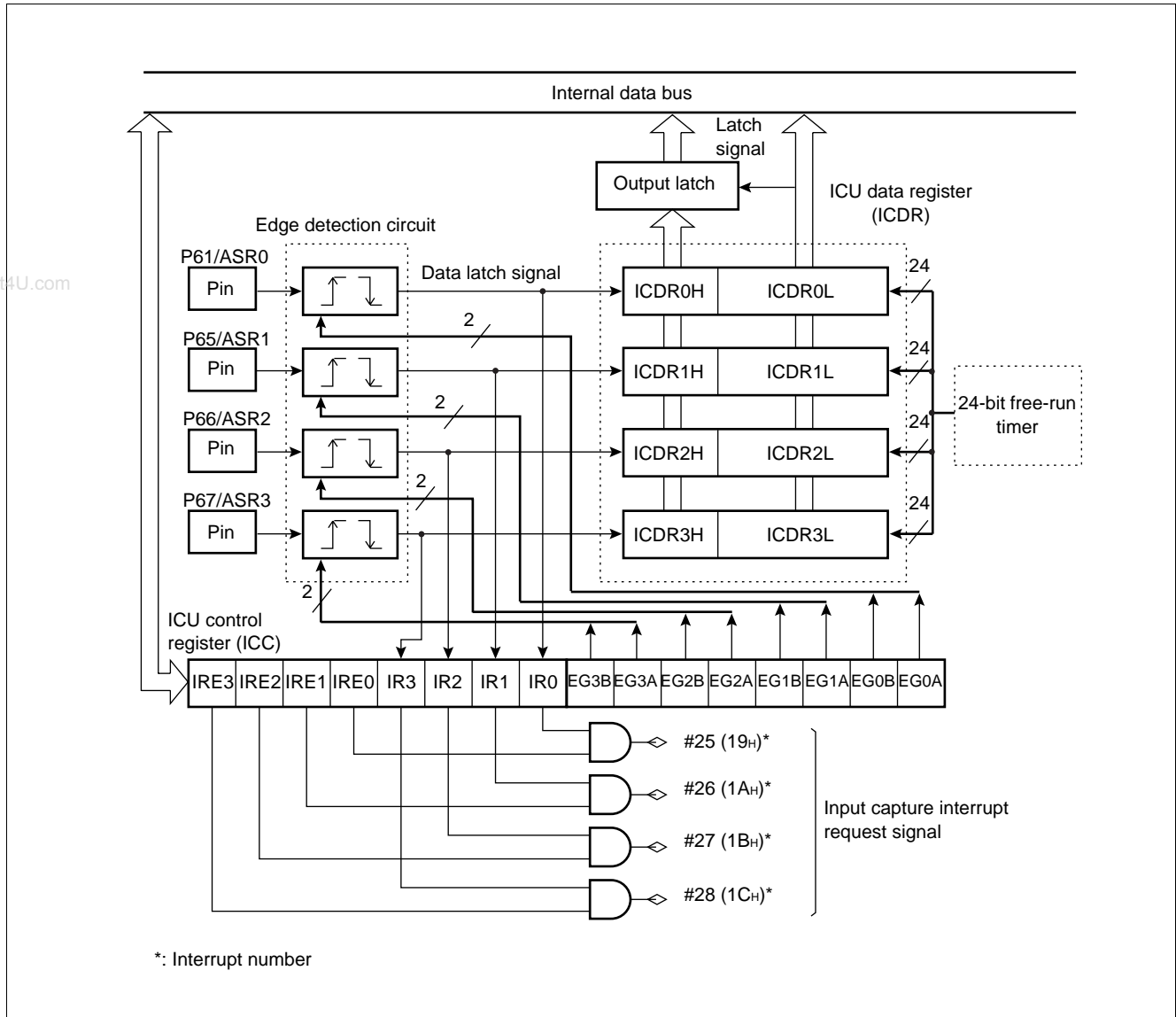

## 8. Output Compare (OCU)

The output compare (OCU) is two sets of compare units consisting of four-channel OCU compare data registers, a comparator and a control register.

An interrupt request can be generated for each channel upon a match detection by performing time-division comparison between the OCU compare data register setting value and the counter value of the 24-bit free-run timer.

The DOT pin can be used as a waveform output pin for reversing output upon a match detection or a general-purpose output port for directly outputting the setting value of the DOT bit.

### (1) Register Configuration

• OCU control register 00 upper digits (CCR00 : H)											
Address	bit 15	bit 14	bit 13	bit 12	bit 11	bit 10	bit 9	bit 8	bit 7.....	bit 0	Initial value
000059 <sub>H</sub>	—	—	—	—	MD3	MD2	MD1	MD0	(CCR00 : L)		---- 0000 <sub>B</sub>
					R/W	R/W	R/W	R/W			
• OCU control register 00 lower digits (CCR00 : L)											
Address	bit 15.....	bit 8	bit 7	bit 6	bit 5	bit 4	bit 3	bit 2	bit 1	bit 0	Initial value
000058 <sub>H</sub>	(CCR00 : H)		RESV	RESV	RESV	RESV	CPE3	CPE2	CPE1	CPE0	11110000 <sub>B</sub>
			R/W	R/W	R/W	R/W	R/W	R/W	R/W	R/W	
• OCU control register 01 upper digits (CCR01 : H)											
Address	bit 15	bit 14	bit 13	bit 12	bit 11	bit 10	bit 9	bit 8	bit 7.....	bit 0	Initial value
00005B <sub>H</sub>	ICE3	ICE2	ICE1	ICE0	IC3	IC2	IC1	IC0	(CCR01 : L)		00000000 <sub>B</sub>
	R/W	R/W	R/W	R/W	R/W	R/W	R/W	R/W			
• OCU control register 01 lower digits (CCR01 : L)											
Address	bit 15.....	bit 8	bit 7	bit 6	bit 5	bit 4	bit 3	bit 2	bit 1	bit 0	Initial value
00005A <sub>H</sub>	(CCR01 : H)		—	—	—	—	DOT3	DOT2	DOT1	DOT0	---- 0000 <sub>B</sub>
			—	—	—	—	R/W	R/W	R/W	R/W	
R/W : Readable and writable — : Unused											

(Continued)

# MB90670/675 Series

(Continued)

- OCU compare upper data register 0 to 7 (CPR00H to CPR07H)

Address	bit 15	bit 14	bit 13	bit 12	bit 11	bit 10	bit 9	bit 8	Initial value
CPR00H : 000073H	—	—	—	—	—	—	—	—	00000000 <sub>B</sub>
CPR01H : 000077H									
CPR02H : 00007BH									
CPR03H : 00007FH									
CPR04H : 000083H									
CPR05H : 000087H									
CPR06H : 00008BH									
CPR07H : 00008FH									

Address	bit 7	bit 6	bit 5	bit 4	bit 3	bit 2	bit 1	bit 0	Initial value
CPR00H : 000072H	D23	D22	D21	D20	D19	D18	D17	D16	00000000 <sub>B</sub>
CPR01H : 000076H									
CPR02H : 00007AH									
CPR03H : 00007EH									
CPR04H : 000082H									
CPR05H : 000086H									
CPR06H : 00008AH									
CPR07H : 00008EH									

- OCU compare lower data register 0 to 7 (CPR00L to CPR07L)

Address	bit 15	bit 14	bit 13	bit 12	bit 11	bit 10	bit 9	bit 8	Initial value
CPR00L : 000071H	D15	D14	D13	D12	D11	D10	D9	D8	00000000 <sub>B</sub>
CPR01L : 000075H									
CPR02L : 000079H									
CPR03L : 00007DH									
CPR04L : 000081H									
CPR05L : 000085H									
CPR06L : 000089H									
CPR07L : 00008DH									

Address	bit 7	bit 6	bit 5	bit 4	bit 3	bit 2	bit 1	bit 0	Initial value
CPR00L : 000070H	D7	D6	D5	D4	D3	D2	D1	D0	00000000 <sub>B</sub>
CPR01L : 000074H									
CPR02L : 000078H									
CPR03L : 00007CH									
CPR04L : 000080H									
CPR05L : 000084H									
CPR06L : 000088H									
CPR07L : 00008CH									

R/W : Readable and writable  
 — : Unused



## (2) Block Diagram of Output Compare (OCU)

- Overall block diagram

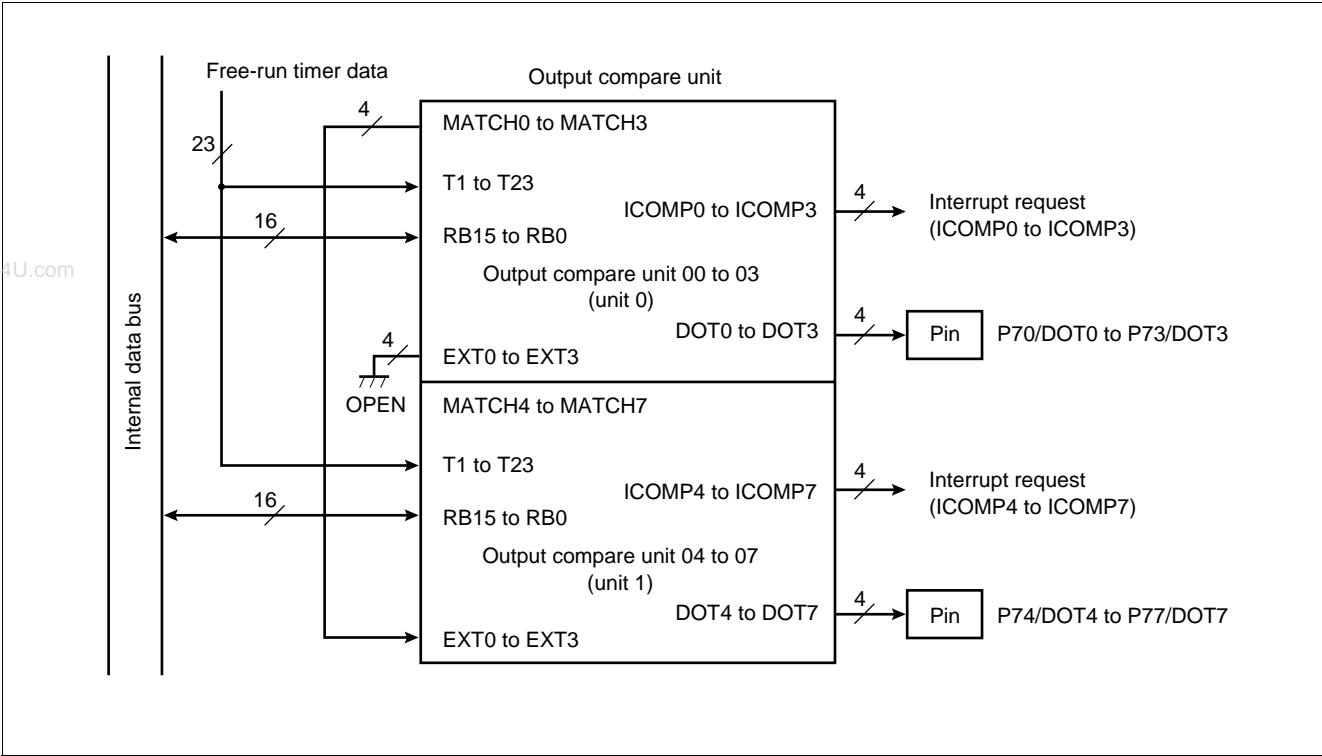

# MB90670/675 Series

## • Block diagram of unit 0

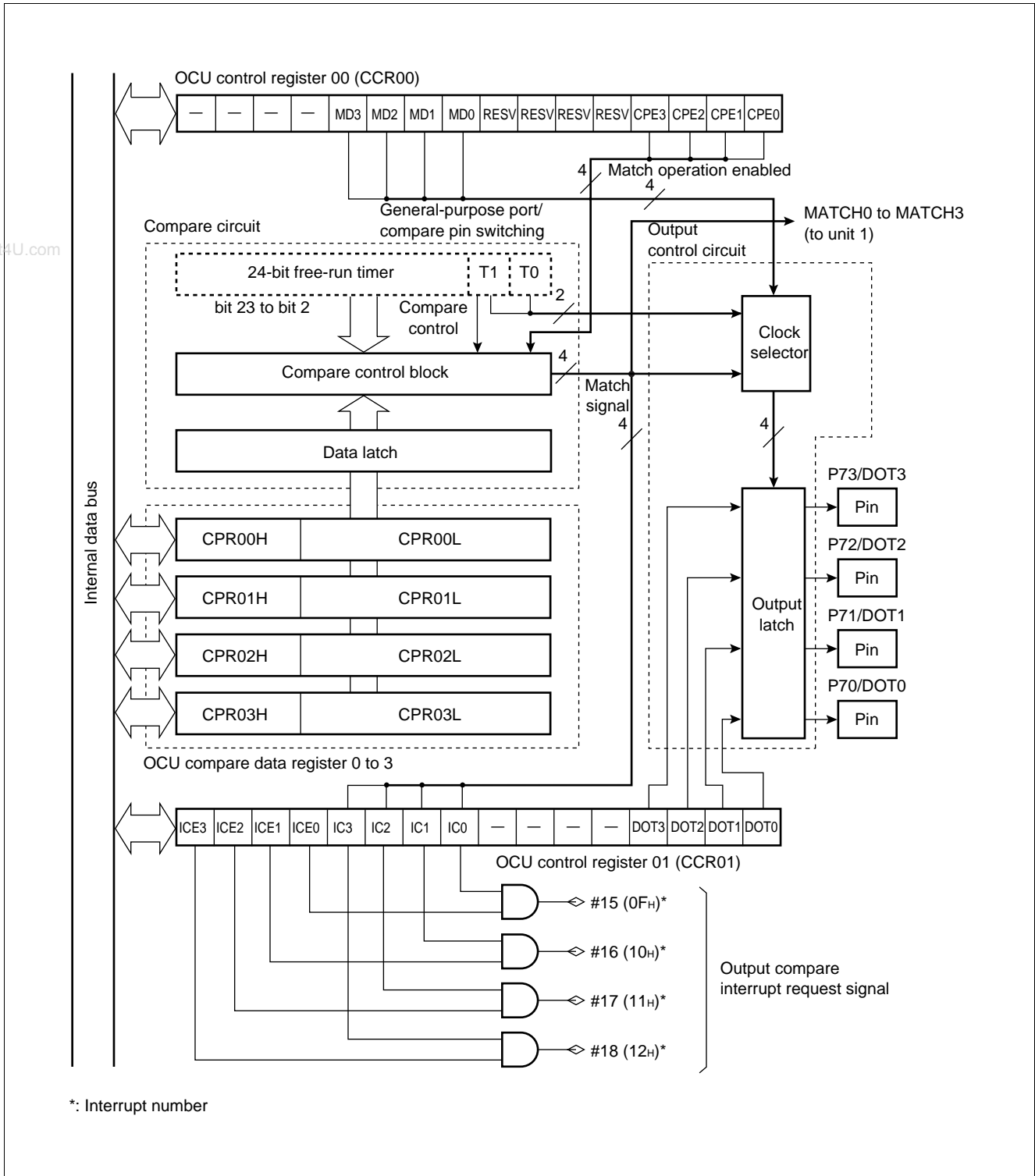

\*: Interrupt number

• Block diagram of unit 1

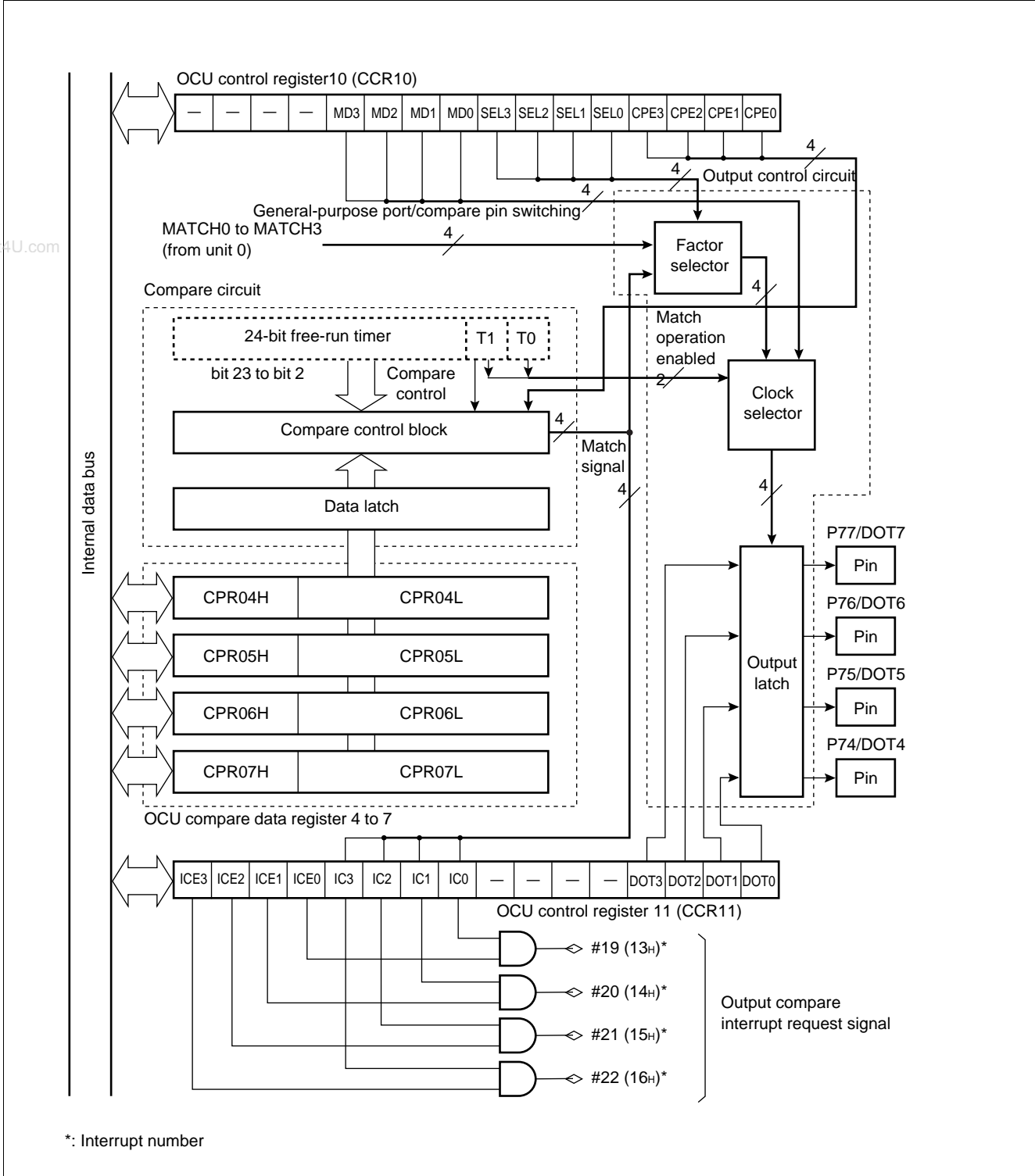

# MB90670/675 Series

## 9. I<sup>2</sup>C Interface (Included Only in MB90675 Series)

The I<sup>2</sup>C interface is a serial I/O port supporting Inter IC BUS operating as master/slave devices on I<sup>2</sup>C bus and has the following features.

- Master/slave transmission/reception
- Arbitration function
- Clock synchronization function
- Slave address/general call address detection function
- Transmission direction detection function
- Repeated generation function start condition and detection function
- Bus error detection function

### (1) Register Configuration

- I<sup>2</sup>C bus status register (IBSR)

Address	bit 15	bit 14	bit 13	bit 12	bit 11	bit 10	bit 9	bit 8	bit 7	bit 6	bit 5	bit 4	bit 3	bit 2	bit 1	bit 0	Initial value
000040H	(IBCR)								BB	RSC	AL	LRB	TRX	AAS	GCA	FBT	00000000 <sub>B</sub>
									R	R	R	R	R	R	R	R	

- I<sup>2</sup>C bus control register (IBCR)

Address	bit 15	bit 14	bit 13	bit 12	bit 11	bit 10	bit 9	bit 8	bit 7	bit 6	bit 5	bit 4	bit 3	bit 2	bit 1	bit 0	Initial value
000041H	BER	BEIE	SCC	MSS	ACK	GCAA	INTE	INT	(IBSR)								00000000 <sub>B</sub>
	R/W	R/W	R/W	R/W	R/W	R/W	R/W	R/W									

- I<sup>2</sup>C bus clock control register (ICCR)

Address	bit 15	bit 14	bit 13	bit 12	bit 11	bit 10	bit 9	bit 8	bit 7	bit 6	bit 5	bit 4	bit 3	bit 2	bit 1	bit 0	Initial value
000042H	(IADR)								—	—	EN	CS4	CS3	CS2	CS1	CS0	--0XXXXX <sub>B</sub>
											R/W	R/W	R/W	R/W	R/W	R/W	

- I<sup>2</sup>C address register (IADR)

Address	bit 15	bit 14	bit 13	bit 12	bit 11	bit 10	bit 9	bit 8	bit 7	bit 6	bit 5	bit 4	bit 3	bit 2	bit 1	bit 0	Initial value
000043H (IADR)	—	A6	A5	A4	A3	A2	A1	A0	(ICCR)								-XXXXXXXX <sub>B</sub>
		R/W	R/W	R/W	R/W	R/W	R/W	R/W									

Address	bit 15	bit 14	bit 13	bit 12	bit 11	bit 10	bit 9	bit 8	bit 7	bit 6	bit 5	bit 4	bit 3	bit 2	bit 1	bit 0	Initial value
000044H (IDAR)	(Reserved area)								D7	D6	D5	D4	D3	D2	D1	D0	XXXXXXXX <sub>B</sub>
									R/W	R/W	R/W	R/W	R/W	R/W	R/W	R/W	

R/W: Readable and writable  
 R : Read only  
 — : Unused  
 X : Indeterminate

**(2) Block Diagram**

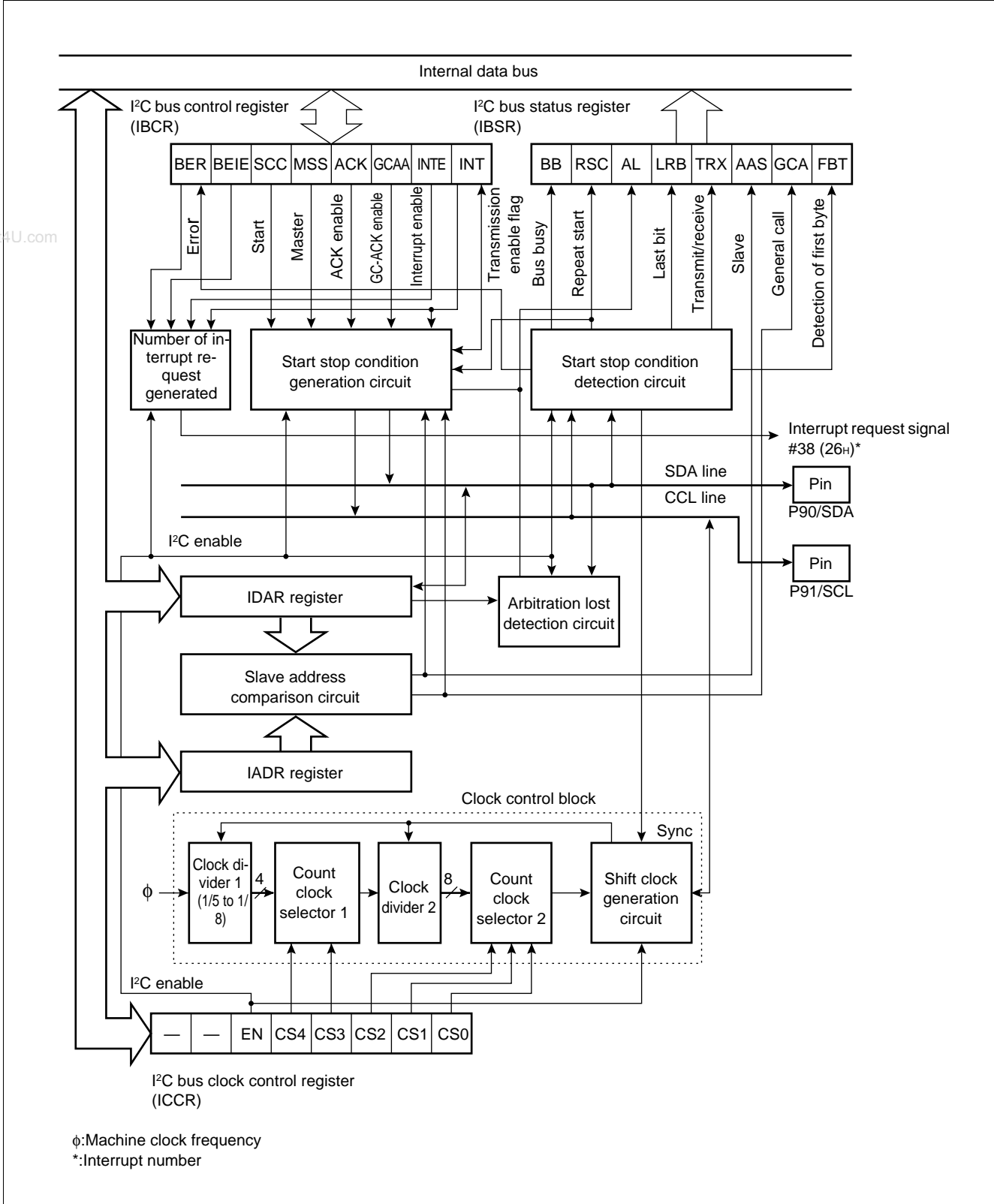

# MB90670/675 Series

## 10. UART0

UART0 is a general-purpose serial data communication interface for performing synchronous or asynchronous communication (start-stop synchronization system). In addition to the normal duplex communication function (normal mode), UART0 has a master/slave type communication function (multi-processor mode).

- Data buffer: Full-duplex double buffer
- Transfer mode: Clock synchronized (with start and stop bit)  
Clock asynchronous (start-stop synchronization system)
- Baud rate: With dedicated baud rate generator, selectable from 12 types  
External clock input possible  
Internal clock (a clock supplied from 16-bit reload timer can be used.)
- Data length: 7 bits to 9 bits selective (with a parity bit)  
6 bits to 8 bits selective (without a parity bit)
- Signal format: NRZ (Non Return to Zero) system
- Reception error detection: Framing error  
Overrun error  
Parity error (not available in multi-processor mode)
- Interrupt request: Receive interrupt (reception complete, receive error detection)  
Receive interrupt (transmission complete)  
Transmit/receive conforms to extended intelligent I/O service (EI<sup>2</sup>OS)
- Master/slave type communication function (multi-processor mode): 1 (master) to n (slave) communication possible

### (1) Register Configuration

• Status register 0 (USR0)												
Address	bit 15	bit 14	bit 13	bit 12	bit 11	bit 10	bit 9	bit 8	bit 7	..... bit 0	Initial value	
000021 <sub>H</sub>	RDRF	ORFE	PE	TDRE	RIE	TIE	RBF	TBF	(UMC0)		00100000 <sub>B</sub>	
	R/W	R/W	R/W	R/W	R/W	R/W	R/W	R/W				
• Mode control register 0 (UMC0)												
Address	bit 15	..... bit 8	bit 7	bit 6	bit 5	bit 4	bit 3	bit 2	bit 1	bit 0	Initial value	
000020 <sub>H</sub>	(USR0)		PEN	SBL	MC1	MC0	SMDE	RFC	SCKE	SOE	00000100 <sub>B</sub>	
			R/W	R/W	R/W	R/W	R/W	R/W	R/W	R/W		
• Rate and data register 0 (URD0)												
Address	bit 15	bit 14	bit 13	bit 12	bit 11	bit 10	bit 9	bit 8	bit 7	..... bit 0	Initial value	
000023 <sub>H</sub>	BCH	RC3	RC2	RC1	RC0	BCH0	P	D8	(UIDR0/UODR0)		00000000 <sub>B</sub>	
	R/W	R/W	R/W	R/W	R/W	R/W	R/W	R/W				
• Input data register 0 (UIDR0)												
Address	bit 15	..... bit 9	bit 8	bit 7	bit 6	bit 5	bit 4	bit 3	bit 2	bit 1	bit 0	Initial value
000022 <sub>H</sub>	(URD0)		D8	D7	D6	D5	D4	D3	D2	D1	D0	XXXXXXXX <sub>B</sub>
			R	R	R	R	R	R	R	R	R	
• Output data register 0 (UODR)												
Address	bit 15	..... bit 9	bit 8	bit 7	bit 6	bit 5	bit 4	bit 3	bit 2	bit 1	bit 0	Initial value
000022 <sub>H</sub>	(URD0)		D8	D7	D6	D5	D4	D3	D2	D1	D0	XXXXXXXX <sub>B</sub>
			W	W	W	W	W	W	W	W	W	
R/W : Readable and writable R : Read only W : Write only X : Indeterminate												

## (2) Block Diagram

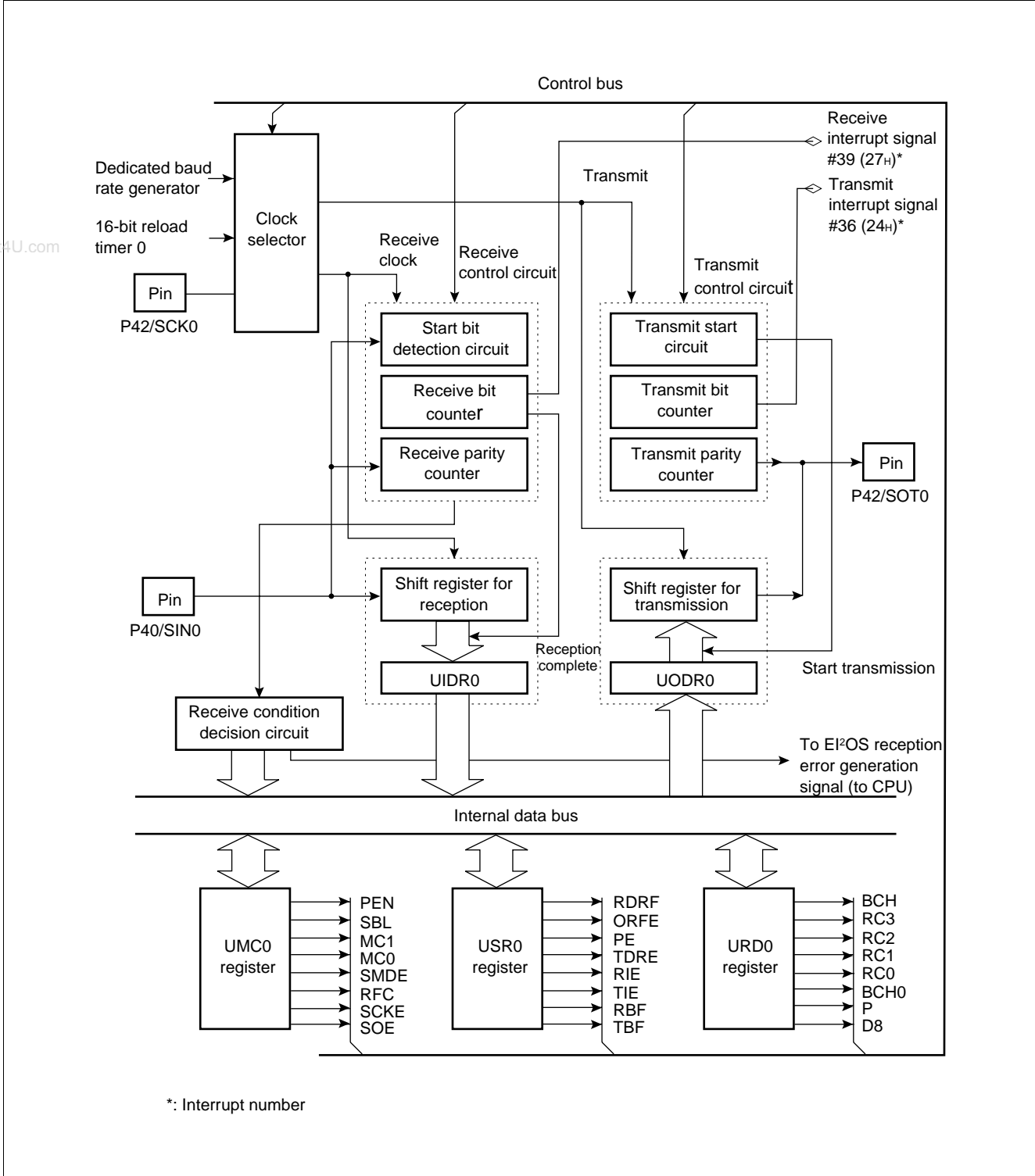

# MB90670/675 Series

## 11. UART1 (SCI)

UART1 (SCI) is a general-purpose serial data communication interface for performing synchronous or asynchronous communication (start-stop synchronization system). In addition to the normal duplex communication function (normal mode), UART1 has a master-slave type communication function (multi-processor mode).

- Data buffer: Full-duplex double buffer
- Transfer mode: Clock synchronized (no start or stop bit)  
Clock asynchronous (start-stop synchronization system)
- Baud rate: With dedicated baud rate generator, selectable from 8 types  
External clock input possible  
Internal clock (a internal clock supplied from 16-bit reload timer can be used.)
- Data length: 7 bits (for asynchronous normal mode only)  
8 bits
- Signal format: NRZ (Non Return to Zero) system
- Reception error detection: Framing error  
Overrun error  
Parity error (not available in multi-processor mode)
- Interrupt request: Receive interrupt (reception complete, receive error detection)  
Receive interrupt (transmission complete)  
Transmit/receive conforms to extended intelligent I/O service (EI<sup>2</sup>OS)
- Master/slave type communication function (multi-processor mode): 1 (master) to n (slave) communication possible (supported only for master station)

### (1) Register Configuration

#### • Control register 1 (SCR1)

Address	bit 15	bit 14	bit 13	bit 12	bit 11	bit 10	bit 9	bit 8	bit 7	.....	bit 0	Initial value
000025H	PEN	P	SBL	CL	A/D	REC	RXE	TXE	(SMR1)			00000100 <sub>B</sub>
	R/W	R/W	R/W	R/W	R/W	R/W	R/W	R/W	R/W			

#### • Mode register 1 (SMR1)

Address	bit 15	.....	bit 8	bit 7	bit 6	bit 5	bit 4	bit 3	bit 2	bit 1	bit 0	Initial value
000024H	(SCR1)			MD1	MD0	CS2	CS1	CS0	BCH	SCKE	SOE	00000000 <sub>B</sub>
			R/W	R/W	R/W	R/W	R/W	R/W	R/W	R/W	R/W	

#### • Status register 1 (SSR1)

Address	bit 15	bit 14	bit 13	bit 12	bit 11	bit 10	bit 9	bit 8	bit 7	.....	bit 0	Initial value
000027H	PE	ORE	FRE	RDRF	TDRE	—	RIE	TIE	(SIDR1/SODR1)			00001-00 <sub>B</sub>
	R	R	R	R	R	—	R/W	R/W				

#### • Input data register 1 (SIDR1)

Address	bit 15	.....	bit 8	bit 7	bit 6	bit 5	bit 4	bit 3	bit 2	bit 1	bit 0	Initial value
000026H	(SSR1)			D7	D6	D5	D4	D3	D2	D1	D0	XXXXXXXX <sub>B</sub>
			R	R	R	R	R	R	R	R	R	

#### • Output data register 1 (SODR1)

Address	bit 15	.....	bit 8	bit 7	bit 6	bit 5	bit 4	bit 3	bit 2	bit 1	bit 0	Initial value
000026H	(SSR1)			D7	D6	D5	D4	D3	D2	D1	D0	XXXXXXXX <sub>B</sub>
			W	W	W	W	W	W	W	W	W	

R/W : Readable and writable  
 R : Read only  
 W : Write only  
 — : Unused  
 X : Indeterminate



## (2) Block Diagram

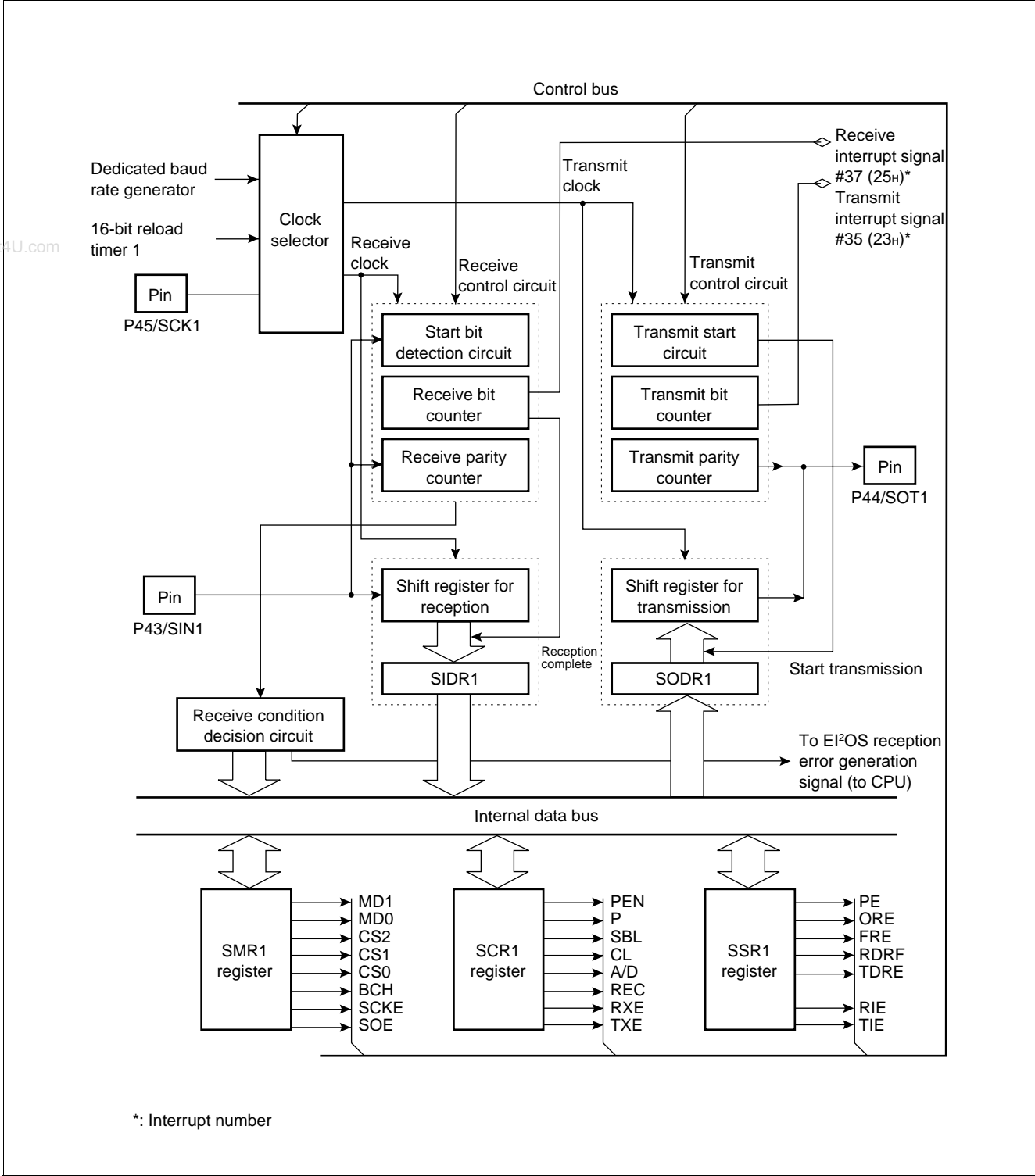

## 12. DTP/External Interrupt Circuit

The DTP (Data Transfer Peripheral)/external interrupt circuit is located between peripheral equipment connected externally and the F<sup>2</sup>MC-16L CPU and transmits interrupt requests or data transfer requests generated by peripheral equipment to the CPU, generates external interrupt request and starts the extended intelligent I/O service (EI<sup>2</sup>OS).

### (1) Register Configuration

• DTP/interrupt factor register (EIRR)												
Address	bit 15	bit 14	bit 13	bit 12	bit 11	bit 10	bit 9	bit 8	bit 7	.....	bit 0	Initial value
000029 <sub>H</sub>	—	—	—	—	ER3	ER2	ER1	ER0	(ENIR)			----0000 <sub>B</sub>
	—	—	—	—	R/W	R/W	R/W	R/W				
• DTP/interrupt enable register (ENIR)												
Address	bit 15	.....	bit 8	bit 7	bit 6	bit 5	bit 4	bit 3	bit 2	bit 1	bit 0	Initial value
000028 <sub>H</sub>	(EIRR)			—	—	—	—	EN3	EN2	EN1	EN0	----0000 <sub>B</sub>
				—	—	—	—	R/W	R/W	R/W	R/W	
• Request level setting register (ELVR)												
Address	bit 15	.....	bit 8	bit 7	bit 6	bit 5	bit 4	bit 3	bit 2	bit 1	bit 0	Initial value
00002A <sub>H</sub>	(Vacancy)			LB3	LA3	LB2	LA2	LB1	LA1	LB0	LA0	00000000 <sub>B</sub>
				R/W	R/W	R/W	R/W	R/W	R/W	R/W	R/W	
R/W : Readable and writable												
— : Unused												

## (2) Block Diagram

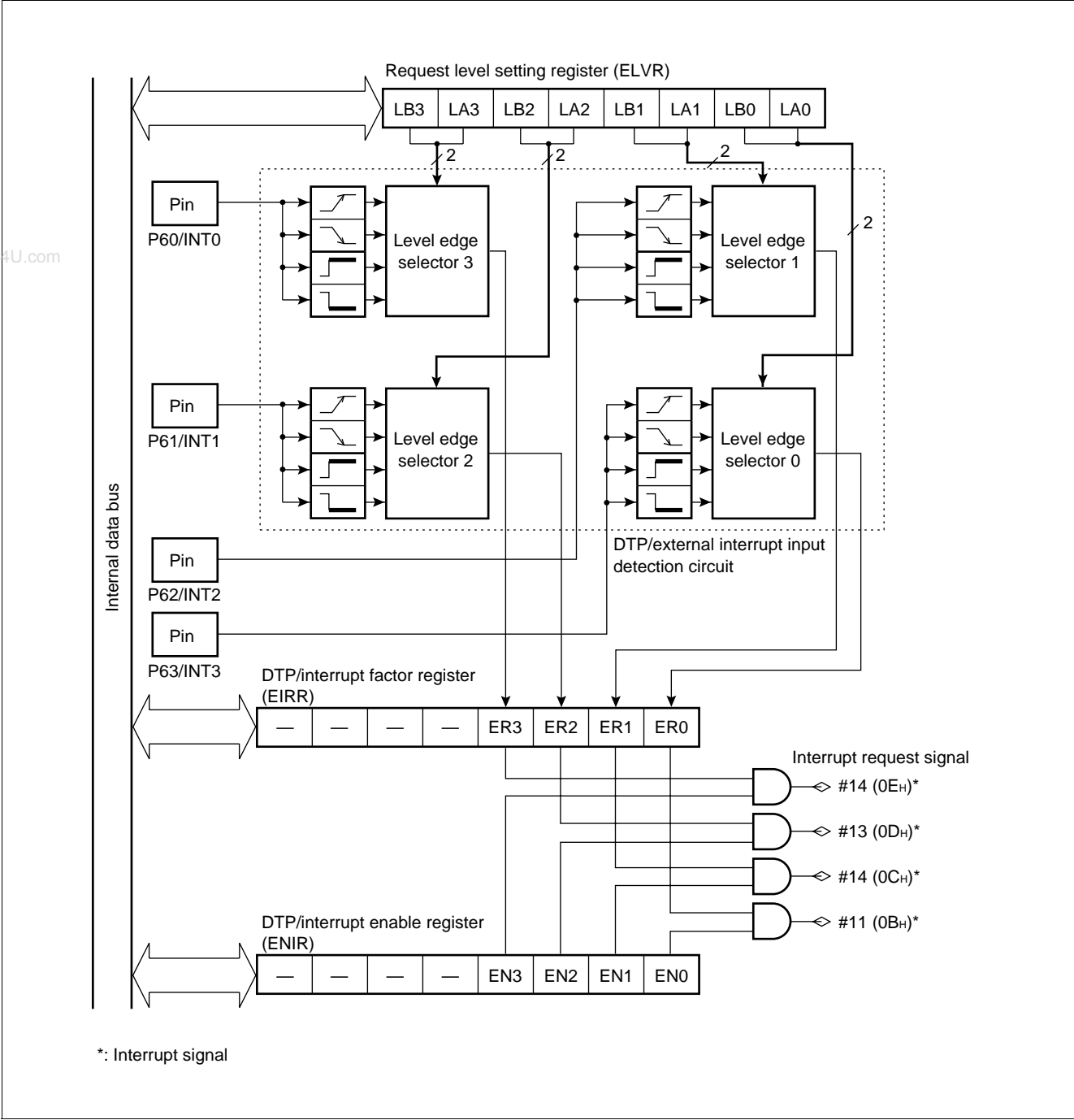

# MB90670/675 Series

## 13. Wake-up Interrupt

Wake-up interrupts transmits interrupt request ("L" level) generated by peripheral device located between external peripheral devices and the F<sup>2</sup>MC-16L CPU to the CPU and invokes interrupt processing.

The interrupt does not conform to the extended intelligent I/O service (EI<sup>2</sup>OS).

### (1) Register Configuration

- Wake-up interrupt flag register (EIFR)

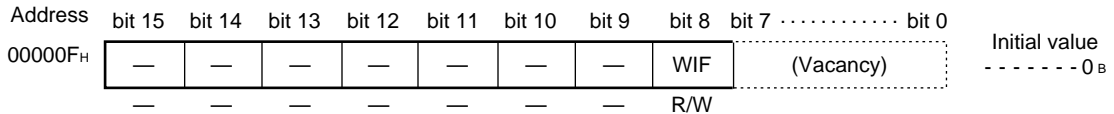

- Wake-up interrupt enable register (EICR)

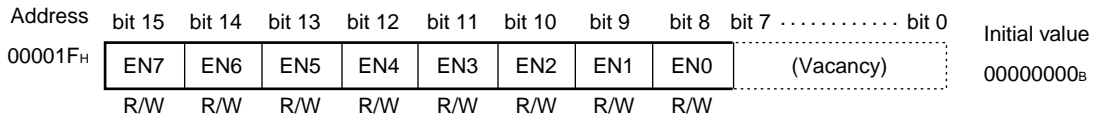

R/W : Readable and writable  
 — : Unused

### (2) Block Diagram

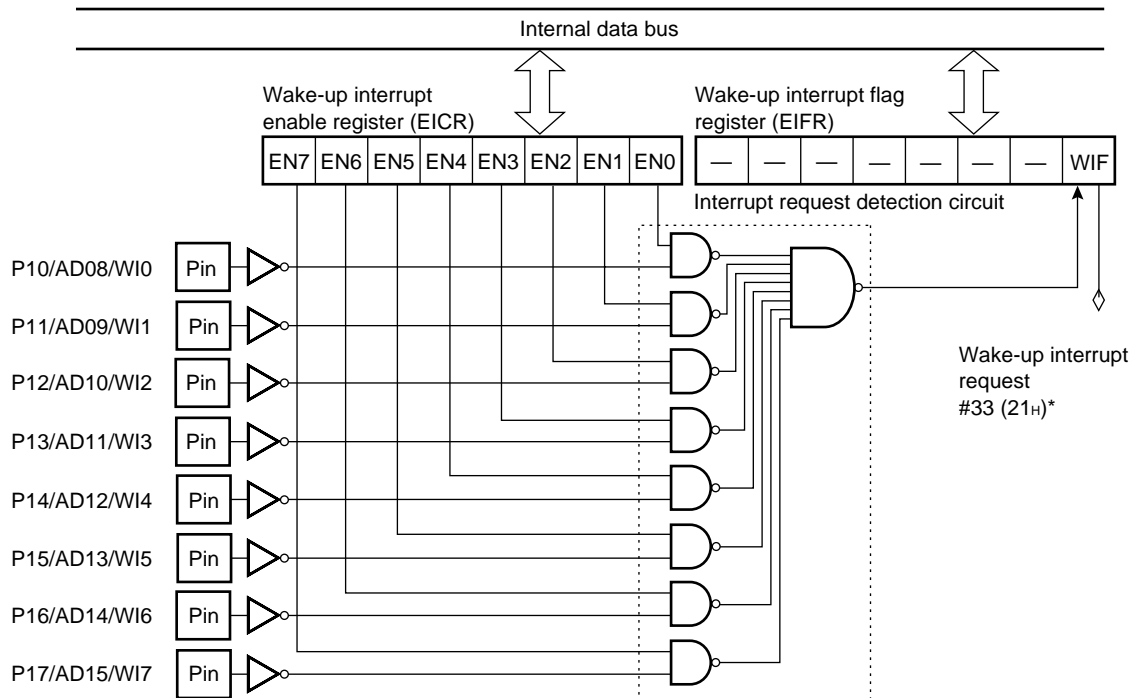

\*: Interrupt number



# MB90670/675 Series

## 15. 8/10-bit A/D Converter

The 8/10-bit A/D converter has a function of converting analog voltage input to the analog input pins (input voltage) to digital values (A/D conversion) and has the following features.

- Minimum conversion time: 6.13  $\mu$ s (at machine clock of 16 MHz, including sampling time)
- Minimum sampling time: 3.75  $\mu$ s (at machine clock of 16 MHz)
- Conversion method: RC successive approximation method with a sample and hold circuit.
- Resolution: 10-bit or 8-bit selective
- Analog input pins: Selectable from eight channels by software

One-shot conversion mode: Stops conversion after completing a conversion for a stopped channel (one channel only) or for successive channels (maximum of eight channels can be specified)

Continuous conversion mode: Continues conversions for a specified channel (one channel only) or for successive channels (maximum of eight channels can be specified)

Stop conversion mode: Stops conversion after completing a conversion for one channel and wait for the next activation.

- Interrupt requests can be generated and the extended intelligent I/O service (EI<sup>2</sup>OS) can be started after the end of A/D conversion.
- When interrupts are enabled, there is no loss of data even in continuous operations because the conversion data protection function is in effect.
- Starting factors for conversion: Selected from software activation, 16-bit reload timer 1 output (rising edge), and external trigger (falling edge).

### (1) Register Configuration

- A/D control status register upper digits (ADCS: H)

Address	bit 15	bit 14	bit 13	bit 12	bit 11	bit 10	bit 9	bit 8	bit 7	.....	bit 0	Initial value
00002D <sub>H</sub>	BUSY	INT	INTE	PAUS	STS1	STS0	STRT	RESV	(ADCS: L)			00000000 <sub>B</sub>
	R/W	R/W	R/W	R/W	R/W	R/W	W	R/W				

- A/D control status register lower digits (ADCS: L)

Address	bit 15	.....	bit 8	bit 7	bit 6	bit 5	bit 4	bit 3	bit 2	bit 1	bit 0	Initial value
00002C <sub>H</sub>	(ADCS: H)			MD1	MD0	ANS2	ANS1	ANS0	ANE2	ANE1	ANE0	00000000 <sub>B</sub>
				R/W	R/W	R/W	R/W	R/W	R/W	R/W	R/W	

- A/D data register (ADCR)

Address	bit 15	bit 14	bit 13	bit 12	bit 11	bit 10	bit 9	bit 8	bit 7	bit 6	bit 5	bit 4	bit 3	bit 2	bit 1	bit 0	Initial value
00002E <sub>H</sub>	S10	—	—	—	—	—	D9	D8	D7	D6	D5	D4	D3	D2	D1	D0	XXXXXXXX <sub>B</sub> 0000000X <sub>B</sub>
	R/W	—	—	—	—	—	R	R	R	R	R	R	R	R	R	R	

R/W : Readable and writable

R : Read only

W : Write only

— : Unused

X : Indeterminate

**(2) Block Diagram**

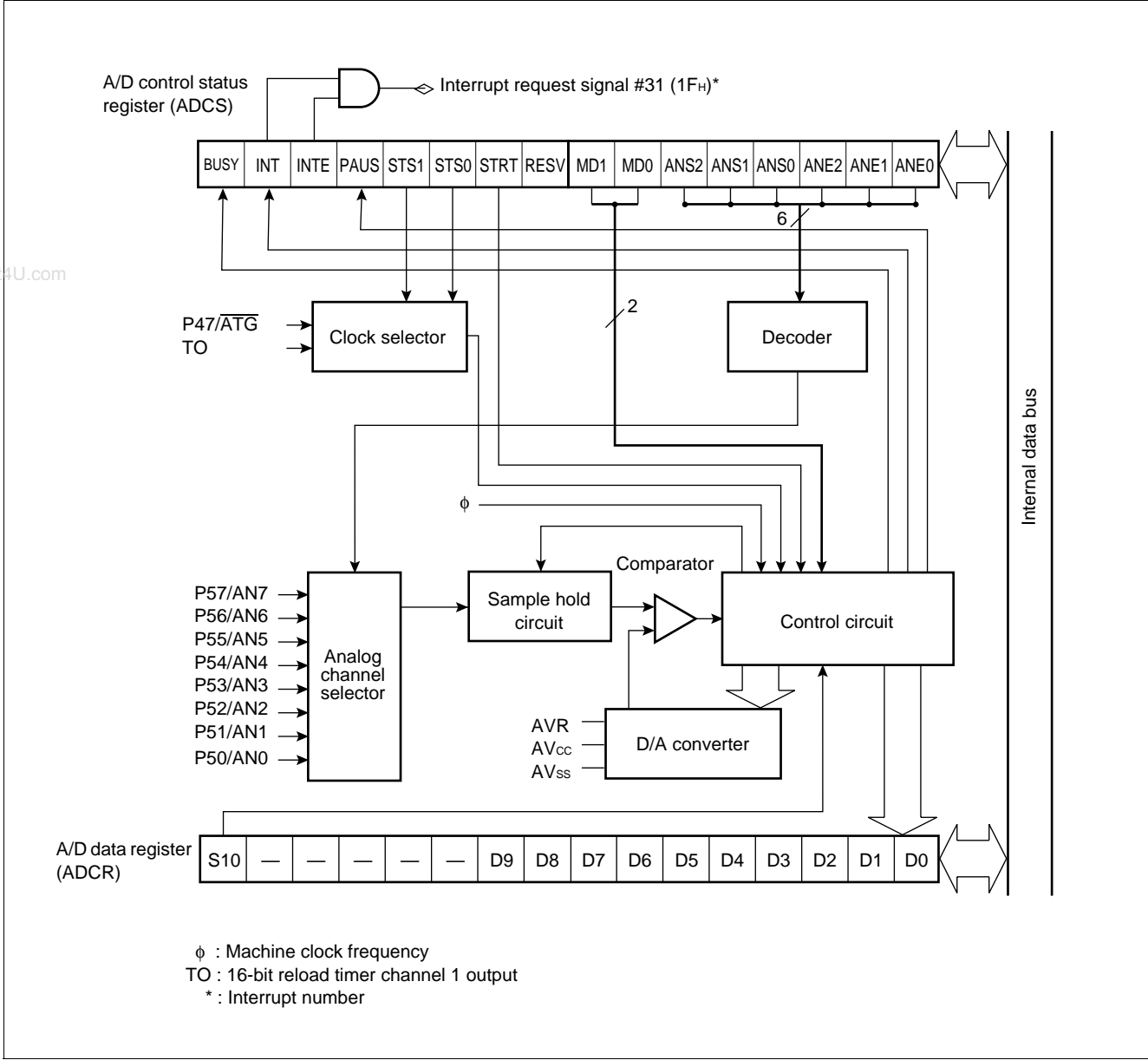

# MB90670/675 Series

## 16. Low-power Consumption (Standby) Mode

The F<sup>2</sup>MC-16L has the following CPU operating mode configured by selection of an operating clock and clock operation control.

- **Clock mode**

PLL clock mode: A mode in which the CPU and peripheral equipment are driven by PLL-multiplied oscillation clock (HCLK).

Main clock mode: A mode in which the CPU and peripheral equipment are driven by divided-by-2 of the oscillation clock (HCLK).

The PLL multiplication circuits stops in the main clock mode.

- **CPU intermittent operation mode**

The CPU intermittent operation mode is a mode for reducing power consumption by operating the CPU intermittently while external bus and peripheral functions are operated at a high-speed.

- **Hardware stand-by mode**

The hardware standby mode is a mode for reducing power consumption by stopping clock supply (sleep mode) to the CPU by the low-power consumption control circuit, stopping clock supplies to the CPU and peripheral functions (timebase timer mode), and stopping oscillation clock (stop mode, hardware standby mode).

Of these modes, modes other than the PLL clock mode are power consumption modes.

### (1) Register Configuration

- **Clock select register (CKSCR)**

Address	bit 15	bit 14	bit 13	bit 12	bit 11	bit 10	bit 9	bit 8	bit 7	.....	bit 0	Initial value
0000A1H	RESV	MCM	WS1	WS0	RESV	MCS	CS1	CS0	(LPMCR)			11111100 <sub>B</sub>
	R/W	R	R/W	R/W	R/W	R/W	W	R/W				

- **Low-power consumption mode control register (LPMCR)**

Address	bit 15	.....	bit 8	bit 7	bit 6	bit 5	bit 4	bit 3	bit 2	bit 1	bit 0	Initial value
0000A0H	(CKSCR)			STP	SLP	SPL	RST	RESV	CG1	CG0	RESV	00011000 <sub>B</sub>
				W	W	R/W	W	R/W	R/W	R/W	R/W	

R/W : Readable and writable  
 R : Read only  
 W : Write only



# MB90670/675 Series

## (2) Block Diagram

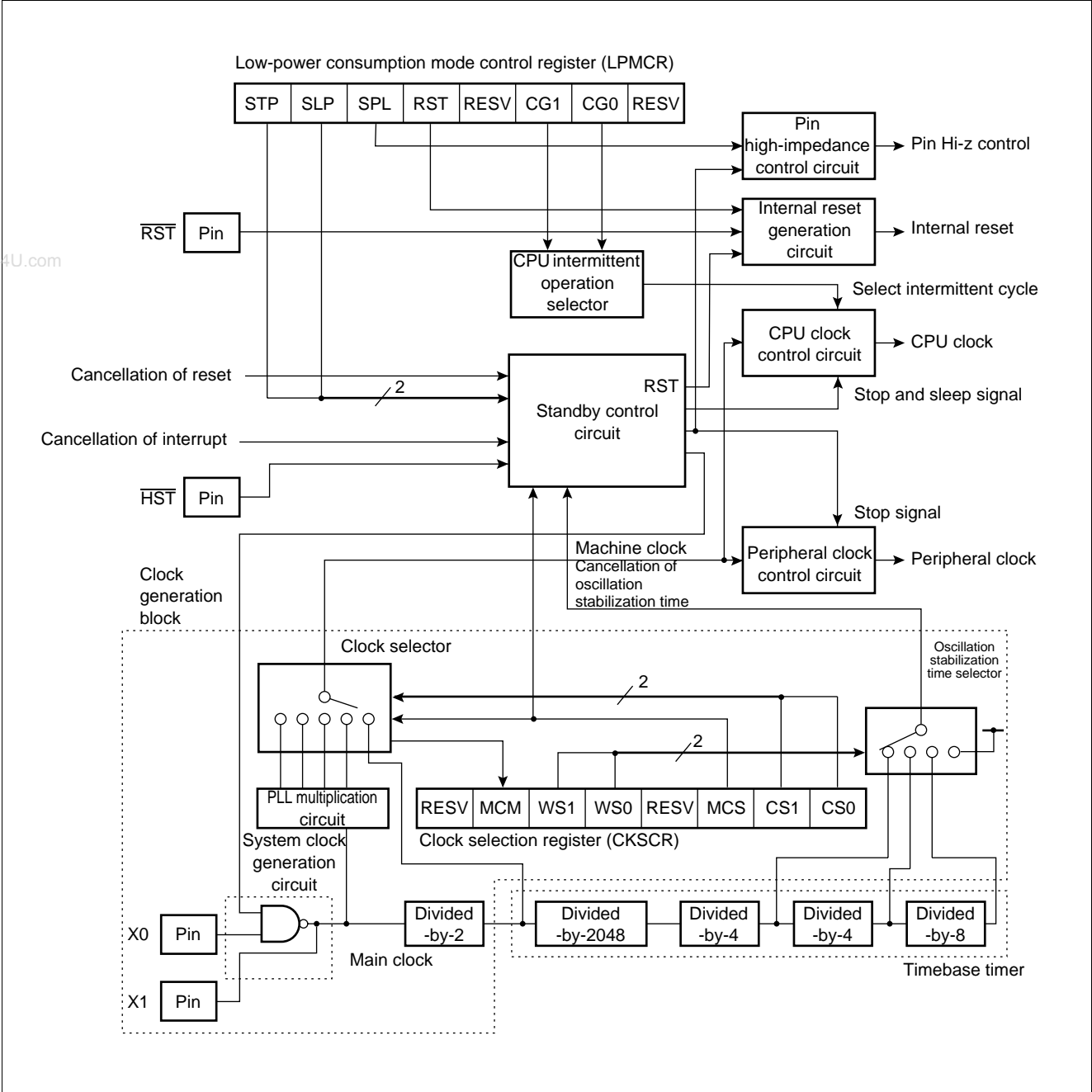

# MB90670/675 Series

## ■ ELECTRICAL CHARACTERISTICS

### 1. Absolute Maximum Ratings

( $V_{SS} = V_{SS} = 0.0\text{ V}$ )

Parameter	Symbol	Value		Unit	Remarks
		Min.	Max.		
Power supply voltage	$V_{CC}$	$V_{SS} - 0.3$	$V_{SS} + 7.0$	V	
	$AV_{CC}$	$V_{SS} - 0.3$	$V_{SS} + 7.0$	V	*1
	AVRH, AVRL	$V_{SS} - 0.3$	$V_{SS} + 7.0$	V	*1
Input voltage	$V_I$	$V_{SS} - 0.3$	$V_{CC} + 0.3$	V	*2
Output voltage	$V_O$	$V_{SS} - 0.3$	$V_{CC} + 0.3$	V	*2
"L" level maximum output current	$I_{OL}$	—	15	mA	*3
"L" level average output current	$I_{OLAV}$	—	4	mA	*4
"L" level total maximum output current	$\Sigma I_{OL}$	—	100	mA	
"L" level total average output current	$\Sigma I_{OLAV}$	—	50	mA	*5
"H" level maximum output current	$I_{OH}$	—	-15	mA	*3
"H" level average output current	$I_{OHAV}$	—	-4	mA	*4
"H" level total maximum output current	$\Sigma I_{OH}$	—	-100	mA	
"H" level total average output current	$\Sigma I_{OHAV}$	—	-50	mA	*5
Power consumption	$P_D$	—	400	mW	
Operating temperature	$T_A$	-40	+85	°C	
Storage temperature	$T_{stg}$	-55	+150	°C	

\*1:  $AV_{CC}$  shall never exceed  $V_{CC}$ . AVRH shall never exceed  $V_{CC}$  and  $AV_{CC}$ . Also, AVRL shall never exceed  $V_{CC}$ ,  $AV_{CC}$  and AVRH.

\*2:  $V_I$  and  $V_O$  shall never exceed  $V_{CC} + 0.3\text{ V}$ .

\*3: The maximum output current is a peak value for a corresponding pin.

\*4: Average output current is an average current value observed for a 100 ms period for a corresponding pin.

\*5: Total average current is an average current value observed for a 100 ms period for all corresponding pins.

WARNING: Semiconductor devices can be permanently damaged by application of stress (voltage, current, temperature, etc.) in excess of absolute maximum ratings. Do not exceed these ratings.

# MB90670/675 Series

## 2. Recommended Operating Conditions

( $V_{SS} = V_{SS} = 0.0\text{ V}$ )

Parameter	Symbol	Value		Unit	Remarks
		Min.	Max.		
Power supply voltage	$V_{CC}$	2.7	5.5	V	Normal operation
	$V_{CC}$	2.0	5.5	V	Retains status at the time of operation stop
Operating temperature	$T_A$	-40	+85	°C	

**WARNING:** The recommended operating conditions are required in order to ensure the normal operation of the semiconductor device. All of the device's electrical characteristics are warranted when the device is operated within these ranges.

Always use semiconductor devices within their recommended operating condition ranges. Operation outside these ranges may adversely affect reliability and could result in device failure.

No warranty is made with respect to uses, operating conditions, or combinations not represented on the data sheet. Users considering application outside the listed conditions are advised to contact their FUJITSU representatives beforehand.

# MB90670/675 Series

## 3. DC Characteristics

( $V_{CC} = V_{CC} = 2.7\text{ V to }5.5\text{ V}$ ,  $V_{SS} = V_{SS} = 0.0\text{ V}$ ,  $T_A = -40^\circ\text{C to }+85^\circ\text{C}$ )

Parameter	Symbol	Pin name	Condition	Value			Unit	Remarks
				Min.	Typ.	Max.		
"H" level input voltage	$V_{IH}$	Pins other than $V_{IHS}$ and $V_{IHM}$	—	$0.7 V_{CC}$	—	$V_{CC} + 0.3$	V	
	$V_{IHS}$	Hysteresis input pins P24 to P27, P40 to P47, P60 to P67, P70 to P77, P80, $\overline{HST}$ , $\overline{RST}$		$0.8 V_{CC}$	—	$V_{CC} + 0.3$	V	MB90670 series
	$V_{IHS}$	Hysteresis input pins P24 to P27, P40 to P47, P60 to P67, P70 to P77, P80 to P86, $\overline{HST}$ , $\overline{RST}$ , P90, P91, PA0 to PA7, PB0 to PB2		$0.8 V_{CC}$	—	$V_{CC} + 0.3$	V	MB90675 series
	$V_{IHM}$	MD pin input		$V_{CC} - 0.3$	—	$V_{CC} + 0.3$	V	
"L" level input voltage	$V_{IL}$	Pins other than $V_{ILS}$ and $V_{ILM}$	—	$V_{SS} - 0.3$	—	$0.3 V_{CC}$	V	
	$V_{ILS}$	Hysteresis input pins P24 to P27, P40 to P47, P60 to P67, P70 to P77, P80, $\overline{HST}$ , $\overline{RST}$		$V_{SS} - 0.3$	—	$0.2 V_{CC}$	V	MB90670 series
	$V_{ILS}$	Hysteresis input pins P24 to P27, P40 to P47, P60 to P67, P70 to P77, P80 to P86, $\overline{HST}$ , $\overline{RST}$ , P90, P91, PA0 to PA7, PB0 to PB2		$V_{SS} - 0.3$	—	$0.2 V_{CC}$	V	MB90675 series
	$V_{ILM}$	MD pin input		$V_{SS} - 0.3$	—	$V_{SS} + 0.3$	V	
"H" level output voltage	$V_{OH}$	Other than P50 to P57	$V_{CC} = 4.5\text{ V}$ $I_{OH} = -4.0\text{ mA}$	$V_{CC} - 0.5$	—	—	V	
	$V_{OH}$	Other than P50 to P57	$V_{CC} = 2.7\text{ V}$ $I_{OH} = -1.6\text{ mA}$	$V_{CC} - 0.3$	—	—	V	
"L" level output voltage	$V_{OL}$	All output pins	$V_{CC} = 4.5\text{ V}$ $I_{OL} = 4.0\text{ mA}$	—	—	0.4	V	
	$V_{OL}$	All output pins	$V_{CC} = 2.7\text{ V}$ $I_{OL} = 2.0\text{ mA}$	—	—	0.4	V	
Open-drain output leakage current	$I_{leak}$	P50 to P57, P90, P91*1	—	—	0.1	10	$\mu\text{A}$	

(Continued)

# MB90670/675 Series

(Continued)

( $AV_{CC} = V_{CC} = 2.7\text{ V to }5.5\text{ V}$ ,  $AV_{SS} = V_{SS} = 0.0\text{ V}$ ,  $T_A = -40^\circ\text{C to }+85^\circ\text{C}$ )

Parameter	Symbol	Pin name	Condition	Value			Unit	Remarks
				Min.	Typ.	Max.		
Input leakage current	$I_{IL}$	Other than P50 to P57, P90 and P91	$V_{CC} = 5.5\text{ V}$ $V_{SS} < V_I < V_{CC}$	-10	—	10	$\mu\text{A}$	
Pull-up resistance	R	—	$V_{CC} = 5.0\text{ V}$	25	45	100	$\text{k}\Omega$	
	R	—	$V_{CC} = 3.0\text{ V}$	40	95	200	$\text{k}\Omega$	
Pull-down resistance	R	—	$V_{CC} = 5.0\text{ V}$	25	50	200	$\text{k}\Omega$	
	R	—	$V_{CC} = 3.0\text{ V}$	40	100	400	$\text{k}\Omega$	
Power supply current	$I_{CC}$	—	Internal operation at 16 MHz $V_{CC}$ at 5.0 V	—	50	70	mA	Normal operation*2
	$I_{CCS}$	—	Internal operation at 16 MHz $V_{CC}$ at 5.0 V	—	10	30	mA	In sleep mode*2
	$I_{CC}$	—	Internal operation at 8 MHz $V_{CC}$ at 3.0 V	—	12	20	mA	Normal operation*2
	$I_{CCS}$	—	Internal operation at 8 MHz $V_{CC}$ at 3.0 V	—	2.5	10	mA	In sleep mode*2
	$I_{CCH}$	—	$T_A = +25^\circ\text{C}$	—	0.1	10	$\mu\text{A}$	In stop mode and hardware standby mode*2
Input capacitance	$C_{IN}$	Other than $AV_{CC}$ , $AV_{SS}$ , $V_{CC}$ , $V_{SS}$	—	—	10	—	pF	

\*1: Only MB90675 series has P90 and P91 pins.

\*2: The current value is preliminary value and may be subject to change for enhanced characteristics without previous notice.

# MB90670/675 Series

## 4. AC Characteristics

### (1) Reset Input Timing, Hardware Standby Input Timing

( $A_{V_{CC}} = V_{CC} = 2.7 \text{ V to } 5.5 \text{ V}$ ,  $A_{V_{SS}} = V_{SS} = 0.0 \text{ V}$ ,  $T_A = -40^\circ\text{C to } +85^\circ\text{C}$ )

Parameter	Symbol	Pin name	Condition	Value		Unit	Remarks
				Min.	Max.		
Reset input time	$t_{RSTL}$	$\overline{RST}$	—	16 $t_{CP}^*$	—	ns	
Hardware standby input time	$t_{HSTL}$	$\overline{HST}$		16 $t_{CP}^*$	—	ns	

\*: For  $t_{CP}$  (internal operating clock cycle time), refer to “(3) Clock Timings.”

www.DataSheet4U.com

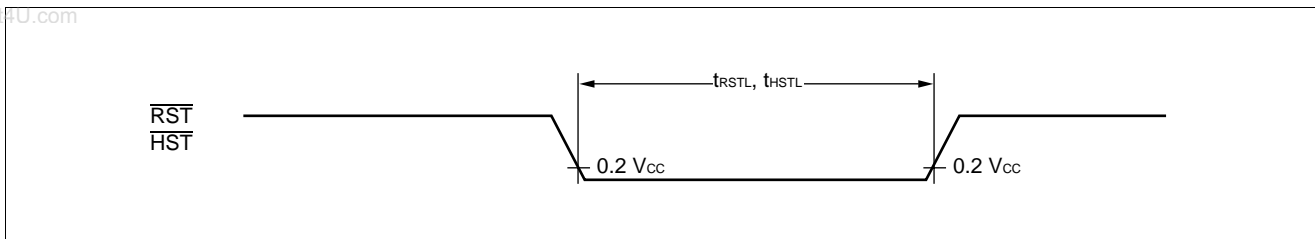

#### • Measurement conditions for AC ratings

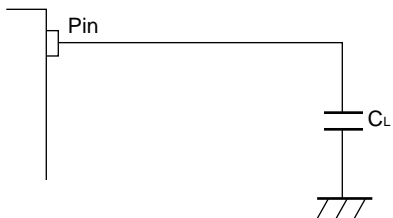

$C_L$  is a load capacitance connected to a pin under test.

CLK, ALE:  $C_L = 30 \text{ pF}$

Address data bus (AD15 to AD00),  $\overline{RD}$ ,  $\overline{WR}$ :  $C_L = 80 \text{ pF}$

# MB90670/675 Series

## (2) Specification for Power-on Reset

( $A_{V_{SS}} = V_{SS} = 0.0 \text{ V}$ ,  $T_A = -40^\circ\text{C}$  to  $+85^\circ\text{C}$ )

Parameter	Symbol	Pin name	Condition	Value		Unit	Remarks
				Min.	Max.		
Power supply rising time	$t_R$	$V_{CC}$	—	—	30	ms	*
Power supply cut-off time	$t_{OFF}$	$V_{CC}$	—	1	—	ms	Due to repeated operations

\*:  $V_{CC}$  must be kept lower than 0.2 V before power-on.

Notes : • The above ratings are values for causing a power-on reset.

www.DataSheet4U.com

- When  $\overline{HST}$  is set to "L" level, apply power according to this table to cause a power-on reset irrespective of whether or not a power-on reset is required.
- For built-in resources in the device, re-apply power to the resources to cause a power-on reset.
- There are internal registers which can be initialized only by a power-on reset. Apply power according to this rating to ensure initialization of the registers.

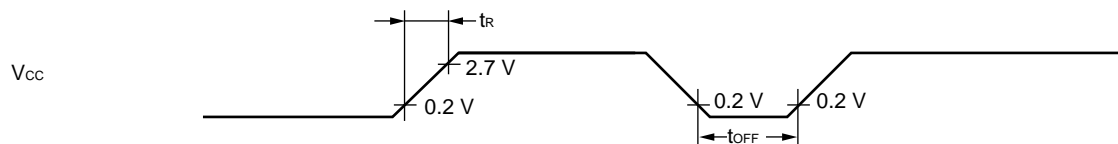

Sudden changes in the power supply voltage may cause a power-on reset.

To change the power supply voltage while the device is in operation, it is recommended to raise the voltage smoothly to suppress fluctuations as shown below.

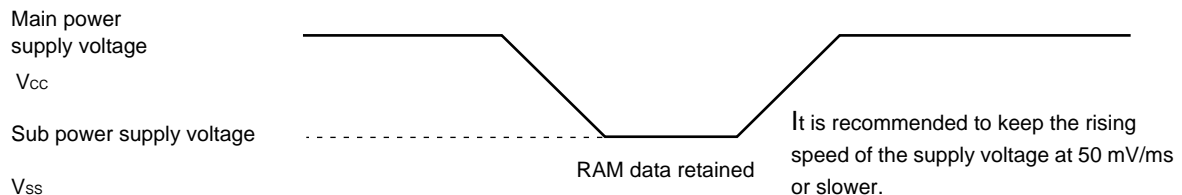

# MB90670/675 Series

## (3) Clock Timing

- Operation at 5.0 V ± 10%

(AV<sub>SS</sub> = V<sub>SS</sub> = 0.0 V, T<sub>A</sub> = -40°C to +85°C)

Parameter	Symbol	Pin name	Condition	Value			Unit	Remarks
				Min.	Typ.	Max.		
Clock frequency	F <sub>C</sub>	X0, X1	—	3	—	32	MHz	
Clock cycle time	t <sub>c</sub>	X0, X1		31.25	—	333	ns	
Input clock pulse width	P <sub>WH</sub> , P <sub>WL</sub>	X0		10	—	—	ns	Recommended duty ratio of 30% to 70%
Input clock rising/falling time	t <sub>CR</sub> , t <sub>CF</sub>	X0		—	—	5	ns	
Internal operating clock frequency	f <sub>CP</sub>	—		1.5	—	16	MHz	
Internal operating clock cycle time	t <sub>CP</sub>	—		62.5	—	666	ns	
Frequency fluctuation rate locked	Δf	P37/CLK		—	—	3	%	*

\*: The frequency fluctuation rate is the maximum deviation rate of the preset center frequency when the multiplied PLL signal is locked.

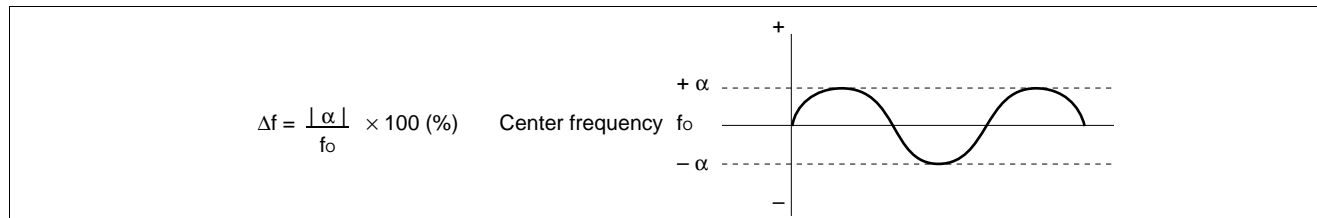

The PLL frequency deviation changes periodically from the preset frequency “(about CLK × (1CYC to 50 CYC))”, thus minimizing the chance of worst values to be repeated (errors are minimal and negligible for pulses with long intervals).



# MB90670/675 Series

• Operation at  $V_{CC} = 2.7\text{ V}$  (minimum value)

( $A_{V_{SS}} = V_{SS} = 0.0\text{ V}$ ,  $T_A = -40^\circ\text{C}$  to  $+85^\circ\text{C}$ )

Parameter	Symbol	Pin name	Condi- tion	Value			Unit	Remarks
				Min.	Typ.	Max.		
Clock frequency	$F_C$	X0, X1	—	3	—	16	MHz	
Clock cycle time	$t_c$	X0, X1		62.5	—	333	ns	
Input clock pulse width	$P_{WH}, P_{WL}$	X0		20	—	—	ns	Recommended duty ratio of 30% to 70%
Input clock rising/falling time	$t_{CR}, t_{CF}$	X0		—	—	5	ns	
Internal operating clock frequency	$f_{CP}$	—		1.5	—	8	MHz	
Internal operating clock cycle time	$t_{CP}$	—		125	—	666	ns	
Frequency fluctuation rate locked	$\Delta f$	P37/CLK		—	—	3	%	*

\*: The frequency fluctuation rate is the maximum deviation rate of the preset center frequency when the multiplied PLL signal is locked.

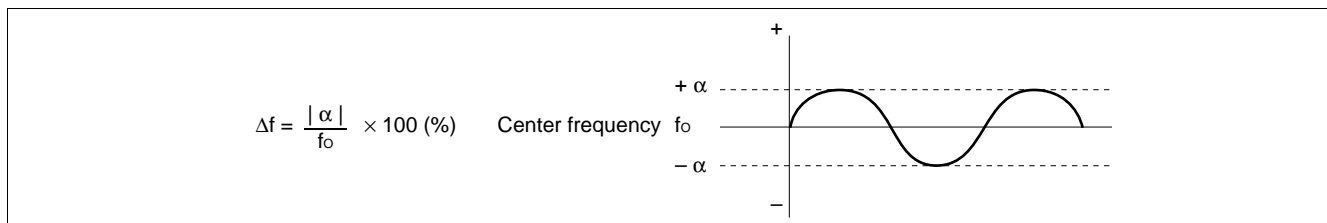

The PLL frequency deviation changes periodically from the preset frequency “(about  $CLK \times (1CYC$  to  $50\text{ CYC})$ ”, thus minimizing the chance of worst values to be repeated (errors are minimal and negligible for pulses with long intervals).

# MB90670/675 Series

## • Clock timing

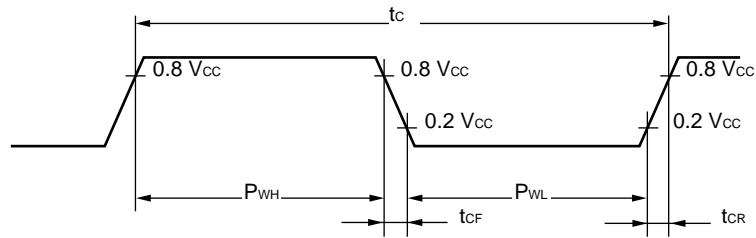

## • PLL operation guarantee range

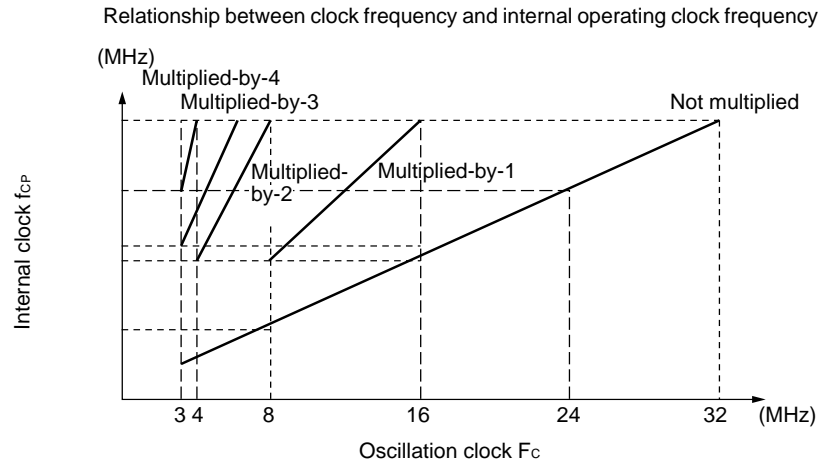
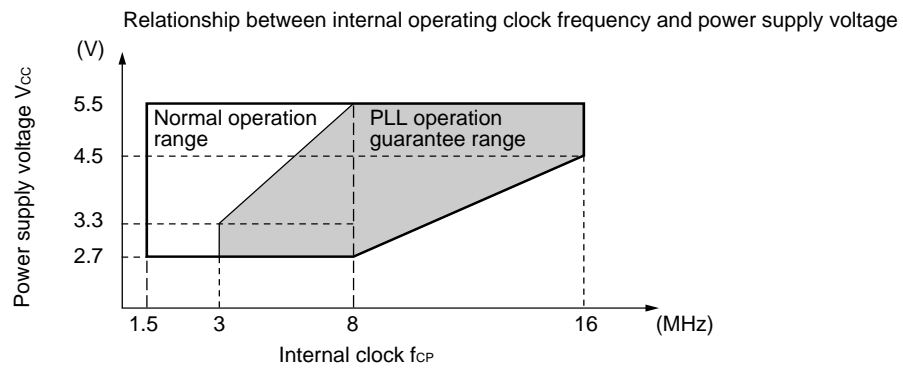

Note : The operation guarantee range on the lower voltage is 2.7 V for the evaluation chips.

The AC ratings are measured for the following measurement reference voltages.

## • Input signal waveform

Hysteresis input pin



Pins other than hysteresis input/MD input

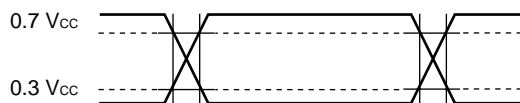

## • Output signal waveform

Output pin

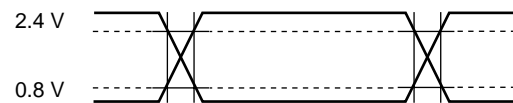

## (4) Recommended Resonator Manufacturers

- Sample application of piezoelectric resonator (FAR family)

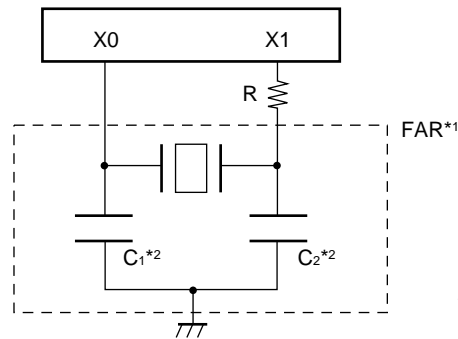

\*1: FUJITSU MEDIA DEVICES Acoustic Resonator

FAR part number (built-in capacitor type)	Frequency (MHz)	Damping resistor	Initial deviation of FAR frequen- cy ( $T_A = +25^\circ\text{C}$ )	Temperature char- acteristics of FAR frequency ( $T_A = -20^\circ\text{C}$ to $+60^\circ\text{C}$ )	Loading ca- pacitors*2
FAR-C4□C-2000-□20	2.00	510 $\Omega$	$\pm 0.5\%$	$\pm 0.5\%$	Built-in
FAR-C4□A-4000-□01	4.00	—	$\pm 0.5\%$	$\pm 0.5\%$	Built-in
FAR-C4□B-4000-□02	4.00	—	$\pm 0.5\%$	$\pm 0.5\%$	Built-in
FAR-C4□B-4000-□00	4.00	—	$\pm 0.5\%$	$\pm 0.5\%$	Built-in
FAR-C4□B-8000-□02	8.00	—	$\pm 0.5\%$	$\pm 0.5\%$	Built-in
FAR-C4□B-12000-□02	12.00	—	$\pm 0.5\%$	$\pm 0.5\%$	Built-in
FAR-C4□B-16000-□02	16.00	—	$\pm 0.5\%$	$\pm 0.5\%$	Built-in
FAR-C4□B-20000-L14B	20.00	—	$\pm 0.5\%$	$\pm 0.5\%$	Built-in
FAR-C4□B-24000-L14A	24.00	—	$\pm 0.5\%$	$\pm 0.5\%$	Built-in

Inquiry: FUJITSU MEDIA DEVICES LIMITED

# MB90670/675 Series

## • Sample application of ceramic resonator

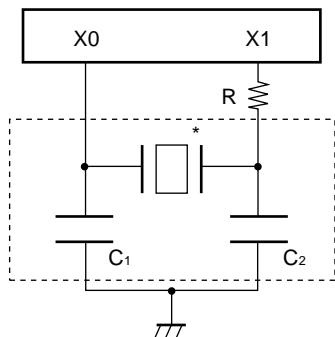

## • Mask ROM product

Resonator manufacturer	Resonator	Frequency (MHz)	C <sub>1</sub> (pF)	C <sub>2</sub> (pF)	R
Kyocera Corporation	KBR-2.0MS	2.00	150	150	Not required
	PBRC-2.00A	2.00	150	150	Not required
	KBR-4.0MSA	4.00	33	33	680 Ω
	KBR-4.0MKS	4.00	Built-in	Built-in	680 Ω
	PBRC4.00A	4.00	33	33	680 Ω
	PBRC4.00B	4.00	Built-in	Built-in	680 Ω
	KBR-6.0MSA	6.00	33	33	Not required
	KBR-6.0MKS	6.00	Built-in	Built-in	Not required
	PBRC6.00A	6.00	33	33	Not required
	PBRC6.00B	6.00	Built-in	Built-in	Not required
	KBR-8.0M	8.00	33	33	560 Ω
	PBRC8.00A	8.00	33	33	Not required
	PBRC8.00B	8.00	Built-in	Built-in	Not required
	KBR-10.0M	10.00	33	33	330 Ω
	PBRC10.00B	10.00	Built-in	Built-in	680 Ω
	KBR-12.0M	12.00	33	33	330 Ω
PBRC-12.00B	12.00	Built-in	Built-in	680 Ω	
Murata Mfg. Co., Ltd.	CSA2.00MG040	2.00	100	100	Not required
	CST2.00MG040	2.00	Built-in	Built-in	Not required
	CSA4.00MG040	4.00	100	100	Not required
	CST4.00MGW040	4.00	Built-in	Built-in	Not required
	CSA6.00MG	6.00	30	30	Not required
	CST6.00MGW	6.00	Built-in	Built-in	Not required
	CSA8.00MTZ	8.00	30	30	Not required
	CST8.00MTW	8.00	Built-in	Built-in	Not required

(Continued)

# MB90670/675 Series

(Continued)

Resonator manufacturer	Resonator	Frequency (MHz)	C <sub>1</sub> (pF)	C <sub>2</sub> (pF)	R
Murata Mfg. Co., Ltd.	CSA10.0MTZ	10.00	30	30	Not required
	CST10.0MTW	10.00	Built-in	Built-in	Not required
	CSA12.0MTZ	12.00	30	30	Not required
	CST12.0MTW	12.00	Built-in	Built-in	Not required
	CSA16.00MXZ040	16.00	15	15	Not required
	CST16.00MXW0C3	16.00	Built-in	Built-in	Not required
	CSA20.00MXZ040	20.00	10	10	Not required
	CSA24.00MXZ040	24.00	5	5	Not required
	CST24.00MXW0H1	24.00	Built-in	Built-in	Not required
	CSA32.00MXZ040	32.00	5	5	Not required
CST32.00MXW040	32.00	Built-in	Built-in	Not required	
TDK Corporation	FCR4.0MC5	4.00	Built-in	Built-in	Not required

• One-time product

Resonator manufacturer	Resonator	Frequency (MHz)	C <sub>1</sub> (pF)	C <sub>2</sub> (pF)	R
Murata Mfg. Co., Ltd.	CSTCS4.00MG0C5	4.0	Built-in	Built-in	Not required
	CST8.00MTW	8.00	Built-in	Built-in	Not required
	CSACS8.00MT	8.00	30	30	Not required
	CSA10.0MTZ	10.00	30	30	Not required
	CST10.0MTW	10.00	Built-in	Built-in	Not required
TDK Corporation	FCR4.0MC5	4.00	Built-in	Built-in	Not required

Inquiry:Kyocera Corporation

- AVX Corporation  
North American Sales Headquarters: TEL 1-803-448-9411
- AVX Limited  
European Sales Headquarters: TEL 44-1252-770000
- AVX/Kyocera H.K. Ltd.  
Asian Sales Headquarters: TEL 852-363-3303
- Murata Mfg. Co., Ltd.
  - Murata Electronics North America, Inc.: TEL 1-404-436-1300
  - Murata Europe Management GmbH: TEL 49-911-66870
  - Murata Electronics Singapore (Pte.) Ltd.: TEL 65-758-4233
- TDK Corporation
  - TDK Corporation of America  
Chicago Regional Office: TEL 1-708-803-6100
  - TDK Electronics Europe GmbH  
Components Division: TEL 49-2102-9450
  - TDK Singapore (PTE) Ltd.: TEL 65-273-5022
  - TDK Hongkong Co., Ltd.: TEL 852-736-2238
  - Korea Branch, TDK Corporation: TEL 82-2-554-6633

# MB90670/675 Series

## (5) Clock Output Timing

( $V_{CC} = V_{CC} = 2.7\text{ V to }5.5\text{ V}$ ,  $V_{SS} = V_{SS} = 0.0\text{ V}$ ,  $T_A = -40^\circ\text{C to }+85^\circ\text{C}$ )

Parameter	Symbol	Pin name	Condition	Value		Unit	Remarks
				Min.	Max.		
Cycle time	$t_{CYC}$	CLK	—	$1 t_{CP}^*$	—	ns	
CLK $\uparrow \rightarrow$ CLK $\downarrow$	$t_{CHCL}$	CLK	$V_{CC} = 5.0\text{ V} \pm 10\%$	$1 t_{CP}^*/2 - 20$	$1 t_{CP}^*/2 + 20$	ns	$5.0\text{ V} \pm 10\%$ is $\pm 20$
	$t_{CHCL}$	CLK	$V_{CC} = 3.0\text{ V} \pm 10\%$	$1 t_{CP}^*/2 - 35$	$1 t_{CP}^*/2 + 35$	ns	$3.0\text{ V} \pm 10\%$ is $\pm 35$

\*: For  $t_{CP}$  (internal operating clock cycle time), refer to "(3) Clock Timing".

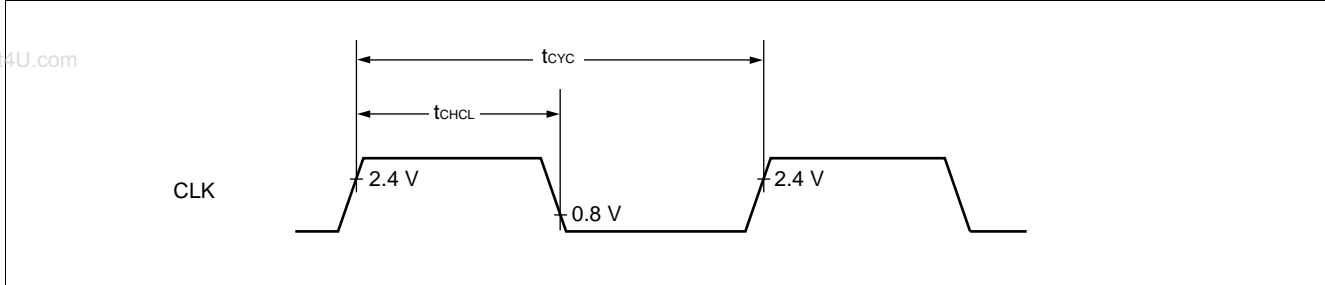

# MB90670/675 Series

## (6) Bus Read Timing

( $V_{CC} = V_{CC} = 2.7\text{ V to }5.5\text{ V}$ ,  $V_{SS} = V_{SS} = 0.0\text{ V}$ ,  $T_A = -40^\circ\text{C to }+85^\circ\text{C}$ )

Parameter	Symbol	Pin name	Condition	Value		Unit	Remarks
				Min.	Max.		
ALE pulse width	$t_{LHLL}$	ALE	$V_{CC} = 5.0\text{ V} \pm 10\%$	$1\ t_{CP}^*/2 - 20$	—	ns	
	$t_{LHLL}$	ALE	$V_{CC} = 3.0\text{ V} \pm 10\%$	$1\ t_{CP}^*/2 - 35$	—	ns	
Effective address → ALE ↓ time	$t_{AVLL}$	AD15 to AD00	$V_{CC} = 5.0\text{ V} \pm 10\%$	$1\ t_{CP}^*/2 - 25$	—	ns	
	$t_{AVLL}$	AD15 to AD00	$V_{CC} = 3.0\text{ V} \pm 10\%$	$1\ t_{CP}^*/2 - 40$	—	ns	
ALE ↓ → address effective time	$t_{LLAX}$	AD15 to AD00	—	$1\ t_{CP}^*/2 - 15$	—	ns	
Effective address → $\overline{RD}$ ↓ time	$t_{AVRL}$	AD15 to AD00	—	$1\ t_{CP}^* - 15$	—	ns	
Effective address → read data time	$t_{AVDV}$	AD15 to AD00	$V_{CC} = 5.0\text{ V} \pm 10\%$	—	$5\ t_{CP}^*/2 - 60$	ns	
	$t_{AVDV}$	AD15 to AD00	$V_{CC} = 3.0\text{ V} \pm 10\%$	—	$5\ t_{CP}^*/2 - 80$	ns	
$\overline{RD}$ pulse width	$t_{RLRH}$	$\overline{RD}$	—	$3\ t_{CP}^*/2 - 20$	—	ns	
$\overline{RD}$ ↓ → read data time	$t_{RLDV}$	AD15 to AD00	$V_{CC} = 5.0\text{ V} \pm 10\%$	—	$3\ t_{CP}^*/2 - 60$	ns	
	$t_{RLDV}$	AD15 to AD00	$V_{CC} = 3.0\text{ V} \pm 10\%$	—	$3\ t_{CP}^*/2 - 80$	ns	
$\overline{RD}$ ↑ → data hold time	$t_{RHDX}$	AD15 to AD00	—	0	—	ns	
$\overline{RD}$ ↑ → ALE ↑ time	$t_{RH LH}$	$\overline{RD}$ , ALE	—	$1\ t_{CP}^*/2 - 15$	—	ns	
$\overline{RD}$ ↑ → address disappear time	$t_{RHAX}$	$\overline{RD}$ , A19 to A16	—	$1\ t_{CP}^*/2 - 10$	—	ns	
Effective address → CLK ↑ time	$t_{AVCH}$	CLK, A19 to A16	—	$1\ t_{CP}^*/2 - 20$	—	ns	
$\overline{RD}$ ↓ → CLK ↑ time	$t_{RLCH}$	$\overline{RD}$ , CLK	—	$1\ t_{CP}^*/2 - 20$	—	ns	

\* : For  $t_{CP}$  (internal operating clock cycle time), refer to “(3) Clock Timing”.

# MB90670/675 Series

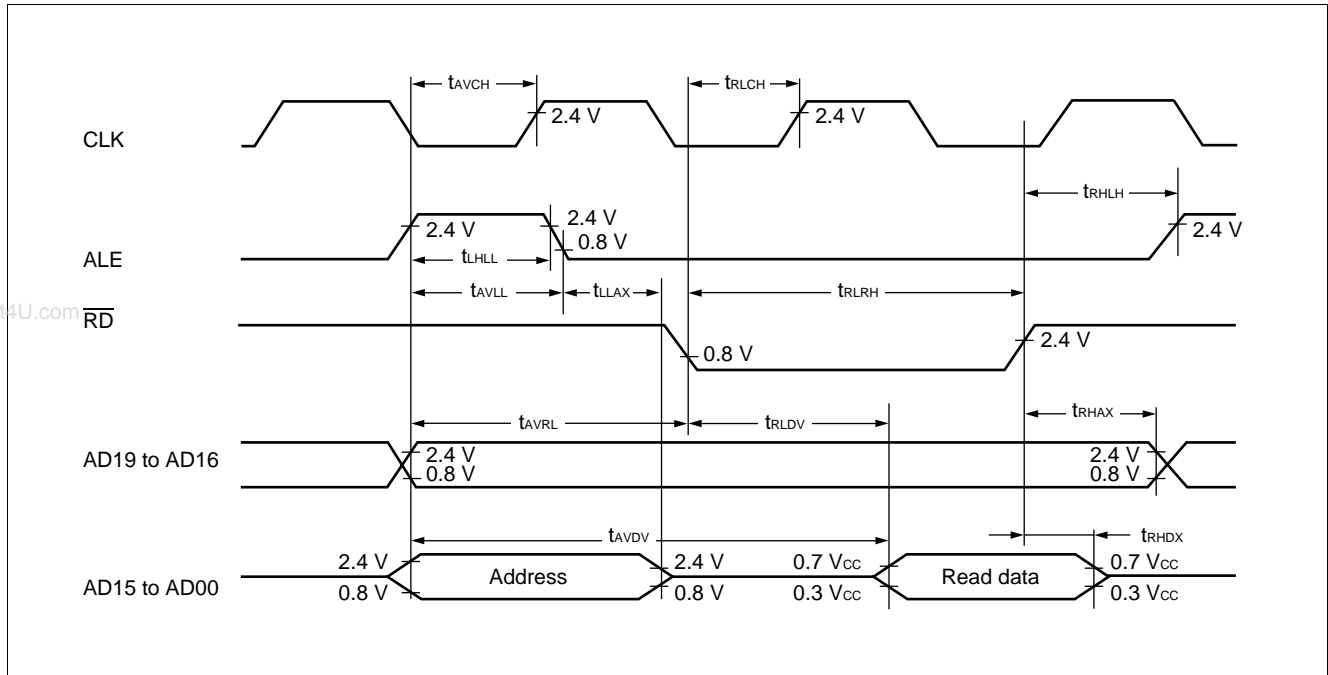



# MB90670/675 Series

## (7) Bus Write Timing

( $V_{CC} = V_{CC} = 2.7\text{ V to }5.5\text{ V}$ ,  $V_{SS} = V_{SS} = 0.0\text{ V}$ ,  $T_A = -40^\circ\text{C to }+85^\circ\text{C}$ )

Parameter	Symbol	Pin name	Condition	Value		Unit	Remarks
				Min.	Max.		
Effective address $\rightarrow \overline{WR} \downarrow$ time	$t_{AVWL}$	A19 to A00	—	$1 t_{CP} - 15$	—	ns	
$\overline{WR}$ pulse width	$t_{WLWH}$	$\overline{WR}$		$3 t_{CP}^*/2 - 20$	—	ns	
Write data $\rightarrow \overline{WR} \uparrow$ time	$t_{DVWH}$	AD15 to AD00		$3 t_{CP}^*/2 - 20$	—	ns	
$\overline{WR} \uparrow \rightarrow$ data hold time	$t_{WHDX}$	AD15 to AD00	$V_{CC} = 5.0\text{ V} \pm 10\%$	20	—	ns	
		AD15 to AD00	$V_{CC} = 3.0\text{ V} \pm 10\%$	30	—	ns	
$\overline{WR} \uparrow \rightarrow$ address disappear time	$t_{WHAX}$	A19 to A00	—	$1 t_{CP}^*/2 - 10$	—	ns	
$\overline{WR} \uparrow \rightarrow$ ALE $\uparrow$ time	$t_{WHLH}$	$\overline{WRL}$ , ALE		$1 t_{CP}^*/2 - 15$	—	ns	
$\overline{WR} \downarrow \rightarrow$ CLK $\uparrow$ time	$t_{WLCH}$	$\overline{WRH}$ , CLK		$1 t_{CP}^*/2 - 20$	—	ns	

\*: For  $t_{CP}$  (internal operating clock cycle time), refer to "(3) Clock Timing".

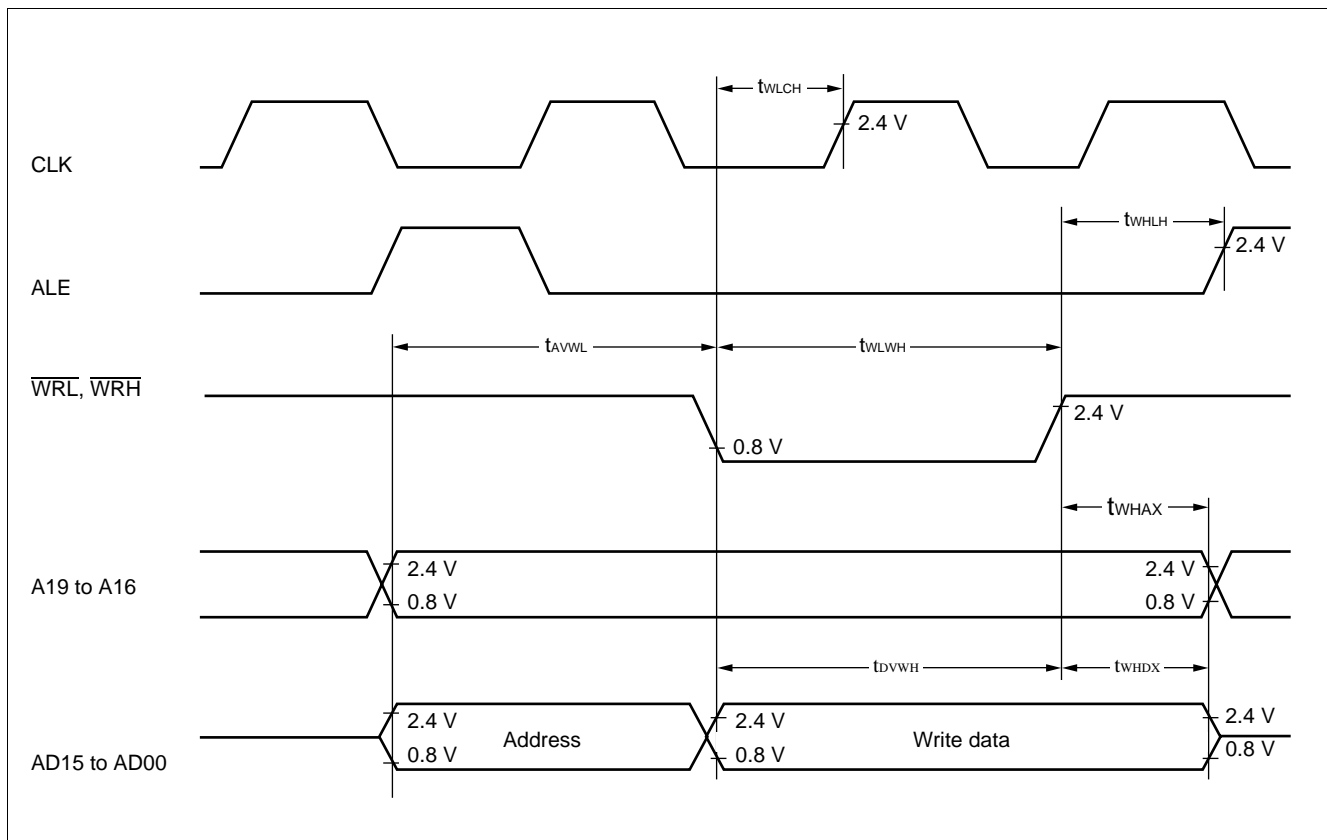

# MB90670/675 Series

## (8) Ready Input Timing

( $AV_{CC} = V_{CC} = 2.7\text{ V to }5.5\text{ V}$ ,  $AV_{SS} = V_{SS} = 0.0\text{ V}$ ,  $T_A = -40^\circ\text{C to }+85^\circ\text{C}$ )

Parameter	Symbol	Pin name	Condition	Value		Unit	Remarks
				Min.	Max.		
RDY setup time	t <sub>RYHS</sub>	RDY	V <sub>CC</sub> = 5.0 V ±10%	45	—	ns	
	t <sub>RYHS</sub>	RDY	V <sub>CC</sub> = 3.0 V ±10%	70	—	ns	
RDY hold time	t <sub>RYHH</sub>	RDY	—	0	—	ns	

Note : Use the auto-ready function when the setup time for the rising of the RDY signal is not sufficient.

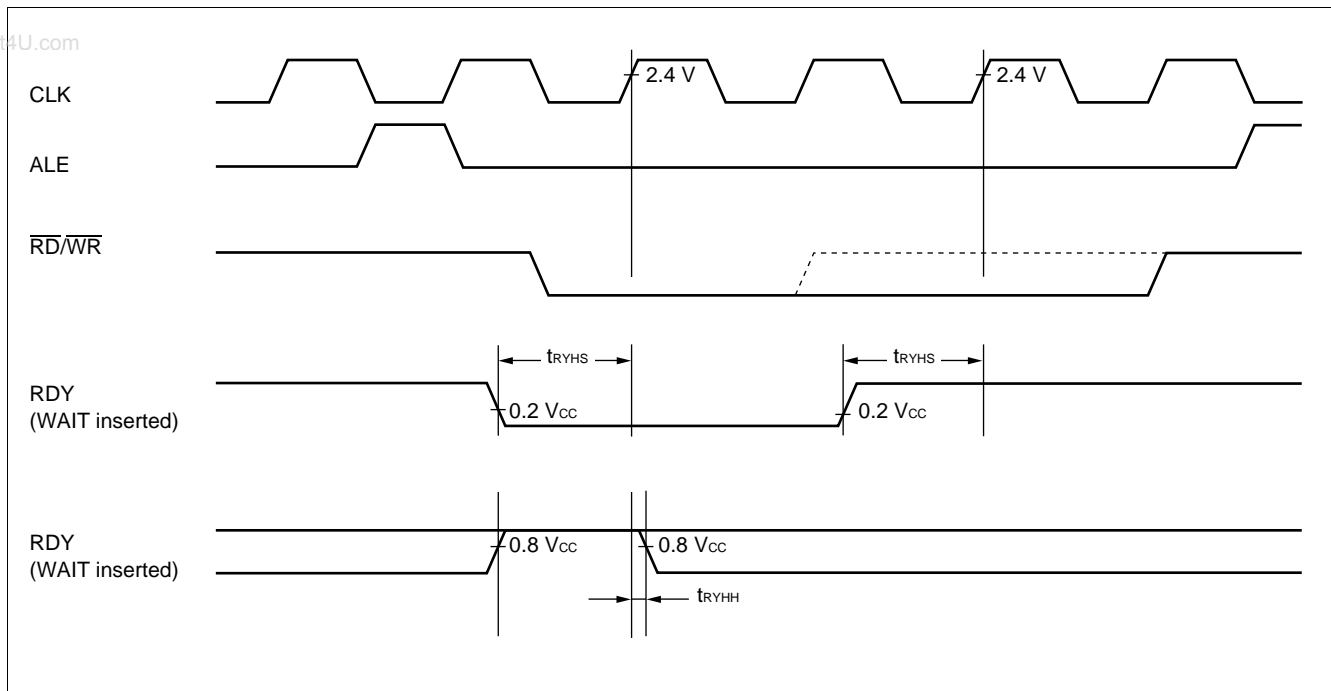

## (9) Hold Timing

( $AV_{CC} = V_{CC} = 2.7\text{ V to }5.5\text{ V}$ ,  $AV_{SS} = V_{SS} = 0.0\text{ V}$ ,  $T_A = -40^\circ\text{C to }+85^\circ\text{C}$ )

Parameter	Symbol	Pin name	Condition	Value		Unit	Remarks
				Min.	Max.		
Pins in floating status → $\overline{HAK} \downarrow$ time	t <sub>XHAL</sub>	$\overline{HAK}$	—	30	1 t <sub>CP</sub> *	ns	
$\overline{HAK} \uparrow$ → pin valid time	t <sub>HAHV</sub>	$\overline{HAK}$	—	1 t <sub>CP</sub> *	2 t <sub>CP</sub> *	ns	

\* : For t<sub>CP</sub> (internal operating clock cycle time), refer to “(3) Clock Timing”.

Note : More than 1 machine cycle is needed before  $\overline{HAK}$  changes after HRQ pin is fetched.

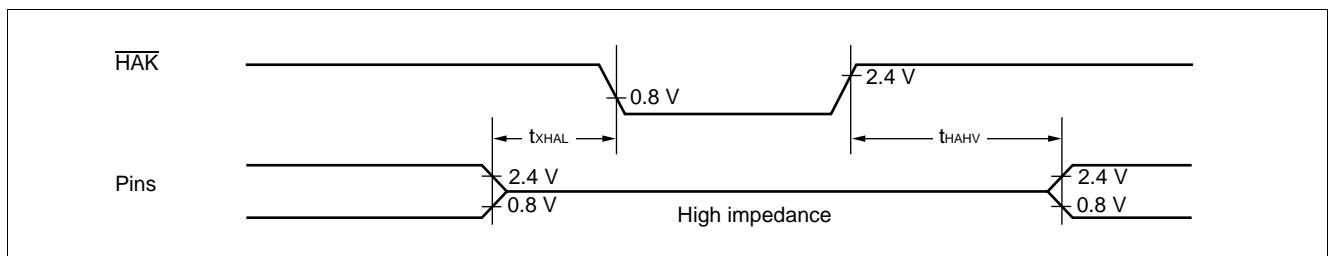

# MB90670/675 Series

## (10) UART0 Timing

( $V_{CC} = V_{CC} = 2.7\text{ V to } 5.5\text{ V}$ ,  $V_{SS} = V_{SS} = 0.0\text{ V}$ ,  $T_A = -40^\circ\text{C to } +85^\circ\text{C}$ )

Parameter	Symbol	Pin name	Condition	Value		Unit	Remarks
				Min.	Max.		
Serial clock cycle time	t <sub>SCYC</sub>	—	—	8 t <sub>CP</sub> *	—	ns	Internal shift clock mode C <sub>L</sub> = 80 pF + 1 TTL for an output pin
SCK ↓ → SOT delay time	t <sub>SLOV</sub>	—	V <sub>CC</sub> = 5.0 V ±10%	- 80	80	ns	
	t <sub>SLOV</sub>	—	V <sub>CC</sub> = 3.0 V ±10%	- 120	120	ns	
Valid SIN → SCK ↑	t <sub>IVSH</sub>	—	V <sub>CC</sub> = 5.0 V ±10%	100	—	ns	
	t <sub>IVSH</sub>	—	V <sub>CC</sub> = 3.0 V ±10%	200	—	ns	
SCK ↑ → valid SIN hold time	t <sub>SHIX</sub>	—	—	1 t <sub>CP</sub> *	—	ns	External shift clock mode C <sub>L</sub> = 80 pF + 1 TTL for an output pin
Serial clock "H" pulse width	t <sub>SHSL</sub>	—	—	4 t <sub>CP</sub> *	—	ns	
Serial clock "L" pulse width	t <sub>SLSH</sub>	—	—	4 t <sub>CP</sub> *	—	ns	
SCK ↓ → SOT delay time	t <sub>SLOV</sub>	—	V <sub>CC</sub> = 5.0 V ±10%	—	150	ns	
	t <sub>SLOV</sub>	—	V <sub>CC</sub> = 3.0 V ±10%	—	200	ns	
Valid SIN → SCK ↑	t <sub>IVSH</sub>	—	V <sub>CC</sub> = 5.0 V ±10%	60	—	ns	
	t <sub>IVSH</sub>	—	V <sub>CC</sub> = 3.0 V ±10%	120	—	ns	
SCK ↑ → valid SIN hold time	t <sub>SHIX</sub>	—	V <sub>CC</sub> = 5.0 V ±10%	60	—	ns	
	t <sub>SHIX</sub>	—	V <sub>CC</sub> = 3.0 V ±10%	120	—	ns	

\* : For t<sub>CP</sub> (internal operating clock cycle time), refer to "(3) Clock Timing".

Notes : • These are AC ratings in the CLK synchronous mode.

• C<sub>L</sub> is the load capacitor connected to pins while testing.

# MB90670/675 Series

## • Internal shift clock mode

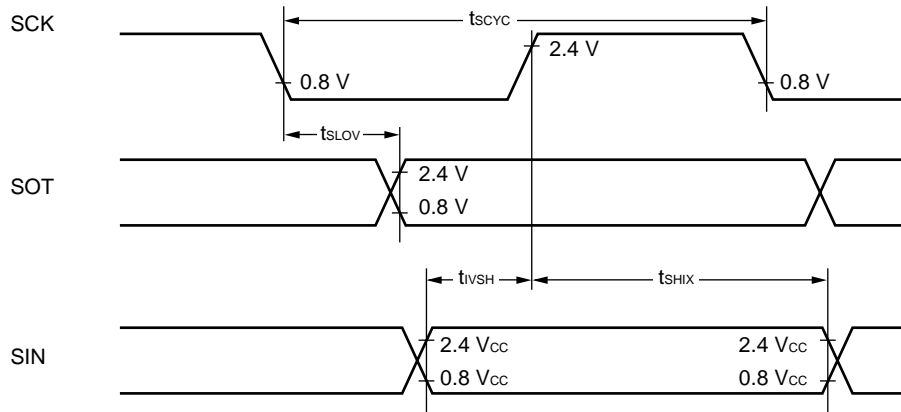

## • External shift clock mode

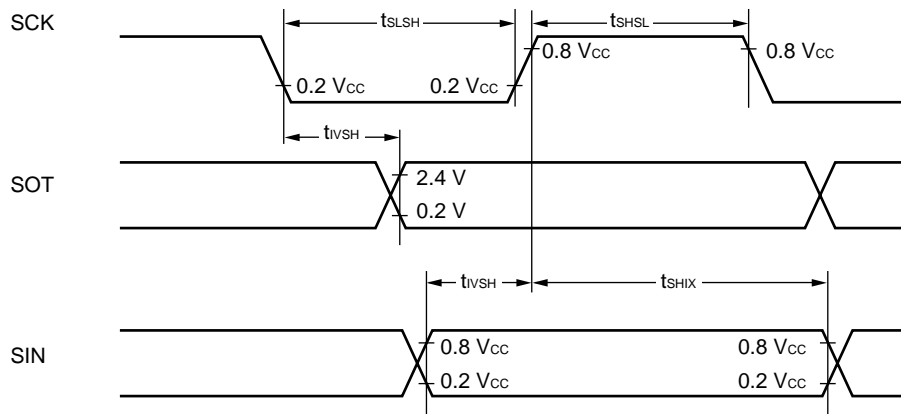

# MB90670/675 Series

## (11) UART1 Timing

( $A_{V_{CC}} = V_{CC} = 2.7\text{ V to }5.5\text{ V}$ ,  $A_{V_{SS}} = V_{SS} = 0.0\text{ V}$ ,  $T_A = -40^\circ\text{C to }+85^\circ\text{C}$ )

Parameter	Symbol	Pin name	Condition	Value		Unit	Remarks
				Min.	Max.		
Serial clock cycle time	t <sub>SCYC</sub>	—	—	8 t <sub>CP</sub> *	—	ns	Internal shift clock mode C <sub>L</sub> = 80 pF + 1 TTL for an output pin
SCK ↓ → SOT delay time	t <sub>SLOV</sub>	—	V <sub>CC</sub> = 5.0 V ±10%	- 80	80	ns	
	t <sub>SLOV</sub>	—	V <sub>CC</sub> = 3.0 V ±10%	- 120	120	ns	
Valid SIN → SCK ↑	t <sub>IVSH</sub>	—	V <sub>CC</sub> = 5.0 V ±10%	100	—	ns	
	t <sub>IVSH</sub>	—	V <sub>CC</sub> = 3.0 V ±10%	200	—	ns	
SCK ↑ → valid SIN hold time	t <sub>SHIX</sub>	—	—	1 t <sub>CP</sub> *	—	ns	External shift clock mode C <sub>L</sub> = 80 pF + 1 TTL for an output pin
Serial clock "H" pulse width	t <sub>SHSL</sub>	—	—	4 t <sub>CP</sub> *	—	ns	
Serial clock "L" pulse width	t <sub>SLSH</sub>	—	—	4 t <sub>CP</sub> *	—	ns	
SCK ↓ → SOT delay time	t <sub>SLOV</sub>	—	V <sub>CC</sub> = 5.0 V ±10%	—	150	ns	
	t <sub>SLOV</sub>	—	V <sub>CC</sub> = 3.0 V ±10%	—	200	ns	
Valid SIN → SCK ↑	t <sub>IVSH</sub>	—	V <sub>CC</sub> = 5.0 V ±10%	60	—	ns	
	t <sub>IVSH</sub>	—	V <sub>CC</sub> = 3.0 V ±10%	120	—	ns	
SCK ↑ → valid SIN hold time	t <sub>SHIX</sub>	—	V <sub>CC</sub> = 5.0 V ±10%	60	—	ns	
	t <sub>SHIX</sub>	—	V <sub>CC</sub> = 3.0 V ±10%	120	—	ns	

\* : For t<sub>CP</sub> (internal operating clock cycle time), refer to "(3) Clock Timing".

Notes : • These are AC ratings in the CLK synchronous mode.

- C<sub>L</sub> is the load capacitor connected to pins while testing.

# MB90670/675 Series

- Internal shift clock mode

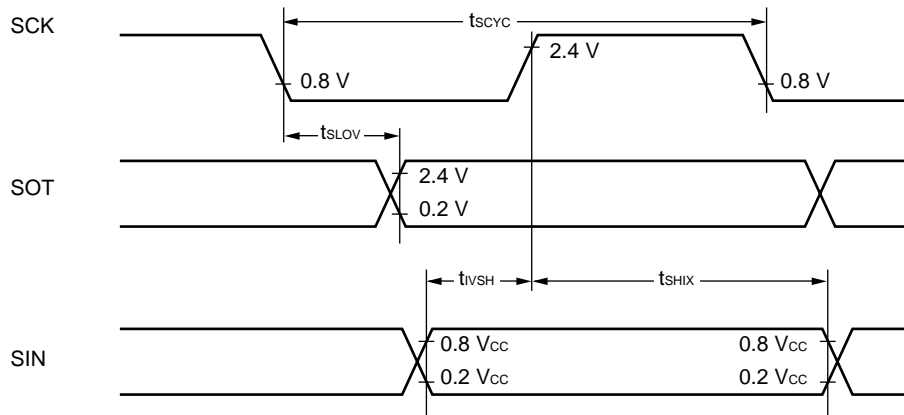

- External shift clock mode

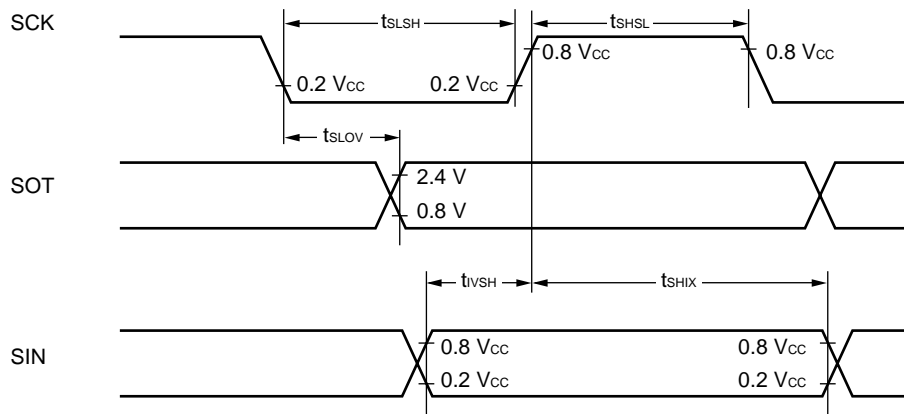

# MB90670/675 Series

## (12) Timer Input Timing

( $V_{CC} = V_{CC} = 2.7\text{ V to }5.5\text{ V}$ ,  $V_{SS} = V_{SS} = 0.0\text{ V}$ ,  $T_A = -40^\circ\text{C to }+85^\circ\text{C}$ )

Parameter	Symbol	Pin name	Condition	Value		Unit	Remarks
				Min.	Max.		
Input pulse width	$t_{TIWH}$ , $t_{TIWL}$	TIN0, TON1	—	$4 t_{CP}^*$	—	ns	

\* : For  $t_{CP}$  (internal operating clock cycle time), refer to “(3) Clock Timing”.

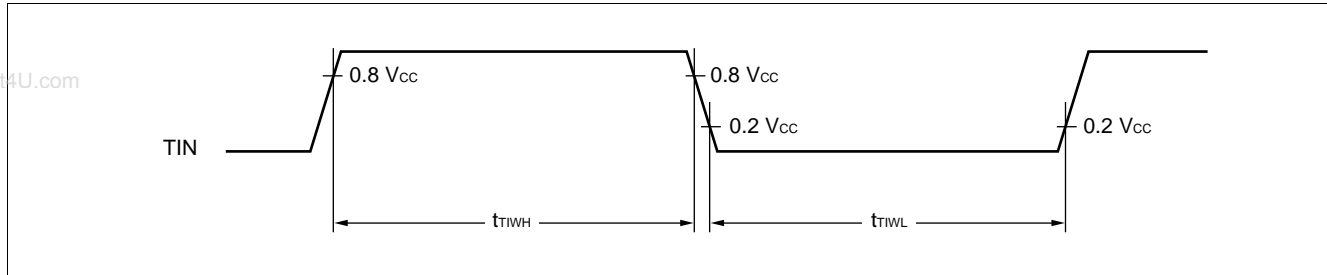

## (13) Timer Output Timing

( $V_{CC} = V_{CC} = 2.7\text{ V to }5.5\text{ V}$ ,  $V_{SS} = V_{SS} = 0.0\text{ V}$ ,  $T_A = -40^\circ\text{C to }+85^\circ\text{C}$ )

Parameter	Symbol	Pin name	Condition	Value		Unit	Remarks
				Min.	Max.		
CLK $\uparrow$ $\rightarrow$ T <sub>OUT</sub> transition time	$t_{TO}$	TOT0, TOT1	$V_{CC} = 5.0\text{ V} \pm 10\%$	30	—	ns	
	$t_{TO}$	TOT0, TOT1	$V_{CC} = 3.0\text{ V} \pm 10\%$	80	—	ns	

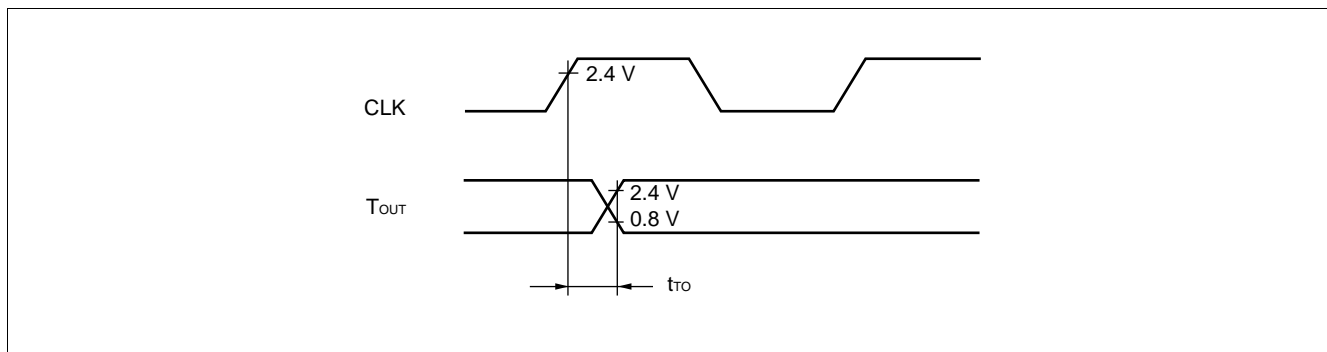

# MB90670/675 Series

## (14) I<sup>2</sup>C Timing

( $V_{CC} = V_{CC} = 5.0\text{ V} \pm 10\%$ ,  $V_{SS} = V_{SS} = 0.0\text{ V}$ ,  $T_A = -40^\circ\text{C}$  to  $+85^\circ\text{C}$ )

Parameter	Symbol	Pin name	Condition	Value		Unit	Remarks
				Min.	Max.		
SCL clock frequency	$f_{SCL}$	—	—	0	100	kHz	
Bus free time between stop and start conditions	$t_{BUS}$	—		4.7	—	$\mu\text{s}$	
Hold time (re-transmission) start	$t_{HDSTA}$	—		4.0	—	$\mu\text{s}$	The first clock pulse is generated after this period.
LOW status hold time of SCL clock	$t_{LOW}$	—		4.7	—	$\mu\text{s}$	
HIGH status hold time of SCL clock	$t_{HIGH}$	—		4.0	—	$\mu\text{s}$	
Setup time for conditions for starting re-transmission	$t_{SUSTA}$	—		4.7	—	$\mu\text{s}$	
Data hold time	$t_{HDDAT}$	—		0	—	$\mu\text{s}$	
Data setup time	$t_{SUDAT}$	—		250	—	ns	
Rising time of SDA and SCL signals	$t_R$	—		—	1000	ns	
Falling time of SDA and SCL signals	$t_F$	—		—	300	ns	
Setup time for stop conditions	$t_{SUSTO}$	—		4.0	—	$\mu\text{s}$	

Note : Only MB90675 series has I<sup>2</sup>C.

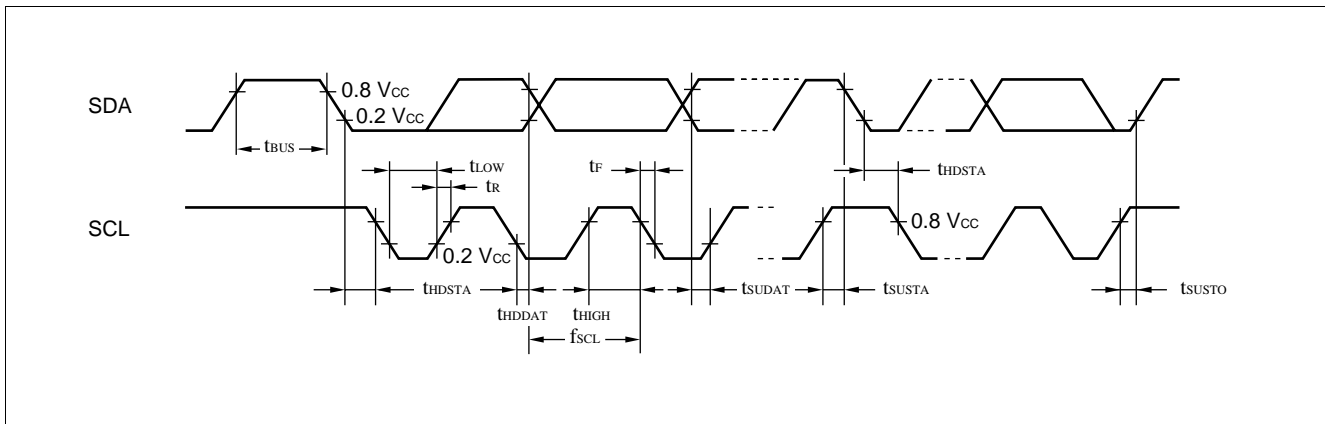



## 5. A/D Converter Electrical Characteristics

(AV<sub>CC</sub> = V<sub>CC</sub> = 2.7 V to 5.5 V, AV<sub>SS</sub> = V<sub>SS</sub> = 0.0 V, 2.7 V ≤ AVR<sub>H</sub> – AVR<sub>L</sub>, T<sub>A</sub> = –40°C to +85°C)

Parameter	Symbol	Pin name	Condition	Value			Unit
				Min.	Typ.	Max.	
Resolution	—	—	—	—	—	10	bit
Total error	—	—		—	—	±3.0	LSB
Linearity error	—	—		—	—	±2.0	LSB
Differential linearity error	—	—		—	—	±1.5	LSB
Zero transition voltage	V <sub>OT</sub>	AN0 to AN7		—	AVRL – 1.5 LSB	AVRL + 0.5 LSB	AVRL + 2.5 LSB
Full-scale transition voltage	V <sub>FST</sub>	AN0 to AN7	—	AVRH – 4.5 LSB	AVRH – 1.5 LSB	AVRH + 0.5 LSB	mV
Conversion time	—	—	V <sub>CC</sub> = 5.0 V ±10% at machine clock of 16 MHz	6.125	—	—	μs
	—	—	V <sub>CC</sub> = 3.0 V ±10% at machine clock of 8 MHz	12.25	—	—	μs
Analog port input current	I <sub>AIN</sub>	AN0 to AN7	—	—	0.1	10	μA
Analog input voltage	V <sub>AIN</sub>	AN0 to AN7		AVRL	—	AVRH	V
Reference voltage	—	AVRH		AVRL – 2.7	—	AV <sub>CC</sub>	V
	—	AVRL		0	—	AVRH – 2.7	V
Power supply current	I <sub>A</sub>	AV <sub>CC</sub>		—	—	3	—
	I <sub>AH</sub>	AV <sub>CC</sub>	Supply current when CPU stopped and A/D converter not in operation (V <sub>CC</sub> = AV <sub>CC</sub> = AVR <sub>H</sub> = 5.0 V)	—	—	5	μA
Reference voltage supply current	I <sub>R</sub>	AVRH	—	—	200	—	μA
	I <sub>RH</sub>	AVRH	Supply current when CPU stopped and A/D converter not in operation (V <sub>CC</sub> = AV <sub>CC</sub> = AVR <sub>H</sub> = 5.0 V)	—	—	5	μA
Offset between channels	—	AN0 to AN7	—	—	—	4	LSB

## 6. A/D Converter Glossary

Resolution: Analog changes that are identifiable with the A/D converter

Linearity error: The deviation of the straight line connecting the zero transition point ("00 0000 0000" ↔ "00 0000 0001") with the full-scale transition point ("11 1111 1110" ↔ "11 1111 1111") from actual conversion characteristics

Differential linearity error: The deviation of input voltage needed to change the output code by 1 LSB from the theoretical value

Total error: The total error is defined as a difference between the actual value and the theoretical value, which includes zero-transition error/full-scale transition error and linearity error.

www.DataSheet4U.com

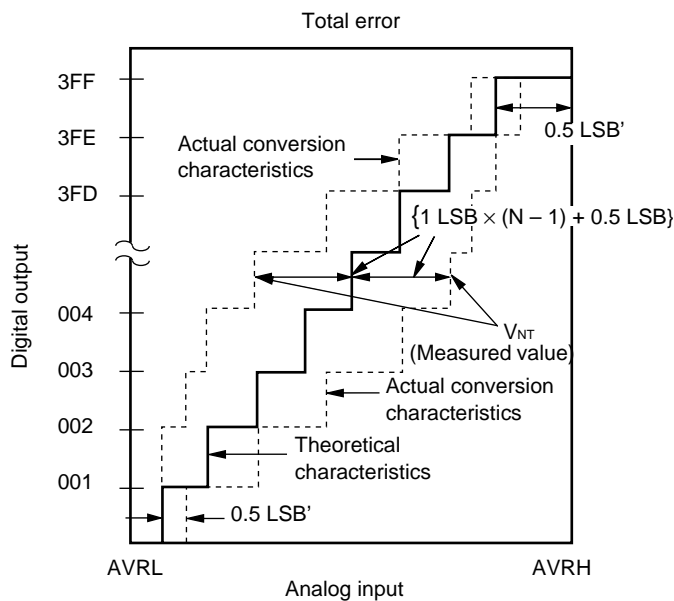

$$1 \text{ LSB}' = (\text{Theoretical value}) \frac{\text{AVRH} - \text{AVRL}}{1024} \text{ [V]}$$

$$\text{Total error for digital output } N = \frac{V_{NT} - \{1 \text{ LSB}' \times (N - 1) + 0.5 \text{ LSB}'\}}{1 \text{ LSB}'} \text{ [LSB]}$$

$$V_{0T}' (\text{Theoretical value}) = \text{AVRL} + 0.5 \text{ LSB}' \text{ [V]}$$

$V_{NT}$ : Voltage at a transition of digital output from (N - 1) to N

$$V_{FST}' (\text{Theoretical value}) = \text{AVRH} - 1.5 \text{ LSB}' \text{ [V]}$$

(Continued)

(Continued)

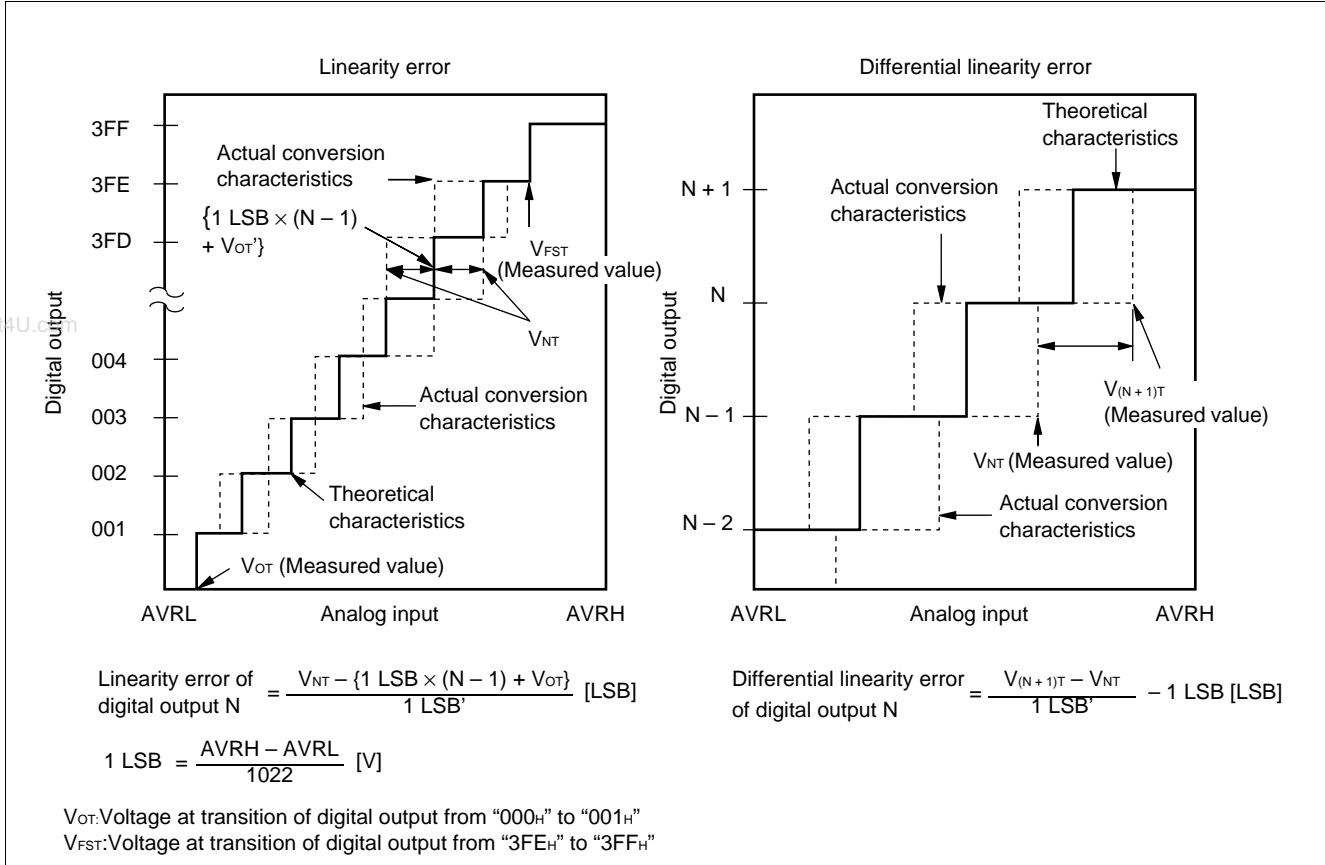

### 7. Notes on Using A/D Converter

Select the output impedance value for the external circuit of analog input according to the following conditions. Output impedance values of the external circuit of 7 kΩ or lower are recommended.

When capacitors are connected to external pins, the capacitance of several thousand times the internal capacitor value is recommended to minimize the effect of voltage distribution between the external capacitor and internal capacitor.

When the output impedance of the external circuit is too high, the sampling time for analog voltages may not be sufficient (sampling time = 3.75 μs @ machine clock of 16 MHz).

• **Block diagram of analog input circuit model**

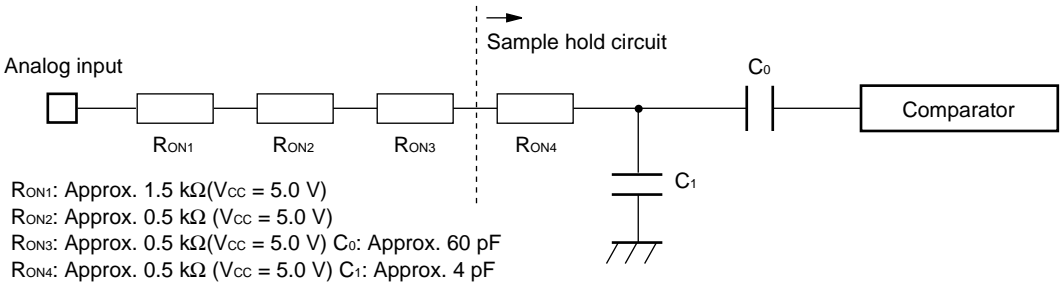

Note : Listed values must be considered as standards.

• **Error**

The smaller the  $|AVRH - AVRL|$ , the greater the error would become relatively.

# MB90670/675 Series

## EXAMPLE CHARACTERISTICS

(1) "H" Level Output Voltage

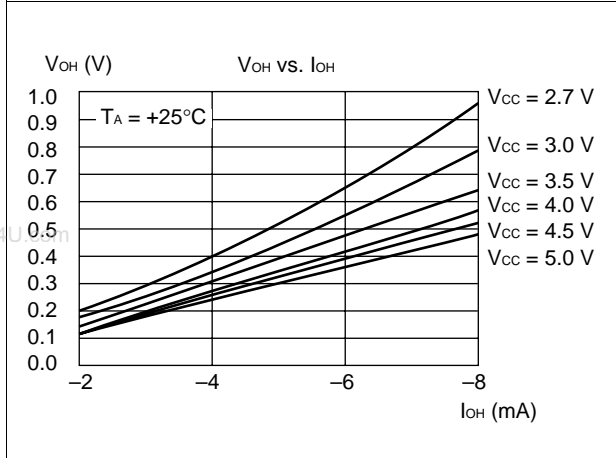

(2) "L" Level Output Voltage

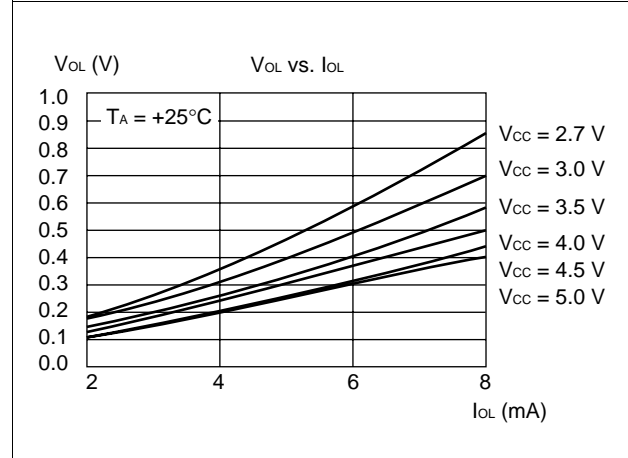

(3) "H" Level Input Voltage/"L" Level Input Voltage (CMOS Input)

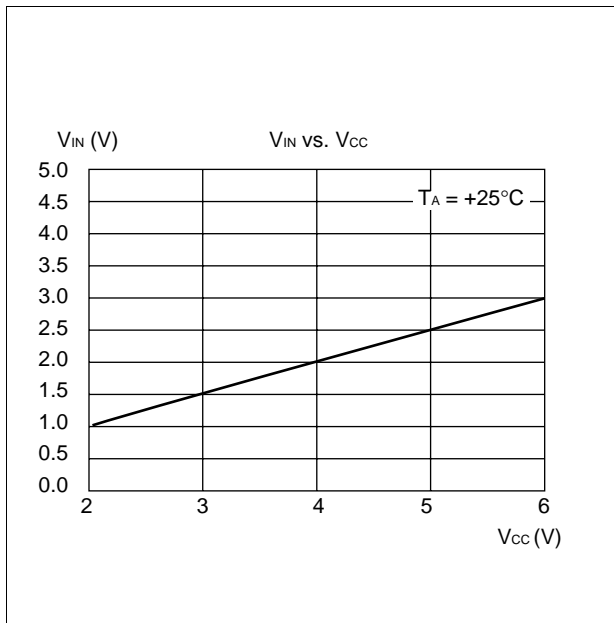

(4) "H" Level Input Voltage/"L" Level Input Voltage (Hysteresis Input)

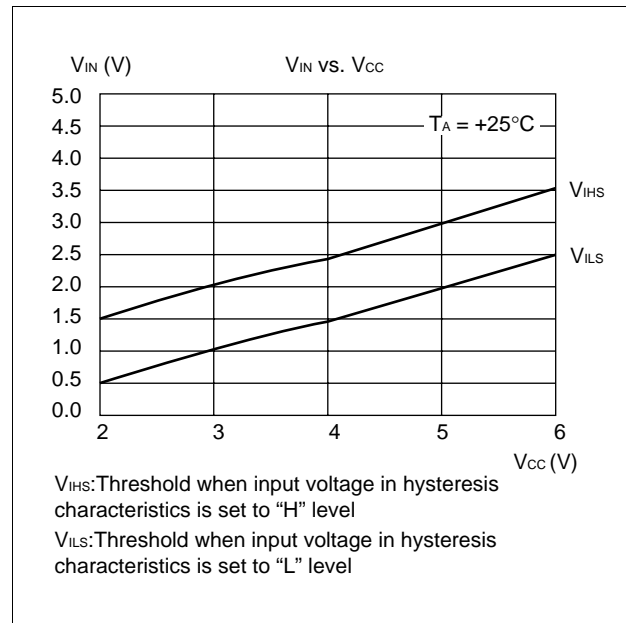

**(5) Power Supply Current ( $f_{CP}$  = Internal Operating Clock Frequency)**

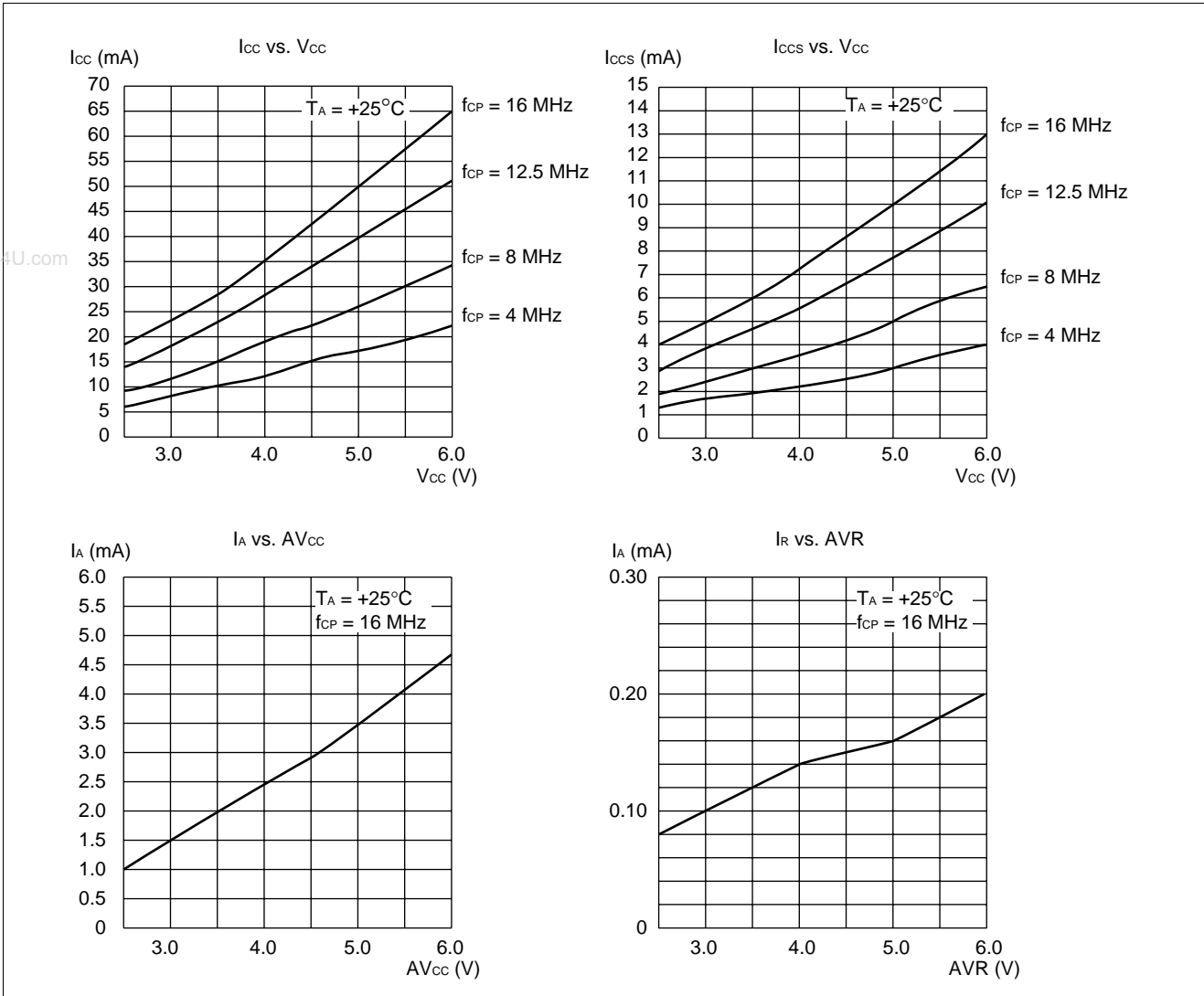

**(6) Pull-up Resistance**

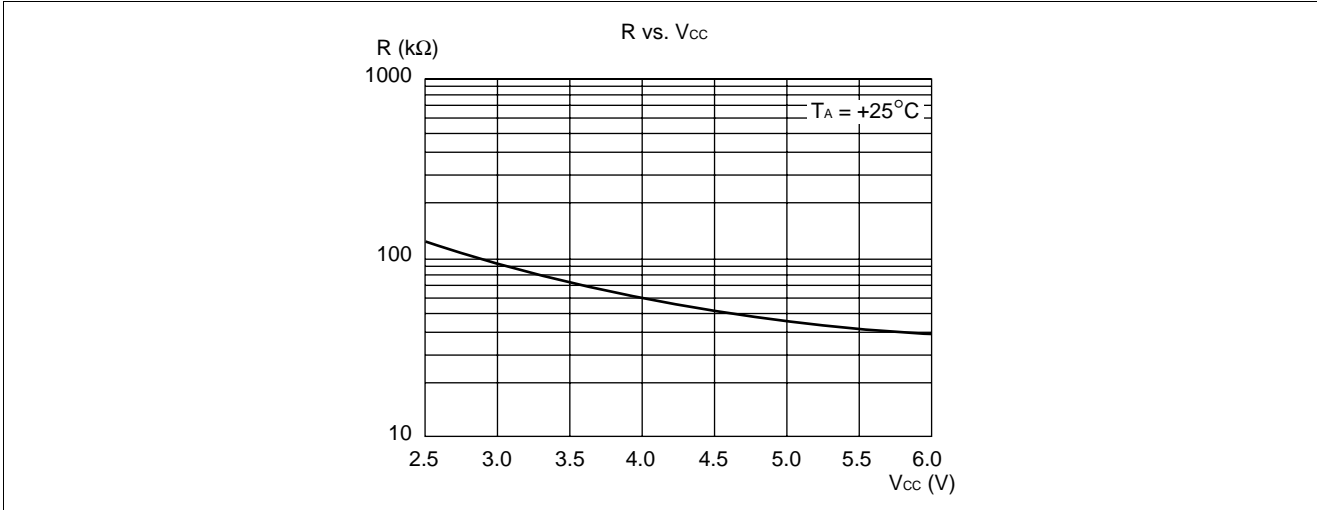

# MB90670/675 Series

## ■ MASK OPTIONS

### • MB90670 series

No.	Part number	MB90671 MB90672 MB90673	MB90P673	MB90V670
	Specifying procedure	Specify when ordering masking	Set with EPROM programmer	Setting not possible
1	Pull-up resistors P00 to P07, P10 to P17, P20 to P27, P30 to P37, P40 to P47, P60 to P67, P70 to P77, P80, $\overline{RST}$ , MD1, MD0	Specify by pin	Specify by pin	Without pull-up resistor
2	Pull-down resistors MD1, MD0	Specify by pin	Specify by pin	Without pull-up resistor

### • MB90675 series

No.	Part number	MB90676 MB90677 MB90678	MB90P678	MB90V670
	Specifying procedure	Specify when ordering masking	Set with EPROM programmer	Setting not possible
1	Pull-up resistors P00 to P07, P10 to P17, P20 to P27, P30 to P37, P40 to P47, P60 to P67, P70 to P77, P80 to P86, P90, P91, PA0 to PA7, PB0 to PB2, $\overline{RST}$ , MD1, MD0	Specify by pin	Specify by pin	Without pull-up resistor
2	Pull-down resistors MD1, MD0	Specify by pin	Specify by pin	Without pull-up resistor

Notes : • The pull-up register configured as a port pin is switched-off in the stop mode and during the hardware standby.

- In turning on power, option settings can not be made until clocks are supplied because 8 machine cycles are needed for option settings for the MB90P670/P675.

# MB90670/675 Series

## ■ ORDERING INFORMATION

Part number	Package	Remarks
MB90671PFV MB90672PFV MB90673PFV MB90T673PFV MB90P673PFV	80-pin Plastic LQFP (FPT-80P-M05)	
MB90671PF MB90672PF MB90673PF MB90T673PF MB90P673PF	80-pin Plastic QFP (FPT-80P-M06)	
MB90676PFV MB90677PFV MB90678PFV MB90T678PFV MB90P678PFV	100-pin Plastic LQFP (FPT-100P-M05)	
MB90676PF MB90677PF MB90678PF MB90T678PF MB90P678PF	100-pin Plastic QFP (FPT-100P-M06)	

# MB90670/675 Series

## PACKAGE DIMENSIONS

80-pin Plastic LQFP  
(FPT-80P-M05)

Note: pins width and pins thickness include plating thickness.

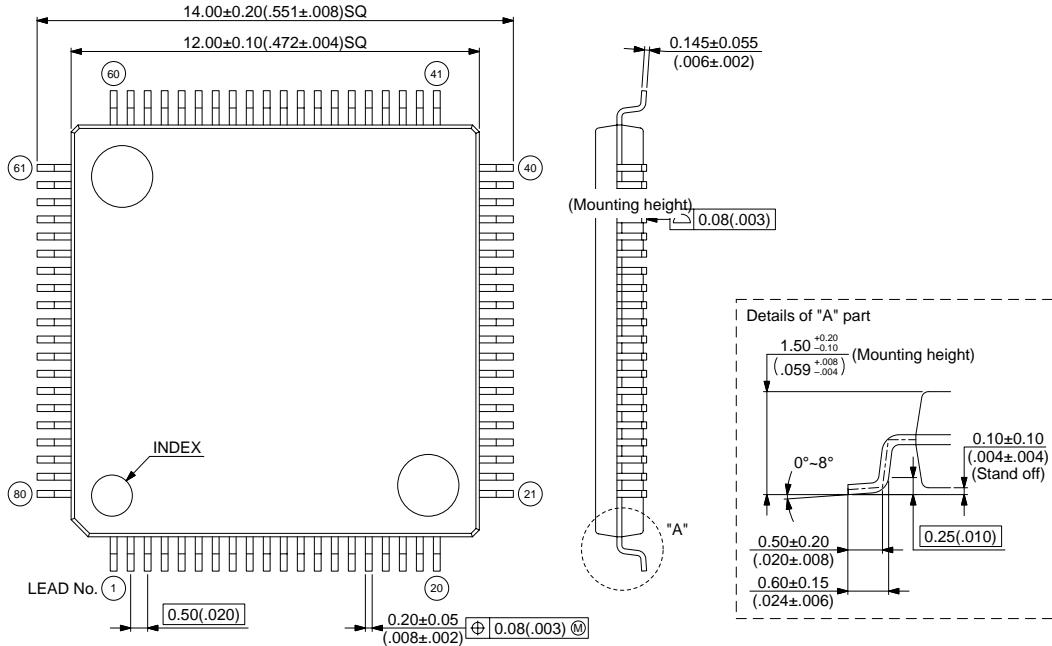

© 2000 FUJITSU LIMITED F80008S-c-3-7

Dimensions in mm (inches)

80-pin Plastic QFP  
(FPT-80P-M06)

Note: pins width and pins thickness include plating thickness.

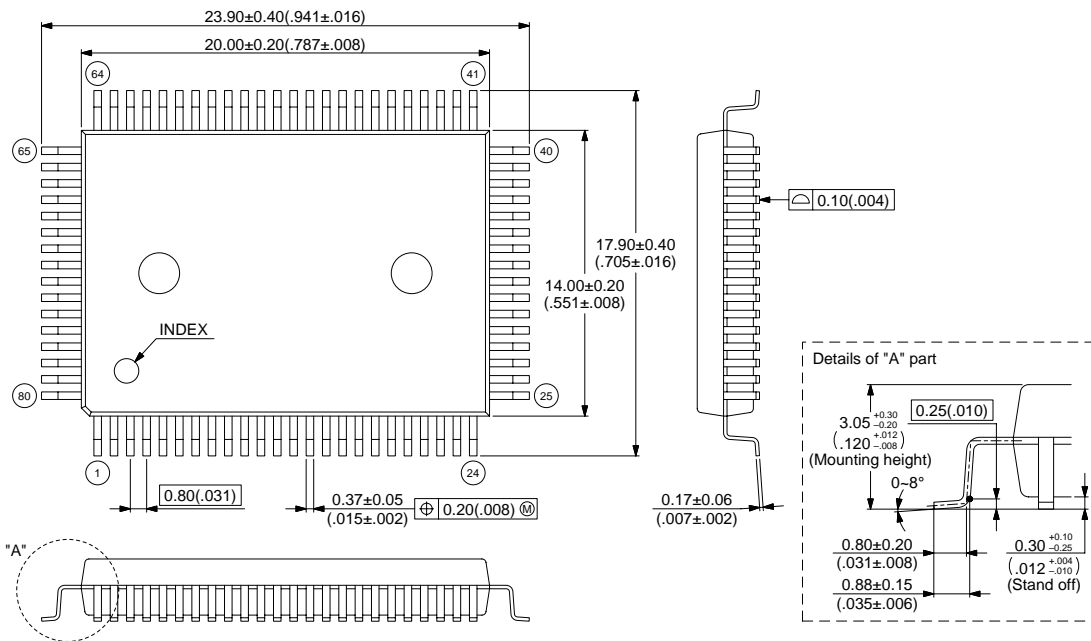

© 2001 FUJITSU LIMITED F80010S-c-4-4

Dimensions in mm (inches)



# MB90670/675 Series

(Continued)

## 100-pin Plastic LQFP (FPT-100P-M05)

Note: pins width and pins thickness include plating thickness.

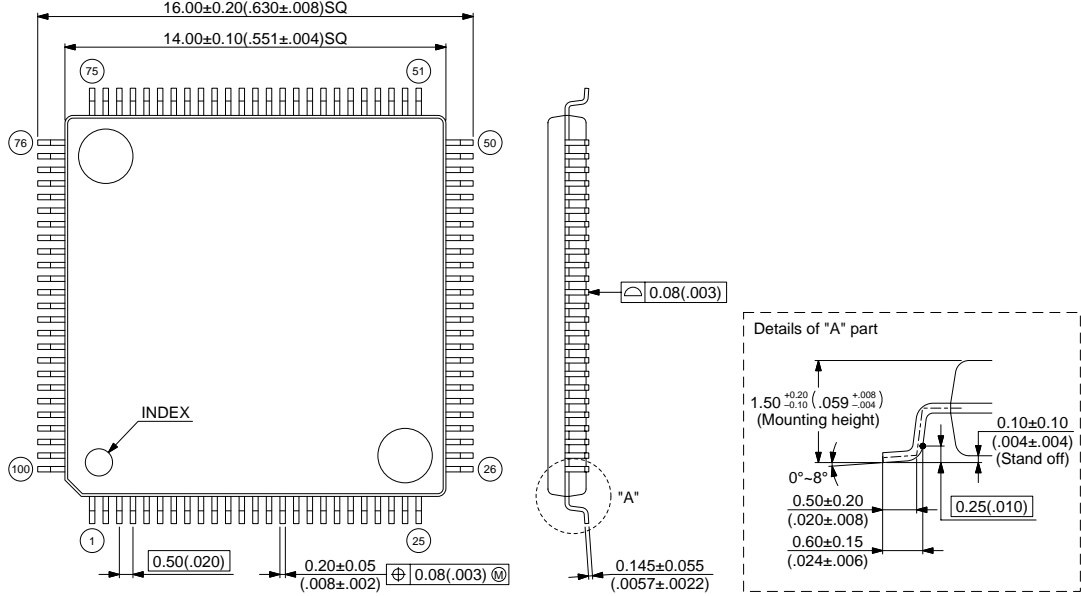

© 2000 FUJITSU LIMITED F100007S-3c-5

Dimensions in mm (inches)

## 100-pin Plastic QFP (FPT-100P-M06)

Note: pins width and pins thickness include plating thickness.

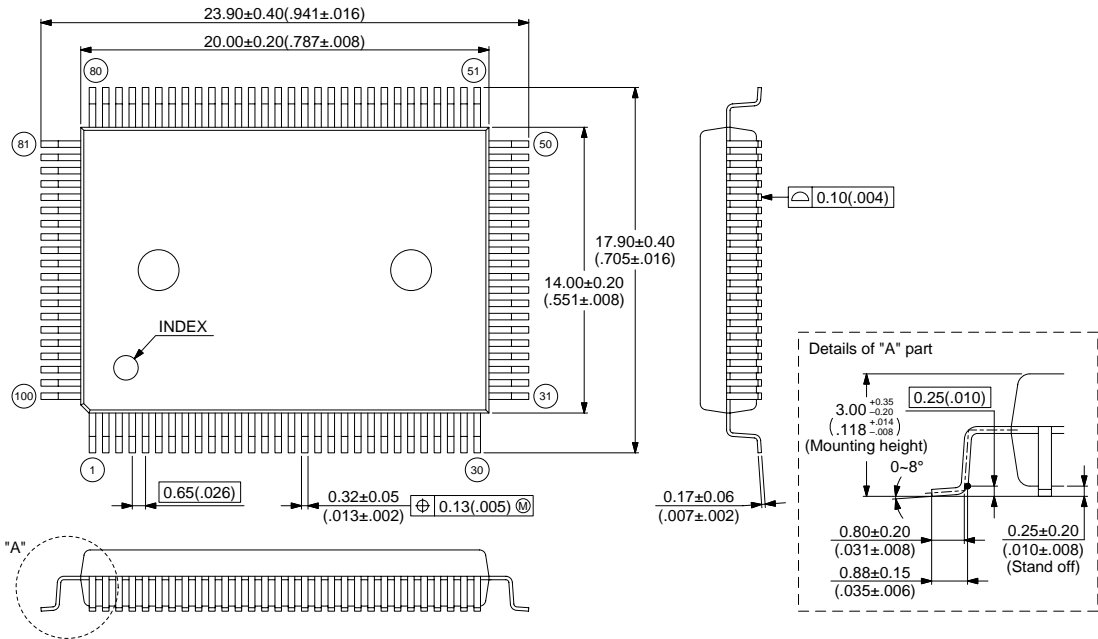

© 2001 FUJITSU LIMITED F100008S-c-4-4

Dimensions in mm (inches)

# MB90670/675 Series

## FUJITSU LIMITED

All Rights Reserved.

The contents of this document are subject to change without notice. Customers are advised to consult with FUJITSU sales representatives before ordering.

The information and circuit diagrams in this document are presented as examples of semiconductor device applications, and are not intended to be incorporated in devices for actual use. Also, FUJITSU is unable to assume responsibility for infringement of any patent rights or other rights of third parties arising from the use of this information or circuit diagrams.

The products described in this document are designed, developed and manufactured as contemplated for general use, including without limitation, ordinary industrial use, general office use, personal use, and household use, but are not designed, developed and manufactured as contemplated (1) for use accompanying fatal risks or dangers that, unless extremely high safety is secured, could have a serious effect to the public, and could lead directly to death, personal injury, severe physical damage or other loss (i.e., nuclear reaction control in nuclear facility, aircraft flight control, air traffic control, mass transport control, medical life support system, missile launch control in weapon system), or (2) for use requiring extremely high reliability (i.e., submersible repeater and artificial satellite).

Please note that Fujitsu will not be liable against you and/or any third party for any claims or damages arising in connection with above-mentioned uses of the products.

Any semiconductor devices have an inherent chance of failure. You must protect against injury, damage or loss from such failures by incorporating safety design measures into your facility and equipment such as redundancy, fire protection, and prevention of over-current levels and other abnormal operating conditions.

If any products described in this document represent goods or technologies subject to certain restrictions on export under the Foreign Exchange and Foreign Trade Law of Japan, the prior authorization by Japanese government will be required for export of those products from Japan.

F0111  
© FUJITSU LIMITED Printed in Japan