

PRODUCT SPECIFICATION FOR LCM MODULE

MODULE NO. : ET12864CV3
REVERSION : A
TYPE : COB

Customer Approval:

--

PREPARED BY		DATE	
CHECKED BY		DATE	
APPROVED BY		DATE	

CONTENTS

1. PHYSICAL DATA
2. EXTERNAL DIMENSIONS
3. ABSOLUTE MAXIMUM RATINGS
4. OPERATING PRINCIPLES & METHODS
5. ELECTRICAL CHARACTERISTICS
6. ELECTRO-OPTICAL CHARACTERISTICS
7. CAUTIONS FOR USING LCD MODULES
8. USING LCD MODULES

1. PHYSICAL DATA

Dots Format : 128*64Dots.

EAST ET TECHNOLOGY CO., LTD.

Tel: 86-755-83427955 61332400

E-mail: east@eastet.com

Fax: 86-755-83421997

Http://www.eastet.com

LCD mode : STN, Yellow Green
 Viewing direction : 6 o'clock
 Driving condition : 1/64 Duty , 1/9 Bias .
 Power supply voltage : +5V
 Backlight Type : Yellow Green LED Backlight,
 Operating temperature : 0~50°C
 Storage temperature : -10~60°C
 Module size (L×W×H) : Refer to the outline drawing .
 Viewing area (L×W) : Refer to the outline drawing .
 Dot size (W×H) : Refer to the outline drawing .
 Dot pitch (W×H) : Refer to the outline drawing .

2. EXTERNAL DIMENSIONS

Figure 1. External Dimensions

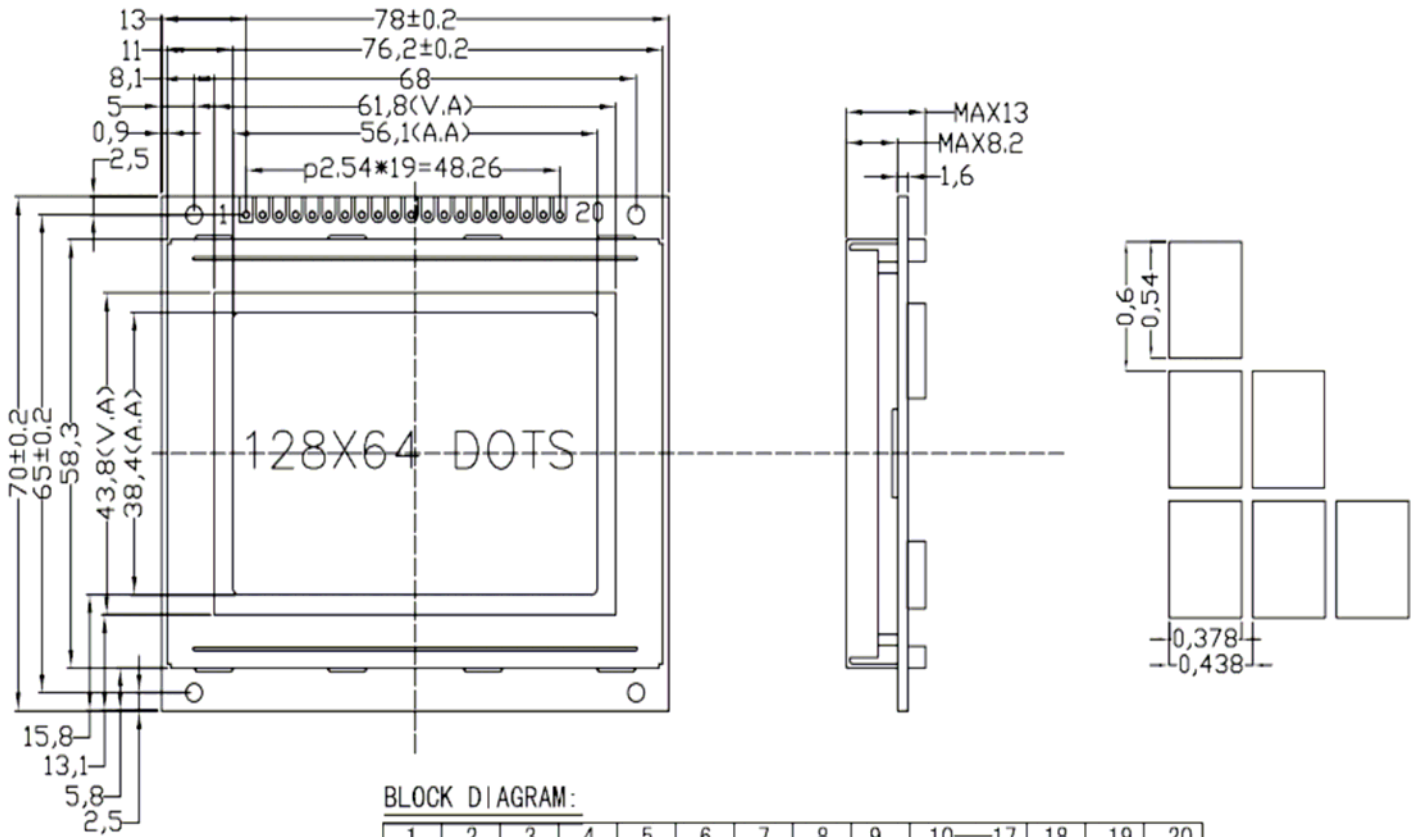

DISPLAY TYPE: STN/POSITIVE
 VIEWING DIRECTION: 6:00
 POLARIZER MODE: TRANSMISSIVE
 DRIVING METHOD: 1/64DUTY 1/9BIAS
 OPERATING VOLTAGE: 5.0V
 OPERATING TEMPERATURE: -0° ~ 50°C
 STORAGE TEMPERATURE: -10°~60°C
 CONNCTOR: ZEBRA

3. ABSOLUTE MAXIMUM RATINGS (Ta = 25°C)

Table 1. Absolute Maximum Ratings

Parameter	Symbol	Min	Max	Unit
Supply voltage for logic	Vdd	-0.3	7.0	V
Supply current	Idd	-	10	mA
Supply voltage for LED	Vled		5.0	V
Supply current for LED	Iled		100	mA
Operating temperature	Top	0	50	°C
Storage temperature	Tst	-10	60	°C

*Note: Based on Vss=0V.

4. OPERATING PRINCIPLES & METHODS

Table 2. Interface Pin Connections

Pin No.	Symbol	Level	Description
1	FG	Power supply	Ground of frame
2	VSS	Power supply	Ground
3	VDD	Power supply	Power supply +.
4	Vo	Power supply	Operation voltage of LCD
5	/WR	H/L	Write
6	/RD	H/L	Read
7	/CE	H/L	Chip select signal for IC
8	C/D	H/L	H: DB<0:7> Display RAM Data, L: DB<0:7> Instruction Data
9.	/RST	H/L	Reset signal
10~17	DB0~DB7	H/L	Data Bus
18	FS		Font select
19	LEDA	5V	Side light anode
20	LEDK	0V	Side light cathode

Figure 2. Block Diagram

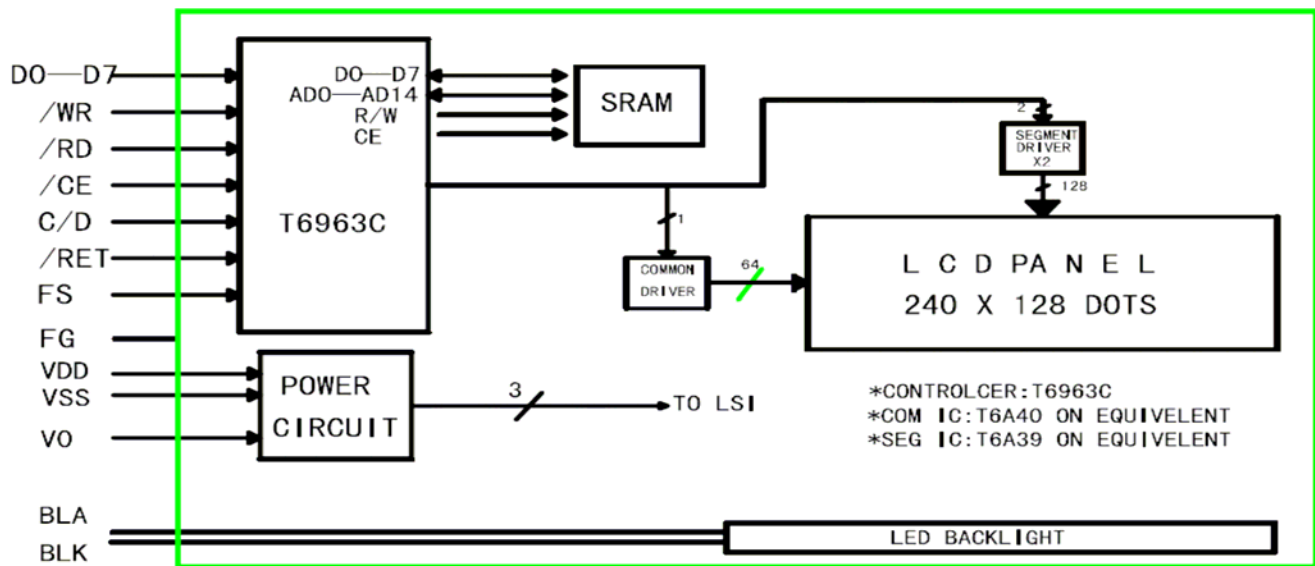

Instruction table

Command	Code	D1	D2	Function
REGISTERS SETTING	00100001 00100010 00100100	X address Data Low address	Y address 00H High address	Set Cursor Pointer Set Offset Register Set Address Pointer
SET CONTROL WORD	01000000 01000001 01000010 01000011	Low address Columns Low address Columns	High address 00H High address 00H	Set Text Home Address Set Text Area Set Graphic Home Address Set Graphic Area
MODE SET	1000X000 1000X001 1000X011 1000X100 10000XXX 10001XXX	— — — — — —	— — — — — —	OR mode EXOR mode AND mode Text Attribute mode Internal CG ROM mode External CG RAM mode
DISPLAY MODE	10010000 1001XX10 1001XX11 100101XX 100110XX 100111XX	— — — — — —	— — — — — —	Display off Cursor on, blink off Cursor on, blink on Text on, graphic off Text off, graphic on Text on, graphic on
CURSOR PATTERN SELECT	10100000 10100001 10100010 10100011 10100100 10100101 10100110 10100111	— — — — — — — —	— — — — — — — —	1-line cursor 2-line cursor 3-line cursor 4-line cursor 5-line cursor 6-line cursor 7-line cursor 8-line cursor
DATA AUTO READ / WRITE	10110000 10110001 10110010	— — —	— — —	Set Data Auto Write Set Data Auto Read Auto Reset
DATA READ / WRITE	11000000 11000001 11000010 11000011 11000100 11000101	Data — Data — Data —	— — — — — —	Data Write and Increment ADP Data Read and Increment ADP Data Write and Decrement ADP Data Read and Decrement ADP Data Write and Nonvariable ADP Data Read and Nonvariable ADP
SCREEN PEEK	11100000	—	—	Screen Peek
SCREEN COPY	11101000			Screen Copy

COMMAND	CODE	D1	D2	FUNCTION
BIT SET / RESET	11110XXX	—	—	Bit Reset
	11111XXX	—	—	Bit Set
	1111X000	—	—	Bit 0 (LSB)
	1111X001	—	—	Bit 1
	1111X010	—	—	Bit 2
	1111X011	—	—	Bit 3
	1111X100	—	—	Bit 4
	1111X101	—	—	Bit 5
	1111X110	—	—	Bit 6
	1111X111	—	—	Bit 7 (MSB)

See the “T6963C” data sheet of *TOSHIBA* to get more detail.

5. ELECTRICAL CHARACTERISTICS (Based on Ta = -20 to 70 deg. C, Vss = 0 V)

DC Characteristics

Table 3. DC Characteristics

Item	Symbol	Min	Type	Max	Unit	Applicable terminal	Test condition
Operating voltage	V _{DD}	4.5	5.0	5.5	V	-	--
Supply current	I _{DD}	-		10	mA	V _{DD}	During display
VOP	V _{DD-VO}	19	20.0	21		V _{DD} , V _{VO}	25°C
Supply backlight voltage	V _{led}	4.5	5.0	5.5 V	V	LEDA, LEDK	Turn on LED
Input backlight current	I _{led}		-	100	mA	LEDA, LEDK	Turn on LED
Output voltage	V _{OUT}	-	-10	-	V	V _{OUT}	V _{DD} =5V
Input voltage	V _{IL}	0	-	0.3V _{DD}	V	RS, R/W, CS1, CS2, E, DB0~DB7	-
	V _{IH}	0.7V _{DD}	-		V		

6. ELECTRO-OPTICAL CHARACTERISTICS (V_{DD}=5.0V, Ta = 25 °C)

Table 5. Electro-Optical Characteristics

Item	Symbol	Condition	Min	Type	Max	Unit	Remarks	Note
Contrast ratio	Cr	---	2	3	---	---	---	1
Viewing angle range	θ	Cr ≥ 2	35	---	---	deg	∅ = 90°	2
			35	---	---	deg	∅ = 270°	2
			50	---	---	deg	∅ = 0°	2
			33	---	---	deg	∅ = 180°	2

Figure 6. Definition of contrast ratio 'Cr'. & viewing angle range 'θ'.

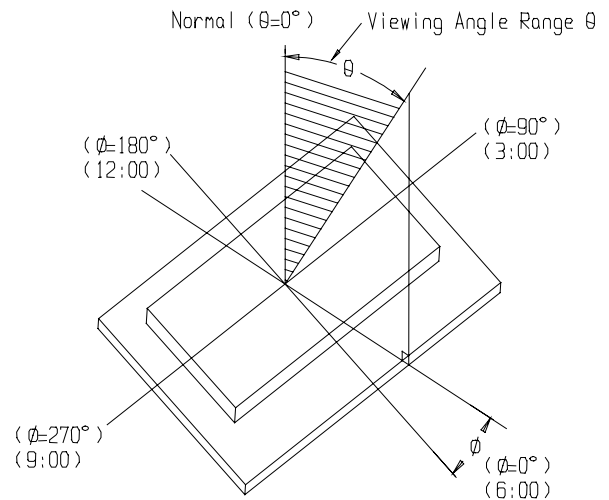
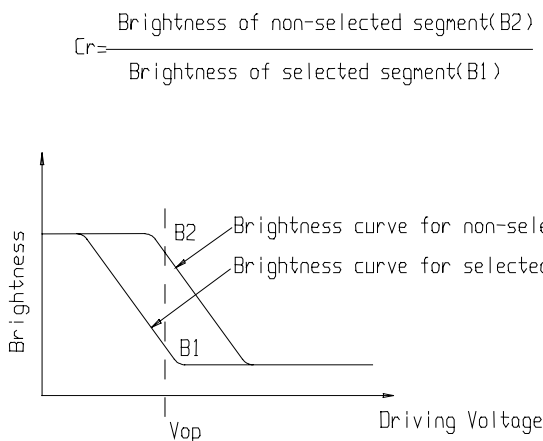

Note1: Definition of contrast ratio Cr .

Note2: Definition of viewing angle range 'θ'.

7. PRECAUTIONS FOR USING LCD MODULES

Handling Precautions

- (1) The display panel is made of glass. Do not subject it to a mechanical shock by dropping it or impact.
- (2) If the display panel is damaged and the liquid crystal substance leaks out, be sure not to get any in your mouth. If the substance contacts your skin or clothes, wash it off using soap and water.
- (3) Do not apply excessive force to the display surface or the adjoining areas since this may cause the color tone to vary.
- (4) The polarizer covering the display surface of the LCD module is soft and easily scratched. Handle this polarizer carefully.
- (5) If the display surface becomes contaminated, breathe on the surface and gently wipe it with a soft dry cloth. If it is heavily contaminated, moisten cloth with one of the following solvents :
 - Isopropyl alcohol
 - Ethyl alcohol
- (6) Solvents other than those above-mentioned may damage the polarizer. Especially, do not use the following.
 - Water
 - Ketone
 - Aromatic solvents
- (7) Exercise care to minimize corrosion of the electrode. Corrosion of the electrodes is accelerated by water droplets, moisture condensation or a current flow in a high-humidity environment.
- (8) Install the LCD Module by using the mounting holes. When mounting the LCD module make sure it is free of twisting, warping and distortion. In particular, do not forcibly pull or bend the I/O cable or the backlight cable.
- (9) Do not attempt to disassemble or process the LCD module.
- (10) NC terminal should be open. Do not connect anything.
- (11) If the logic circuit power is off, do not apply the input signals.
- (12) To prevent destruction of the elements by static electricity, be careful to maintain an optimum work environment.
 - Be sure to ground the body when handling the LCD modules.
 - Tools required for assembling, such as soldering irons, must be properly grounded.
 - To reduce the amount of static electricity generated, do not conduct assembling and other work under dry conditions.

- The LCD module is coated with a film to protect the display surface. Exercise care when peeling off this protective film since static electricity may be generated.

Storage Precautions

When storing the LCD modules, avoid exposure to direct sunlight or to the light of fluorescent lamps. Keep the modules in bags (avoid high temperature / high humidity and low temperatures below 0°C). Whenever possible, the LCD modules should be stored in the same conditions in which they were shipped from our company.

Others

Liquid crystals solidify under low temperature (below the storage temperature range) leading to defective orientation or the generation of air bubbles (black or white). Air bubbles may also be generated if the module is subject to a low temperature.

If the LCD modules have been operating for a long time showing the same display patterns, the display patterns may remain on the screen as ghost images and a slight contrast irregularity may also appear. A normal operating status can be regained by suspending use for some time. It should be noted that this phenomenon does not adversely affect performance reliability.

To minimize the performance degradation of the LCD modules resulting from destruction caused by static electricity etc., exercise care to avoid holding the following sections when handling the modules.

- Exposed area of the printed circuit board.
- Terminal electrode sections.

8. USING LCD MODULES

Liquid Crystal Display Modules

LCD is composed of glass and polarizer. Pay attention to the following items when handling.

(1) Please keep the temperature within specified range for use and storage. Polarization degradation, bubble generation or polarizer peel-off may occur with high temperature and high humidity.

(2) Do not touch, push or rub the exposed polarizers with anything harder than an HB pencil lead (glass, tweezers, etc.).

(3) N-hexane is recommended for cleaning the adhesives used to attach front/rear polarizers and reflectors made of organic substances which will be damaged by chemicals such as acetone, toluene, ethanol and isopropylalcohol.

(4) When the display surface becomes dusty, wipe gently with absorbent cotton or other soft material like chamois soaked in petroleum benzine. Do not scrub hard to avoid damaging the display surface.

(5) Wipe off saliva or water drops immediately, contact with water over a long period of time may cause deformation or color fading.

(6) Avoid contacting oil and fats.

(7) Condensation on the surface and contact with terminals due to cold will damage, stain or dirty the polarizers. After products are tested at low temperature they must be warmed up in a container before coming in contact with room temperature air.

(8) Do not put or attach anything on the display area to avoid leaving marks on.

(9) Do not touch the display with bare hands. This will stain the display area and degrade insulation between terminals (some cosmetics are determined to the polarizers).

(10) As glass is fragile. It tends to become or chipped during handling especially on the edges. Please avoid dropping or jarring.

Installing LCD Modules

The hole in the printed circuit board is used to fix LCM as shown in the picture below. Attend to the following items when installing the LCM.

- (1) Cover the surface with a transparent protective plate to protect the polarizer and LC cell.

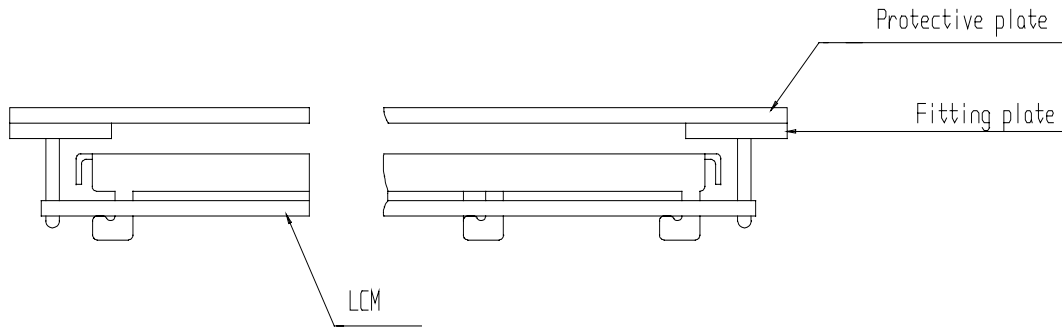

(2) When assembling the LCM into other equipment, the spacer to the bit between the LCM and the fitting plate should have enough height to avoid causing stress to the module surface, refer to the individual specifications for measurements. The measurement tolerance should be ± 0.1 mm.

Precaution for Handling LCD Modules

Since LCM has been assembled and adjusted with a high degree of precision, avoid applying excessive shocks to the module or making any alterations or modifications to it.

- (1) Do not alter, modify or change the shape of the tab on the metal frame.
- (2) Do not make extra holes on the printed circuit board, modify its shape or change the positions of components to be attached.
- (3) Do not damage or modify the pattern writing on the printed circuit board.
- (4) Absolutely do not modify the zebra rubber strip (conductive rubber) or heat seal connector.
- (5) Except for soldering the interface, do not make any alterations or modifications with a soldering iron.
- (6) Do not drop, bend or twist LCM.
- (7) In order to avoid the cracking of the FPC, you should to pay attention to the area of FPC (R50mm) where the FPC was bent .the edge of coverlay ; the area of surface of Ni-Au plating, the area of soldering land, the area of through hole.

Electro-Static Discharge Control

Since this module uses a CMOS LSI, the same careful attention should be paid to electrostatic discharge as for an ordinary CMOS IC.

- (1) Make certain that you are grounded when handing LCM.
- (2) Before remove LCM from its packing case or incorporating it into a set, be sure the module and your body have the same electric potential.
- (3) When soldering the terminal of LCM, make certain the AC power source for the soldering iron does not leak.
- (4) When using an electric screwdriver to attach LCM, the screwdriver should be of ground potentiality to minimize as much as possible any transmission of electromagnetic waves produced sparks coming from the commutator of the motor.
- (5) As far as possible make the electric potential of your work clothes and that of the work bench the ground potential.
- (6) To reduce the generation of static electricity be careful that the air in the work is not too dried. A relative humidity of 50%-60% is recommended.

Precaution for soldering to the LCM

- (1) Observe the following when soldering lead wire, connector cable and etc. to the LCM.
 - Soldering iron temperature : $260^{\circ}\text{C} \pm 10^{\circ}\text{C}$.
 - Soldering time : 3-4 sec.
 - Solder : eutectic solder.

If soldering flux is used, be sure to remove any remaining flux after finishing to soldering operation. (This does not apply in the case of a non-halogen type of flux.) It is recommended that you protect the LCD surface with a cover during soldering to prevent any damage dur to flux spatters.

- (2) When soldering the electroluminescent panel and PC board, the panel and board should not be detached more than three times. This maximum number is determined by the temperature and time conditions mentioned above, though there may be some variance depending on the temperature of the soldering iron.

(3) When remove the electoluminescent panel from the PC board, be sure the solder has completely melted, the soldered pad on the PC board could be damaged.

(4) Soldering iron is not allowed to touch the surface of FPC's cover film directly.

Precautions for Operation

(1) Viewing angle varies with the change of liquid crystal driving voltage (VO). Adjust VO to show the best contrast.

(2) Driving the LCD in the voltage above the limit shortens its life.

(3) Response time is greatly delayed at temperature below the operating temperature range. However, this does not mean the LCD will be out of the order. It will recover when it returns to the specified temperature range.

(4) If the display area is pushed hard during operation, the display will become abnormal. However, it will return to normal if it is turned off and then back on.

(5) Condensation on terminals can cause an electrochemical reaction disrupting the terminal circuit. Therefore, it must be used under the relative condition of 40°C , 50% RH.

(6) When turning the power on, input each signal after the positive/negative voltage becomes stable.

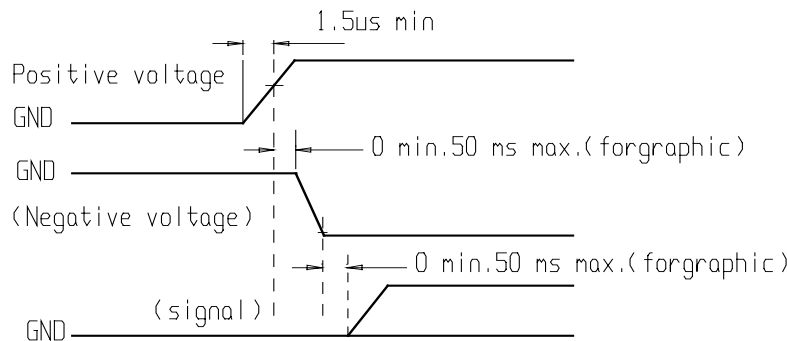

Storage

When storing LCDs as spares for some years, the following precaution are necessary.

(1) Store them in a sealed polyethylene bag. If properly sealed, there is no need for dessicant.

(2) Store them in a dark place. Do not expose to sunlight or fluorescent light, keep the temperature between 0°C and 35°C.

(3) The polarizer surface should not come in contact with any other objects. (We advise you to store them in the container in which they were shipped.)

(4) Environmental conditions :

- Do not leave them for more than 160hrs. at 70°C.
- Should not be left for more than 48hrs. at -20°C.

Safety

(1) It is recommended to crush damaged or unnecessary LCDs into pieces and wash them off with solvents such as acetone and ethanol, which should later be burned.

(2) If any liquid leaks out of a damaged glass cell and comes in contact with the hands, wash off thoroughly with soap and water.

Limited Warranty

Unless agreed between EAST and customer, EAST will replace or repair any of its LCD modules which are found to be functionally defective when inspected in accordance with EAST LCD acceptance standards (copies available upon request) for a period of one year from date of shipments. Cosmetic/visual defects must be returned to EAST within 90 days of shipment. Confirmation of such date shall be based on freight documents. The warranty liability of EAST limited to repair and/or replacement on the terms set forth above. EAST will not be responsible for any subsequent or consequential events.

Return LCM under warranty

No warranty can be granted if the precautions stated above have been disregarded. The typical examples of violations are :

- Broken LCD glass.
- PCB eyelet's damaged or modified.
- PCB conductors damaged.
- Circuit modified in any way, including addition of components.
- PCB tampered with by grinding, engraving or painting varnish.
- soldering to or modifying the bezel in any manner.

Module repairs will be invoiced to the customer upon mutual agreement. Modules must be returned with sufficient description of the failures or defects. Any connectors or cable installed by the customer must be removed completely without damaging the PCB's eyelet, conductors and terminals.