

Customer Name	Standard Specification	FUJITSU MEDIA DEVICES LIMITED	
System	TV-IF	DATE	Jun. 30, 2003
FMD Part Number	FAR-F4SE-43M750-A006	Version_1.1	

Table 1. Electrical specifications

Ta=25 °C (45 °C)						
Item	Condition (MHz)	FMD Proposal			Unit	Remarks
		Min.	Typ.	Max.		
Insertion Loss	44.060(44.000)	13.3	14.8	16.3	dB	
Relative Attenuation	39.810(39.750)	---	-41	-37	dB	
	40.310(40.250)	---	-14	-9	dB	
	40.810(40.750)	-4.2	-3.0	-1.8	dB	
	41.280(41.220)	-1.1	-0.1	0.9	dB	
	43.810(43.750)	---	0	---	dB	Ref.
	46.340(46.280)	-1.1	-0.1	0.9	dB	
	46.810(46.750)	-4.2	-3.0	-1.8	dB	
	47.310(47.250)	---	-14	-9	dB	
	47.810(47.750)	---	-41	-35	dB	
	Lower sidelobe	35.060 – 39.060 (35.000 – 39.000)	---	-46	-40	dB
39.060 – 39.810 (39.000 – 39.750)		---	-40	-35	dB	
Upper sidelobe	47.810 – 50.060 (47.750 – 50.000)	---	-40	-35	dB	
	50.060 – 55.060 (50.000 – 55.000)	---	-43	-40	dB	
Amplitude Ripple (p-p)	41.280 – 46.340 (41.220 – 46.280)	-	0.3	0.7	dB	
Group delay Ripple (p-p)	41.280 – 46.340 (41.220 – 46.280)	-	26	60	ns	
Capacitance at 1MHz	Cin	-	15.5	-	pF	
	Cout	-	3.6	-	pF	
Temperature drift	Cf	-	-72	-	ppm/°C	

Customer Name	Standard Specification	FUJITSU MEDIA DEVICES LIMITED	
System	TV-IF	DATE	Jun. 30, 2003
FMD Part Number	FAR-F4SE-43M750-A006	Version_1.1	

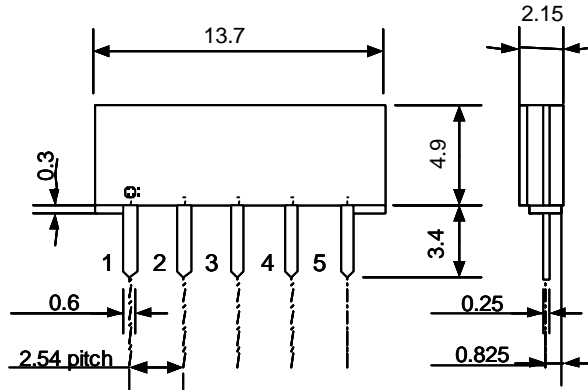

Pin No. 1	INPUT
2	INPUT
3	GROUND
4	OUTPUT
5	OUTPUT

Figure 1. Package Dimension

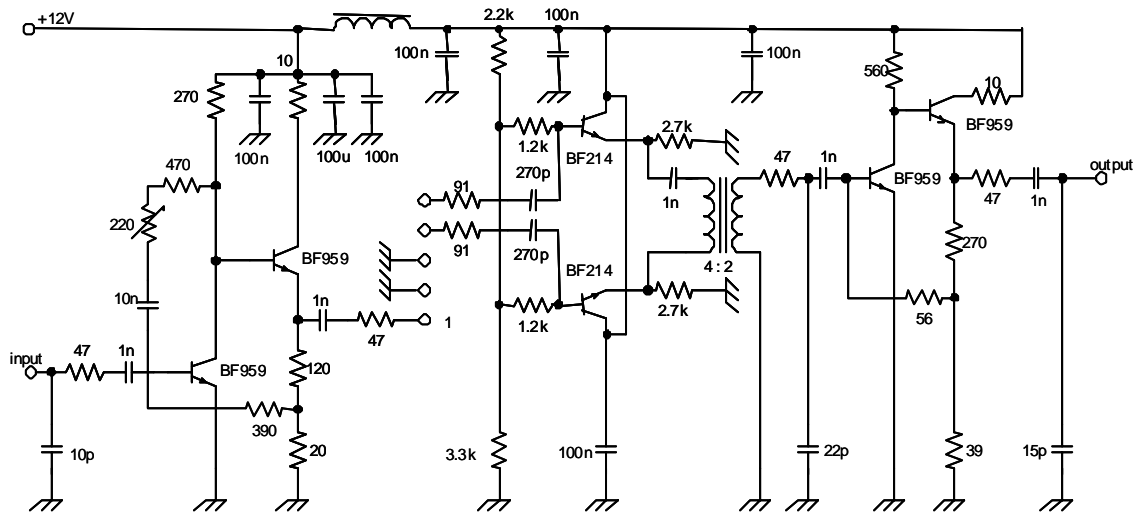

Figure 2. Measurement Circuit

Customer Name	Standard Specification	FUJITSU MEDIA DEVICES LIMITED	
System	TV-IF	DATE	Jun. 30, 2003
FMD Part Number	FAR-F4SE-43M750-A006	Version_1.1	

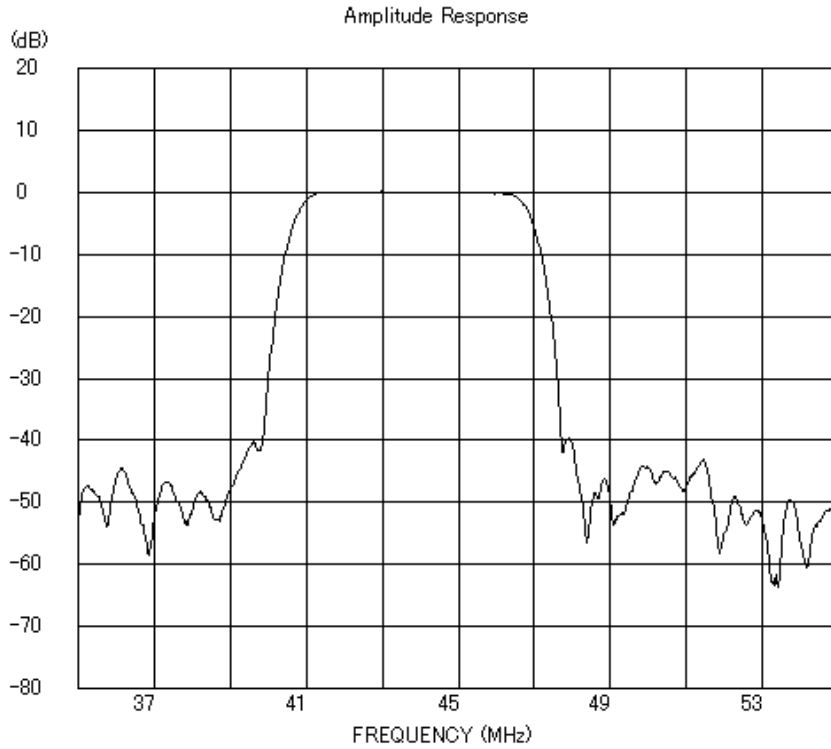

Figure 3. Full-band characteristics

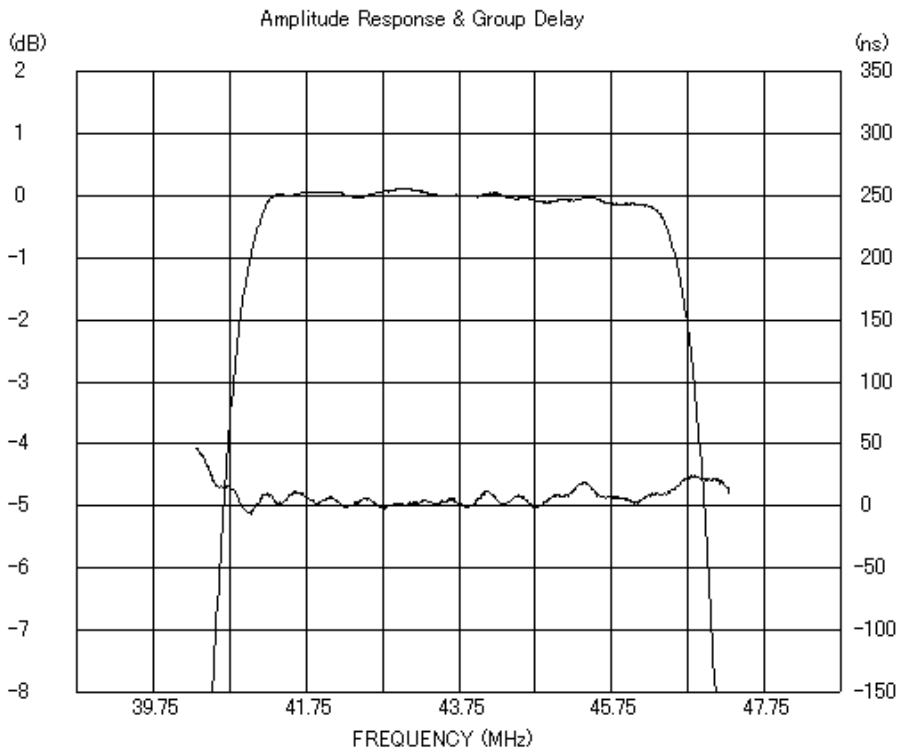

Figure 4. Pass-band and group delay characteristics