

Silicon Tuning Diode

- High Q hyperband tuning diode
- Low series inductance
- Designed for low tuning voltage operation
- For VCO's in mobile communications equipment

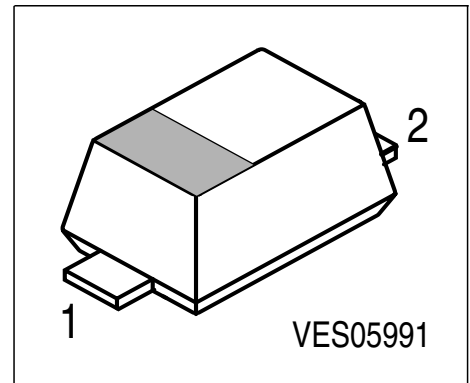

Type	Marking	Pin Configuration		Package
BBY 52-02W	K	1 = C	2 = A	SCD-80

Maximum Ratings

Parameter	Symbol	Value	Unit
Diode reverse voltage	V_R	7	V
Forward current	I_F	20	mA
Operating temperature range	T_{op}	-55 ... 150	°C
Storage temperature	T_{stg}	-55 ... 150	

Electrical Characteristics at $T_A = 25^\circ\text{C}$, unless otherwise specified.

Parameter	Symbol	Values			Unit
		min.	typ.	max.	
DC characteristics					
Reverse current $V_R = 6\text{ V}$	I_R	-	-	10	nA
Reverse current $V_R = 6\text{ V}, T_A = 150^\circ\text{C}$	I_R	-	-	100	
AC characteristics					
Diode capacitance $V_R = 1\text{ V}, f = 1\text{ MHz}$ $V_R = 2\text{ V}, f = 1\text{ MHz}$ $V_R = 3\text{ V}, f = 1\text{ MHz}$ $V_R = 4\text{ V}, f = 1\text{ MHz}$	C_T	1.4 0.95 0.9 0.85	1.85 1.5 1.35 1.15	2.2 2 1.75 1.45	pF
Capacitance ratio $V_R = 1\text{ V}, V_R = 4\text{ V}, f = 1\text{ MHz}$	C_{T1}/C_{T4}	1.1	1.6	2.1	-
Series resistance $V_R = 1\text{ V}, f = 1\text{ GHz}$	r_s	-	0.9	1.7	Ω
Case capacitance $f = 1\text{ MHz}$	C_C	-	0.09	-	pF
Series inductance	L_s	-	0.6	-	nH

Diode capacitance $C_T = f(V_R)$

$f = 1\text{MHz}$

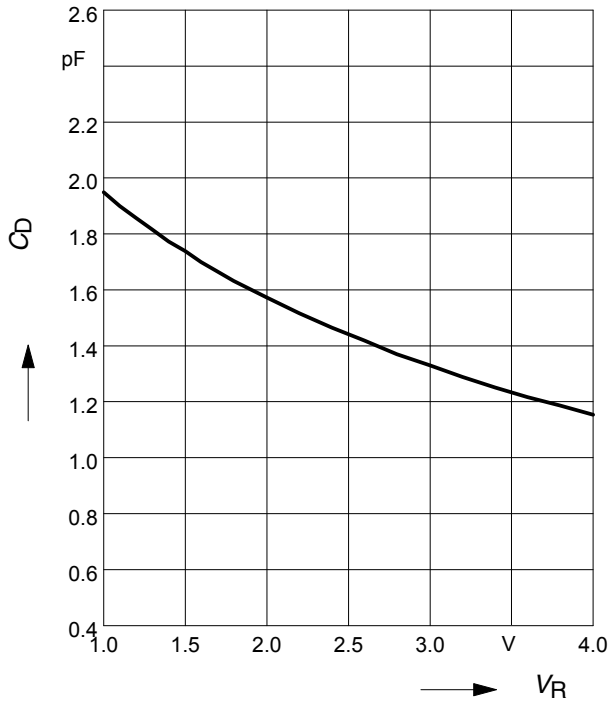

Reverse current $I_R = f(V_R)$

$T_A = 25\text{ }^\circ\text{C}$

