

Features

- Single power supply can operate at 2.4V through 6V.
- Current output can drive 8 ohm speaker with a transistor, Vout can drive buzzer directly.
- The voice content is stored for 7-12 seconds for SI121 (13-24 for SI241/241B) including mute and is single section /phrase and single trigger.
- Automatic power down.
- A phrase is composed of repetitive sections.
- Interrupt function (INTP) stops the audio output at once.
- An LED function with 3Hz flash is provided to tell the audio status.
- A STOP pulse comes out when audio signal is finished.
- CDS input interface with 10ms debounce is provided for trigger pin, REP pin and INTP pin.
- Repeat pin was provided to keep audio output repeating.
- Built-in power on play function and is programmable.
- Programmable option for either Retrigger or not.
- Programmable option for either Level or Edge trigger type.
- Programmable option for either Holdable or Unholdable output type.
- Programmable option for repeat times up to 8 times.
- Programmable option for either LED display or STOP pulse on LED/STP pin.
- SI121 can be programmed by MSM9159, MSM9156, MSM9140 & MSM9139.
- SI241/241B can be programmed by MSM9159, MSM9140.

Block Diagram

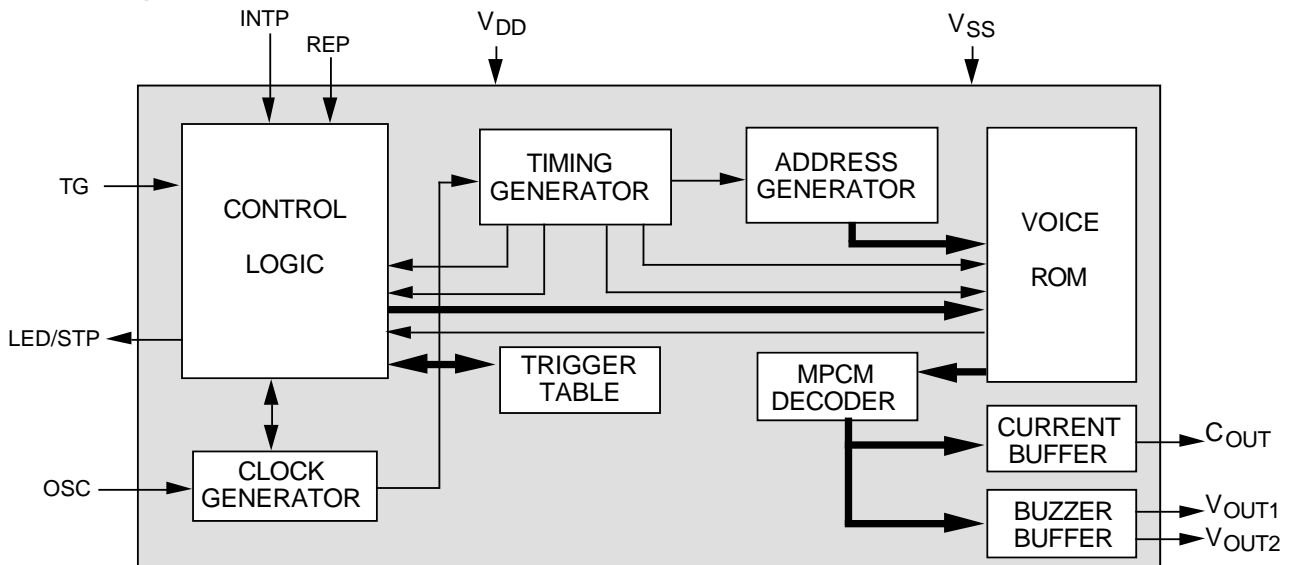

Description

The MSSI121/241/241B is an one time programmable CMOS VLSI ASIC that can memorize voice for 7-12 / 13-24 seconds using 6-bit MOSEL qualified coding method (MPCM). Most of the necessary circuit are built in like oscillator, ROM, DAC and interface logic. Versatile functions can be performed with minimum external components. Customer voice data will be edited and built in by MOSEL writer in an instant time base.

Pad Description

Pad No.	Signal Name	I/O	Function
1	VDD	Power	Positive power supply
2	OSC	I	Oscillator Resistor input
3	CLK	I	Clock for programming
4	C OUT	O	Audio signal current output (for speaker)
5	INTP	I	Interrupt input, internal pull low, high active
6	REP	I	Repeat pin, high active
7	LED/STP	O	LED signal output / One shot stop signal output
8	VOUT1	O	Audio signal voltage output (for buzzer)
9	VOUT2	O	Audio signal voltage output (for buzzer)
10	TG	I	Trigger input, internal pull low, high active
11	VSS	Power	Negative power supply

DC Characteristics

Symbol	Parameter	Min.	Typ.	Max.	Unit	Condition
I _{SB}	Supply Current	Stand by	—	—	1	V _{DD} = 4.5V, I/O Open depend on programmed data
I _{OP}		Operating	—	—	500	
V _{IH}	Input Voltage TG, INTP, REP	4	4.5	5	V	V _{DD} = 4.5V
V _{IL}		-0.3	0	+0.3		
I _{OH}	O/P Current V _{OUT1} , V _{OUT2}	Drive	—	-12	mA	V _{DD} = 4.5V, V _{O/P} = 0V
I _{OL}		Sink	—	12		
I _{OH}	O/P Current V _{OUT1} , V _{OUT2}	Drive	—	-11	mA	V _{DD} = 4.5V, V _{O/P} = 0V
I _{OL}		Sink	—	11		
I _{CO}	Output Current (C _{OUT})	—	4	—	mA	V _{DD} = 3.0V, Full scale
		—	6	—		V _{DD} = 4.5V, Full scale
I _{OH}	Output Current STP	—	-5	—	mA	V _{DD} = 4.5V, V _{O/P} = 0V
I _{OL}		—	+5	—		V _{DD} = 4.5V, V _{O/P} = 4.5V
I _{LED}	Output Current LED	—	12	—	mA	V _{DD} = 4.5V, V _{DD} -V _{O/P} = 2V
		—	7.5	—		
I _{LK}	Input Leakage current	0	—	10	μA	V _{DD} = 4.5V
ΔF/F	Frequency Stability	—	—	° 5	%	$\frac{F_{osc}(4.5V) - F_{osc}(4V)}{F_{osc}(4.5V)}$
ΔF/F	Fosc Variation	—	—	° 10	%	V _{DD} = 4.5V, R _{osc} = 1.2MΩ
R1	Oscillation Resistor	—	1100	—	KΩ	V _{DD} = 3.0V, S.R. = 6KHz
		—	770	—		V _{DD} = 3.0V, S.R. = 8KHz
		—	1200	—		V _{DD} = 4.5V, S.R. = 6KHz
		—	850	—		V _{DD} = 4.5V, S.R. = 8KHz
		—	910	—		V _{DD} = 3.0V, S.R. = 6KHz
		—	660	—		V _{DD} = 3.0V, S.R. = 8KHz
		—	970	—		V _{DD} = 4.5V, S.R. = 6KHz
		—	700	—		V _{DD} = 4.5V, S.R. = 8KHz

Absolute Maximum Rating

Symbol	Rating	Unit
$V_{DD} \sim V_{SS}$	-0.5 ~ +7.0	V
V_{IN}	$V_{SS} - 0.3 < V_{IN} < V_{DD} + 0.3$	V
V_{OUT}	$V_{SS} < V_{OUT} < V_{DD}$	V
T (Operating)	-10 ~ +60	°C
T (Storage)	-55 ~ +125	°C

Pin Configurations

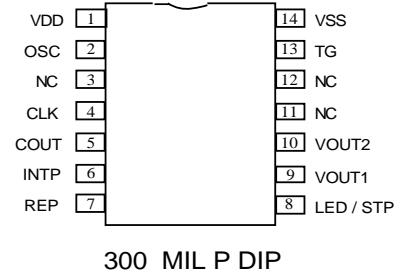

AC Characteristics

Timing		Min	Typ	Max	Unit
T_T	Trigger pulse width	—	10	—	ms
T_{STOP}	Stop pulse	—	20	—	ms

Timing Diagram

I. Edge/Unholdable / Irretrigger Option

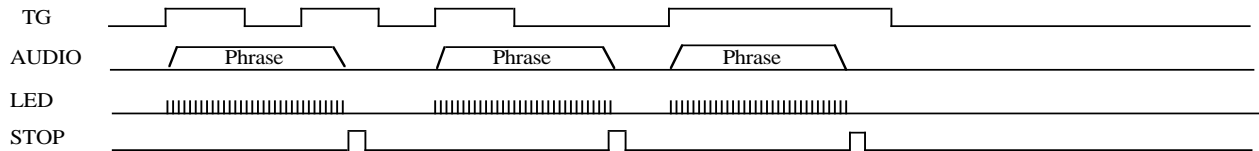

II. Level/Unholdable / Irretrigger Option

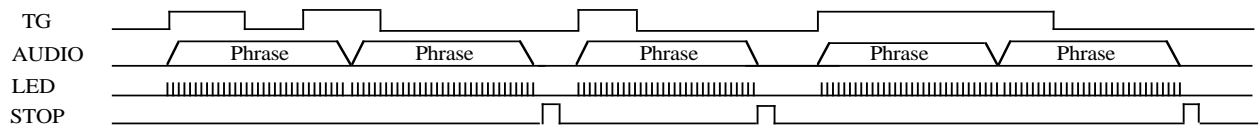

III. Edge/Holdable Trigger Mask

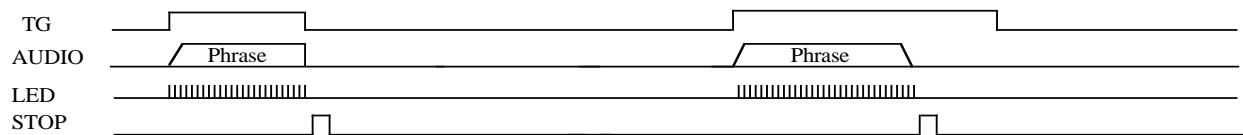

IV. Level/Holdable Trigger Option

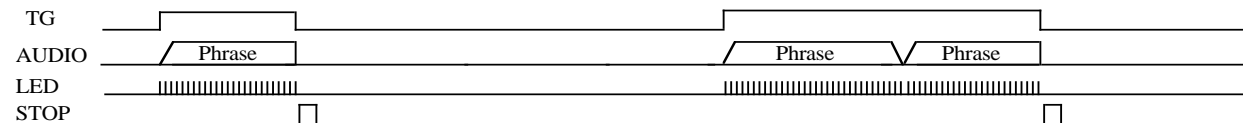

V. Interrupt Pin Function (LED Or Stop)

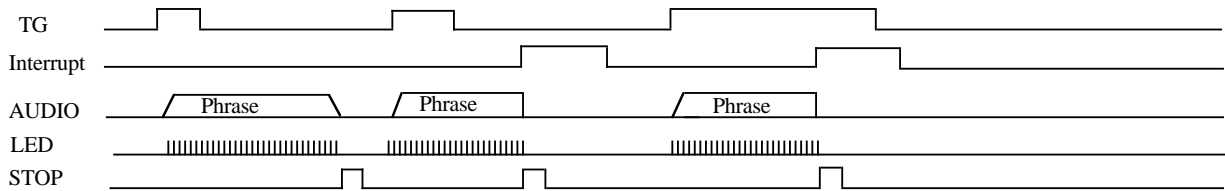

VI. Repeat Pin Function

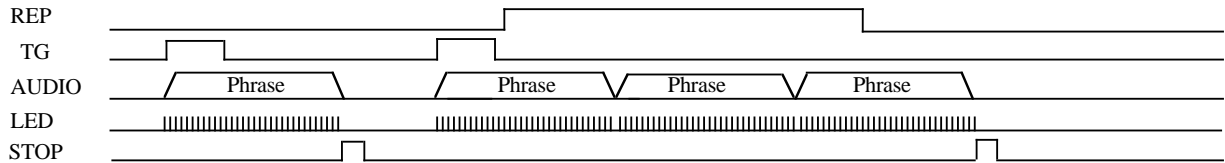

VII. DEBOUNCE TIME

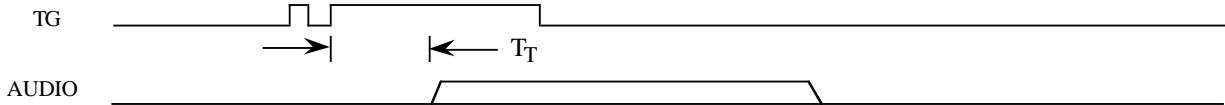

Application Circuit

1. Typical Application

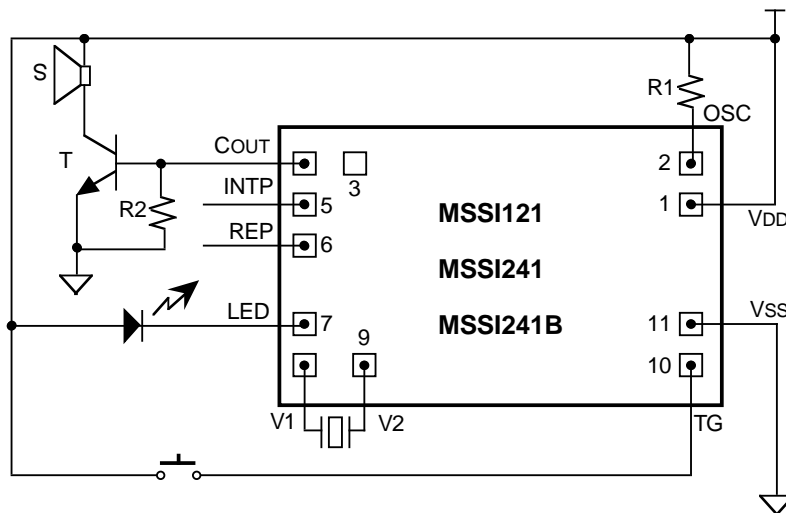

Pad No.	Designation	I121		I241		I241B	
		X	Y	X	Y	X	Y
1	V _{DD}	-953.3	1415.3	-935.3	2170.7	-795	1960.7
2	OSC	-1182.3	1413.9	-1182.3	2169.3	-1005	1959.6
3	CLK	-1408.3	-1153.4	-1408.3	1908.4	-1199.6	-1729.2
4	COUT	-1404.8	-142.5	-1386.4	-2180	-1175.9	-1965.2
5	INTP	-752.7	-1417.2	-750.6	-2170	-632.1	-1959.2
6	REP	-224.9	-1415	-224.9	-2170	-191.2	-1959.2
7	LED/STP	1089.7	-1417.2	1091.8	-2170	928	-1959.2
8	VOUT1	1408.3	-1327.9	1408.3	-2082.8	1199.6	-1887.7
9	VOUT2	1418	-1117.5	1418	-1872.6	1207.8	-1703.9
10	TG	1329	1423.6	1329	2170	1132.2	1965.3
11	VSS	1092	1440.1	1092	2195.7	928.2	1982

DIE SIZE: 3210um X 3290um (I121)
 3210um X 4800um (I241)
 2750um X 4340um (I241B)
Pad size = 125um X 125 um
Note: Substrate is V_{SS}

2. Cascade Application (To get longer than 12/24 seconds) you have to avoid these two chips play at the same time, it might danger the speaker

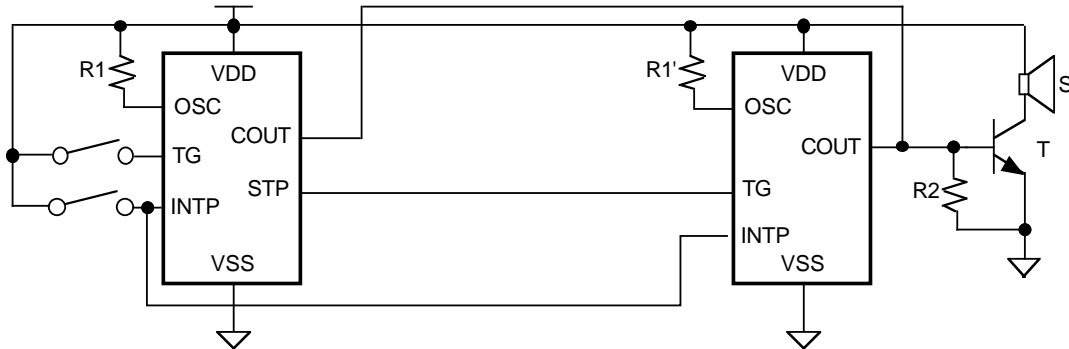

3. CDS Application

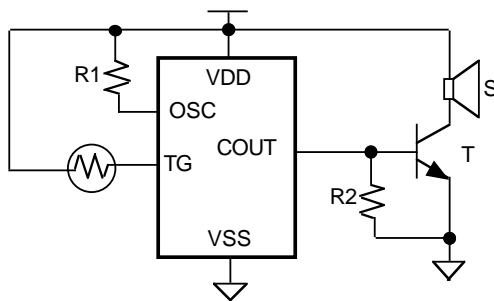

4. Equivalent to Level type trigger under "Edge option"

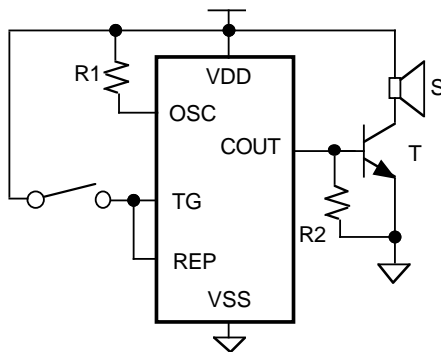

- Note:
1. R1 = 1.2 M Ω , T(transistor) = $\beta > 130$, S(speaker) = 1/4 w, 8 Ω ; all typical.
 2. R2 = 470 Ω (typical) to bypass extra current into base to get rid of waveform saturation on collector .
 3. Piezo buzzer resonant frequency is around 1K Hz.
 4. Input switch could be replaced by CDS.
 5. VOUT1,VOUT2 are tristate during stand by .
 6. If using MSM9159 writer, use its new version MSM9159B to program MSSI121/241/241B chips. Do not use the old version MSM9159 writer. The difference between two version of writer should refer to its data sheet (PID 330B).
 7. Power on play function plays only one time regardless the number to repeat.