

SI-8000JD Series

Surface-Mount, Separate Excitation Switching Type

■Features

- Surface-mount package (TO263-5)
- Output current: 1.5 A
- High efficiency: 77 to 86%
- Requires only 4 external components
- Phase correction and output voltage adjustment performed internally
- Choke coil size can be reduced through the employment of high frequency (125 kHz) design
- Built-in foldback overcurrent protection, thermal protection circuit
- Output ON/OFF possible (OFF state current consumption: 200 μ A max)
- Soft start possible via ON/OFF pin

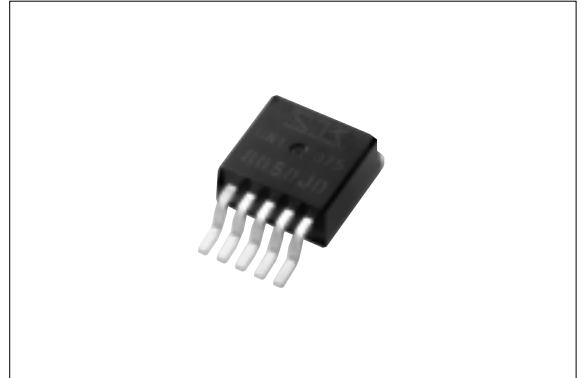

■Applications

- Power supplies for telecommunication equipment
- Onboard local power supplies, etc.

■Lineup

Part Number	SI-8033JD	SI-8050JD	SI-8090JD
V _o (V)	3.3	5.0	9.0
I _o (A)	1.5		

■Absolute Maximum Ratings

Parameter	Symbol	Ratings	Unit	Conditions
DC Input Voltage	V _{IN}	43	V	
Output Current	I _o	1.5	A	
Power Dissipation*	P _D	3	W	Glass-epoxy board mounting 40 × 40 mm (copper area 100%)
Junction Temperature	T _j	+125	°C	
Storage Temperature	T _{stg}	-40 to +125	°C	
Thermal Resistance (Junction to Case)	R _{th(j-c)}	3	°C/W	
Thermal Resistance (Junction to Ambient Air)	R _{th(j-a)}	33.3	°C/W	Glass-epoxy board mounting 40 × 40 mm (copper area 100%)

*: Limited by thermal protection circuit

■Recommended Operating Conditions

Parameter	Symbol	Ratings			Unit	Conditions
		SI-8033JD	SI-8050JD	SI-8090JD		
DC Input Voltage Range	V _{IN1}	5.3 to 6.3	7 to 8	11 to 12	V	I _o =0 to 1A
	V _{IN2}	6.3 to 40	8 to 40	12 to 40		I _o =0 to 1.5A
DC Output Current Range*	I _o	0 to 1.5			A	V _{IN} ≥V _o +3V
Operating Junction Temperature Range	T _{jop}	-30 to +125			°C	
Operating Temperature Range*	T _{op}	-30 to +125			°C	

*: Limited by Ta–P_D characteristics

Electrical Characteristics

(Ta=25°C)

Parameter	Symbol	Ratings									Unit
		SI-8033JD			SI-8050JD			SI-8090JD			
		min.	typ.	max.	min.	typ.	max.	min.	typ.	max.	
Output Voltage	Vo	3.234	3.30	3.366	4.90	5.00	5.10	8.82	9.00	9.18	V
	Conditions	VIN=15V, Io=0.5A			VIN=20V, Io=0.5A			VIN=21V, Io=0.5A			
Efficiency	η		77			82			86		%
	Conditions	VIN=15V, Io=0.5A			VIN=20V, Io=0.5A			VIN=21V, Io=0.5A			
Switching Frequency	f		125			125			125		kHz
	Conditions	VIN=15V, Io=0.5A			VIN=20V, Io=0.5A			VIN=21V, Io=0.5A			
Line Regulation	ΔV _{OLINE}		25	80		40	100		50	120	mV
	Conditions	VIN=8 to 30V, Io=0.5A			VIN=10 to 30V, Io=0.5A			VIN=15 to 30V, Io=0.5A			
Load Regulation	ΔV _{OLOAD}		10	30		10	40		10	40	mV
	Conditions	VIN=15V, Io=0.2 to 0.8A			VIN=20V, Io=0.2 to 0.8A			VIN=21V, Io=0.2 to 0.8A			
Temperature Coefficient of Output Voltage	ΔVo/ΔTa		±0.5			±0.5			±1.0		mV/°C
Overcurrent Protection Starting Current	IS1	1.6			1.6			1.6			A
ON/OFF* Pin	Low Level Voltage	VSSL		0.5		0.5			0.5		V
	Low-State Output Current	ISSL		100		100			100		μA
Quiescent Circuit Current	Iq		7			7			7		mA
	Conditions	VIN=15V, Io=0A			VIN=20V, Io=0A			VIN=21V, Io=0A			
	Iq(OFF)			200			200			200	μA
	Conditions	VIN=15V, VON/OFF=0.3V			VIN=20V, VON/OFF=0.3V			VIN=21V, VON/OFF=0.3V			

*: Pin 5 is the ON/OFF pin. Connecting a capacitor to this pin enables a soft start at power-on. By using this pin, the output can also be turned on or off. Driving a transistor with an open collector can perform switching of the potential of the ON/OFF pin. When using both the soft-start and ON/OFF functions together, the discharge current from C3 flows to the ON/OFF control transistor, so ensure that this current is limited for protection. The ON/OFF pin is pulled up to the power supply in the IC, so no external voltage can be applied. If this pin is not used, leave it open.

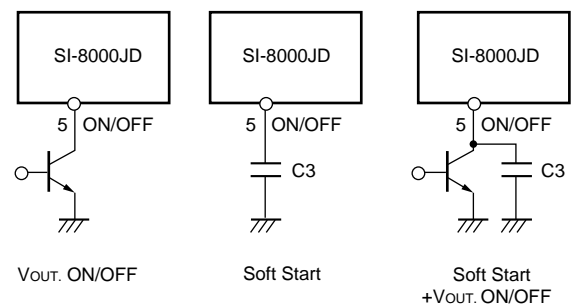

External Dimensions

(Unit : mm)

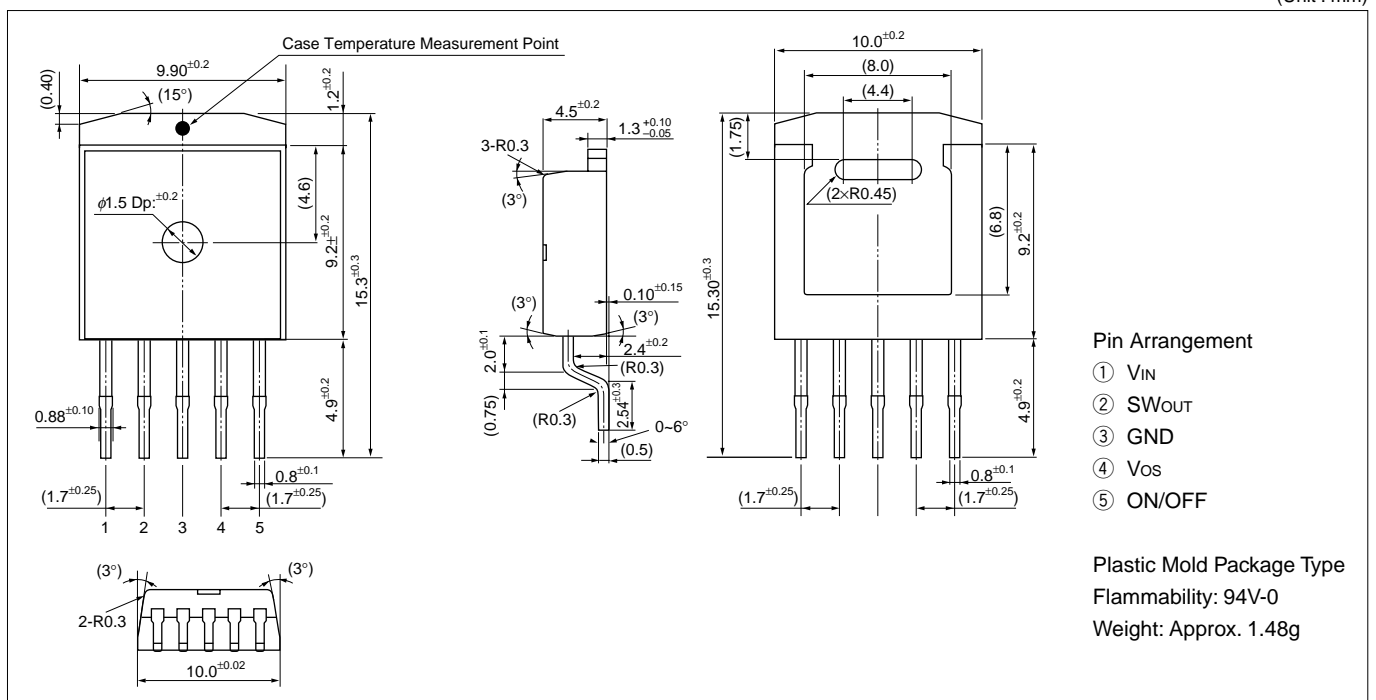

■Block Diagram

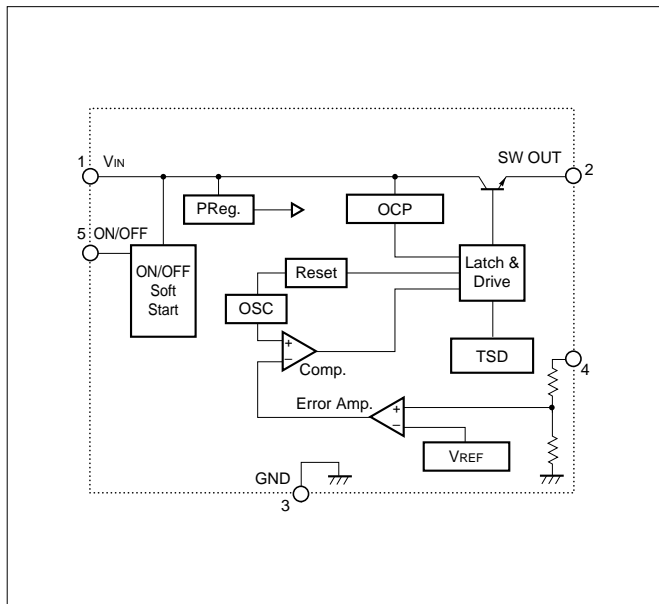

■Standard External Circuit

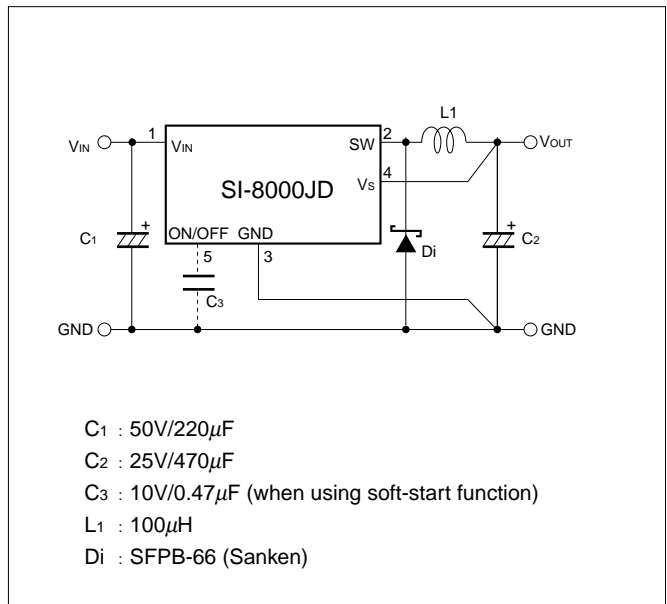

■Example of Pattern on PC Board

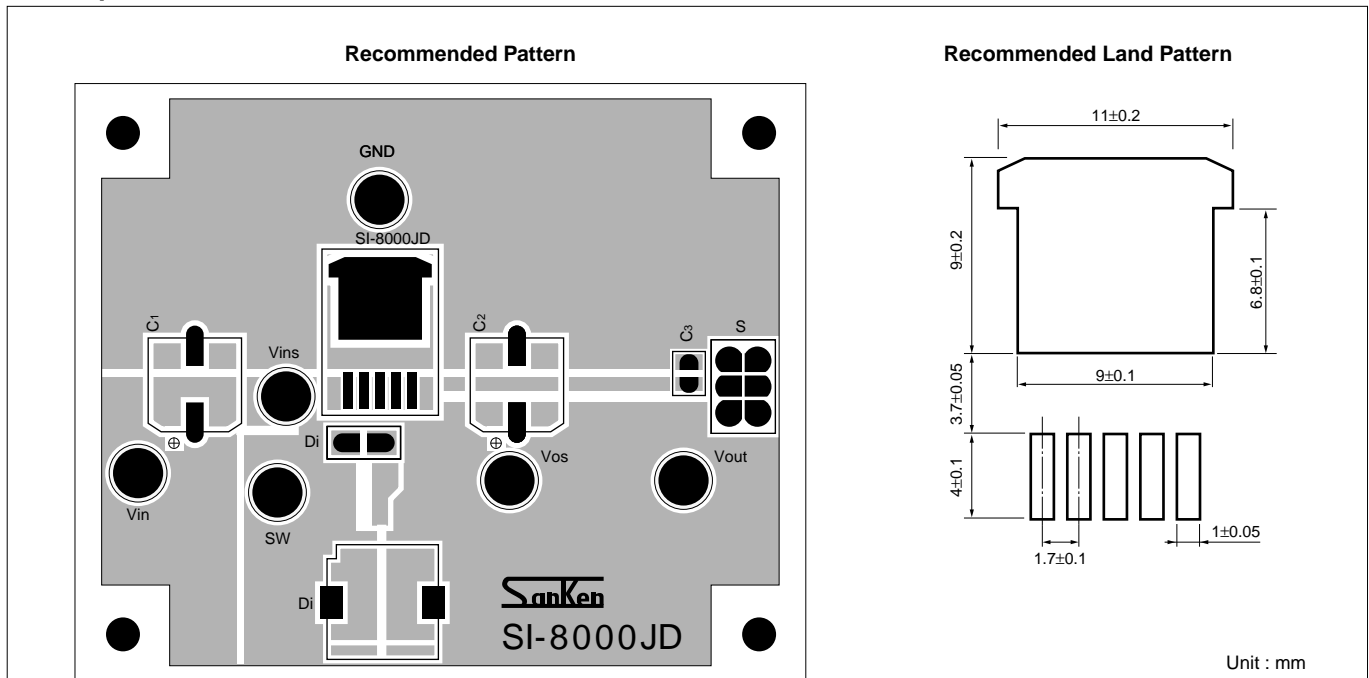

* For the optimum operating conditions, use one-point GND wiring centering on pin 3, and place each component as closely as possible.

Area of Copper on Glass Epoxy Board vs. Thermal Resistance (Junction to Ambient Air) (Typical Value)

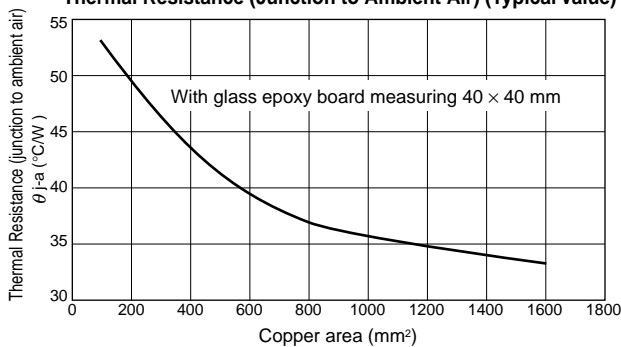

Output Current vs. Power Dissipation (Typical)

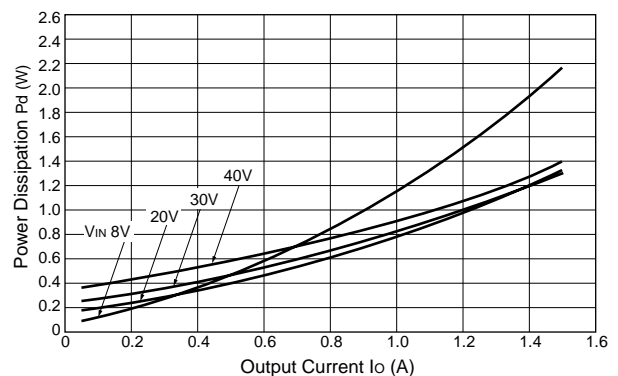

■T_a-P_D Characteristics

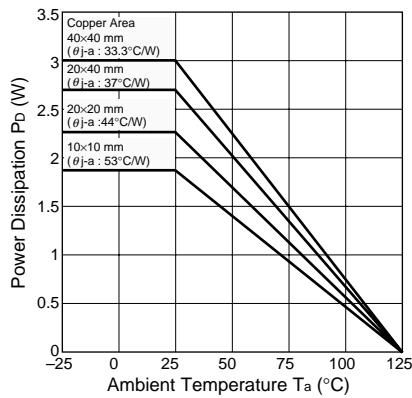

$$P_D = V_O \cdot I_O \left(\frac{100}{\eta\chi} - 1 \right) - V_F \cdot I_O \left(1 - \frac{V_O}{V_{IN}} \right)$$

The efficiency depends on the input voltage and the output current. Therefore, obtain the value from the efficiency characteristic curve and substitute the percentage in the formula above.

V_O : Output Voltage
 V_{IN} : Input Voltage
 I_O : Output Current
 $\eta\chi$: Efficiency (%)
 V_F : D₁ forward voltage
 0.4V(I_O=2A)(SFPB-66)

Thermal design for D₁ must be done separately.

■Selecting External Components

1. Inductor L₁

- ① It must be suitable for a switching regulator.
Do not use inductors such as for noise filters, because they generate excessive heat.
- ② The rated current must be satisfied.
If the rated current is exceeded, magnetic saturation leads to overcurrent.

2. Capacitor C₁, C₂

- ① The breakdown voltage and allowable ripple current must be satisfied.
Exceeding the ratings of these capacitors or using them without derating shortens their service lives and may also cause abnormal oscillation of the IC.
- ② Use a low-impedance type capacitor for C₂.
C₂ must be a low-impedance type capacitor to ensure reduced ripple voltage and a stable switching operation.
- ③ Do not use a capacitor that has an extremely small ESR (equivalent series resistance) such as an OS capacitor or tantalum capacitor.
- ④ C₃ is a capacitor for soft start. When not using soft start, leave pin 5 open. It is pulled up inside the IC.

3. Diode D₁

The Sanken SFPB-66 diode is recommended for D₁. If you intended to use an equivalent diode, be sure to use a Schottky Barrier diode. If you use a fast recovery diode or any other diode, supplying a reverse voltage generated from the recovery or ON voltage of the diode may damage the IC.

Application

Variable output voltage

Output voltage can be adjusted in the same way as SI-8000S.

■Typical Characteristics

Efficiency Characteristics
(SI-8033JD)

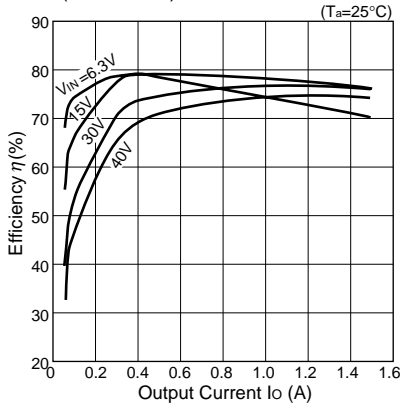

(SI-8050JD)

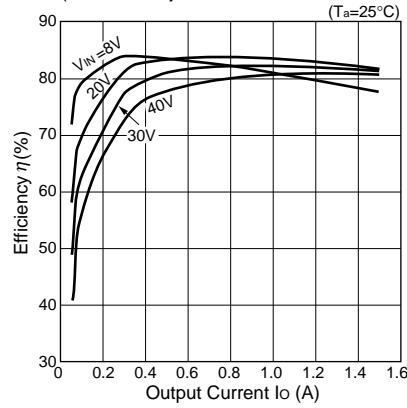

(SI-8090JD)

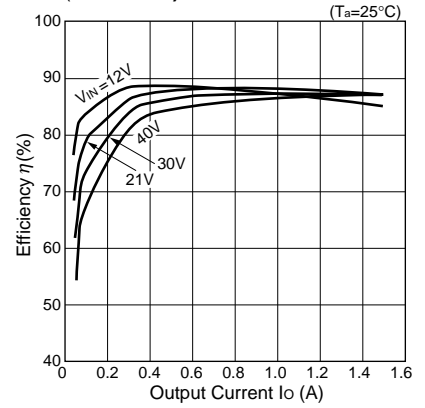

Output Voltage Characteristics
(SI-8033JD)

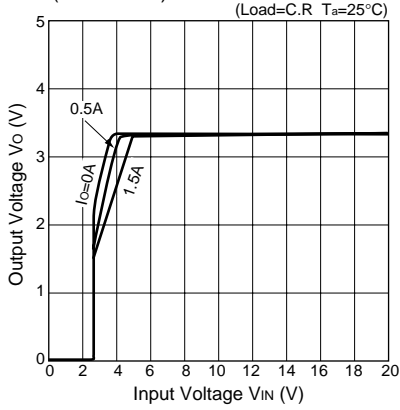

(SI-8050JD)

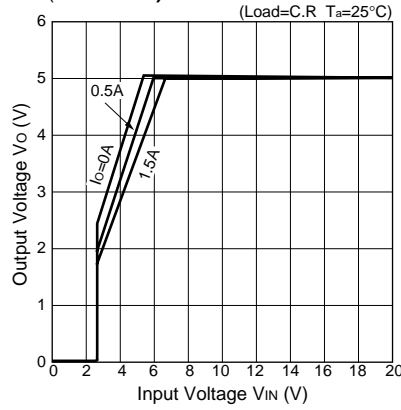

(SI-8090JD)

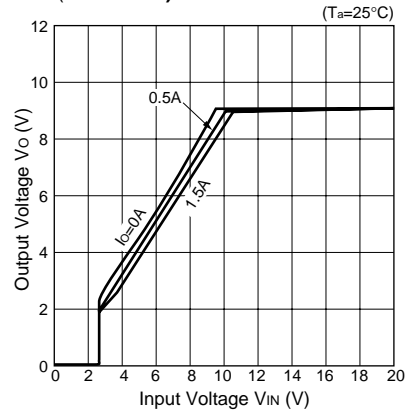

Load Regulation (SI-8033JD)

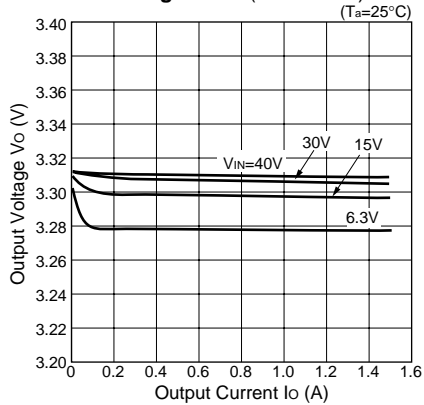

(SI-8050JD)

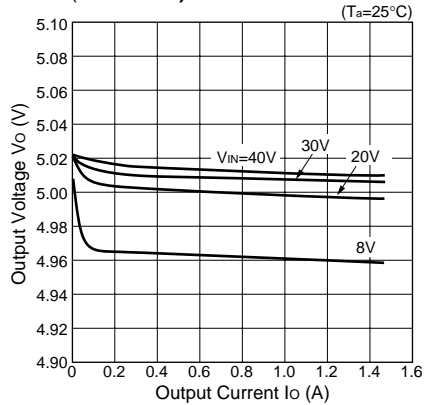

(SI-8090JD)

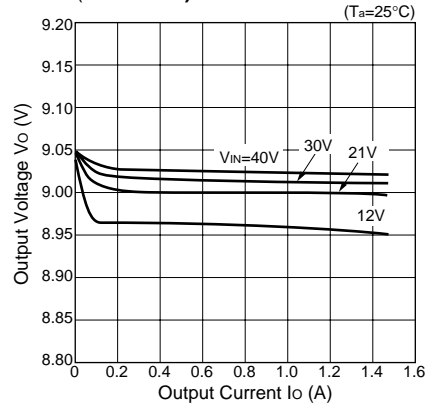

Overcurrent Protection Characteristics
(SI-8033JD)

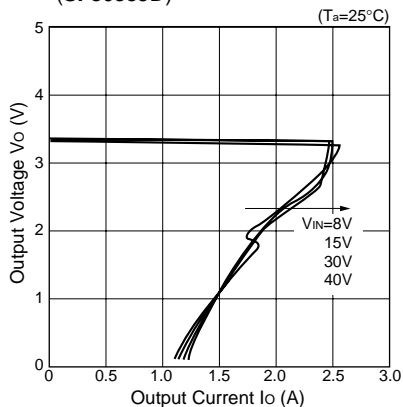

(SI-8050JD)

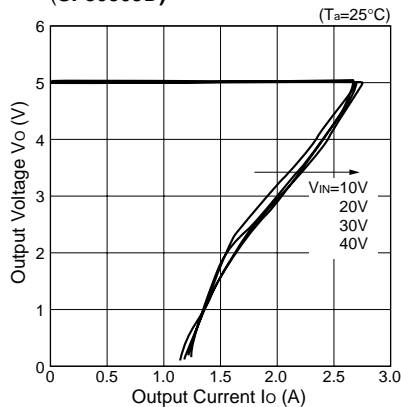

(SI-8090JD)

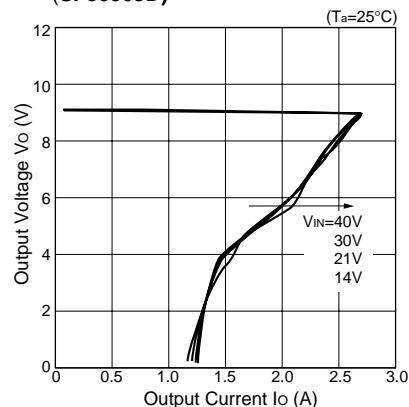

Thermal Protection Characteristics
(SI-8033JD)

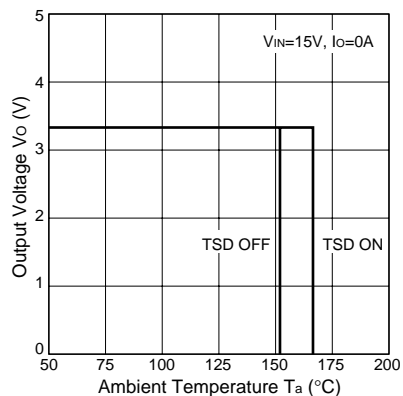

(SI-8050JD)

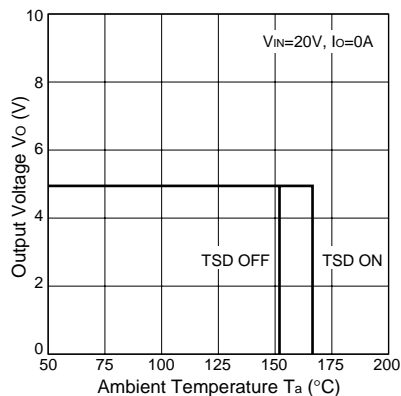

(SI-8090JD)

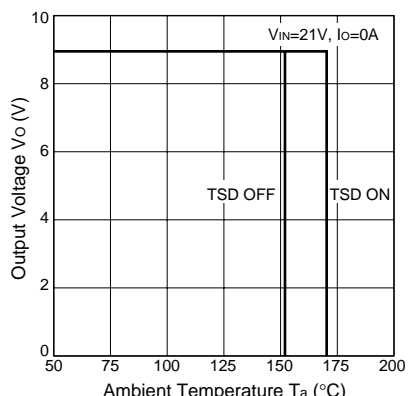

[Note on Thermal Protection]

The thermal protection circuit is intended for protection against heat during instantaneous short-circuiting. Its operation is not guaranteed for continuous heating conditions such as short-circuiting over extended periods of time.

Temperature Characteristics
(SI-8033JD)

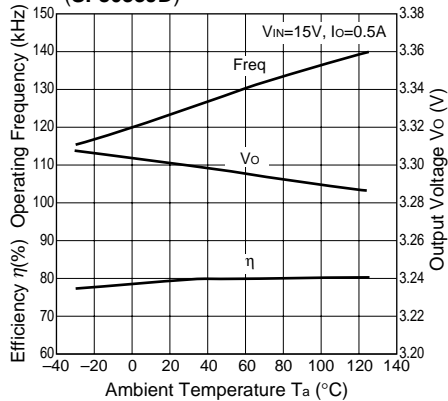

(SI-8050JD)

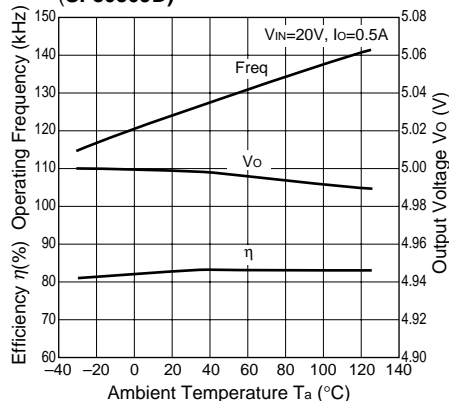

(SI-8090JD)

