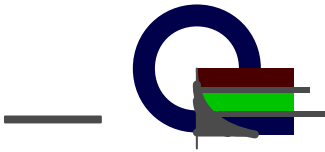

Prepared by: <b>Date</b> May 17, '04	 <b>Quanta Display Inc.</b> <b>SPECIFICATION</b>	<b>Doc. No. QD26WL01-05</b>
		<b>Doc. Rev. : 05</b>
<b>Issue Date :Jan.6,'05</b>		
<b>Page: 22 pages</b> ( Include cover page, drawing)		

Specification for  
TFT LCD Module  
Model No. QD26WL01 REV:05

**Customer's Approval**

**Date** \_\_\_\_\_

**by** \_\_\_\_\_

**Approved**

**By** \_\_\_\_\_



**These specification sheets are the proprietary product of Quanta Display Inc. ("QDI") and include materials protected under copyright of QDI. Do not reproduce or cause any third party to reproduce them in any form or by any means, electronic or mechanical, for any purpose, in whole or in part, without the express written permission of QDI.**

**The device listed in these technical literature sheets was designed and manufactured for use in OA equipment.**

**In case of using the device for applications such as control and safety equipment for transportation (aircraft, trains, automobiles, etc.), rescue and security equipment and various safety related equipment which require higher reliability and safety, take into consideration that appropriate measures such as fail-safe functions and redundant system design should be taken.**

**Do not use the device for equipment that requires an extreme level of reliability, such as aerospace applications, telecommunication equipment (trunk lines), nuclear power control equipment and medical or other equipment for life support.**

**QDI assumes no responsibility for any damage resulting from the use of the device, which does not comply with the instructions, and the precautions specified in these technical literature sheets.**

**Contact and consult with a QDI sales representative for any questions about this device.**



**Revision History**

REV.	Date	ECN NO.	Change Content
1	5/17/2004	N/A	Preliminary specification Initiate
2	7/1/2004	N/A	Update model name from QD26WL01 REV02 to QD26WL01 REV05
3	9/24,'04	N/A	Page 15, update CR, Luminance min. spec.
4	Nov.29,'04	N/A	Page 15, update Luminance min. spec.
5	Jan.5,'05	N/A	Page 12, add 6-3. inverter electric characteristic



## Content List

	<b>Page</b>
<b>1. Application</b>	<b>5</b>
<b>2. Overview</b>	<b>5</b>
<b>3. General Specifications</b>	<b>5</b>
<b>4. Input Terminals</b>	<b>6</b>
<b>5. Absolute Maximum Ratings</b>	<b>9</b>
<b>6. Electrical Characteristics</b>	<b>10</b>
<b>7. Timing Characteristics</b>	<b>13</b>
<b>8. Input Signals, Basic Display Colors and Gray Scale of Each Color</b>	<b>15</b>
<b>9. Optical Characteristics</b>	<b>16</b>
<b>10. Display Quality</b>	<b>18</b>
<b>11. Handling Precautions</b>	<b>18</b>
<b>12. Reliability Test Items</b>	<b>19</b>
<b>13. Others</b>	<b>19</b>
<b>14. Drawing</b>	<b>21</b>



## 1. Application

This specification applies to a color TFT-LCD module, QD26WL01

## 2. Overview

This module is a color active matrix LCD module incorporating amorphous silicon TFT (Thin Film Transistor). It is composed of a color TFT-LCD panel; driver ICs, control circuit and power supply circuit and a backlight unit. Graphics and texts can be displayed on a 1280 × 3 × 768 dots panel with 16.7 million colors by using the LVDS (Low Voltage Differential Signaling) interface, 8-bit driving method and supplying +12V DC supply voltage for TFT-LCD panel driving.

The TFT-LCD panel used for this module has fast response time. A low-reflection and higher-color-saturation type color filter is also used for this panel. Therefore, high-brightness and high-contrast image, which is suitable for multimedia use, can be obtained by using this module.

### [Features]

- 1) Brilliant and high contrast image.
- 2) Wide viewing angle.
- 3) Fast response time
- 4) WXGA resolution.
- 5) LVDS interface.
- 6) High color saturation

## 3. General Specifications

Parameter	Specifications	Unit
Display size	66.05 (26") Diagonal	cm
Active area	566.40 (H) × 339.84 (V)	mm
Pixel format	1280 (H) × 768 (V) (1 pixel = R+G+B dots)	Pixel
Pixel pitch	0.4425 (H) × 0.4425 (V)	mm
Pixel configuration	R,G,B vertical stripe	
Display mode	Normally Black	
Unit outline dimensions	595.4 x 366.4 x 39max	mm
Weight	3500 max.	g
Surface treatment	Anti-glare and hard-coating 3H	
Lamp Quantity	14	pcs



#### 4. Input Terminals

##### 4-1. TFT-LCD panel driving

CN1 (LVDS signals and +12V DC power supply)

Using connector: (DF14H-20P-1.25H (Hirose) or Equivalent)

Pin No.	Symbol	Function	Remark
1	VCC	+12V Input	
2	VCC	+12V Input	
3	GND	Ground	
4	GND	Ground	
5	Rx0-	Low Voltage Differential signal Input Data (-)	LVDS
6	Rx0+	Low Voltage Differential signal Input Data (+)	LVDS
7	GND	Ground	
8	Rx1-	Low Voltage Differential signal Input Data (-)	LVDS
9	Rx1+	Low Voltage Differential signal Input Data (+)	LVDS
10	GND	Ground	
11	Rx2-	Low Voltage Differential signal Input Data (-)	LVDS
12	Rx2+	Low Voltage Differential signal Input Data (+)	LVDS
13	GND	Ground	
14	RxCLK-	Low Voltage Differential signal Input Clock (-)	LVDS
15	RxCLK+	Low Voltage Differential signal Input Clock (+)	LVDS
16	GND	Ground	
17	Rx3-	Low Voltage Differential signal Input Data (-)	LVDS
18	Rx3+	Low Voltage Differential signal Input Data (+)	LVDS
19	GND	Ground	
20	GND	Ground	

www.DataSheet4U.com

**【Note 1】** All GND(ground) pins should be connected together (and to V<sub>SS</sub> which should also be connected to the LCDs metal frame).

**【Note 2】** All V<sub>CC</sub> (power supply) pins should be connected together.

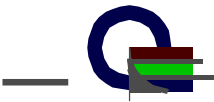

4-2 Interface block diagram

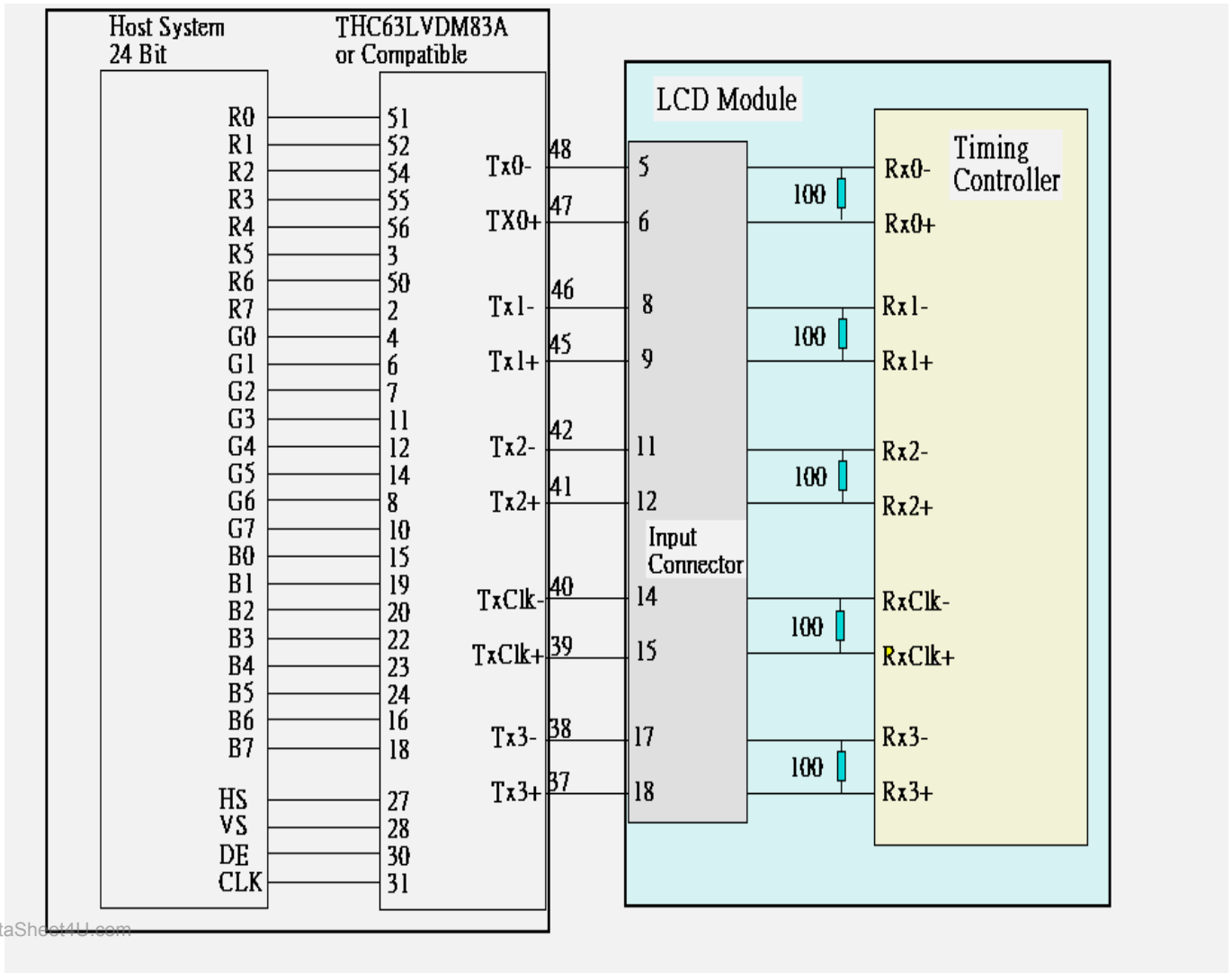



### 4-3. Backlight driving

Connector	Type	Manufactured
CN1	S12B-PH-SM3-TB	JST
CN2	SM02(12)B-BHS-1-TB	JST
CN3	S2B-ZR-SM2-TF	Hirose

Mating connector of CN1 : PHR-12(JST) or Equivalent

Pin No.	Symbol	Description	Remark
1	VDDDB	Power Input +24V	
2	VDDDB	Power Input +24V	
3	VDDDB	Power Input +24V	
4	NC	Not connection	
5	PWSEL	Select of luminance control signal method	See Luminance Control
6	BRTP	PWM signal	See Luminance Control
7	BRTI	Luminance by voltage method	See Luminance Control
8	BRTC	Backlight On/OFF signal	High : High or Open , Low: Low
9	SGND	Signal GND	
10	GND	Backlight Ground	Connected to metal frame
11	GND	Backlight Ground	
12	GND	Backlight Ground	

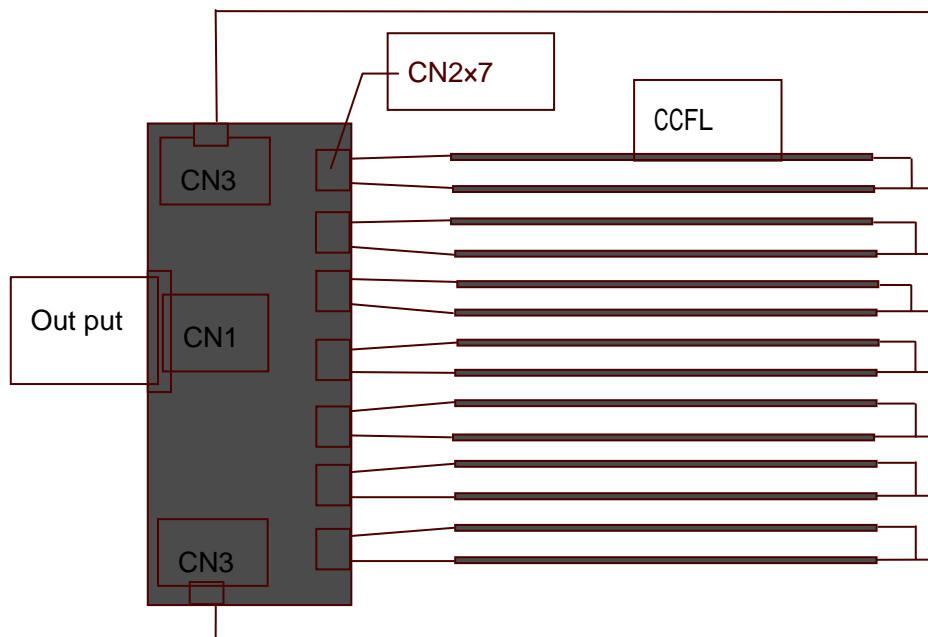





## 5. Absolute Maximum Ratings

### LCD module

Parameter	Symbol	Condition	Ratings	Unit	Remark
+12V supply voltage	$V_{CC}$	$T_a=25$	-0.3 ~ +14.0	V <sub>DC</sub>	
Storage temperature	Tstg	-	-20 ~ +60		【Note1】
Operating temperature (Ambient)	Topa	-	0 ~ +50		

【Note1】 Humidity : 90%RH Max. at  $T_a = 40$  .

Maximum wet-bulb temperature at 39 or less at  $T_a > 40$  .

No condensation.

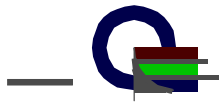

## 6. Electrical Characteristics

### 6-1. TFT-LCD panel driving

Ta = 25

Parameter		Symbol	Min.	Typ.	Max.	Unit	Remark
Vcc	Supply voltage	Vcc	+11.4	+12	+12.6	V	【Note2】
	Current dissipation	Icc	-	-	500	m A	【Note3】
	Rush current	Iccs			3.0	A	
	Permissive input ripple voltage	Vrp			120	mV	
Differential input threshold voltage	High	V <sub>TH</sub>	-	-	+100	mV	V <sub>CM</sub> =+1.2V 【Note1】
	Low	V <sub>TL</sub>	-100	-	-	mV	
Input current (High)		I <sub>OH</sub>	-	-	+/-10	μ A	V <sub>I</sub> =2.4V Vcc=3.6V
Input current (Low)		I <sub>OL</sub>	-	-	+/-10	μ A	V <sub>I</sub> =0V Vcc=3.6V
Terminal resistor		R <sub>T</sub>	-	100	-		Differential input

【Note1】 V<sub>CM</sub> : Common mode voltage of LVDS driver.

【Note2】

Power On-off sequence

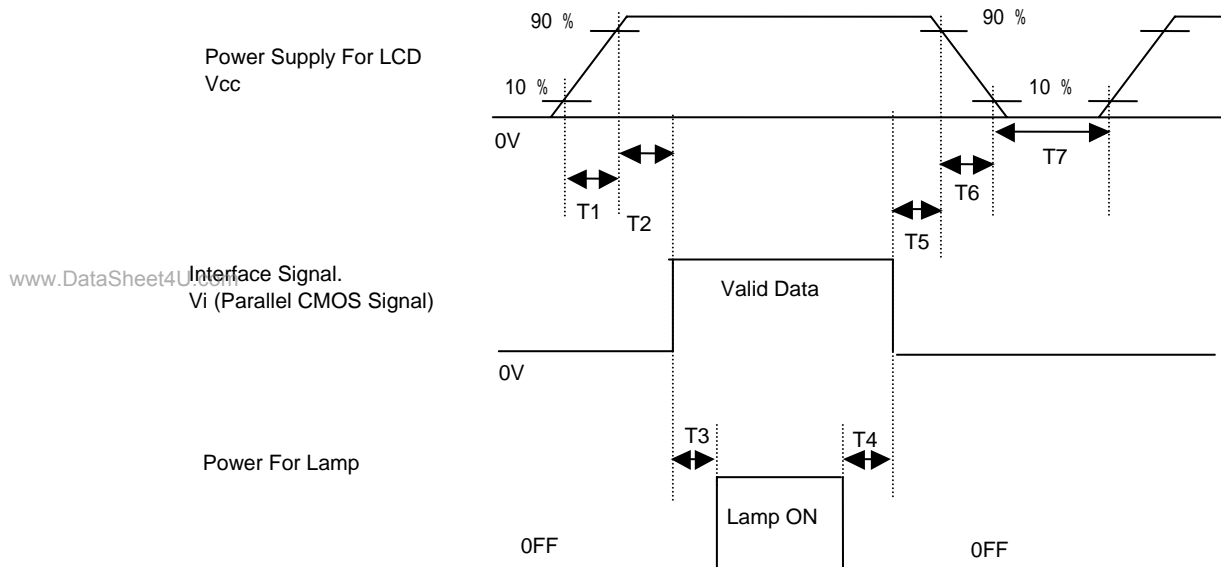

1ms < T1, T6    10 ms    0 ms < T2, T5    50 ms    200ms < T3, T4    T7 > 400ms

【Note3】 Maximum current condition; Change to 1x1 dot checker board pattern. V<sub>DD</sub>=+12V

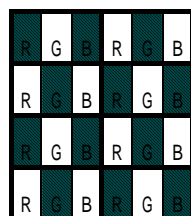

□ : 0 GS

■ : 255 GS



## 6-2. Backlight driving

The backlight system is a direct-lighting type with 14 CCFT (Cold Cathode Fluorescent Tube).

The characteristics of the lamp are shown in the following table.

Parameter	Symbol	Min.	Typ.	Max.	Unit	Remark
<b>Inverter</b>						
Lamp current	$I_L$	4.2	4.7	5.1	mArms	
Lamp voltage	$V_L$	890	990	1090	Vrms	
Lamp power consumption	$P_L$		4.65		W	【Note2】 $I_L=4.7mA$
Lamp frequency	$F_L$	50	52	60	kHz	【Note3】
Established starting voltage	$V_s$			1400	Vrms	$T_a=25$
				1820	Vrms	$T_a=0$
Lamp life time	$L_L$	50000			hour	【Note5】

【Note1】 Lamp current is measured with current meter for high frequency as shown below.

www.DataSheet4U.com

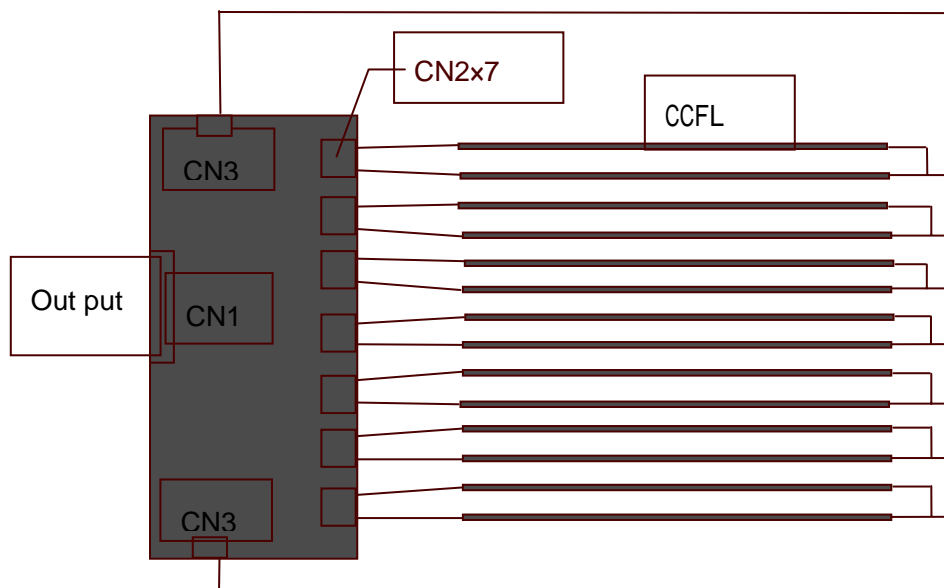

【Note2】 Calculated Value for reference ( $I_L \times V_L$ )

【Note3】 Lamp frequency may produce interference with horizontal synchronous frequency, and this may cause beat on the display. Therefore lamp frequency shall be detached as much as possible from the horizontal synchronous frequency and from the harmonics of horizontal

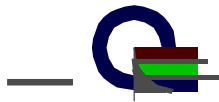

synchronous to avoid interference.

**【Note4】** The voltage above this value should be applied to the lamp for more than 1 second to start-up. Otherwise the lamp may not be turned on.

**【Note5】** The life is determined as the time at which luminance of the lamp is 50% compared to that of initial value at the typical lamp current on condition of continuous operating at  $25 \pm 2^\circ\text{C}$ .

**Note) 1.** The performance of the backlight, for example life time or brightness, is much influenced by the characteristics of the DC-AC inverter for the lamp. When you design or order the inverter, please make sure that a poor lighting caused by the mismatch of the backlight and the inverter (miss-lighting, flicker, etc.) never occur. When you confirm it, the module should be operated in the same condition as it is installed in your instrument.

**2.** Protection function : if one lamp cannot light on well, the inverter will shut down all lamps.

### 6-3. Inverter Electrical Characteristics

Parameter	Symbol	Min.	Typ.	Max.	Unit	Notes
Power Supply Input Voltage	V <sub>DDB</sub>	22.8	24	25.2	V <sub>dc</sub>	
Power Supply Input Current	I <sub>DDB</sub>	-	3300	3700	mA	TBD
Power Consumption	P <sub>B</sub>	-	79.2	93.2	W	TBD

**Note) 1.** The performance of the backlight, for example life time or brightness, is much influenced by the characteristics of the DC-AC inverter for the lamp. When you design or order the inverter, please make sure that a poor lighting caused by the mismatch of the backlight and the inverter (miss-lighting, flicker, etc.) never occur. When you confirm it, the module should be operated in the same condition as it is installed in your instrument.

**2.** Protection function : if one lamp cannot light on well, the inverter will shut down all lamps.

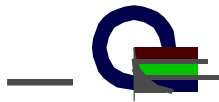

## 7. Timing characteristics of LCD module input signals

### 7-1. Timing characteristics

(This is specified at digital outputs of LVDS driver.)

ITEM	Symbol	Min	Typ	Max	Unit	Notes
DCLK	Frequency	$F_{CLK}$	-	80	82	MHz
	Period	$t_{CLK}$	12.2	12.5	-	ns
Hsync	Period	$t_{HA}$	1337	1648	1780	$t_{CLK}$
	Width-Active	$t_{HC}$	8	16	-	
	Frequency	$f_H$	44	48.54	52	kHz
Vsync	Frequency	$f_V$	47	60	63	Hz
	Period	$t_{VA}$	774	810	-	$t_{HA}$
	Width-Active	$t_{VC}$	2	6	-	
Data Enable	Horizontal back porch	$t_{HD}$	8	80	-	$t_{CLK}$
	Horizontal front porch	$t_{HF}$	16	272	-	$t_{CLK}$
	Horizontal active	$t_{HE}$	1280	1280	1280	$t_{CLK}$
	Horizontal blanking	$t_{HB}$	57	368		$t_{CLK}$
	Vertical back porch	$t_{VD}$	2	20	-	$t_{HA}$
	Vertical front porch	$t_{VF}$	2	16	-	$t_{HA}$
	Vertical active	$t_{VE}$	768	768	768	$t_{HA}$
	Vertical blanking	$t_{VB}$	6	42		$t_{HA}$

Notes: 1. The performance of electro-optical characteristics may be influenced by variance of the vertical refresh rates.

2. Hsync period shall be a double number of character (8).

### 7-2 Signal Timing Waveform

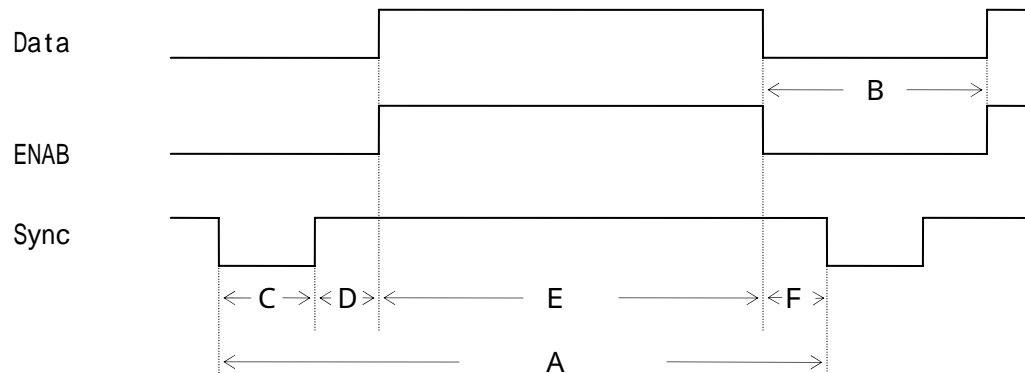

### 7-3. Input Data Signals and Display Position on the screen



Display position of input data  
( H , V )

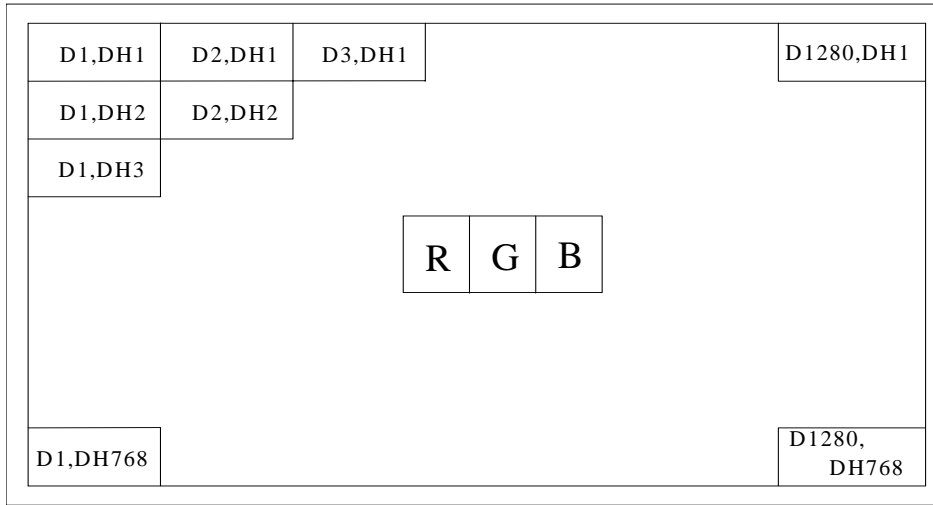

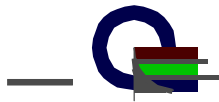

**8. Input Signals, Basic Display Colors and Gray Scale of Each Color**

	Colors & Gray scale	Data Signal															
		R R R R R4 R5 R6 R7	G G1 G2 G G G5 G6 G7	B0 B1 B2 B3 B4 B5 B6 B7													
		0 1 2 3	0 3 4														
<b>Basic Color</b>	Black	0 0 0 0 0 0 0 0	0 0 0 0 0 0 0 0	0 0 0 0 0 0 0 0													
	Blue	0 0 0 0 0 0 0 0	0 0 0 0 0 0 0 0	1 1 1 1 1 1 1 1													
	Green	0 0 0 0 0 0 0 0	1 1 1 1 1 1 1 1	0 0 0 0 0 0 0 0													
	Cyan	0 0 0 0 0 0 0 0	1 1 1 1 1 1 1 1	1 1 1 1 1 1 1 1													
	Red	1 1 1 1 1 1 1 1	0 0 0 0 0 0 0 0	0 0 0 0 0 0 0 0													
	Magenta	1 1 1 1 1 1 1 1	0 0 0 0 0 0 0 0	1 1 1 1 1 1 1 1													
	Yellow	1 1 1 1 1 1 1 1	1 1 1 1 1 1 1 1	0 0 0 0 0 0 0 0													
	White	1 1 1 1 1 1 1 1	1 1 1 1 1 1 1 1	1 1 1 1 1 1 1 1													
<b>Gray Scale of Red</b>	Black	0 0 0 0 0 0 0 0	0 0 0 0 0 0 0 0	0 0 0 0 0 0 0 0													
	↑	1 0 0 0 0 0 0 0	0 0 0 0 0 0 0 0	0 0 0 0 0 0 0 0													
	Darker	0 1 0 0 0 0 0 0	0 0 0 0 0 0 0 0	0 0 0 0 0 0 0 0													
	↑																
	↓																
	Bright	1 0 1 1 1 1 1 1	0 0 0 0 0 0 0 0	0 0 0 0 0 0 0 0													
	↓	0 1 1 1 1 1 1 1	0 0 0 0 0 0 0 0	0 0 0 0 0 0 0 0													
	Red	1 1 1 1 1 1 1 1	0 0 0 0 0 0 0 0	0 0 0 0 0 0 0 0													
<b>Gray Scale of Green</b>	Black	0 0 0 0 0 0 0 0	0 0 0 0 0 0 0 0	0 0 0 0 0 0 0 0													
	↑	0 0 0 0 0 0 0 0	1 0 0 0 0 0 0 0	0 0 0 0 0 0 0 0													
	Darker	0 0 0 0 0 0 0 0	0 1 0 0 0 0 0 0	0 0 0 0 0 0 0 0													
	↑																
	↓																
	Bright	0 0 0 0 0 0 0 0	1 0 1 1 1 1 1 1	0 0 0 0 0 0 0 0													
	↓	0 0 0 0 0 0 0 0	0 1 1 1 1 1 1 1	0 0 0 0 0 0 0 0													
	Green	0 0 0 0 0 0 0 0	1 1 1 1 1 1 1 1	0 0 0 0 0 0 0 0													
<b>Gray Scale of Blue</b>	Black	0 0 0 0 0 0 0 0	0 0 0 0 0 0 0 0	0 0 0 0 0 0 0 0													
	↑	0 0 0 0 0 0 0 0	0 0 0 0 0 0 0 0	1 0 0 0 0 0 0 0													
	Darker	0 0 0 0 0 0 0 0	0 0 0 0 0 0 0 0	0 1 0 0 0 0 0 0													
	↑																
	↓																
	Bright	0 0 0 0 0 0 0 0	0 0 0 0 0 0 0 0	1 0 1 1 1 1 1 1													
	↓	0 0 0 0 0 0 0 0	0 0 0 0 0 0 0 0	0 1 1 1 1 1 1 1													
	Blue	0 0 0 0 0 0 0 0	0 0 0 0 0 0 0 0	1 1 1 1 1 1 1 1													



0 : Low level voltage, 1 : High level voltage

9. Optical Characteristics

Ta=25 , VCC=+12V

Parameter		Symbol	Condition	Min.	Typ.	Max.	Unit	Remark
Viewing angle range	L/R	21, 22	CR>10	85	88		Deg.	【Note1,4】
	U	11		85	88		Deg.	
	D	12		85	88		Deg.	
Contrast ratio		C R n	=0 °	500	600	-		【Note2,4】
Response time				-	25		ms	【Note3,4】
Rise time	r				20		ms	
Fall time	d				5		ms	
Chromaticity of White (CIE 1931)		Wx		0.256	0.286	0.316		【Note4】
		Wy		0.277	0.307	0.337		
Chromaticity of Red (CIE 1931)		Rx		0.615	0.645	0.675		
		Ry		0.308	0.338	0.368		
Chromaticity of Green (CIE 1931)		Gx		0.252	0.282	0.312		
		Gy		0.586	0.616	0.646		
Chromaticity of Blue (CIE 1931)		Bx		0.113	0.143	0.173		
		By		0.049	0.079	0.109		
Luminance of white 【Note4】		Y <sub>L</sub>		400	450		Cd/m <sup>2</sup>	
White Uniformity		W <sub>(SP)</sub>		-	-	1.25		【Note5】

The measurement shall be executed 30 minutes after lighting at rating. (typical condition : I<sub>L</sub> = 4.7 mA/Arms)

The optical characteristics shall be measured in a dark room or equivalent state with the method shown in Fig.3 below.

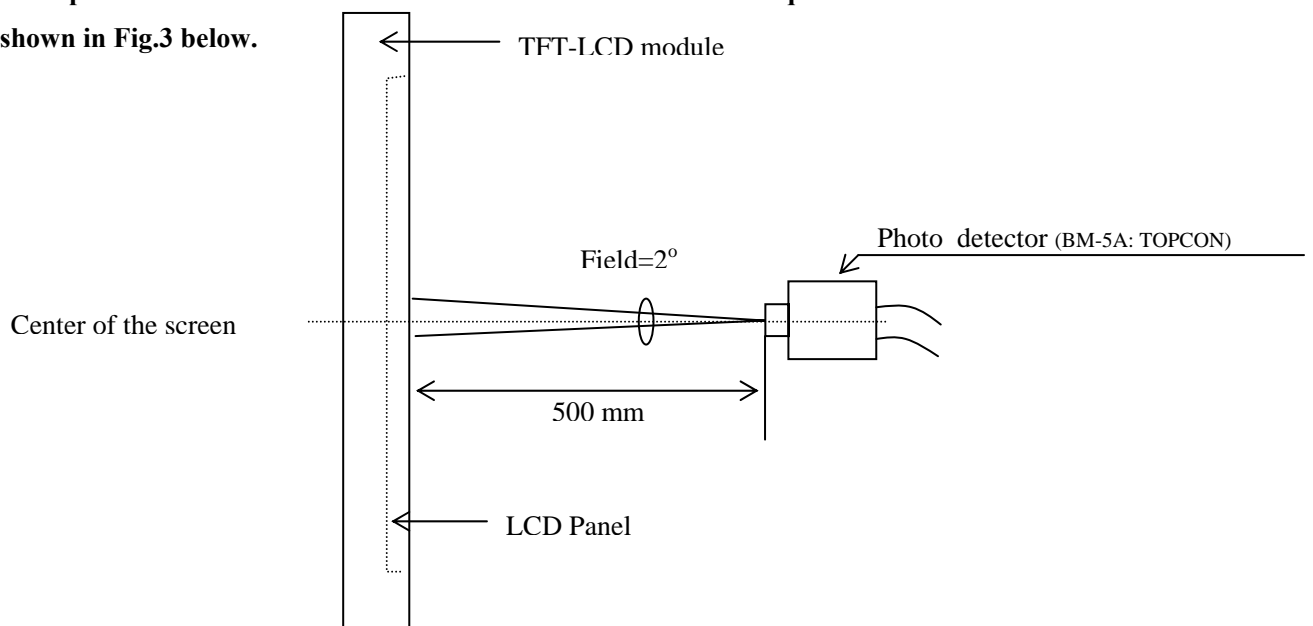
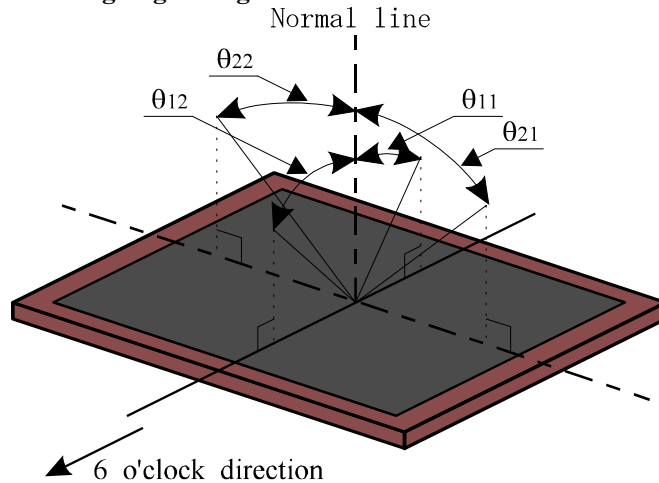

Fig 1. Optical characteristics measurement method





**【Note1】 Definitions of viewing angle range:**



**【Note2】 Definition of contrast ratio:**

The contrast ratio is defined as the following.

$$\text{Contrast Ratio (CR)} = \frac{\text{Luminance (brightness) with all pixels white}}{\text{Luminance (brightness) with all pixels black}}$$

**【Note3】 Definition of response time:**

The response time is defined as the following figure and shall be measured by switching the input signal for "black" and "white".

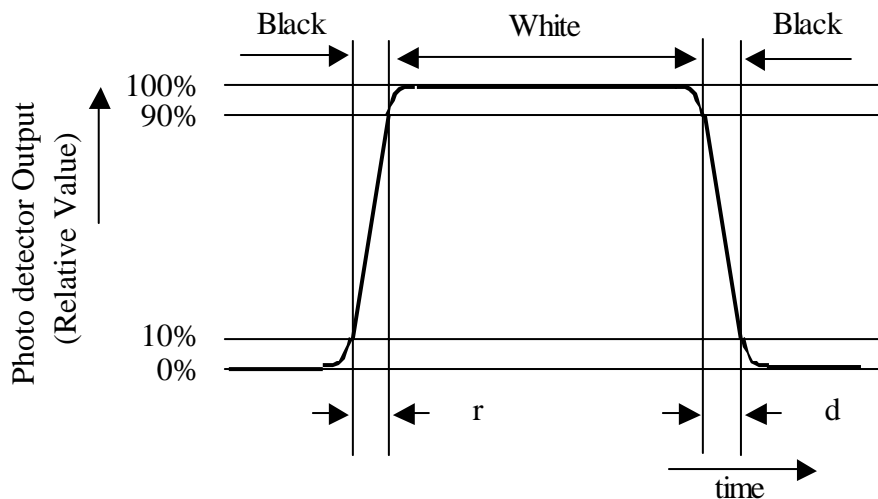

**【Note4】 This shall be measured at center of the screen.**

**【Note5】 Definition of white uniformity:**

White uniformity is defined as the following the number of measurement points within active area, formula are  $\delta_w(5)(A \sim E)$ .  $H \times V$  : active area

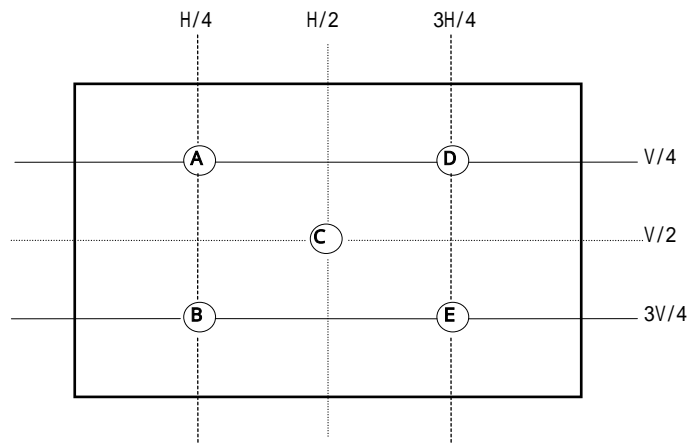

$$\delta_w = \frac{\text{Maximum Luminance (of 5 points measurement)}}{\text{Minimum Luminance (of 5 points measurement)}}$$

**10. Display Quality**

The display quality of the color TFT-LCD module shall be in compliance with the Incoming Inspection Standard.

**11 . Handling Precautions**

- a) Be sure to turn off the power supply when inserting or disconnecting the cable.
- b) Be sure to design the cabinet so that the module can be installed without any extra stress such as warp or twist.
- c) Since the front polarizer is easily damaged, pay attention not to scratch it.
- d) Wipe off water drop immediately. Long contact with water may cause discoloration or spots.
- e) When the panel surface is soiled, wipe it with absorbent cotton or other soft cloth.
- f) Since the panel is made of glass, it may break or crack if dropped or bumped on hard surface.  
Handle with care.
- g) Since CMOS LSI is used in this module, take care of static electricity and injure the human earth when handling.
- h) Observe all other precautionary requirements in handling components.
- i) This module has its circuitry PCBs on the rear side and should be handled carefully in order not to be stressed.
- j) Laminated film is attached to the module surface to prevent it from being scratched . Peel the film off slowly just before the use with strict attention to electrostatic charges. Ionized air shall be blown over during the action. Blow off the 'dust' on the polarizer by using an ionized nitrogen gun, etc..

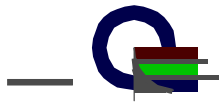

**12. Reliability test items**

No.	Test item	Conditions
1	High temperature storage test	Ta = 70 240h
2	Low temperature storage test	Ta = -30 240h
3	High temperature & high humidity operation test	Ta = 50 ; 95%RH 240h (No condensation)
4	High temperature operation test	Ta = 60 240h
5	Low temperature operation test	Ta = 0 240h
6	Vibration test (non- operating)	Frequency: 10 ~ 500Hz, 1.0G , 1Hr/each axis
7	Shock test (non- operating)	Gravity : 50G Pulse width : 11 ms, half sine wave Direction : ± X, ± Y, ± Z Once for each direction.
8	ESD	Contact-op:+-8kv, Contact-nop: +-10kv, Air-op:+-15kv, Air-nop: +-20kv, (contact area is limited on metal bezel)

**13 . Others**

1) Lot No. Label:

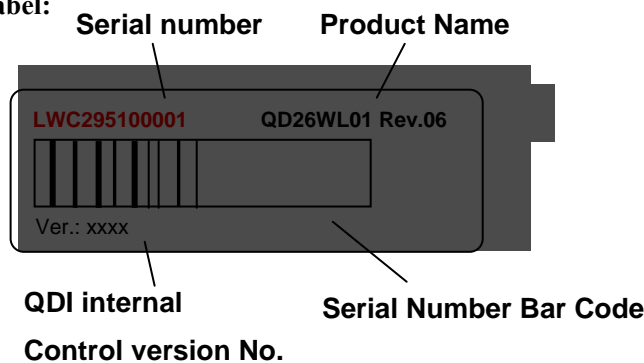

www.DataSheet4U.com

**Control version No.**

LWC295100001 Digital code 4, 5 is Date code.

Digital 4 (Year) 1: 2001, 2: 2002, 3:2003,....

Digital 5 (Month) 1: Jan, 2: Feb,... , A:Oct, B:Nov., C: Dec.

- 2) Adjusting volume has been set optimally before shipment, so do not change any adjusted value.  
If adjusted value is changed, the specification may not be satisfied.
- 3) Disassembling the module can cause permanent damage and should be strictly avoided.
- 4) Please be careful since image retention may occur when a fixed pattern is displayed for a long time.
- 5) If any problem occurs in relation to the description of this specification, it shall be resolved through discussion with spirit of cooperation.
- 6) UL certification number : E216479-A3-UL-1  
TUV certification number : R50031484.





### 14. Drawing

Front View

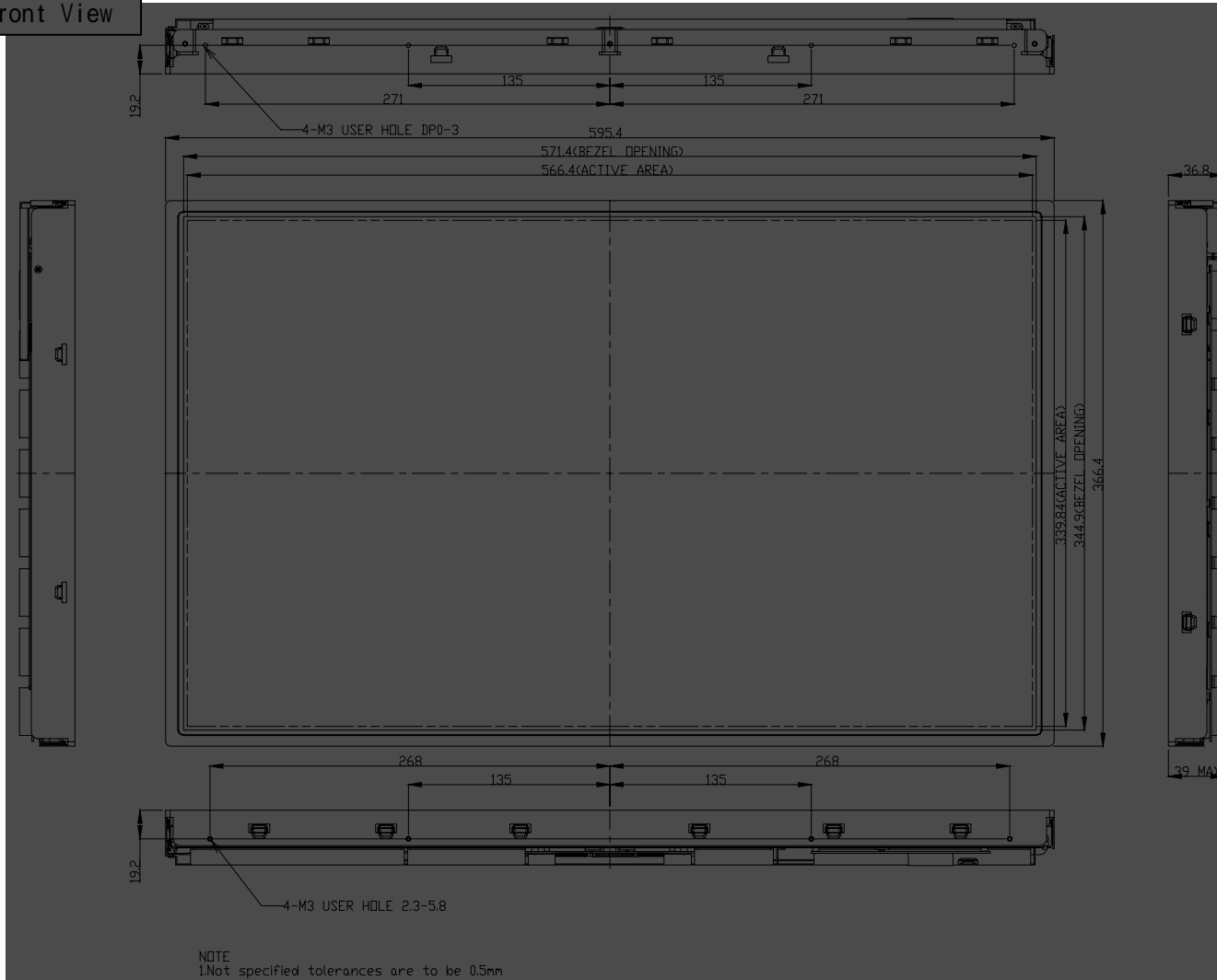



Back View

