

DUAL-CORE 64-BIT MIPS® PROCESSOR WITH SPI-4/HT (NEW!)

FEATURES

- **Two 64-bit MIPS® CPUs, scalable from 800 MHz–1.2 GHz**
 - Quad issue in-order pipeline with dual-execute and dual-memory pipes
 - Enhanced skew pipeline enables a zero load-to-use penalty
 - 32-KB instruction cache and 32-KB data cache (ECC protected)
- **Fast on-chip multiprocessor bus**
 - Connects the CPUs, L2 cache, memory controller, and I/O bridges
 - Runs at half the CPU core frequency and is 256 bits wide
- **On-chip L2 cache**
 - 1 MB shared by two CPUs and I/O agents
 - Eight-way associative, ECC protected
 - Any way can be programmed as fast on-chip RAM
- **DDR memory controller**
 - Memory bandwidth as high as 100 Gbps
 - Configurable as 2x64-bit or 4x32-bit wide channels
 - Runs up to 400-MHz clock rate, 800-MHz data rate
 - Support for DDR, DDR2, and FCRAM
- **Three independent, 19.2 full-duplex ports**
 - Configurable as 16/8-bit HyperTransport™ (HT) or Channelized OIF SPI-4 Phase 2
 - Runs up to 600 MHz DDR for aggregate bandwidth of 38.4 Gbps per port
 - Includes Intelligent Hash and Filter Engine on each port to route packets
 - Supports glueless connectivity of multiple **BCM1280** devices to build a distributed shared-memory system with hardware-based coherency
- **On-chip switch**
 - Connects multiprocessor bus to high-speed interfaces
 - 256-Gbps bisection bandwidth
 - Supports both packet transfer and memory transactions
- **Integrated network and system I/O**
 - Four Gigabit-Ethernet MACs configurable as packet FIFO interfaces
 - 64-bit PCI-X interface at 133 MHz
 - Generic I/O for direct connect to boot ROM, flash memory
 - Two SMBus serial configuration interfaces
 - PCMCIA control interface and up to 16 interrupts
 - Four UART interfaces
- **On-chip debug capability**
 - EJTAG
 - Bus trace unit (internal logic analyzer)
- **Support for leading operating systems, including VxWorks®, Linux®, QNX®, and NetBSD**
- **Evaluation board platform available with samples (includes tools, firmware, and software drivers)**

SUMMARY OF BENEFITS

- **Industry-leading performance**
 - 2.5 Dhrystone MIPS/MHz per CPU
 - 10 Million packets per second of L3 forwarding
 - 128 Gbps (@ 1.0 GHz) on-chip bus bandwidth, with 100 Gbps memory bandwidth and 145 Gbps I/O bandwidth
- **Low-power dissipation of 17W @ 1 GHz**
- **High functional integration, reducing overall system cost**
- **Programming ease and flexibility based on MIPS64™ instruction set architecture (ISA)**
- **Software compatible with BCM1250 and BCM112x**
- **Broad tools and system software support**

APPLICATIONS

Because of its world-class performance, power efficiency, and integration, the **BCM1280** processor is ideal for a broad variety of applications, including:

- Enterprise-class routers and switches
- Multifunction security platforms (VPN/SSL/IDS)
- High-end RAID Arrays
- SAN routers/gateways/switches
- Wireless infrastructure platforms (e.g., RNC, GGSN, MSC)

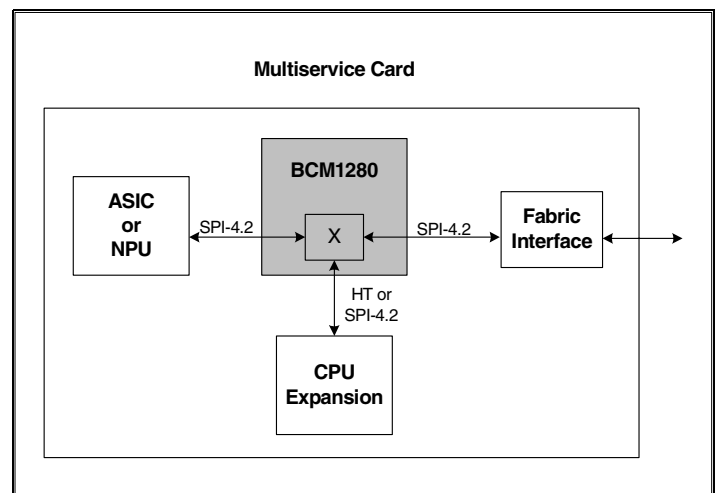

OVERVIEW

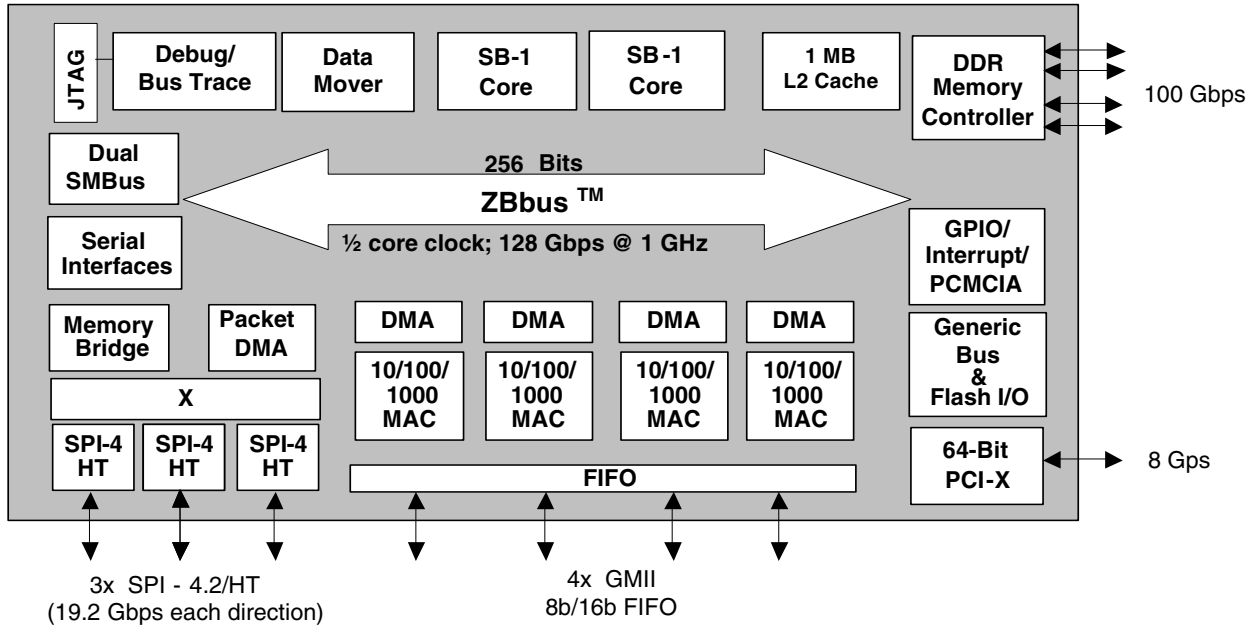

The **BCM1280** device is an MIPS64 processor core-based system-on-a-chip (SOC) that offers industry-leading performance, high functional integration, and low-power levels required by next-generation computing, storage, and networking applications.

The **BCM1280** is a scalable chip multiprocessor (CMP) system consisting of two Broadcom SB-1 high-performance MIPS64 CPUs, a shared 1-MB L2 cache, a DDR memory controller, and integrated I/O. All major blocks of the processor are connected together via the ZBbus, a high-speed, split-transaction multiprocessor bus. The bus implements the standard MESI protocol to ensure coherency between the two CPUs, L2 cache, I/O agents, and memory. In addition, the **BCM1280** supports an interchip ccNUMA protocol for cache coherent distributed shared memory systems. The three high-speed HT ports provide interchip communications to other **BCM1280** processors or to HT bridging I/O chips. Each port can optionally be configured as an SPI-4 Phase 2 packet interface for connectivity to 10 Gbps network devices. Four Gigabit-Ethernet MACs (10/100/1000) enable easy interfacing to LANs or control backplanes. To enable higher data rates (or in cases where Ethernet protocol processing is not required), the Gigabit-Ethernet MACs can be configured as 8-bit and/or 16-bit packet FIFOs. The **BCM1280** also integrates a 64-bit, 133-MHz PCI-X local bus for direct connection to I/O devices. Four serial ports are available for use as UARTs for console ports.

To enable low-chip count systems, the **BCM1280** also includes a configurable generic bus that allows glueless connection of a boot ROM or flash memory and simple I/O peripherals. On-chip debug, trace, and performance monitoring functions assist both hardware and software designers in debugging and tuning the system. The system can be run in either big-endian or little-endian mode.

Implementation of MIPS64 ISA

The SB-1 CPU core is a high-performance implementation of the standard MIPS64 ISA that incorporates the MIPS-3D and MIPS-MDMX application-specific extensions (ASEs). The core supports a 4-issue enhanced skew pipeline and can dispatch up to two memory and two ALU (integer, floating point, MDMX, or MIPS-3D) instructions per cycle.

Next Generation Broadband Processors

| | BCM1255 | BCM1280 | BCM1455 | BCM1480 |
|---------------------|------------|------------|------------|------------|
| # of CPUs | 2 | 2 | 4 | 4 |
| L2 Cache | 512 KB | 1 MB | 1 MB | 1 MB |
| DDR2 Support | Yes | Yes | Yes | Yes |
| # of MACs | 4 GMII | 4 GMII | 4 GMII | 4 GMII |
| PCI-X | 1 x 64-bit | 1 x 64-bit | 1 x 64-bit | 1 x 64-bit |
| # of SPI-4/HT Ports | 0 | 3 | 0 | 3 |

Broadcom®, the pulse logo, and Connecting everything® are trademarks of Broadcom Corporation and/or its subsidiaries in the United States and certain other countries. All other trademarks are the property of their respective owners.

Connecting
everything®



BROADCOM CORPORATION
16215 Alton Parkway, P.O. Box 57013
Irvine, California 92619-7013

© 2004 by BROADCOM CORPORATION. All rights reserved.

1280-PB01-R 09/30/04

Phone: 949-450-8700
Fax: 949-450-8710
E-mail: info@broadcom.com
Web: www.broadcom.com