

LA4592W**SANYO****1.5-V Preamplifier + Power Amplifier
for Headphone Stereo Products****Overview**

The LA4592W is a single-chip 1.5-V headphone stereo system IC. The LA4592W adds a variety of functions, including a switch amplifier (for end product audio quality switches, the metal tape switch, and other switches) and an AMSS (Automatic Music Search System) function that supports blank skipping, to the earlier LA4590W. Furthermore, the LA4592W provides even lower no-signal time power levels for lower end-product power dissipation. In combination with the LA3235W 1.5-V record preamplifier IC, the LA4592W can be used to implement a record/playback cassette system with just two ICs.

Functions

- Stereo preamplifier: supports auto reverse and includes a muting function.
- Stereo power amplifier: Includes OCL and muting

functions.

- Ripple filter
- Low boost function (BTL operation in the low-frequency region)
- Inter-track detection function (Supports AMSS and blank skipping)
- Two switching amplifiers
- Power switch (standby function)

Features

- Virtual ground impedance is reduced by built-in V_{REF} amplifier
- No capacitor required for ripple filter oscillation prevention.
- Provides ample output power at low frequencies. ($P_O = 24 \text{ mW}$, $V_{CC} = 1.2 \text{ V}$, $f = 150 \text{ Hz}$)
- High-frequency cutoff capacitors built into the preamplifier and power amplifier inputs to minimize buzzing.

Package Dimensions

unit: mm

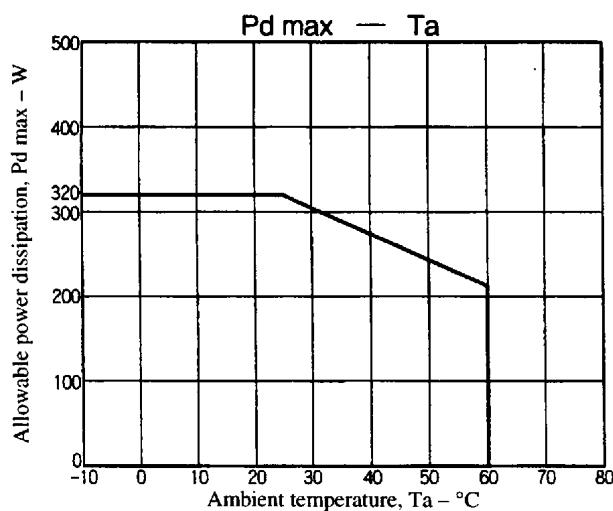
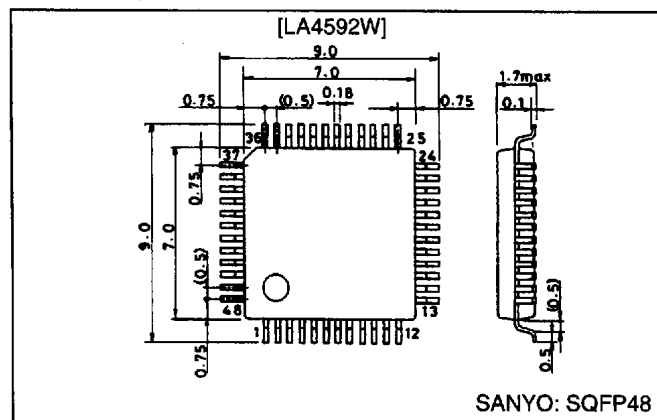
3163A-SQFP48**Specifications****Maximum Ratings at $T_a = 25^\circ\text{C}$**

Parameter	Symbol	Conditions	Ratings	Unit
Maximum supply voltage	$V_{CC \text{ max}}$		3.0	V
Allowable power dissipation	$P_d \text{ max}$		320	mW
Operating temperature	T_{opr}		-10 to +60	°C
Storage temperature	T_{stg}		-40 to +125	°C

Allowable Operating Ranges at $T_a = 25^\circ\text{C}$

Parameter	Symbol	Conditions	Ratings	Unit
Recommended supply voltage	V_{CC}		1.5	V
Operating supply voltage range	V_{CCOP}		0.95 to 2.2	V

LA4592W

**Operating Characteristics at Ta = 25°C, V_{CC} = 1.2 V, f = 1 kHz, 0.775 V = 0 dB, R_L = 10 kΩ (preamplifier)
R_L = 16 Ω (power amplifier)**

Parameter	Symbol	Conditions	Ratings			Unit
			min	typ	max	
[PRE + PWR]						
Quiescent current	I _{CCO1}	R _g = 2.2 kΩ, R _v = 0 Ω	8.5	11	16	mA
	I _{CCO2}	With the power switch off		0.1	5	μA
Voltage gain (closed loop)	V _{G_T}	V _O = -20 dBm, R _v = 10 kΩ	54	57	60	dB
[PRE AMP]						
Voltage gain (open loop)	V _{G₀}	V _O = -20dBm	60	68		dB
Voltage gain (closed loop)	V _{G₁}	V _O = -20dBm	34	35.3	37	dB
Maximum output voltage	V _{O max1}	THD = 1 %	100	210		mV
Total harmonic distortion	THD1	V _G = 35.3 dB/NAB, V _O = 100 mV		0.08	0.5	%
Equivalent input noise voltage	V _{N1}	R _g = 2.2 kΩ, BPF = 20 Hz to 20 kHz		1.3	3.0	μV
Interchannel crosstalk	CT1	R _g = 2.2 kΩ, TUNE 1 kHz, V _O = -20 dBm	45	56		dB
F/R crosstalk	CT2	R _g = 2.2 kΩ, TUNE 1 kHz, V _O = -20 dBm	65	78		dB
Ripple rejection ratio	R _{r1}	R _g = 2.2 kΩ, V _r = -30 dBm, f _r = 100 Hz, TUNE 100 Hz	45	52		dB
Muting output voltage	V _{M1}	V _{IN} = -40 dBm, TUNE 1 kHz, With the muting function on			-90	dBm
[Low Boost + Power Amplifier]						
Voltage gain (closed loop)	V _{G₃}	V _O = -20 dBm	20.5	23	25.5	dB
	V _{G₄}	V _O = -20 dBm, L.B = ON	20.5	23	25.5	dB
	V _{G₅}	V _O = -20 dBm, L.B = ON, f = 10 kHz	24.5	27.5	30.5	dB
	V _{G₆}	V _O = -20 dBm, L.B = ON, f = 100 Hz	28	32	36	dB
Output voltage	P _{O1}	THD = 10 %	5	9		mW
	P _{O2}	THD = 10 %, f = 100 Hz, L.B = ON	13	19		mW
Total harmonic distortion	THD2	P _O = 1 mW		0.3	1.5	%
Interchannel crosstalk	CT3	V _O = -20 dBm, R _v = 0 Ω	38	43		dB
Output noise voltage	V _{NO}	R _v = 0 Ω, BPF = 20 Hz to 20 kHz		20	33	μV
Ripple rejection ratio	R _{r2}	R _v = 0 Ω, V _r = -30 dBm, f _r = 100 Hz, TUNE 100 Hz	50	74		dB
Muting output voltage	V _{M2}	V _{IN} = -30 dBm, TUNE 1 kHz, With the muting function on			-90	dBm
Input resistance	R _i		8	10	12	kΩ
Voltage gain difference	ΔV _{G3}			0	1.5	dB
[Ripple Filter]						
Ripple rejection ratio	R _{r3}	f _r = 100 Hz, V _r = -30 dBm, V _{CC} = 1.0 V, I _{RF} = 25 mA, using a rank 6 2SB1295	33	39		dB
Output voltage	V _{RF}	V _{CC} = 1.0 V, I _{RF} = 25 mA	0.89	0.94		V
[AMSS]						
Operating output voltage	V _{OAMSS1}	The preamplifier output voltage when the AMSS V _O = 0.6 V p-o With the PWR muting on. (AMSS)	3.33	4.7	6.64	mV
Operating output voltage	V _{OAMSS2}	The preamplifier output voltage when the AMSS V _O = 0.6 V p-o With the PWR muting off. (BLANK SKIP)	479	675	953	μV
Operating output voltage	V _{OAMSS3}	The preamplifier output voltage when the AMSS V _O = 0.6 V p-o With pin 34 shorted through a 270-Ω resistor. With the PWR muting on.	2.62	3.7	5.23	mV
Operating output voltage	V _{OAMSS4}	The preamplifier output voltage when the AMSS V _O = 0.6 V p-o With pin 34 shorted through a 270-Ω resistor. With the PWR muting on.	375	530	749	μV
[SW AMP]						
Voltage gain (closed loop)	V _{G₇}	V _O = -25 dBm	-1.2	-0.7	-0.2	dB
Maximum output voltage	V _{O max2}	THD = 1 %	25	60		mV
Ripple rejection ratio	R _{r4}	With the input pins open, V _r = -30 dBm, f _r = 100 Hz, TUNE 100 Hz	50	75		dB
Output voltage when off	V _{M3}	V _{IN} = -20 dBm, TUNE 1 kHz, SW OFF			-90	dBm

LA4592W

AMSS Temperature Characteristics (Values for reference only)

Parameter	Symbol	Conditions	Ratings			Unit
			min	typ	max	
AMSS	Ta		-10	25	50	°C
Operating output voltage	V _{OAMSS1}	The preamplifier output voltage when the AMSS V _O = 0.6 V p-o With the PWR muting on. (AMSS)	3.9	4.7	5.4	mV
	V _{OAMSS2}	The preamplifier output voltage when the AMSS V _O = 0.6 V p-o	605	675	735	μV

Block Diagram

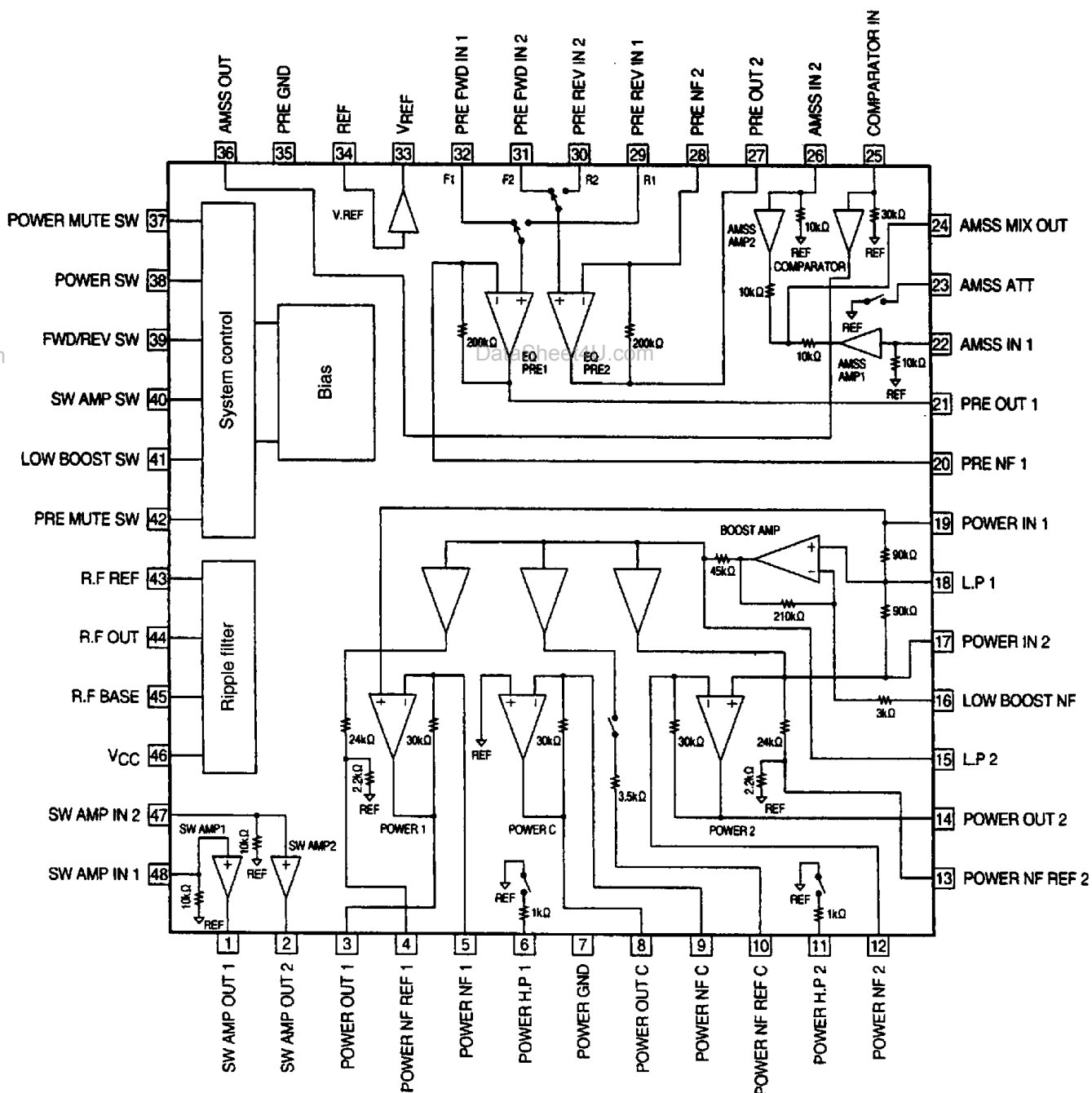

LA4592W

Test Circuit Diagram

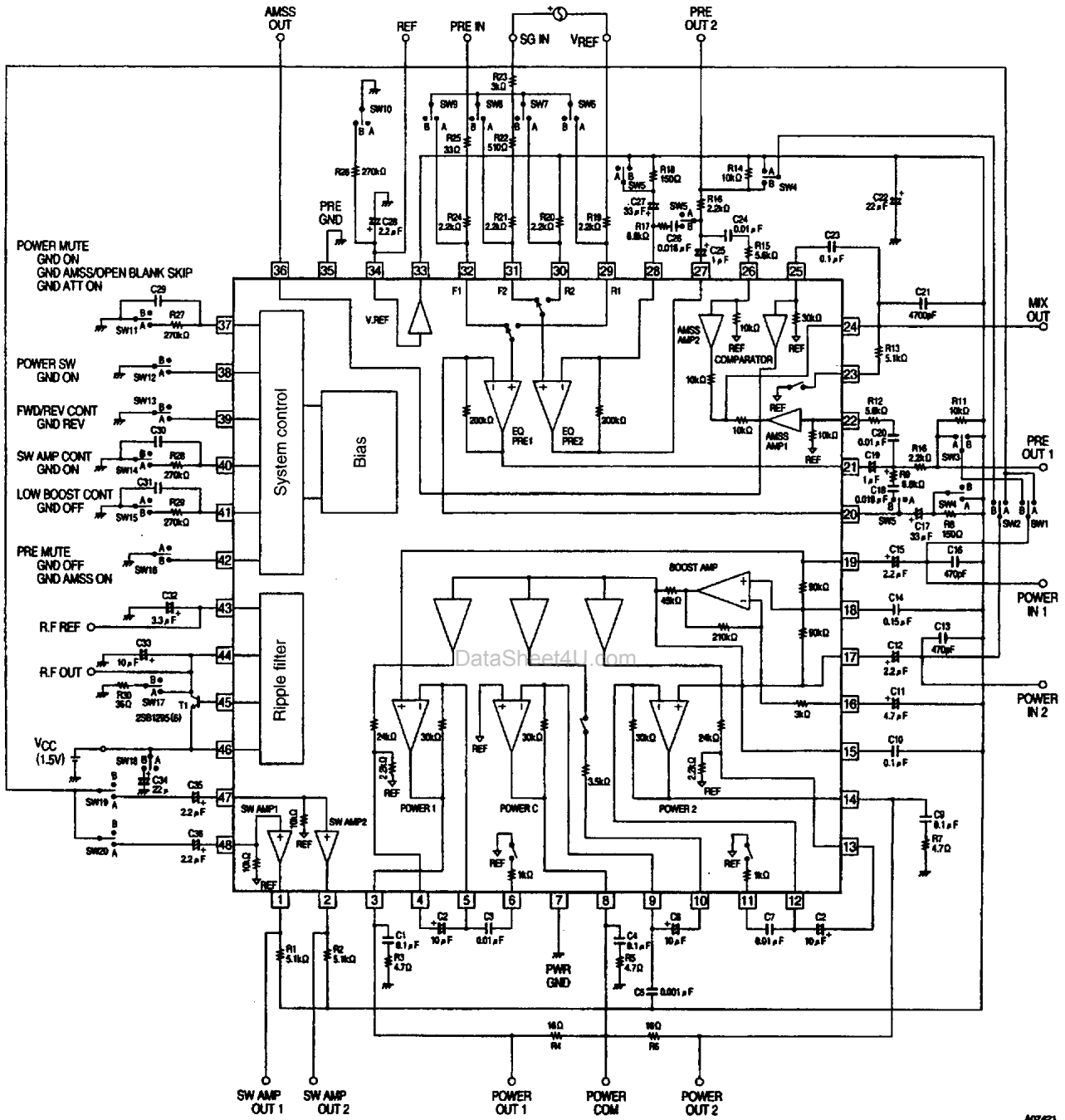

A07421

LA4592W

Sample Application Circuit

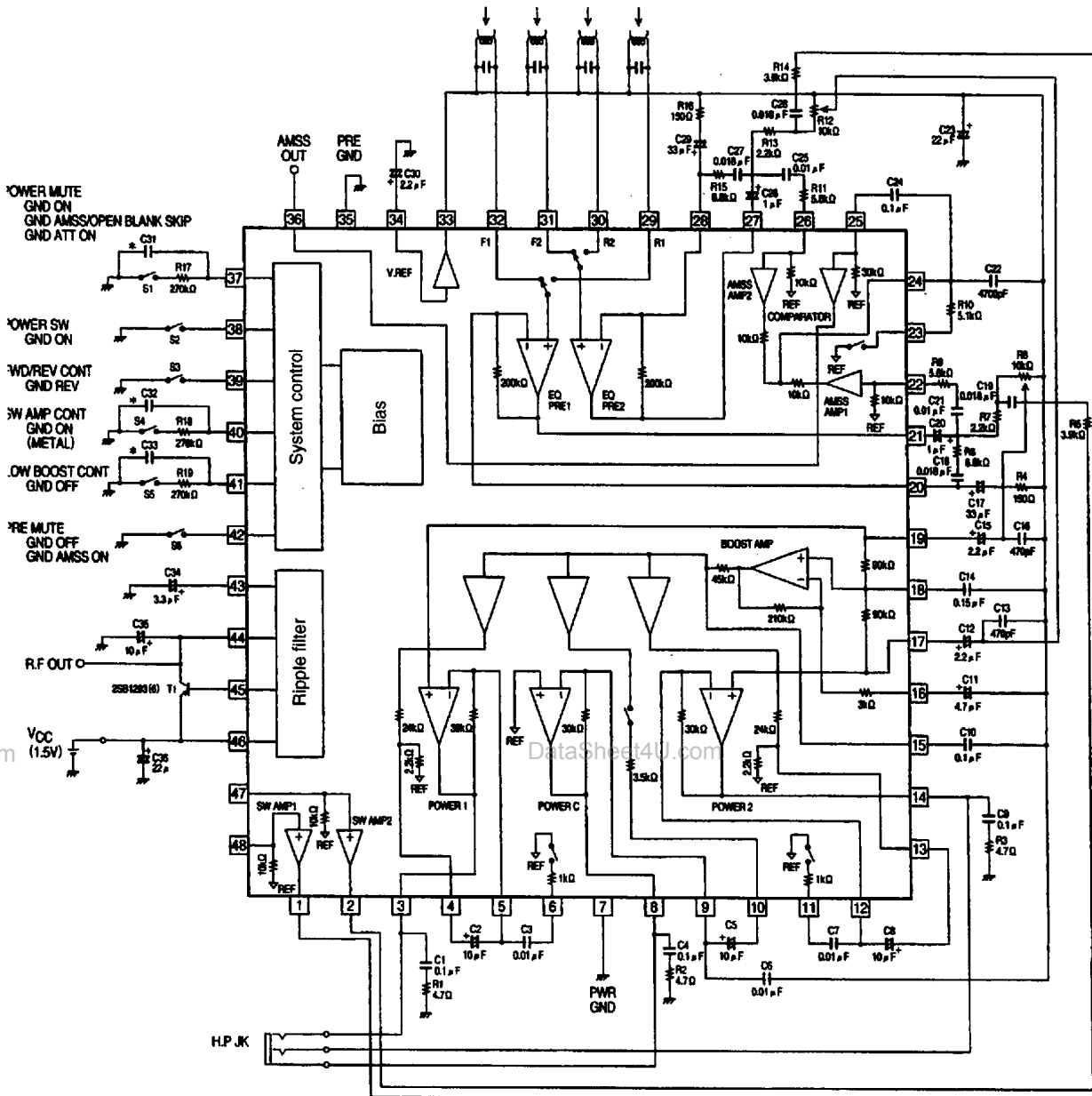

*: Adjust the values of the capacitors marked with an asterisk to match the timing required by the end product.

- No products described or contained herein are intended for use in surgical implants, life-support systems, aerospace equipment, nuclear power control systems, vehicles, disaster/crime-prevention equipment and the like, the failure of which may directly or indirectly cause injury, death or property loss.
- Anyone purchasing any products described or contained herein for an above-mentioned use shall:
 - ① Accept full responsibility and indemnify and defend SANYO ELECTRIC CO., LTD., its affiliates, subsidiaries and distributors and all their officers and employees, jointly and severally, against any and all claims and litigation and all damages, cost and expenses associated with such use:
 - ② Not impose any responsibility for any fault or negligence which may be cited in any such claim or litigation on SANYO ELECTRIC CO., LTD., its affiliates, subsidiaries and distributors or any of their officers and employees jointly or severally.
- Information (including circuit diagrams and circuit parameters) herein is for example only; it is not guaranteed for volume production. SANYO believes information herein is accurate and reliable, but no guarantees are made or implied regarding its use or any infringements of intellectual property rights or other rights of third parties.

This catalog provides information as of July, 1997. Specifications and information herein are subject to change without notice.