

Linear Systems replaces discontinued Siliconix 2N5114

This analog switch is designed for inverting switching into inverting input of an Operational Amplifier.

The SOT-23 package provides ease of manufacturing, and a lower cost assembly option.

(See Packaging Information).

LS5114 Benefits:

- Low On Resistance
- $I_{D(off)} \leq 500 \text{ pA}$
- Switches directly from TTL logic

LS5114 Applications:

- Analog Switches
- Commutators
- Choppers

FEATURES

DIRECT REPLACEMENT FOR SILICONIX 2N5114

LOW ON RESISTANCE $r_{DS(on)} \leq 75\Omega$

LOW CAPACITANCE 6pF

ABSOLUTE MAXIMUM RATINGS @ 25°C (unless otherwise noted)

Maximum Temperatures

Storage Temperature -55°C to +200°C

Operating Junction Temperature -55°C to +200°C

Maximum Power Dissipation

Continuous Power Dissipation 500mW

MAXIMUM CURRENT

Gate Current (Note 1) $I_G = -50\text{mA}$

MAXIMUM VOLTAGES

Gate to Drain Voltage $V_{GDS} = 30\text{V}$

Gate to Source Voltage $V_{GSS} = 30\text{V}$

LS5114 ELECTRICAL CHARACTERISTICS @ 25°C (unless otherwise noted)

SYMBOL	CHARACTERISTIC	MIN	TYP.	MAX	UNITS	CONDITIONS
BV_{GSS}	Gate to Source Breakdown Voltage	30	--	--	V	$I_G = 1\mu\text{A}, V_{DS} = 0\text{V}$
$V_{GS(off)}$	Gate to Source Cutoff Voltage	4	--	10		$V_{DS} = -15\text{V}, I_D = -1\text{nA}$
$V_{GS(F)}$	Gate to Source Forward Voltage	--	-0.7	-1		$I_G = -1\text{mA}, V_{DS} = 0\text{V}$
$V_{DS(on)}$	Drain to Source On Voltage	--	-1.0	-1.3	mV	$V_{GS} = 0\text{V}, I_D = -15\text{mA}$
		--	-0.7	--		$V_{GS} = 0\text{V}, I_D = -7\text{mA}$
		--	-0.5	--		$V_{GS} = 0\text{V}, I_D = -3\text{mA}$
I_{DSS}	Drain to Source Saturation Current (Note 2)	-30	--	-90	mA	$V_{DS} = -18\text{V}, V_{GS} = 0\text{V}$
I_{GSS}	Gate Reverse Current	--	5	500	pA	$V_{GS} = 20\text{V}, V_{DS} = 0\text{V}$
I_G	Gate Operating Current	--	-5	--		$V_{DS} = -15\text{V}, I_D = -1\text{mA}$
$I_{D(off)}$	Drain Cutoff Current	--	-10	-500		$V_{DS} = -15\text{V}, V_{GS} = 12\text{V}$
		--	-10	--	$V_{DS} = -15\text{V}, V_{GS} = 7\text{V}$	
		--	-10	--	$V_{DS} = -15\text{V}, V_{GS} = 5\text{V}$	
$r_{DS(on)}$	Drain to Source On Resistance	--	--	75	Ω	$I_D = -1\text{mA}, V_{GS} = 0\text{V}$

LS5114 DYNAMIC ELECTRICAL CHARACTERISTICS @ 25°C (unless otherwise noted)

SYMBOL	CHARACTERISTIC	MIN	TYP.	MAX	UNITS	CONDITIONS
g_{fs}	Forward Transconductance	--	4.5	--	mS	$V_{DS} = -15\text{V}, I_D = 1\text{mA}, f = 1\text{kHz}$
g_{os}	Output Conductance	--	20	--	μS	
$r_{DS(on)}$	Drain to Source On Resistance	--	--	75	Ω	$I_D = 0\text{A}, V_{GS} = 0\text{V}, f = 1\text{kHz}$
C_{iss}	Input Capacitance	--	20	25	pF	$V_{DS} = -15\text{V}, V_{GS} = 0\text{V}, f = 1\text{MHz}$
C_{rss}	Reverse Transfer Capacitance	--	5	7		$V_{DS} = 0\text{V}, V_{GS} = 12\text{V}, f = 1\text{MHz}$
		--	6	--		$V_{DS} = 0\text{V}, V_{GS} = 7\text{V}, f = 1\text{MHz}$
		--	6	--	$V_{DS} = 0\text{V}, V_{GS} = 5\text{V}, f = 1\text{MHz}$	
e_n	Equivalent Noise Voltage	--	20	--	nV/VHz	$V_{DG} = 10\text{V}, I_D = 10\text{mA}, f = 1\text{kHz}$

LS5114 SWITCHING CHARACTERISTICS @ 25°C (unless otherwise noted)

SYMBOL	CHARACTERISTIC	UNITS	CONDITIONS
$t_{d(on)}$	Turn On Time	6	$V_{GS(L)} = -11\text{V}$ $V_{GS(H)} = 0\text{V}$ See Switching Circuit
t_r	Turn On Rise Time	10	
$t_{d(off)}$	Turn Off Time	6	
t_f	Turn Off Fall Time	15	

Note 1 - Absolute maximum ratings are limiting values above which LS5114 serviceability may be impaired. Note 2 - Pulse test: $PW \leq 300 \mu\text{s}$, Duty Cycle $\leq 3\%$

LS5114 SWITCHING CIRCUIT PARAMETERS

V_{DD}	-10V
V_{GG}	20V
R_L	430 Ω
R_G	100 Ω
$I_{D(on)}$	-15mA

Available Packages:

LS5114 in SOT-23
LS5114 in bare die.

Please contact Micross for full package and die dimensions

SOT-23 (Top View)

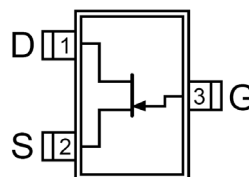

SWITCHING TEST CIRCUIT

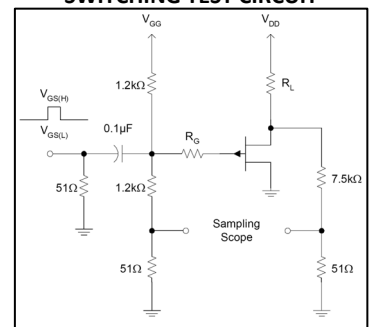

Micross Components Europe