

# XK3100

## 3 or 4 Cell Li-Ion Battery System Development Kit

### FEATURE

- Self contained Development Board (batteries not included)
- X3100 and microcontroller control
- External components provided
- PC connection and software
- SMBus hardware connection

### BENEFIT

- Speed system development
- Maximum flexibility to explore alternative implementations.
- Evaluate algorithmic trade-offs for Gas Gauging and Cell Balancing functions
- Minimize battery pack development issues
- Simple interface to special X3100 functions
- Speeds development of industry standard Smart Battery interface

### DESCRIPTION

The XK3100 is a development board that features the Xicor X3100 Lithium Ion battery protection and monitor IC. For use in battery packs consisting of 3 or 4 Lithium-ion battery cells, the X3100 provides:

- internal over-voltage, under-voltage, and over-current protection circuitry
- internal EEPROM memory
- circuits for externally monitoring cell voltages and pack current, including a current sense amplifier for higher resolution current measurements,
- an internal voltage regulator, and
- internal drive circuitry for switching external FET devices used to control cell charge, discharge, and cell voltage balancing.

The XK3100 board provides the external devices needed to control the battery pack and adds a microcontroller. This microcontroller talks to the PC through a 2-wire interface. The microcontroller provides a mechanism for interrogating the X3100 status, monitoring the pack voltages and current and controlling protection settings. The board provides an interface for attaching microcontroller development tools. This will facilitate the development of more complete battery pack software. Future revisions of the software and microcontroller firmware, may include: full SMBus support, battery gas gauging, cell balancing, and history tracking.

The XK3100 user interface consists of a Graphical User Interface program running on Windows 95/98. This software provides a menu driven method of setting the programmable elements of the X3100, monitoring the status of the batteries and reading the on-chip EEPROM. The XK3100 board and software will monitor and control all features of the X3100 device.

### Included in the XK3100

- |  |   |
|--|---|
| <ul style="list-style-type: none"> <li>• Fully assembled and tested board, complete with microcontroller, FETs, sense resistor and regulator circuits.</li> <li>• Win95/98 compatible executable program providing the user interface to the hardware.</li> <li>• Cable from the PC parallel port to the XK3100</li> </ul> | <ul style="list-style-type: none"> <li>• Two samples of the X3100</li> <li>• Users Manual</li> <li>• X3100 Data Sheet</li> <li>• Board schematics and layout information</li> <li>• Two application notes.</li> </ul> |
|--|---|

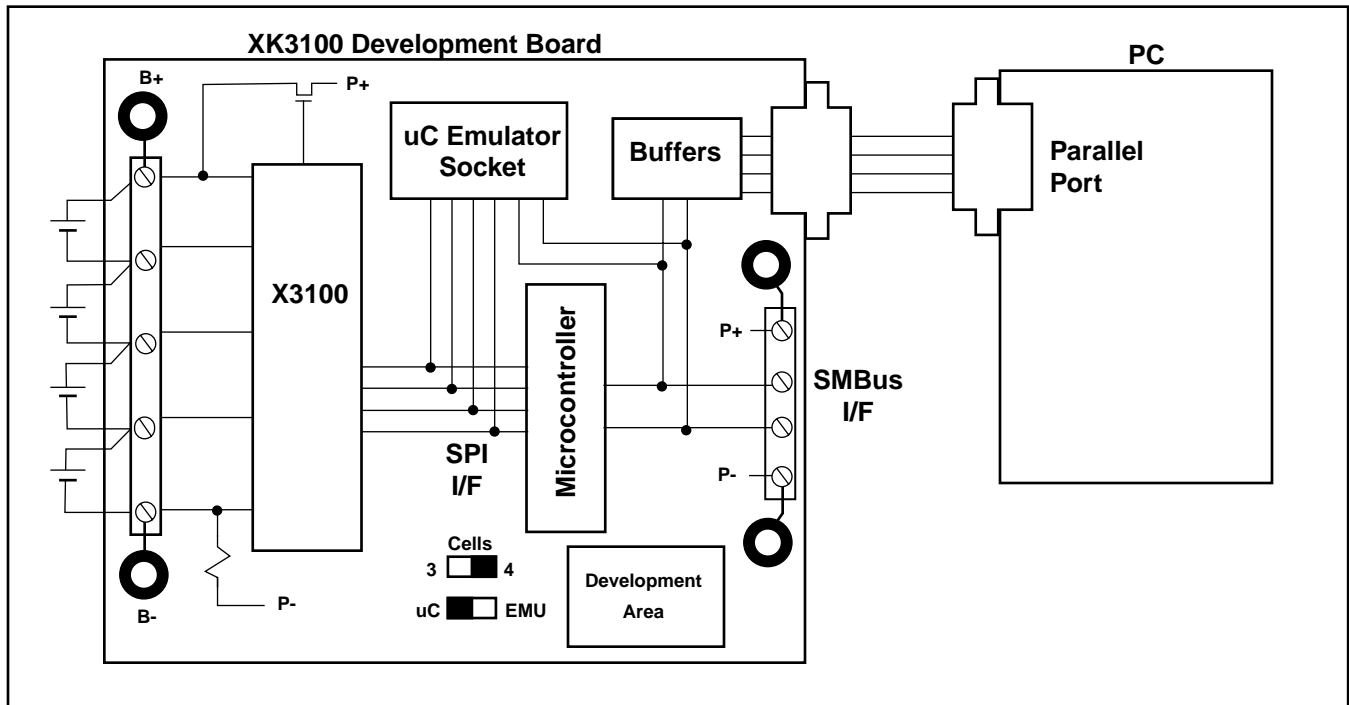
**XK3100****SYSTEM BLOCK DIAGRAM****BOARD DESCRIPTION:****Safety/Battery Monitor:**

- X3100V8 (One on-board, one additional sample)  
With the following features:
  - Selectable over-voltage, under-voltage, and over-current protection circuitry
  - 4K bits EEPROM memory
  - Analog MUX, with output, to externally monitor cell voltages and pack current
  - Current sense amplifier with x10, x25, x80, x160 selectable gain.
  - 5V +/- 0.5% voltage regulator,
  - Automatic and manual control of charge/discharge FETs
  - Manual control of cell voltage balancing FETs.

**Microcontroller:**

- Mitsubishi M37516M4  
With the following features:
  - Memory
    - ROM: 16 Kilobytes. Preprogrammed with board firmware.
    - RAM: 512 bytes
  - A-D Converter:
    - Successive Approximation architecture.
    - 10-bit resolution, +/- 1 LSB.
    - Eight analog channels available.

- 12.5 $\mu$ s typical conversion time for ADC.
- Timers:
  - Four 8-bit and one 16-bit watchdog timer available.
  - All are multi-purpose: designer can choose from timer, event count, pulse output, or pulse period measurement mode.
- Serial I/O:
  - SPI port.
  - I<sup>2</sup>C port:
- Low-power Dissipation:
  - Multiple speed modes possible to conserve battery power.
  - Less than 1 $\mu$ A in lowest power mode
- Development tools readily available.

**Emulator Support:**

The XK3100 board provides a socket that accepts the Mitsubishi development tools and a single switch that selects the on-board microcontroller or the emulation system. This facilitates the development of custom routines, such as SMBus support, cell balancing or fuel gauging.

**Interface between PC and development board**

- Parallel interface from PC to XK3100 board. Converts to I<sup>2</sup>C on board to connect to the microcontroller.

**XK3100****SOFTWARE DESCRIPTION**

- Windows 95/98 based software provides:
  - Menu driven interface.
  - Full time display that shows battery information on a periodic basis. Information shown includes voltage on each cell, Rsense voltage (both directions), computed current, Computed B+ voltage, temperature, control and configuration bits and pack status. There are 6 sampling rates from 1 second to 120 seconds and samples may be recorded in a file. This provides the ability to automatically monitor a test setup of battery performance over a long period of time.

- Tabular selection of screens for setting the programmable characteristics of the X3100. This includes setting over-voltage, under-voltage and over-current thresholds, selecting sleep and power down modes, direct control of the charge/discharge FETs, direct control of the cell balancing FETs, and specifying the gain of the cell current amplifier.
- A tabular screen selection also allows the reading and writing of the EEPROM array.

**Graphical User Interface**

The following diagram shows a sample screen from the XK3100 development kit.

The screenshot displays the software interface for the XK3100 development kit, showing the 'Control' tab. The interface is divided into several sections:

- Configuration:** Includes tabs for Configuration, Control (selected), and EEPROM.
- Fet Control:**
  - Charge FET:  OFF,  ON
  - Discharge FET:  OFF,  ON
- Cell Voltage Balance FET Control:**
  - CB1:  OFF,  ON
  - CB2:  OFF,  ON
  - CB3:  OFF,  ON
  - CB4:  OFF,  ON
- Mode:**
  - Sleep Mode(everything off)
  - Monitor Mode(Analog MUX monitoring enabled)
  - Normal Mode(Protection Only)
- Current Sense Amp. Gain:** \*10 (dropdown menu)
- Buttons:** Default, Apply, Cancel

The **Monitor** screen (right side) displays the following data:

- Monitor:**
  - B+: 0.00 V
  - Vcell1: 0.00 V
  - Vcell2: 0.00 V
  - Vcell3: 0.00 V
  - Vcell4: 0.00 V
  - Vcs1: 0.00 V
  - Vcs2: 0.00 V
  - Ipack: 0.000 A
  - TH: 0.00 V
- Register:**

	HIGH	LOW
STATUS		00000000
CONFIG	00000000	10000000
CONTROL	00000000	00000000
- Status:**
  - Cell Voltage: NORMAL
  - Pack Current: NORMAL
  - Operating Mode: **MONITOR**
  - EEPROM Write In: READY
- Buttons:** Monitor, Start

The **Data Log** section at the bottom includes buttons for Start, Stop, and Save, along with a Data Log Rate dropdown set to 1 S.

# XK3100

## BOARD DIAGRAM

