

NEW

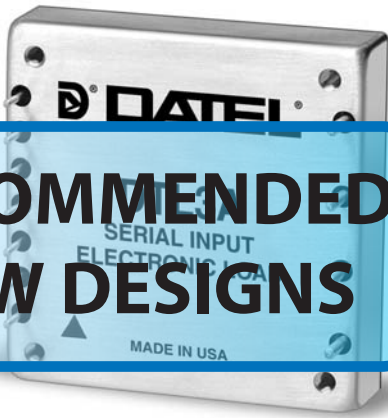

NOT RECOMMENDED FOR NEW DESIGNS



DTL Series DTL3A Model

Digitally Programmable, 2A/200V 100 Watt, Electronic Loads

Features

- 12-bit, optically isolated (500Vdc), CMOS/TTL-compatible serial input
- 0-2 Amp output in 500µA increments
- Output voltage to 200 Volts
- Output power to 100 Watts
- 10MΩ minimum output impedance
- ±500µA offset error; ±0.1% gain error
- 100µsec full-scale step response
- Update rates to 20kHz
- Operate in parallel for higher power
- Miniature, 2" x 2" metal package

Applications

- Static/dynamic power-supply burn-in
- Power-supply test and characterization
- Battery capacity testing
- Current-source testing
- Capacitor discharge testing
- Real-time load simulation

DATEL's new DTL3A is a digitally controlled, optically isolated, serial-input electronic load that offers high compliance voltage and unprecedented control over low-level currents. The DTL3A is essentially a computer controlled current source that sinks currents from 0 to 2 Amps, at loading voltages from 2.5 to 200 Volts, up to a maximum power of 100 Watts. The DTL3A accepts a serialized, 12-bit, CMOS/TTL digital input word, optically isolates (500Vdc) the data, latches it, and presents it to an on-board, 12-bit, digital-to-analog (D/A) converter. The D/A output drives a near-ideal (10MΩ output impedance), voltage-controlled current source.

One LSB (least significant bit) of the D/A corresponds to a mere 500µA (0.025% of 2A) of load current. Combined with the DTL3A's ±500µA max. offset error and ±0.1% max. gain error, this precise digital control gives users extraordinary command over the generation of low-level load currents. A 100mA current, for example, is guaranteed to have ±1mA accuracy over all specified load-voltage conditions.

The DTL3A has impressive speed performance. Digital update rates to 20kHz are possible, and settling time for a full 2A step is 100µsec. The unit is housed in a thermally efficient, 2" x 2" x 0.5" metal package that has an aluminum baseplate with through-hole spacers for easy pcb mounting and/or external heat-sink attachment.

The DTL-3A has an output compliance-voltage requirement 2.5 to 200V. Should the output/load voltage drop below the 2.5V minimum required for proper biasing, an internal monitoring circuit activates the DTL3A's output Fault line. See DATEL's DTL2A-LC for compliance voltages as low as 0.6V.

DATEL's electronic loads, controller boards and companion software are outstanding building-block components for power-supply (AC/DC and DC/DC) and power-component (diodes, FET's, etc.) burn-in and test systems. They are an extremely reliable, cost-effective solution that enables you to quickly configure flexible, impressively accurate systems.

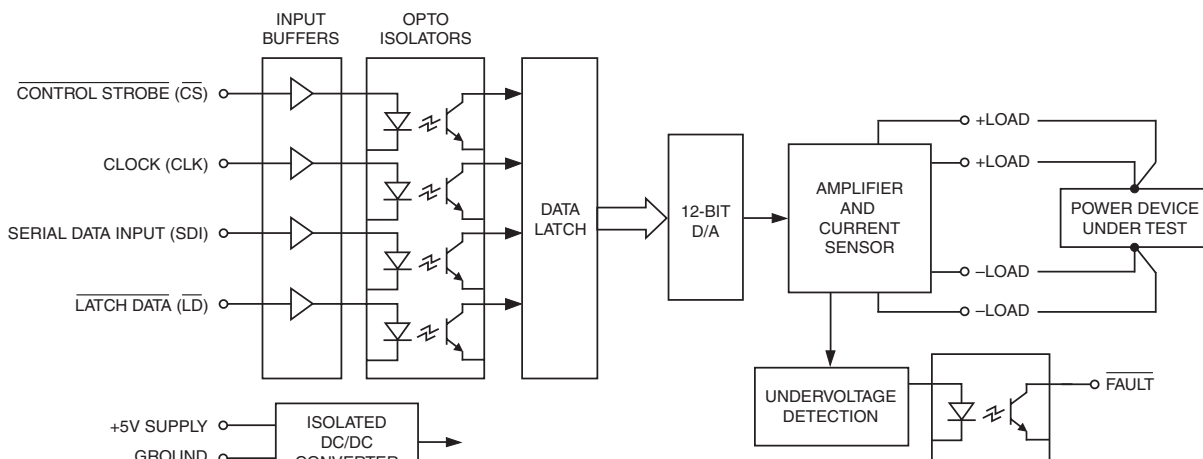
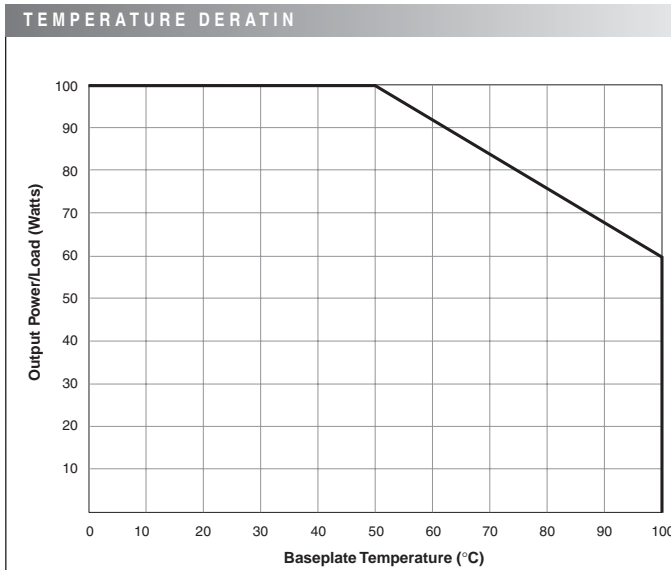
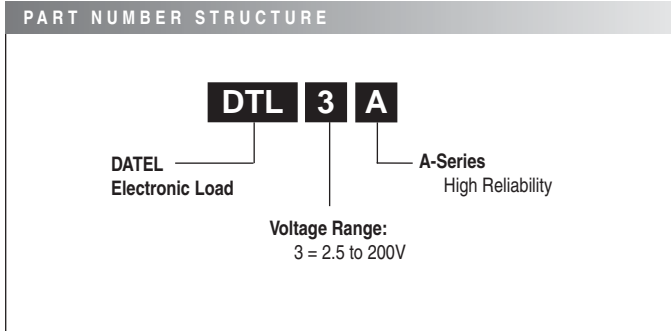

Figure 1. Simplified Schematic

Performance Specifications and Ordering Guide ①

Model	Input		Output				Package (Case, Pinout)
	Resolution (Bits)	Logic Compatibility	Current (Amps)	Resolution (mA) ②	Compliance Voltage (Volts) ③	Power (Watts)	
DTL3A	12	CMOS/TTL ④	0-2	0.5	2.5-200	0-100	C24, P31

- ① Typical at TA = +25°C with nominal +5V supply voltage unless noted.
- ② The smallest increment/decrement in output current is defined by one LSB (least significant bit) of the 12-bit digital input word. One LSB is equal to full scale (FS) divided by 4096 which corresponds to 0.0244% of 2A or 488µA.
- ③ For proper operation, the unit's output/load voltage must remain within this range. Voltages greater than the listed maximum can damage the device. Voltages less than the minimum provide insufficient bias for the output stage and will result in unpredictable or no operation. See Output Compliance Voltage and the Fault Line for details.
- ④ See Performance/Functional Specifications for details.



The horizontal axis of the above chart references the temperature of the DTL3A's aluminum baseplate. The device can continually dissipate up to 100 Watts if the baseplate is maintained at or below +50°C. At +25°C ambient temperature, with no heat sink or supplemental air flow, the DTL3A can reliably dissipate a continuous 10 Watts.

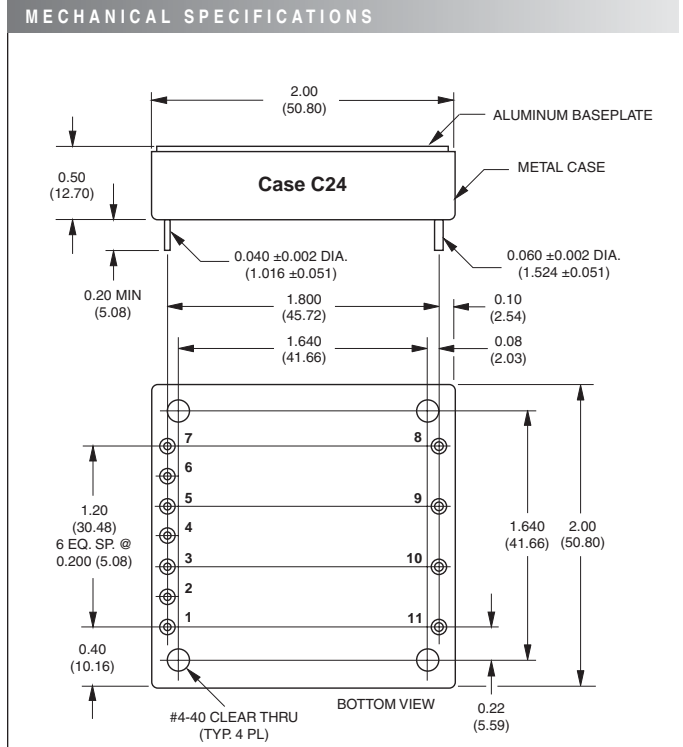

I/O Connections

Pin	Function P31	Pin	Function P31
1	Fault	7	Control Strobe (CS)
2	Ground	8	-Load
3	+5 Volt Supply	9	-Load
4	Latch Data (LD)	10	+Load
5	Serial Data In (SDI)	11	+Load
6	Clock (CLK)		

Contact DATEL for Heat Sink information.

Performance/Functional Specifications

Typical @ T_A = +25°C with nominal +5V supply voltage, unless noted.

Digital Inputs/Outputs	
Logic Compatibility (Pins 1, 4-7)	CMOS/TTL
Input Logic Levels:	
Logic "1"	+2 Volts, minimum
Logic "0"	+0.8 Volts, maximum
Input Logic Loading:	
Logic "1" (I _{IH} @ V _{IH} = 5 Volts)	20µA, maximum
Logic "0" (I _{IL} @ V _{IL} = 0 Volts)	-0.6mA, maximum
Output Logic Levels:	
Logic "1" (@ 150µA)	+3.5 Volts, minimum
Logic "0" (@ 1.6mA)	+0.4 Volts, maximum
Timing	See Timing Diagram
Output	
Current:	
Range	0-2 Amps
Resolution ①	0.024%FS (488µA)
Accuracy ⑥	±1%, maximum
Voltage Range ②	2.5-200 Volts
Power Range	0-100 Watts
Impedance	10MΩ, minimum
Offset Error ③	±0.5mA, maximum
Gain Error	±0.1%, maximum
Isolation Voltage:	
Digital Inputs/Output to ±Load	500Vdc, minimum
Any Pin to Case	500Vdc, minimum
Isolation Resistance	100MΩ, minimum
Dynamic Performance	
Output Slew Rate	±10A/µsec, minimum
Output Settling Time ④	100µsec
Digital Input Update Rate	to 20kHz
Power Requirements	
Power Supply Range (+V _{CC} , Pin 3)	+4.75-5.25 Volts (+5V nominal)
Power Supply Current	110mA typ., 150mA max.
Environmental	
Operating Temperature ⑤	-40 to +100°C (Case)
Storage Temperature	-40 to +125°C (Ambient)
Humidity (Non-condensing)	to 95%
Altitude Above Sea Level	10,000 feet
Physical	
Dimensions	2" x 2" x 0.5" (51 x 51 x 12.7mm)
Shielding	6-sided (Connected to pin 2)
Case Material	Tin-plated steel shell with aluminum baseplate
Pin Material	Brass, solder coated
Mounting Holes	Through-hole spacers, #4-40 clearance
Weight	1.9 ounces (54 grams)

- ① The smallest increment/decrement in output current is defined by one LSB (least significant bit) of the 12-bit digital input word. One LSB is equal to full scale (FS) divided by 4096 which corresponds to 0.0244% of 2A or 488µA.
- ② For proper operation, the unit's output/load voltage must remain within this range. Voltages greater than the listed maximum can damage the device. Voltages less than the minimum provide insufficient bias for the output stage and will result in unpredictable or no operation. See Output Compliance Voltage and the Fault Line for details.
- ③ Offset error is defined as the current sunk/sourced by the DTL3A's output, under any output voltage conditions, when the digital input word is all "0's."
- ④ Full scale step (2 Amps) settling to within ±0.5mA of its final value.
- ⑤ See Temperature Derating.
- ⑥ Applies over all specified ranges/combinations of load voltage/current, operating temperature, and V_{CC}.

Absolute Maximum Ratings	
Power Supply Voltage (+V _{CC} , Pin 3)	-0.5 to +5.5 Volts
Digital Input Voltage (Pins 4-7)	-0.5 to +5.5 Volts
Output Reverse-Polarity Protection	No protection
Output Overvoltage Protection	No protection
Output Undervoltage Protection	Yes (See Fault Line)
Case Temperature	+105°C
Storage Temperature (Ambient)	-40 to +125°C
Lead Temperature (Soldering, 10 sec.)	+300°C
These are stress ratings. Exposure of devices to any of these conditions may adversely affect long-term reliability. Proper operation under conditions other than those listed in the Performance/Functional Specifications Table is not implied.	

TECHNICAL NOTES

Overview

The DTL3A is a digitally programmable, CMOS/TTL-compatible, serial-input current sink. It's output/load current range is 0 to 2 Amps (in 488µA increments), over a compliance voltage range of 2.5 to 200 Volts and an output/load power range of 0 to 100 Watts. The device's digital I/O coding is straight binary (see table below). A digital input of all "0's" forces a load current of 0 Amps. A digital input of all "1's" forces a load current of 1.9995 Amps.

In a typical power-supply test or burn-in application, the output pins of the device under test (DUT) are connected to the DTL3A's +Load (pins 10 and 11) and -Load (pins 8 and 9) outputs. The DTL3A's operation is controlled by its four digital input lines (Serial Data In, Clock, Latch Data and Control Strobe).

Serial Input Data Word			Load Current (Amps)
MSB	LSB		DTL3A
1111	1111	1111	1.9995
1100	0000	0000	1.5000
1000	0000	0000	1.0000
0111	1111	1111	0.9995
0100	0000	0000	0.5000
0010	0000	0000	0.2500
0000	0000	0001	0.0005
0000	0000	0000	0.0000

Mapping of the Serial-Input Data to Load Current

Initialization

Preparing the DTL3A to accept new digital data is accomplished by applying logic "1's" to $\overline{\text{Control Strobe}}$ ($\overline{\text{CS}}$, pin 7), $\overline{\text{Latch Data}}$ ($\overline{\text{LD}}$, pin 4) and Clock (CLK, pin 6) with all signals present and stable for a minimum of 1 μsec . During this interval, it does not matter whether or not data is present on the Serial Data In (SDI, pin 5) line.

Serial Data

Following initialization, the 12-bit digital word representing the desired output current is applied to the SDI pin. The serial data should appear starting with the most significant bit (MSB, bit 1, D11) and ending with the least significant bit (LSB, bit 12, D0). With each data bit present and stable on the SDI line, the CLK must be toggled through a low-to-high transition to register that bit. Twelve rising clock edges, at rates up to 500kHz, are required to clock all 12 digital bits into the DTL3A's input register.

Latching Data and Presenting It to the D/A

After loading the LSB, the serial data word is latched by bringing the $\overline{\text{Control Strobe}}$ (pin 7) high and then toggling the $\overline{\text{Latch Data}}$ pin (pin 4) through a high-low-high sequence. Approximately 100 μsec later, the output current will settle to its final desired value.

Software: C Language

The following steps describe a typical timing sequence when using the DTL3A's 4 digital inputs and a programming language such as C. Using 4 bits of a typical 8-bit port, assign BIT_0 to the $\overline{\text{Control Strobe}}$ ($\overline{\text{CS}}$, pin 7), BIT_1 to $\overline{\text{Latch Data}}$ ($\overline{\text{LD}}$, pin 4), BIT_2 to Serial Data In (SDI, pin 5), and BIT_3 to the Clock (CLK, pin 6).

1. Initialize with $\overline{\text{Control Strobe}}$, $\overline{\text{Latch Data}}$, and Clock high:
BIT_0 = 1, BIT_1 = 1, BIT_2 = X (don't care), BIT_3 = 1
2. Bring the $\overline{\text{Control Strobe}}$ low.
BIT_0 = 0
3. Apply the MSB (D11) of the serial data word to Serial Data In.
BIT_2 = 0 or 1
4. Toggle the Clock high-low-high.
BIT_3 = 1 to 0 to 1
5. Apply D10 of the serial data word to Serial Data In.
BIT_2 = 0 or 1
6. Toggle the Clock high-low-high.
BIT_3 = 1 to 0 to 1
7. Repeat the process for remaining data bits D9 through D0.
8. Drive the $\overline{\text{Control Strobe}}$ high.
BIT_0 = 1
9. Toggle the $\overline{\text{Latch Data}}$ input high-low-high.
BIT_1 = 1 to 0 to 1.

Output Compliance Voltage and the Fault Line

For proper operation, the DTL3A's output/load voltage must always be between 2.5 and 200 Volts. The device cannot be used to directly load low-voltage, e.g. 1.8V or 2.5V, power components or to simulate a true short circuit (0 Volts). Voltages greater than 200V can damage the device. Voltages <2.5V will result in insufficient biasing of the output current source and consequently unpredictable or no operation. Accordingly, we have installed an internal output/load-voltage monitoring circuit. If the output/load voltage drops below 2.5V and the DTL3A's output is at risk of becoming disabled, the Fault line activates.

The Fault line is an optically isolated, active-low function with an open-collector output (internal 10k Ω pull-up resistor to +5V). Under normal conditions, its output is high (logic "1"). Under fault conditions ($V_{\text{OUT}} < 2.5\text{V}$), its output drops to a logic "0." There is no output/load-voltage monitoring circuit for voltages greater than 200V, and operation above 200V can damage the device.

An "offset supply" can be inserted between the DTL3A's -Load output (pins 8 and 9) and the power device under test (DUT) to "translate" the DTL3A's 197.5V output/load voltage range. The offset supply must have adequate current capabilities and be connected with the polarities indicated in Figure 2 below. Under no circumstances should the voltage across the DTL3A's output be allowed to experience a polarity reversal.

If a 5V/20A offset supply is inserted as shown, the range of DUT voltages will be -2.5 to +195 Volts. Such a configuration can be used for true short-circuit testing. A mechanical relay can be used to short the outputs of the DUT while the offset supply ensures the DTL3A always sees at least 5 Volts across its outputs.

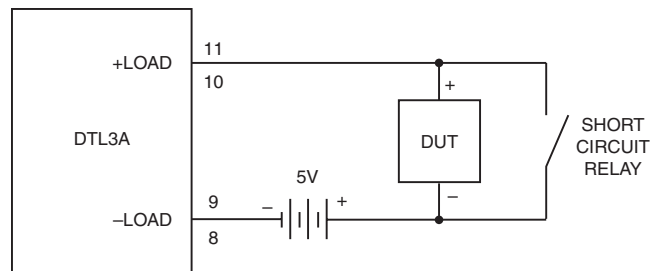

Figure 2. An "Offset Supply" Enables True Short-Circuit Testing

Thermal Considerations

The DTL3A can reliably handle 100W loads if its case temperature is maintained at or below +50°C. With no heat sinking or auxiliary cooling, the device can only handle loads up to 10 Watts. Please refer to the Temperature Derating Curve for additional information. DATEL's Electronic Load Applications Engineers can assist you in developing heat-sink solutions for your higher-power DTL3A applications. Please contact us for details.

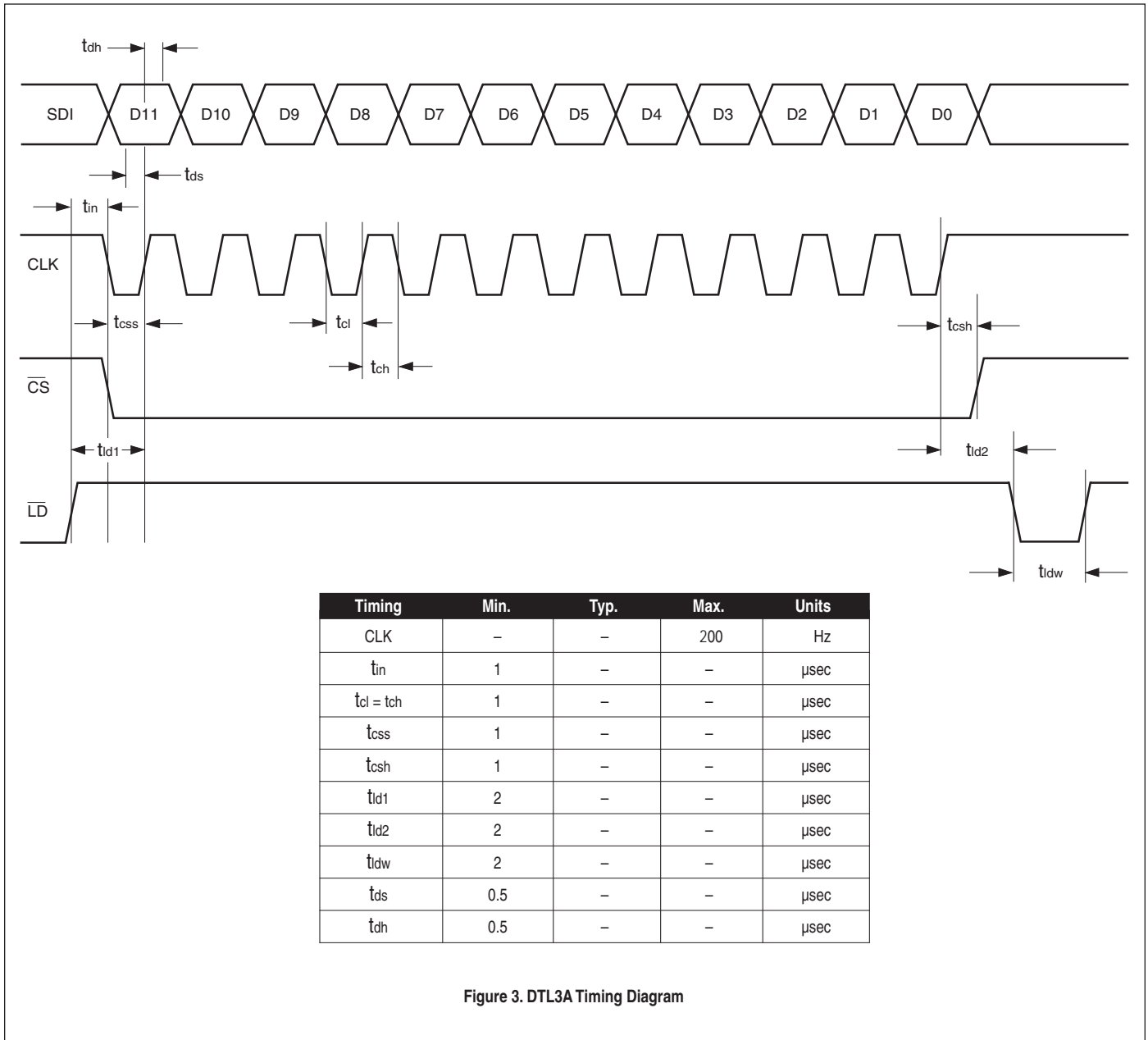

Figure 3. DTL3A Timing Diagram