

WISMO Quik Q2686

Process Customer Guidelines

www.DataSheet4U.com

Reference : **WM_PRJ_Q2686_PTS_004**
Revision : **003**
Date : **08th February 2006**



Document Information

Revision	Date	History of the evolution	
001	02/09/05	Creation	
002	24/11/05	Move from Q2686F to Q2686H	
003	08/02/06	Add of IMP connector	

Contents

Document Information	2
Contents	3
Caution	5
Trademarks	5
Overview	6
1. Storage condition	7
2. Products packaging and labeling	7
2.1 Packaging Elements	7
2.1.1 Packaging "pizza box"	7
2.1.2 Outer Package	8
2.1.3 EUR pallet	8
2.1.4 Strap	9
2.1.5 Shrink plastic	9
2.2 Summary of recyclable elements	9
2.3 Product label specifications	10
2.3.1 Wismo Q2686 labeling layout	10
2.3.2 Inner packaging	12
2.3.3 Outer packaging	13
3. Caution	14
3.1 Handling	14
4. Assembly process	15
4.1 General	15
4.2 Lead-free process	15
4.3 RF connection	16
4.3.1 UFL/SMA connector	16
4.3.2 Coaxial cable on the back side of the Wireless CPU	17
4.3.3 IMP connector	19
4.4 100 leads connector process insertion	20
4.5 Soldering of the legs	21
4.5.1 Recommended equipment	21
4.5.2 Hand soldering	22
4.6 Acceptance criteria	23

5. Rework and Wireless CPU exchange processes 24

5.1 General.....24

5.2 Procedure.....24

 5.2.1 Equipment recommended.....24

 5.2.2 Process.....24

5.3 Acceptance criteria25

5.4 Solder new Wireless CPU25

APPENDIXES 26

www.DataSheet4U.com

Caution

Information furnished herein by Wavecom is accurate and reliable. However no responsibility is assumed for its use.

General information about Wavecom and its range of products is available at the following internet address: <http://www.wavecom.com>

www.DataSheet4U.com

Trademarks

Some mentioned products are registered trademarks of their respective companies.

Overview

This document gives guidelines for the industrial assembly of a WISMO Quik Q2686 Wireless CPU on an application.

The product concerned is the following:

- Q2686: EGSM/GPRS Class 10 850/900/1800/1900 MHz with 32 Mb of Flash memory and 8 Mb of PSRAM (32/8)

1. Storage condition

Wireless CPU can be stored in the following condition: -40°C to +85°C during 1 year.

2. Products packaging and labeling

www.DataSheet4U.com

WAVECOM WISMO QUIK Q2686 are shipped in a box (inner package) which contain 100 products (5 lines of 20 products).

2.1 Packaging Elements

2.1.1 Packaging "pizza box"

Specifications :

Material : Collective ESD Box type "pizza box"

Type : FEFCO 0427

Dimension : 305 * 218 * 50

Capacity : 100 WISMO QUIK

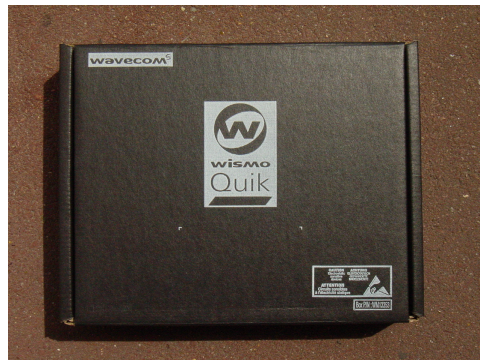

This packaging is stamped with WISMO logo and with RESY specification and with a warning label regarding static sensitive device.

2.1.2 Outer Package

Specification :

Material : Double wall (or double-face) corrugated brown carton (three sheets of linerboard with two mediums in between)

Type : FEFCO 0201

Dimension : 440 * 310 * 154

Capacity : 6 Pizza boxes (2x3)

This packaging is stamped with RESY specification.

The dimension is defined to be filled with boxes without any empty space

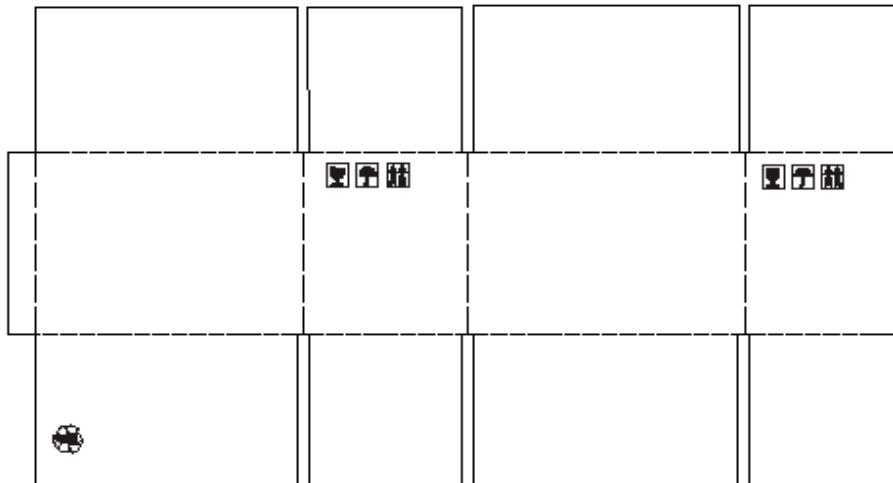

Figure 3 Design of collective packaging

2.1.3 EUR pallet

Specification:

Weight: 22 kg

Dimensions: 1200mm x 800mm x 150 mm

Capacity: From 3 to 12 cartons

Weight Loaded: Up to 350 kg

2.1.4 Strap

Specification :

Material: polypropylene.

width : Minimum 08 mm.

2.1.5 Shrink plastic

Specification :

Material: polyethylene.

Type : shrunk plastic bag.

Dimension : at least 20 micron

2.2 Summary of recyclable elements

Packaging Elements	Recyclable
Inner package	Yes
Outer package	Yes

2.3 Product label specifications

This specification is given for information only. WAVECOM may, at any time and without notice, make changes to the label.

www.DataSheet4U.com

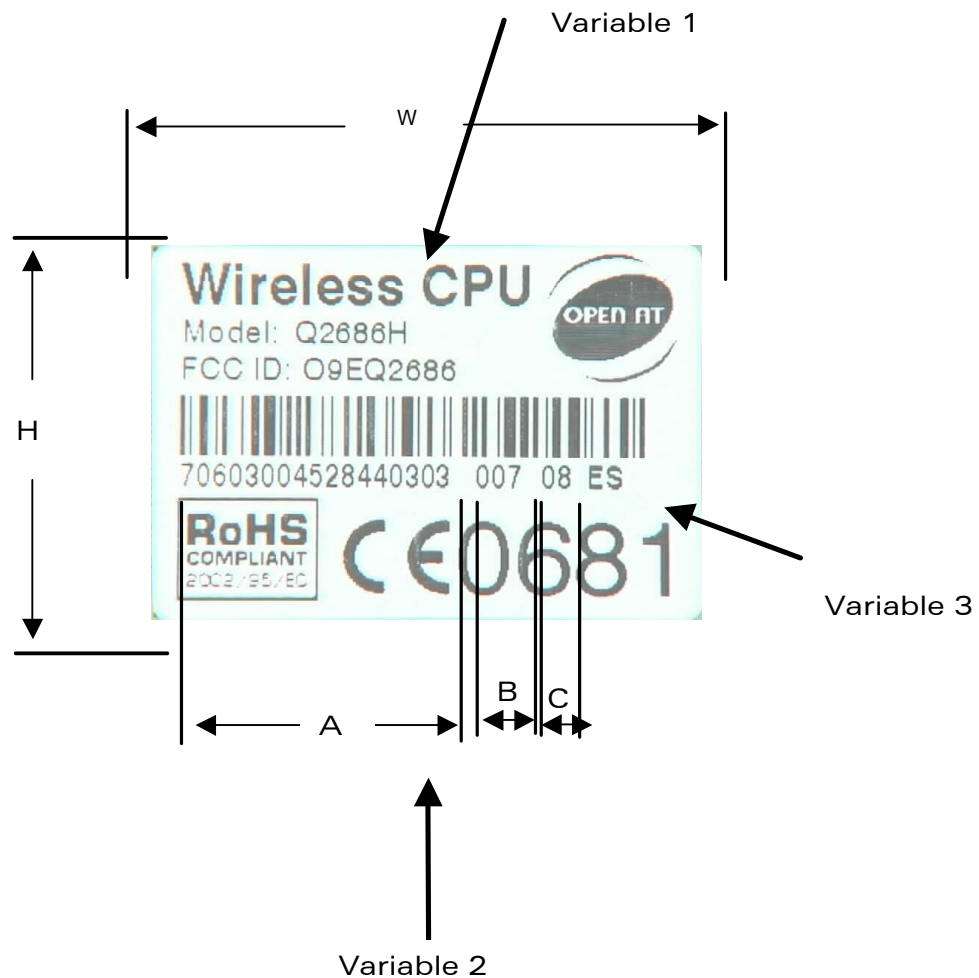

Wismo Q2686 labeling layout

W: 29mm (max)

H: 20mm (max)

Material : Polyester

Notes: The maximum temperature supported by the label is 100°C

www.DataSheet4U.com

Variable 1

Product reference

Variable 2

Tracking number specification

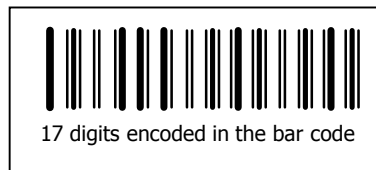

A

	Product type	Unit of the year	Week	Chronological number	Numeric test bench ID	PCB version + part-list	Retrofit version
Format	2 digits 0-99	1 digit 0-9	2 digits 1-53	5 digits 0-99999	2 digits 0-32	3 digits (xxx) 0-999	2 digits (xx) 0-99
Ex.	54 for Q2406-C	3 for y.2003	01	00170	01	401 for hw version V401	01 (V401, no retrofit)

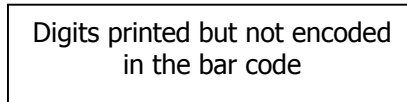

B

C

	RF test bench ID
Format	3 digits 0-xxx
Ex.	136

Production site ID
Blank or 2 digits 0-99
Blank for WM internal

Variable 3

ES (Engineering sample)

PP (Pre-Production)

"" (mass production)

2.3.1 Inner packaging

www.DataSheet4U.com



28xxxxxxxxxx301

2460000320	2460002720	2460007821	2460021721	2460031120
2460036720	2460074821	2460106221	2460116321	2460128721
2460131821	2460133320	2460135320	2460135420	2460135821
2460140121	2460141220	2460149921	2460152721	2460152821
2460153020	2460162121	2460205921	2470006970	2470007070
2470007270	2470007370	2470007470	2470007570	2470007670
2470008070	2470008170	2470008870	2470009270	2470009621
2470013470	2470015070	2470015170	2470015270	2470015370
2470015770	2480000020	2480000420	2480000520	2480000720
2480001020	2480001320	2480001421	2480001720	2480001721
2480002521	2480004720	2480007220	2480008220	2480009621
2480010820	2480010920	2480010921	2480011020	2480011021
2480011120	2480011121	2480011220	2480011221	2480011320
2480011321	2480011420	2480011421	2480011520	2480011521
2480011620	2480011621	2480011720	2480011721	2480011820
2480011821	2480011920	2480011921	2480012020	2480012021
2480012120	2480012121	2480013320	2480013421	2480013520
2480013621	2480013820	2480013821	2480013920	2480014020
2480014021	2480014221	2500013270	2500013370	2500013470
2500013870	2500013870	2500013970	2500015470	2500015770

List of serial numbers of products

Complete marketing reference +
custom reference + hardware version

Internal reference (5 digits)
Software code (4 digits)
Software version
Options (32 characters max.)

Quantity of products in the box

Box serial number on 14 digits :
MM : manufacturing plant
TTT : product type
Y : last figure in the year in progress
WW : week in progress
PP : packaging bench number
BBBB : chronological number in the week

Q2686H

Internal Ref: WM13969

Software code:DR03

Software version: 420412im12a.07

Options: gd,115200,Annul Echo

Quantity: 100

Sealed and packaged (dd/mm/yyyy H24) : 07/01/2003 08:08:19



04028249010029

2.3.2 Outer packaging

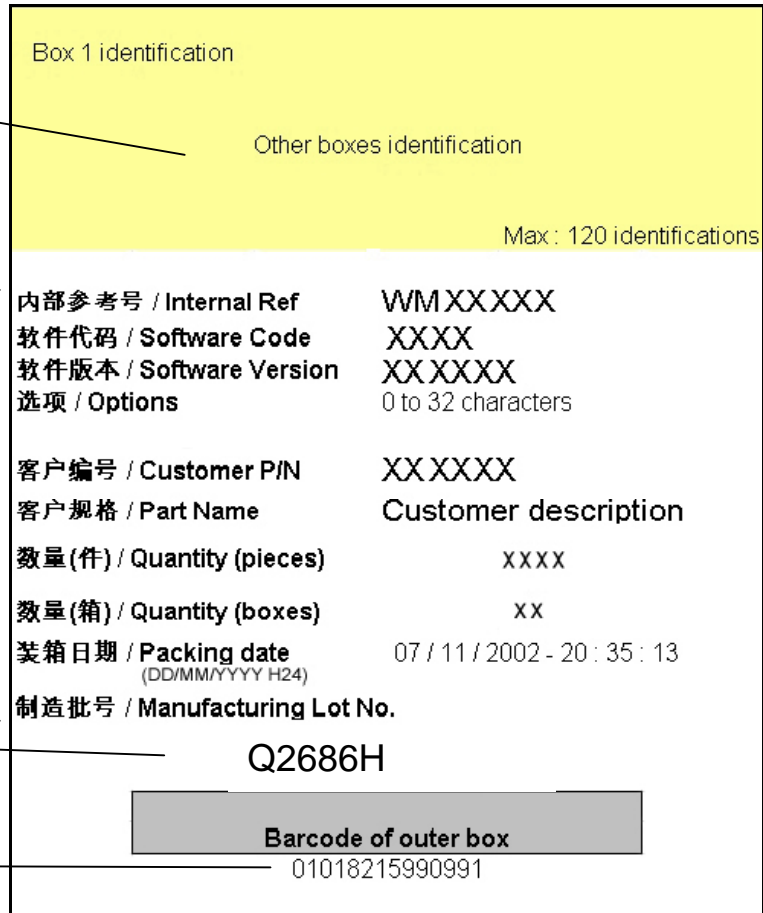

Complete **serial numbers of boxes** of lower level logistic units (manufacturing boxes for outer boxes and outer boxes for pallets)

Information on products and boxes inside the outer box (or pallet)

Complete marketing reference + custom reference + hardware version

Outer box serial number on 14 digits :
MM : manufacturing plant
TTT : product type
Y : last figure in the year in progress
WW : week in progress
PP : packaging bench number
BBBB : chronological number in the week

www.DataSheet4U.com

3. Caution

3.1 Handling

WISMO Quik Q2686 are ESD sensitive (Voltage < 1kV)

ESD	
Ground Equipments (tables and shelves)	✓
No plastic bags	✓
ESD Chairs	✓
Avoid any non-useful material	✓
Wear Cotton blouse (avoid any synthetic blouse)	✓
Wear ESD shoes or heel stapes	✓
When seated, wear wrist strap	✓
BEFORE entering an ESD area, check the discharge and if necessary evacuate charge via the tester	✓
HUMIDITY	
Standard ranges for humidity are between 30 and 70% RH	✓
TEMPERATURE	
Standard ranges for Temperature are between 5 and 45°C	✓
HANDLING	
Wear gloves	✓
Handle Wismo Quik based on IPC A610 reference chapter 3	✓
SOLDERING	
Soldering reflow is forbidden	✓

4. Assembly process

This section gives recommendations for the industrial assembly of the Wireless CPU on the application.

4.1 General

- Gloves must be worn when handling the CPU
- No cleaning of the CPU is allowed
- No warm air shall be blown on the CPU
- Be careful not to damage the label of the CPU (warranty condition)

4.2 Lead-free process

According to the directive 2002/95/CE, Wavecom banish the following hazardous substances: mercury (Hg), lead (Pb), cadmium (Cd), hexavalent chromium (Cr+6), polybrominated diphenyl ether (PBDE), polybrominated biphenyl (PBB). Therefore, Wavecom Wireless CPU are :

- with lead-free terminals

and - with lead-free inner materials (components and solder paste)

Therefore, the customer can have a lead-free customer application by using lead-free materials (lead-free SMD solder paste, lead-free components and lead-free solder wire...).

But the Wireless CPU is also mountable with a leaded process.

But in this case, we recommend to use lead-free solder wires to guarantee that if Wavecom CPU is removed, the CPU is still lead-free.

4.3 RF connection

There are three possibilities for RF connection

- via UFL/SMA cable
- via coaxial cable
- via IMP connector

www.DataSheet4U.com 4.3.1 UFL/SMA connector

The antenna can be connected to the Wireless CPU through the UFL connector present on the Wavecom CPU.

- Insert the plug in the receptacle

This step is done prior to the CPU mounting.

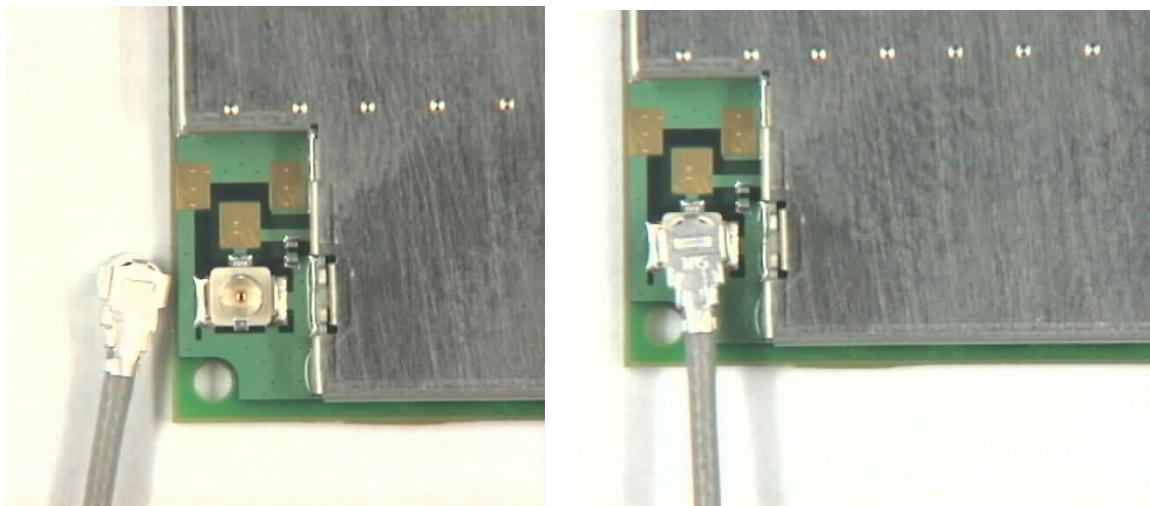

4.3.2 Coaxial cable on the back side of the Wireless CPU

The antenna can be connected to the CPU through a coaxial cable. The coaxial cable is connected to both the "RF pad" (or Round pad) and the "Ground pad".

It is recommended to use a RG178 coaxial cable:

- Static curvature radius: 10mm
- Dynamic curvature radius: 20mm

The cable must be soldered as described on the mechanical drawing in the following page:

- The shielding of the antenna cable must be soldered on the "Ground pad".
- The antenna cable core must be soldered only once positioned in line with the "RF pad" and "Ground Pad".
- It is highly recommended to use a template to adjust the antenna cable to the "RF pad" and "Ground Pad" before soldering

This step is done after the CPU mounting.

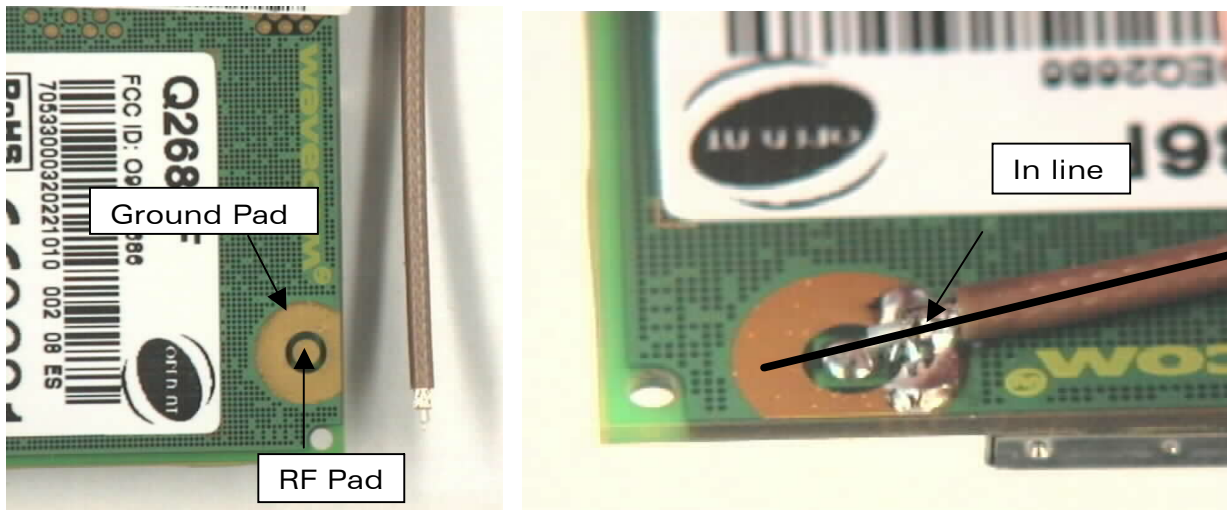

When soldering the antenna cable, the temperature of the iron must not exceed 350°C during 3s.

Note: the coaxial cable can be soldering in every direction. It can also be soldering on "the opposite direction". In that case it is necessary to make a curve (as describe on the figure bellow).

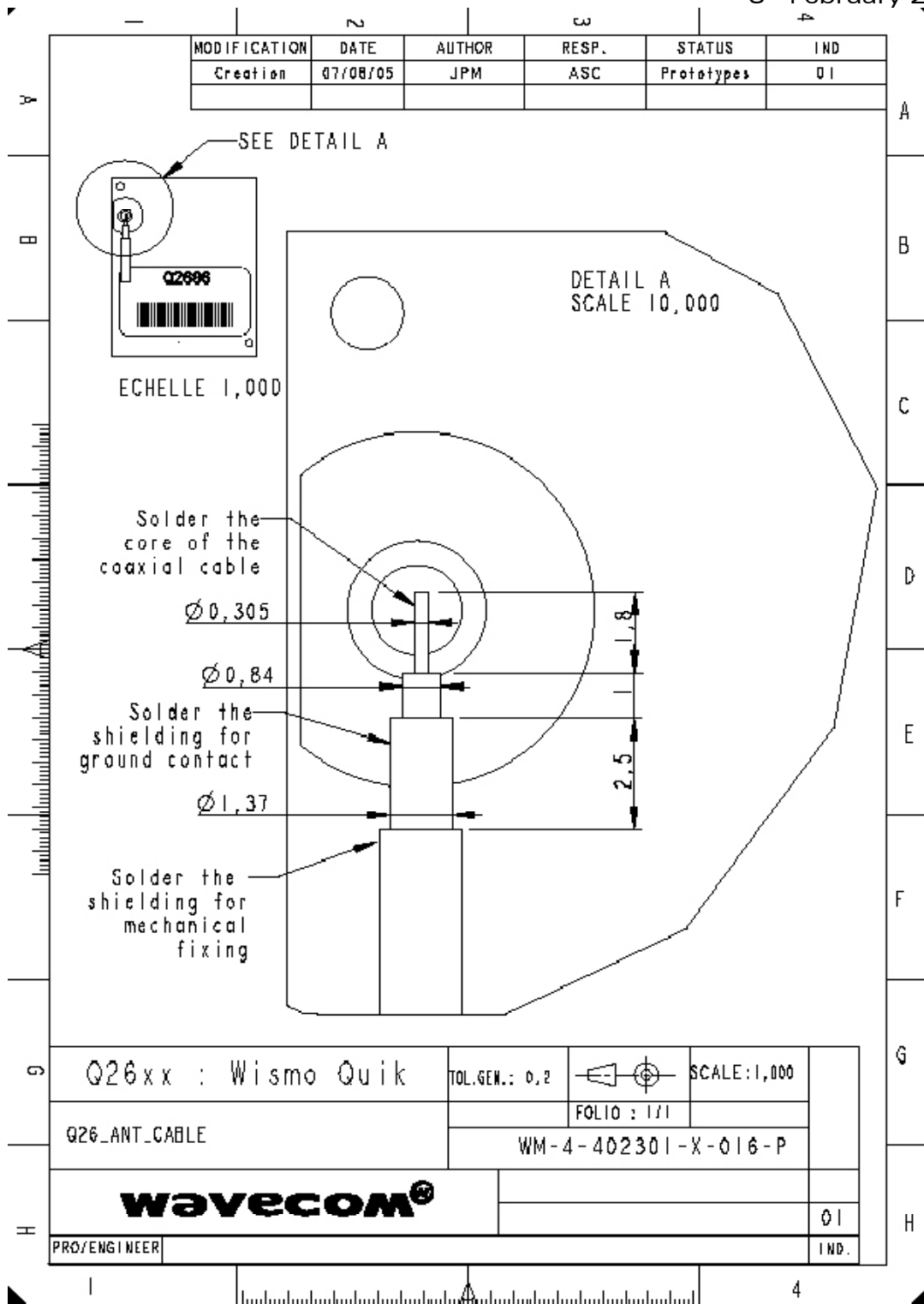

Figure 1: Antenna cable connection

The figure below describes the preparation and positioning of the cable.

4.3.3 IMP connector

The antenna can be connected to the Wireless CPU through an IMP connector that must be assembled on the customer board.

The description of the contact pad on Q2686 CPU is described in the appendix.

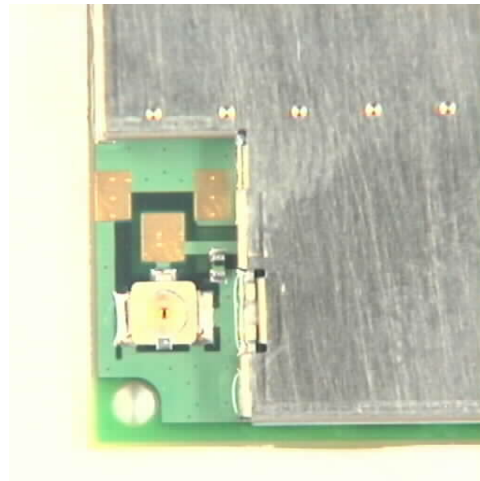

IMP connector is fragile. Special attention should be taken when handling the customer board in order to prevent any damage on it.

- No additional process step

Concerning mounting, assembly and handling of this component, please contact directly the supplier Radiall. Wavecom can not support the customer regarding the use of this connector.

4.4 100 leads connector process insertion

- Insert the Wireless CPU connector in the motherboard connector until you hear a click by inserting the shielding leads in the trough- holes.

The recommendations for these trough-holes are described in the appendix.

www.DataSheet4U.com

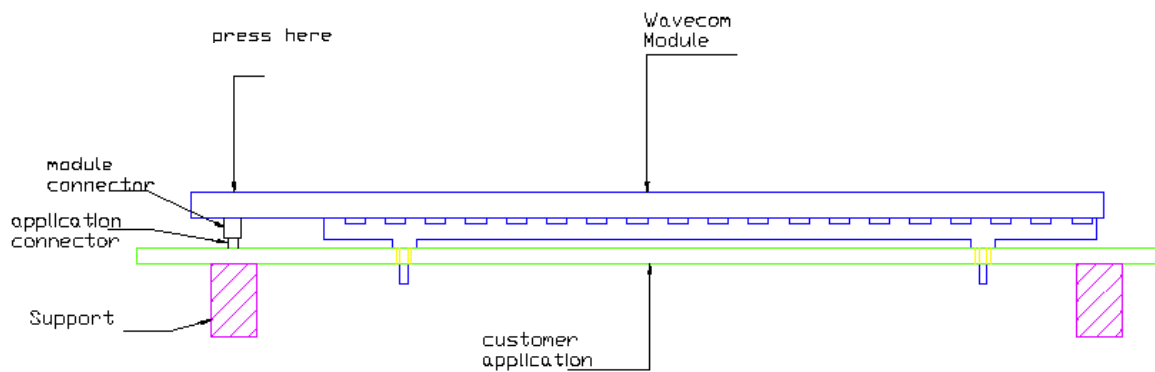

4.5 Soldering of the legs

The legs of the Wireless CPU shall be soldered according to the following instructions:

- The type and size of connection holes shall be chosen according to Wavecom recommendations (see layout requirement document and mechanical drawing in appendixes)
- The quality of the soldering, must be in accordance with the IPC-A-610 Rev-C chapter 6 Soldering.
 - Class 2: general case
 - Class 3: for automotive.
- The Figure bellow gives the CPU position before hand soldering, and caution for the Q2686.

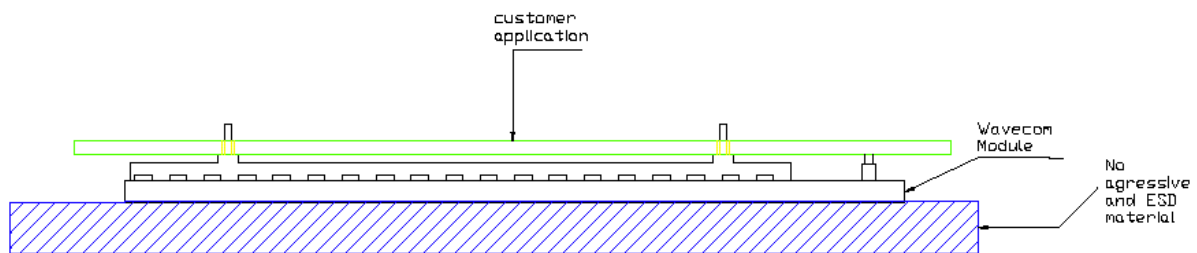

4.5.1 Recommended equipment

- Soldering iron WSD80 (Weller) or equivalent (T° max 385°)
 - -Solder Wire : Kester 245 Cored 58 (Sn96.5Ag3Cu0.5)
Or X39 60-40 (Multi-core) (SnPb or SnPbAg)
- Diameter = 0.32 mm
- Binocular type Mantis (Vision engineering) or equivalent
 - Soldering tip type: LT1 (reference: 5 44 401 99)

4.5.2 Hand soldering

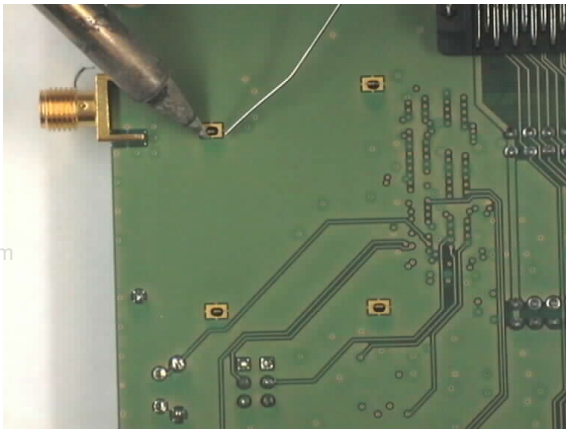

- Assemble the CPU in the customer application
- Characteristic click can be heard
- On the opposite side solder the 4 legs

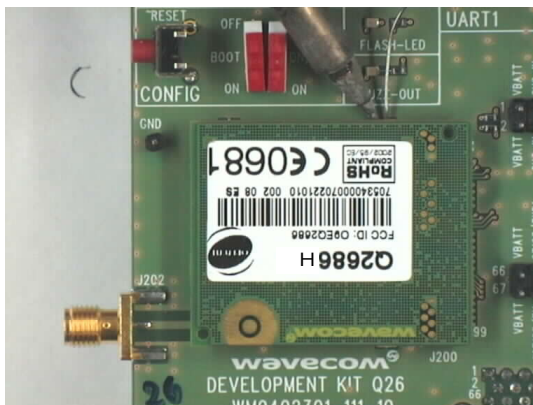

- Turn the application board and solder the 3 accessible legs on this side

- Check with binocular the quality of the solder on both sides

4.6 Acceptance criteria

- The soldering quality must be in accordance with the IPC-A-610 Rev-C chapter 6 Soldering.
- It must be no gap between Wavecom product and the customer application

www.DataSheet4U.com

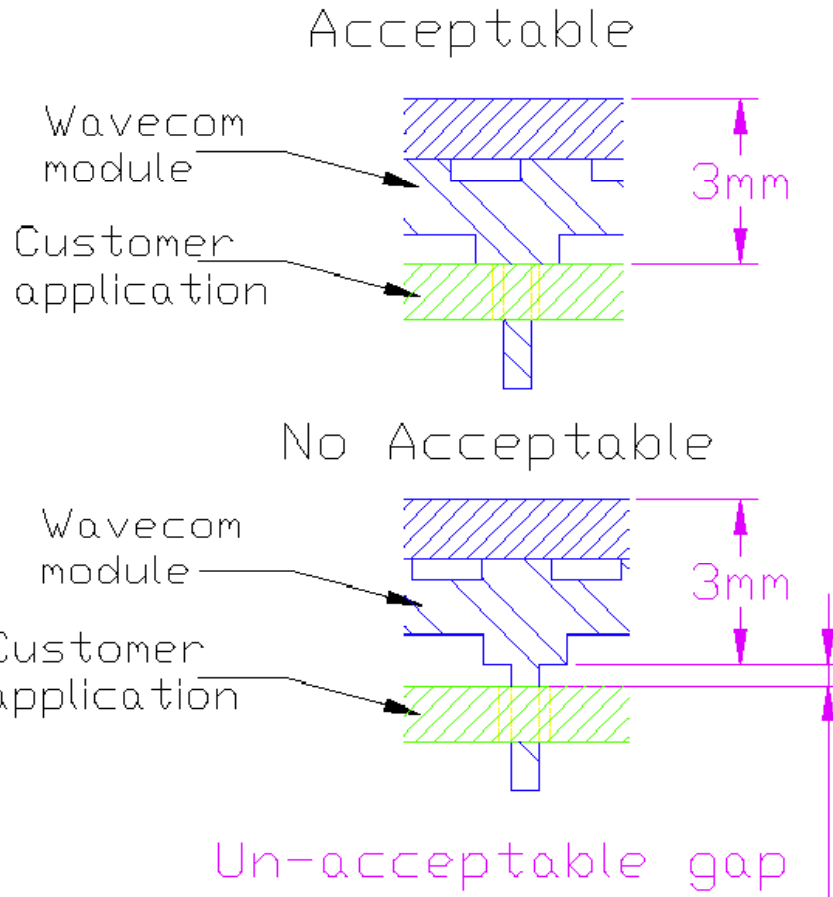

- Excessive solder must be avoid in order not to damage the PCBA or to prevent future repair.

Therefore, solder is only allowed at the lower-half of shielding belt (referring to Fig-1).



Half height of shielding belt

5. Rework and Wireless CPU exchange processes

5.1 General

The CPU can be changed 3 times.

The temperature of the iron must not exceed 385°C.

5.2 Procedure

5.2.1 Equipment recommended

- Unsoldering station DSEA 4001 (SEM)
- Solder wick Easy Braid (no clean)
- Rework flux: Kester 952-D6

5.2.2 Process

- If using unsoldering station: fix the parameters of the unsoldering station
 - Max temperature : 385 °C
 - Unsoldering pipe. Inner diameter: 1mm
- If using solder iron :
 - Max temperature : 385 °C
 - Same solder tip than for initial assembly
- Unsolder the CPU leg by leg
 - Put the unsoldering pipe or the solder iron on one leg.
 - Wait a few seconds (5 to 10) until the solder is in fusion.
 - Activate the aspiration while pushing on the pedal or use solder wick with solder iron.
 - Be sure there is no solder left, else repeat the operation
 - Repeat the operation for each leg.
- Remove the CPU
- Check there is no solder left and that the pads are OK.
- Clean the pads, if necessary, with iron or solder wick.

5.3 Acceptance criteria

- Purpose : to ensure the RMA Wireless CPU returning from customers are in good condition and can be repaired in WM repair center.
- Criteria : When removing Q2686 CPU from customer application board, ensure that the belt is not unsoldered from the PCB and that the PCB is not deformed.

www.DataSheet4U.com

5.4 Solder new Wireless CPU

See chapter 5.2.1

APPENDIXES

www.DataSheet4U.com

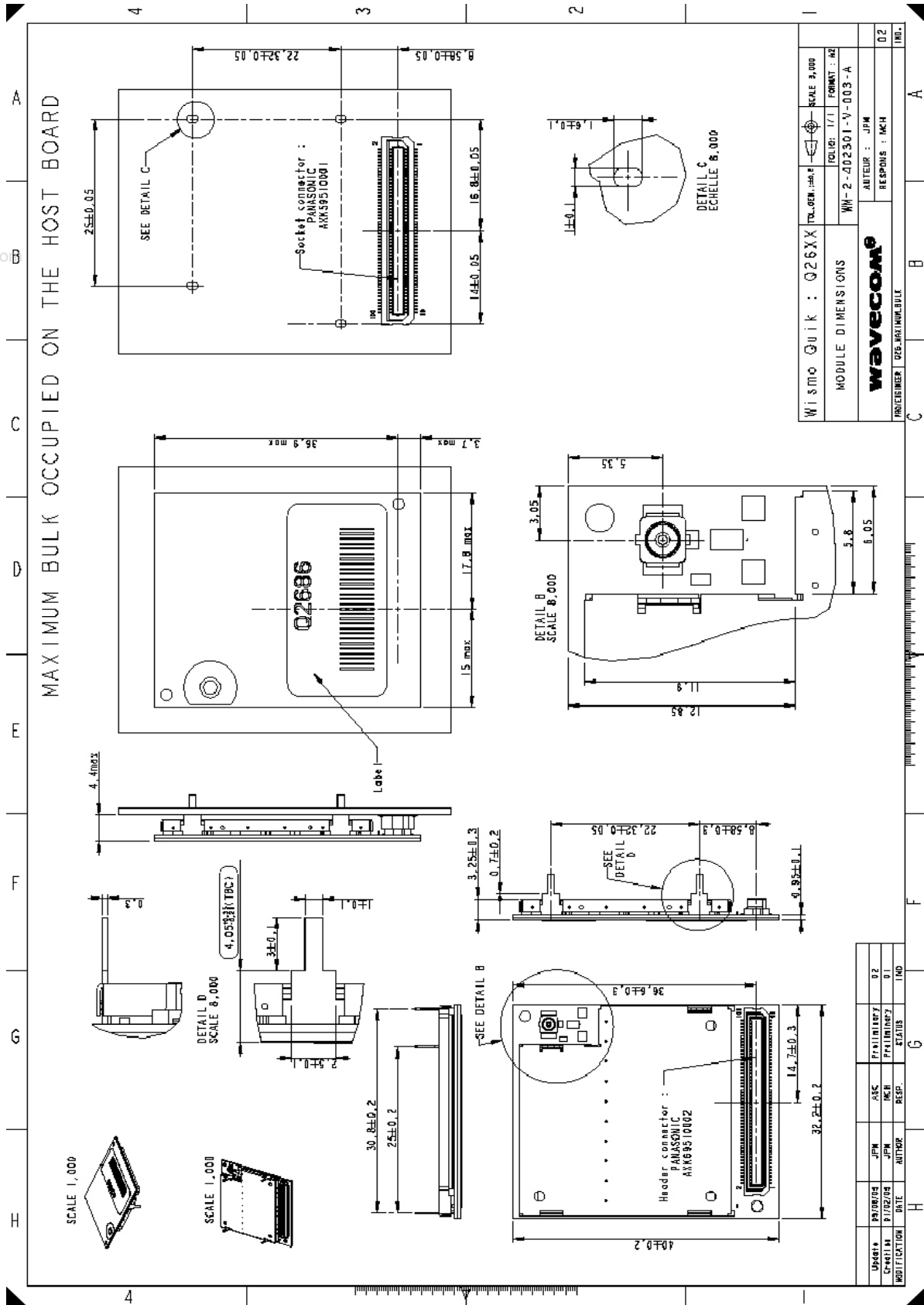

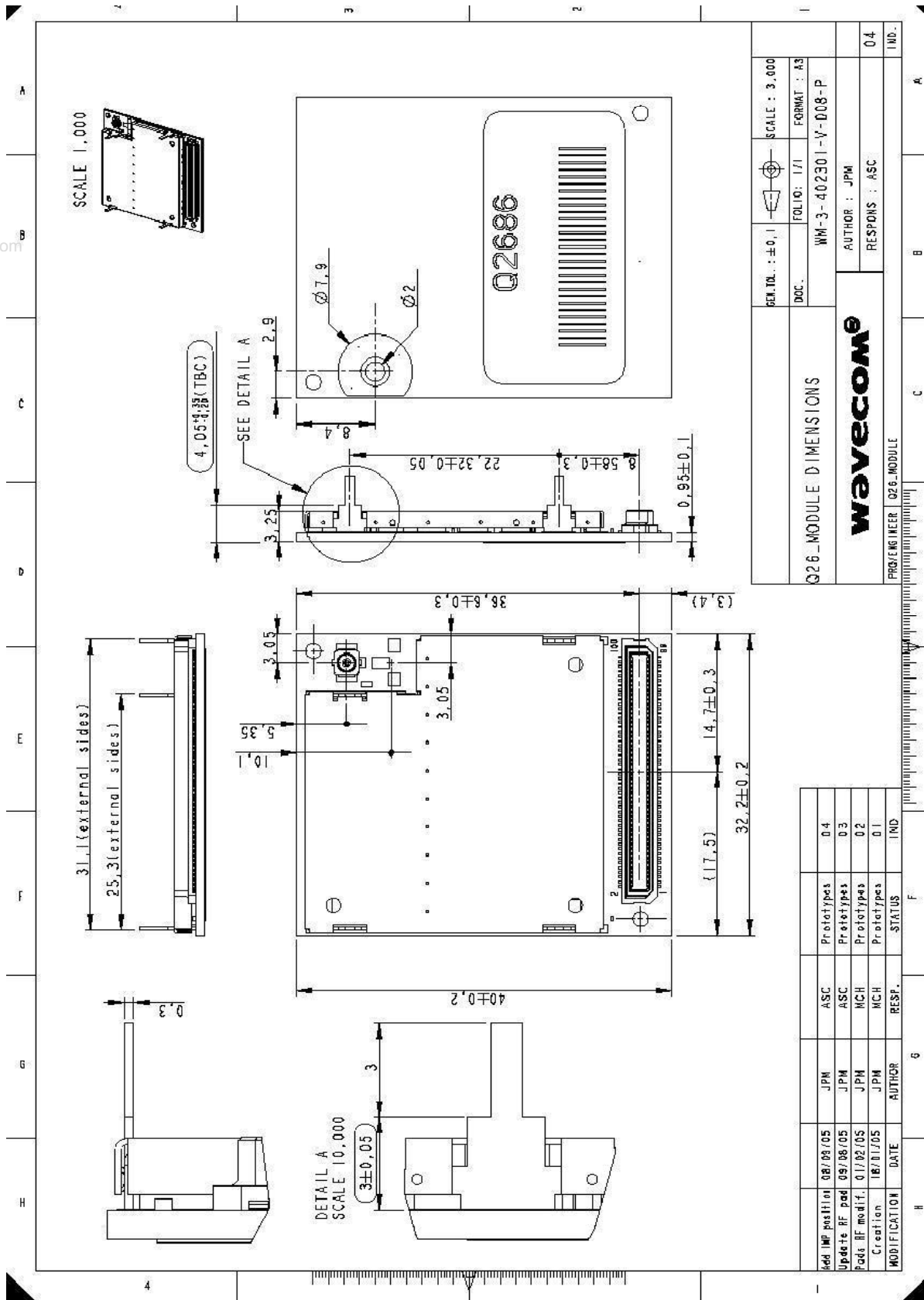

www.DataSheet4U.com

IMP CONTACT PAD _ WAVECOM SIDE

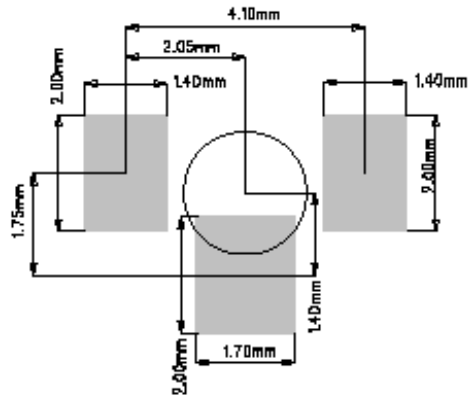

INDUSTRIAL NORMALIZATION	WRITTEN BY : HER	DATE : 07/02/06
	APPROVED BY : ASC	SECTION : 01P102
wavecom	IMP CONNECTOR PAD DESIGN	

CHIPS & BORING DIAMETER

of the WISMO QUIK mechanical insertion pins

CASE N 1
To be used in priority

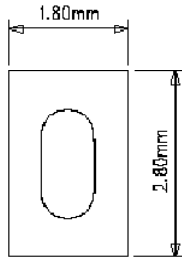

CASE N 2
on specific request

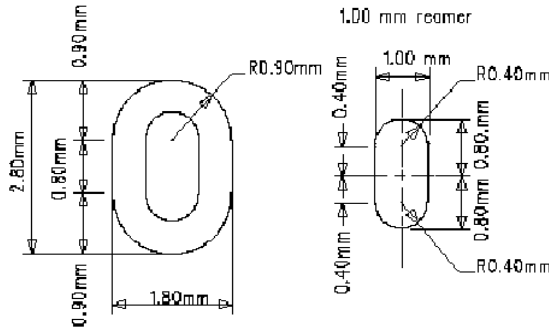

Tolerance +/- 0.1mm
1.00 mm reamer

CASE N 3
Other

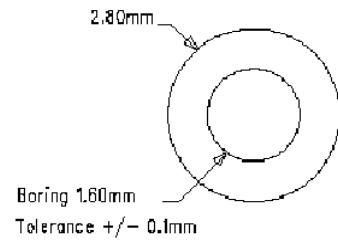

Boring 1.60mm
Tolerance +/- 0.1mm

THERMAL BRAKES DEFINITION

