

# PFM21030 SPECIFICATION

## 2110-2170 MHz, 30W, 2-Stage Power Module

### Enhancement-Mode Lateral MOSFETs

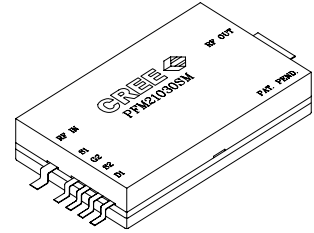

**Package Type: Surface Mount**

**PN: PFM21030SM**

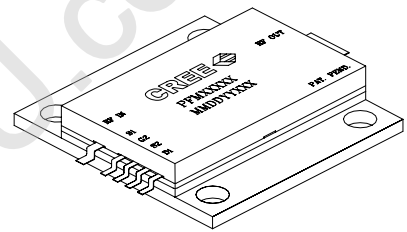

**Package Type: Flange**

**PN: PFM21030F**

This versatile UMTS module provides excellent linearity and efficiency in a low-cost surface mount package. The PFM21030 includes two stages of amplification, along with internal sense FETs that are on the same silicon die as the RF devices. These thermally coupled sense FETs simplify the task of bias temperature compensation of the overall amplifier. The module includes RF input, interstage, and output matching elements. The source and load impedances required for optimum operation of the module are much higher (and simpler to realize) than for unmatched Si LDMOS transistors of similar performance.

The surface mount package base is typically soldered to a conventional PCB pad with an array of via holes for grounding and thermal sinking of the module. Optimized internal construction supports low FET channel temperature for reliable operation.

- 27 dB Gain
- 30 Watts Peak Output Power
- Internal Tracking FETs (for improved bias control)
- WCDMA Performance
  - 5 Watts Average Output Level
  - 18% Power Added Efficiency
  - 45 dBc ACPR

### Module Schematic Diagram

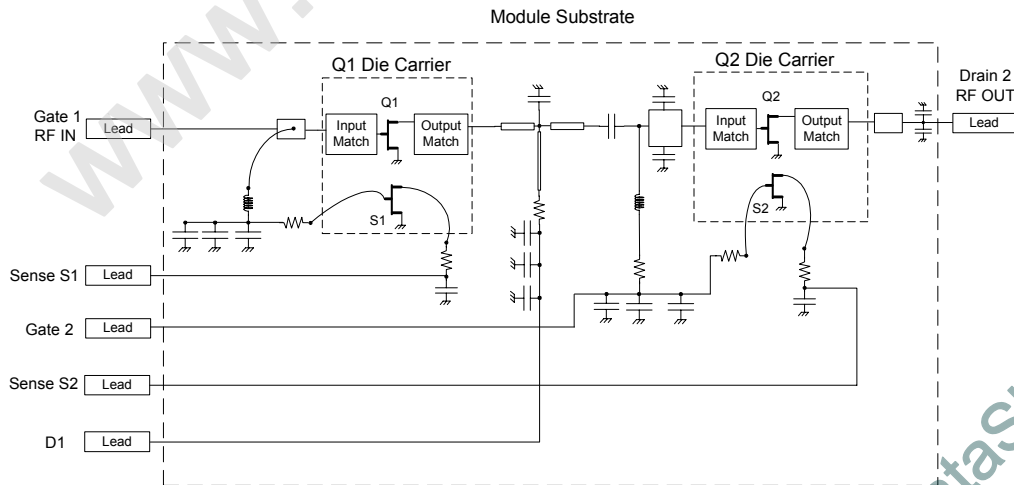

*Note: Additionally, there are 250K Ohm resistors connected in shunt with all leads, to enhance ESD protection.*

## Electrical Specification

	Parameter	Limits			Units	Comments
		Min	Typ	Max		
1	Operating Frequency	2110	-	2170	MHz	
2	Gain	25	26.7	30	dB	Note 1.
3	Gain Compression at Pout =30 Watts	-	1.3	2.0	dB	Pulsed CW compression measurement (12 μsec pulse, 120 μsec period, 10% duty cycle).
4	Gain Flatness over any 30 MHz bandwidth	-	± 0.1	± 0.3	dB	
5	Deviation from Linear Phase over any 30 MHz bandwidth	-	± 1.0	± 2.0	°	
6	Group Delay	-	3.5	3.8	nanosec	Includes delay of test fixture (~0.6 nanoseconds).
7	ACPR with WCDMA Pave = 5 W	-40	-44	-	dBc	Note 3. Refer to applications data for performance with other protocols.
8	Efficiency under WCDMA Protocol, Pave = 5 W	17	19	-	%	Note 3.
9	Efficiency @ 30W CW Output		40	-	%	
10	DC Drain Supply Voltage	24	27	30	Volts	Testing for conformance with RF specifications is at +27 V.
11	Operating Temperature Range (base temperature)	-40	-	+115	°C	Testing for conformance with RF specification is at +25 °C.
12	Gain Variation versus Temperature	-	-0.033	-	dB/°C	Bias quiescent currents held constant.
13	Output Mismatch Stress	-	-	30	Watts CW	VSWR 10:1, all phase angles. No degradation in output power before & after test.
14	Stability	-60	-	-	dBc	0<Pout<44.8 dBm CW, 3:1 VSWR
15	Theta jc (channel)	-	-	2.1	°C/W	Theta jc is for output device. Verified with IR scan. Note 2.
16	Quiescent Currents a) Q1 b) Q2		80 240		mA mA	These DC quiescent currents are typical of the levels that produce optimum linearity for CDMA protocol.
17	Tracking FET Periphery Ratio a) Stg 1 Track b) Stg 2 Track		3.0 1.7		% %	Ratio of sense FET current, relative to RF FET current. Ratios are: Stg 1: 33:1; Stg 2: 58:1 Gates of sense & RF FETs are DC connected. Measured with no RF signal present.
18	ESD Protection a) Human Body Model b) Machine Model	Class 1 Class M3				a) 2000V, 100 pF, 1500 Ohms b) 400V, 200 pF, zero Ohms Mil STD 883E, Method 3015 for Human Body Model and for Machine Model.

## Electrical Specification (Continued)

### MAXIMUM RATINGS

	Rating	Symbol	Value	Units
19	DC Drain Supply			
	a) Drain-to-Source Voltage, ( $V_{GS}=0$ ), D1 & D2 & Track D1 & Track D2	$V_{DS}$	+50	Volts DC
	b) Normal Operation (Class AB operation)	$V_{D\ SUPPLY}$	+30	Volts DC
20	DC Gate Supply			
	a) Gate-to-source Voltage ( $V_{DS}=0$ )	$V_{GS}$	$-0.5 < V_{GS} < +15$	Volts DC
	Normal Operation (Class AB operation)	$V_{G\ SUPPLY}$	$0 < V_{GS} < +6$	Volts DC
21	RF Input Power	$P_{IN}$	+25	dBm
22	Maximum Power Dissipation ( $T \leq +85\ ^\circ\text{C}$ )	$P_{TOTAL}$	65	Watts
	a) Derate above +85 °C base temperature.		-0.7	Watts/°C
23	Maximum Channel Operating Temperature	$T_{CH}$	+200	°C
24	Storage Temperature Range	$T_{STG}$	-40 to +150	°C

### RECOMMENDED SOURCE AND LOAD IMPEDANCES

	Impedance	Units	Comments
Nominal Source Impedance for Optimum Operation	$18.3 - j0.1$	Ohms	Matched for optimum linearity and gain flatness. Impedance is looking from the module input lead into the input matching circuit. Reference plane is 0.105 inches from input end of module.
Nominal Load Impedance for Optimum Operation	$23.7 + j3.8$	Ohms	Matched for optimum efficiency under WCDMA protocol. Impedance is from the module output lead looking into the output matching circuit. Reference plane is 0.105 inches from output end of module.

### Specification Notes:

- 1) The module is mounted in a test fixture with external matching elements for all testing. Quiescent current bias conditions are those appropriate for minimum ACPR under CDMA protocol. Supply voltage for all tests is +27 volts DC. Testing is at +25 °C unless otherwise specified.
- 2) Theta<sub>jc</sub> is measured with a package mounting (base) temp of +85 °C, and with 10 Watts CW output.
- 3) P<sub>out</sub>=5 Watts average; WCDMA protocol: (3GPP Test Model 1, 64 DPCH.).  
ACPR conditions: 5.00 MHz offset, 3.84 MHz BW (crest factor = 11 dB).
- 4) Sense FETs are scaled versions of the main RF FETs, formed from electrically isolated cells at end of the RF structure. Current scales according to periphery (threshold voltages offset is less than ±150 millivolts between adjacent devices). RF & Sense FET gates and sources are DC connected. Drains are DC isolated. Leads S1 & S2 are DC connected to drains of sense FETs 1 & 2. Sources are connected to package base. Sense FETs are electrically isolated from the RF signals.

## Typical Module Performance

T=+25 °C, unless otherwise noted. Data is for module in a test fixture with external matching elements. See following page for test fixture details.

Typical Small-Signal Gain vs. Frequency

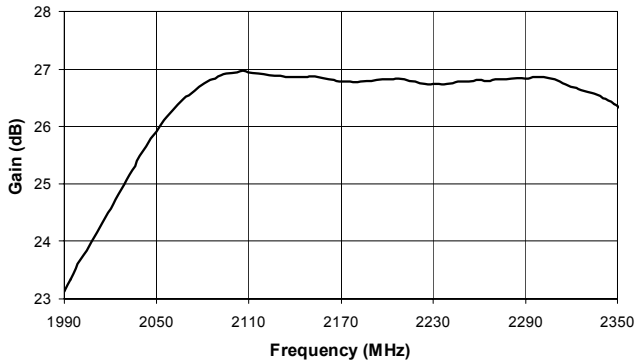

Typical CW 2-Tone Intermods vs. Output Power

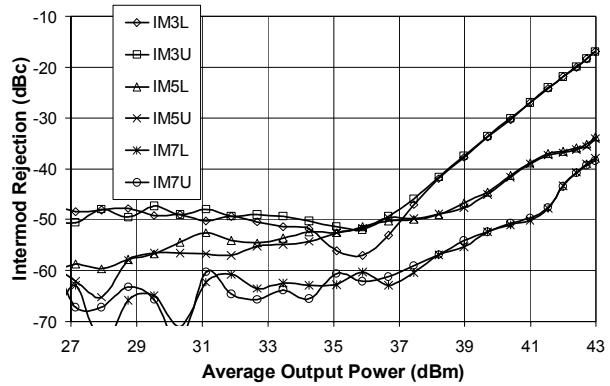

Typical Input & Output Return Loss vs Freq.

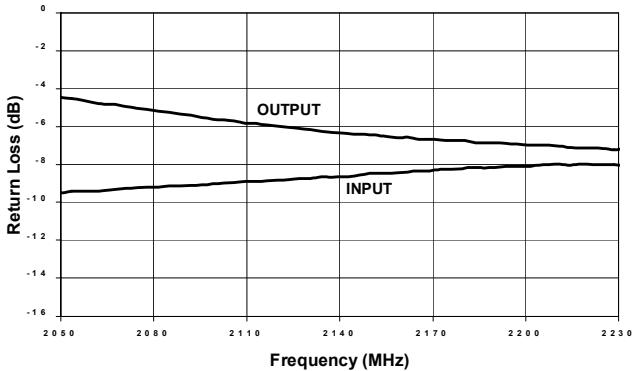

Typical Gain & Efficiency vs CW Output Power

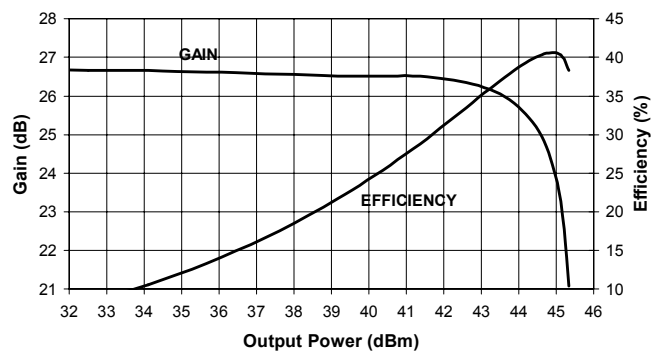

Note: The above data is for initial prototype units. Consult the factory for latest data.

## PFM21030SM Package Outline

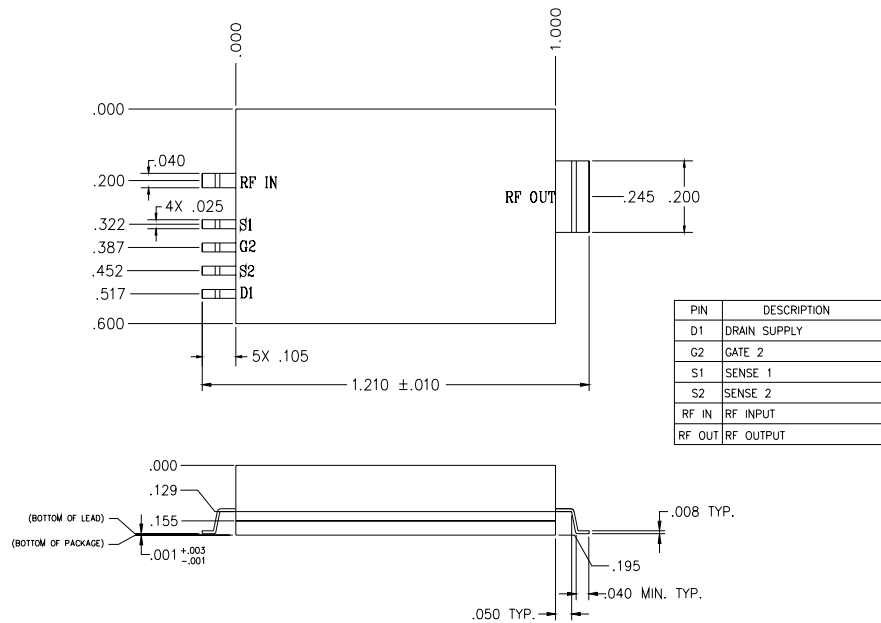

## PFM21030F Package Outline

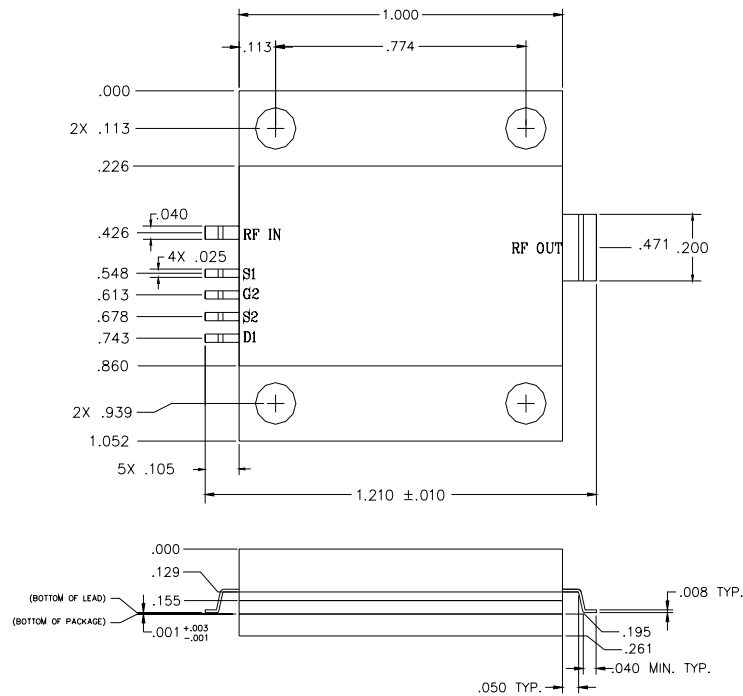

## Module Application Notes

The PFM21030 was designed to provide a versatile low cost solution for a wide variety of wireless applications requiring 30 Watt peak output levels. This hybrid module contains two stages of Si LDMOS FET amplification: a nominally 5 Watt input stage driving a 30 Watt output stage. The module is optimized for efficient, linear operation with WCDMA signals. The input and output of this module are partially matched, and require source and load impedances of nominally 19 and 21 Ohms (much higher than typically required by unmatched Si LDMOS FETs). These source and load impedances can be achieved with compact conventional external PCB circuitry.

Performance for particular signal protocols can be improved slightly by small adjustments in quiescent currents and load impedances presented to the module. The data presented in the previous pages was taken at one set of quiescent currents and in a fixture with source and load impedances that were fixed for all measurements. The data presented is generally representative of the performance— benefits from further optimization in quiescent current are small.

In addition to the two RF gain stages, there are Sense FET (thermally tracking) devices that serve as optional DC circuit elements. The Sense FETs are fabricated on the same epi material with nominally identical physical characteristics (but smaller gate periphery) as the RF devices. The sense devices can be applied as temperature compensation elements in conjunction with external bias circuitry. Alternatively, the two-stage amplifier can be operated with the Sense FETs unused (S1 and S2 leads floating).

The base of the module is high conductivity copper of 40 mil thickness. It is well matched to typical PCB material, and it serves as a heat spreader for the device when mounted as a surface-mount component. The module thermal characteristics were measured with the unit soldered to a 20 mil thick PCB material with an array of plated via holes for electrical grounding and thermal sinking. IR scans of this configuration demonstrated maximum die channel temperatures of 142 degrees C with a PCB base temperature of +95 degrees C, and 10 Watts CW output power.

These modules can be provided in tape-and-reel configuration for high volume application

## Typical PCB Mounting Pattern

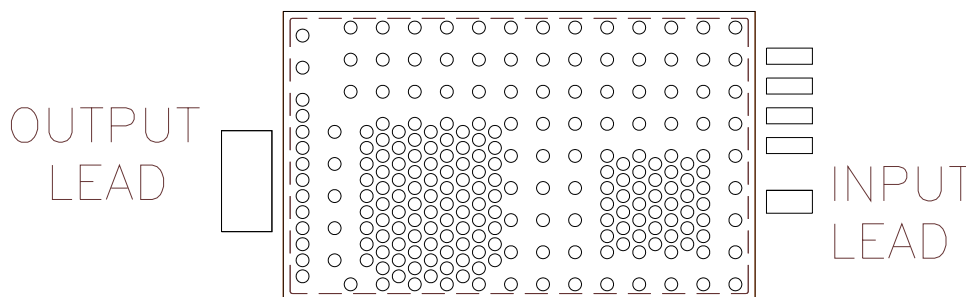

The module outline is indicated by dashed line (0.60 X 1.00 inches). The ground pad is 1.030 X 0.630 inches. Ground vias in this example are 28 mil diameter on 35 mil (or 70 mil) centers. Thermal resistance is proportional to the thickness of the PC board (height of vias), and inversely proportional to the total ground hole array periphery (and thickness of plating in the holes). The densely spaced vias in this layout (on 35 mil spaces) are located in areas of maximum heat generation. The gap between the lead pads and the ground pad is 25 mils. Note that the underside of the PCB must be connected to a thermal heat sink and ground.

The above hole pattern is an example of one that maximizes thermal transfer. There are numerous alternative approaches. Depending on the application (signal protocol, thermal environment, etc.), the number of via holes can be reduced. High average power applications require the most extensive thermal sinking.

## Recommended Passive Bias Circuit

This schematic demonstrates a method of applying the Sense FETs internal to the module that uses passive external circuitry. The circuit maintains a constant current through the Sense FETs, independent of temperature of the die. The Sense FETs are configured in this case as diodes. The temperature dependence of the  $V_f$  of the diode is very similar to that of the RF FET gate voltage, and therefore the quiescent current remains nearly constant over a wide temperature range. The advantage of this circuit is its simplicity and stability (avoidance of operational amplifiers) under all layout conditions. The main limitation of the circuit is that quiescent currents must be adjusted for each individual module (they are not easily pre-set with precision).

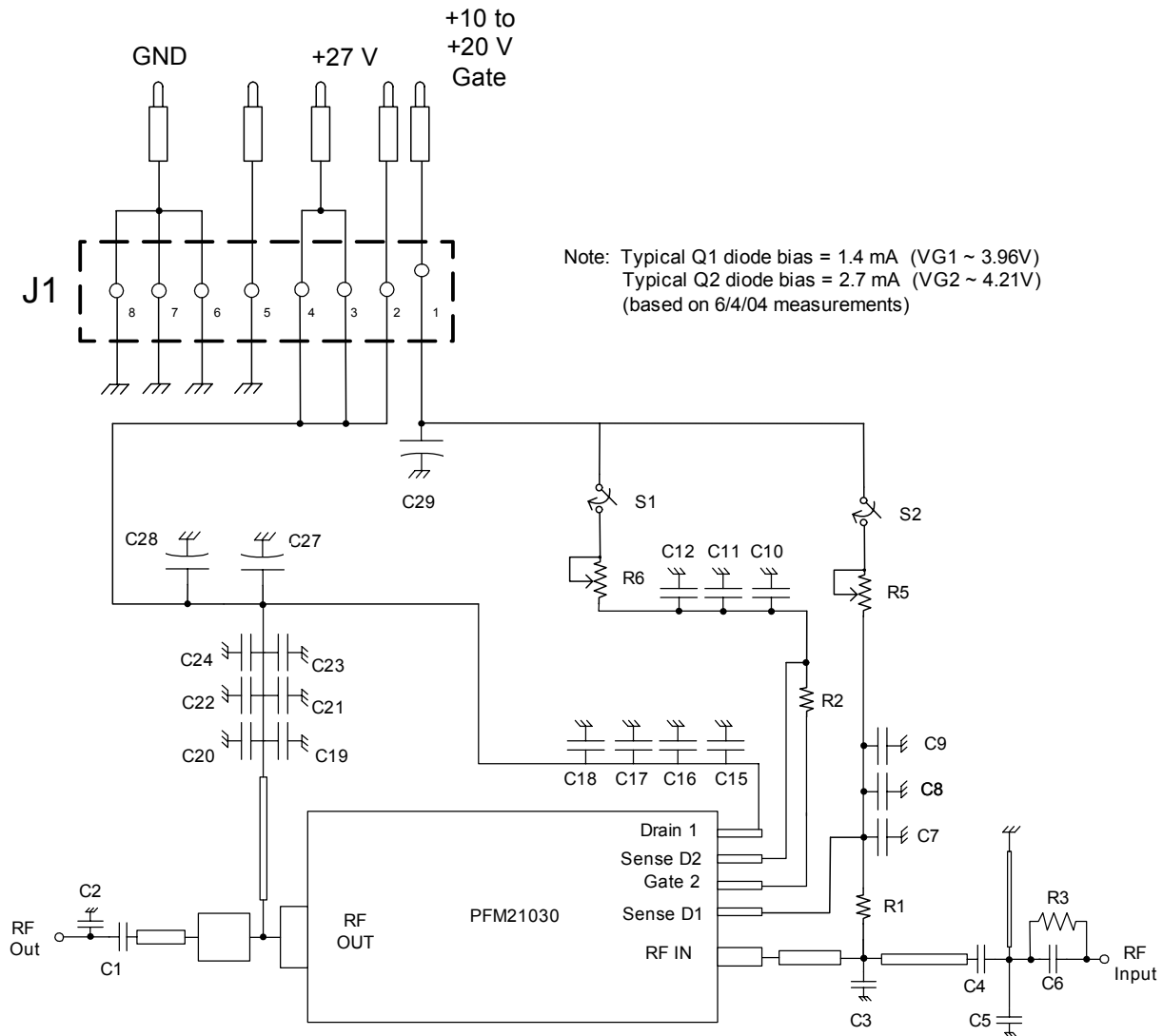

## Alternate Passive Bias Circuit Parts List

<u>Designator</u>	<u>Description</u>	<u>Qty</u>
C1	CAP, 10 PF±0.5 pF, 0603, ATC 600S	1
C2	CAP, 0.8 PF±0.1 pF, 0603, ATC 600S	1
C3	CAP, 1.5 PF±0.1 pF, 0603, ATC 600S	1
C5	CAP, 1.0 PF±0.1 pF, 0603, ATC 600S	1
C4, C6	CAP, 3.3 PF±0.1 pF, 0603, ATC 600S	2
C7, C19, C20	CAP, 24 PF±5%, 0603, ATC 600S	3
C10, C13, C14, C15,	CAP, 24 PF±5%, 100V (min), 0603, any vendor.	4
C8, C11, C16, C21	CAP, 470 PF ±10%,100 V, 0603, any vendor.	4
C22	CAP, 3300 PF±10%, 100 V, 0603, Murata GRM39X7R332K100??, or equivalent.	1
C23, C9, C17, C12	CAP, 15000 PF±10%, 100 V, 0805, Murata GRM40X7R153K100??, or equivalent.	4
C24, C18	CAP, 150000 1206, 50V, X7R, 10% Suggest Murata GRM42-6-X7R-154-K-050-A-L or equivalent.	2
R5	RES, potentiometer, 10K ohms, Digikey SM4W103-ND	1
R6	RES, potentiometer, 5K ohms, Digikey SM4W502-ND	1
R1	RES, 1/16W, 0603, 1000 ohms	1
R3	RES, 1/16W, 0603, 42 ohms	
C27	CAP, 2.2uf SMT TANTALUM, 50V (240097)	1
C29	CAP, 10uf 16V SMT TANTALUM (240096)	1
C28	CAP, 47UF, 50V, ELECTR SMT (240087)	1
S1, S2	SPST Switch, Digikey PN CKN1100CT-ND	2



## Test Fixture

A metal backed PCB with clamps for securing module is used for module electrical testing and for product demonstration. The fixture is supplied mounted to a finned heat sink. A fixture schematic is provided on the following page.

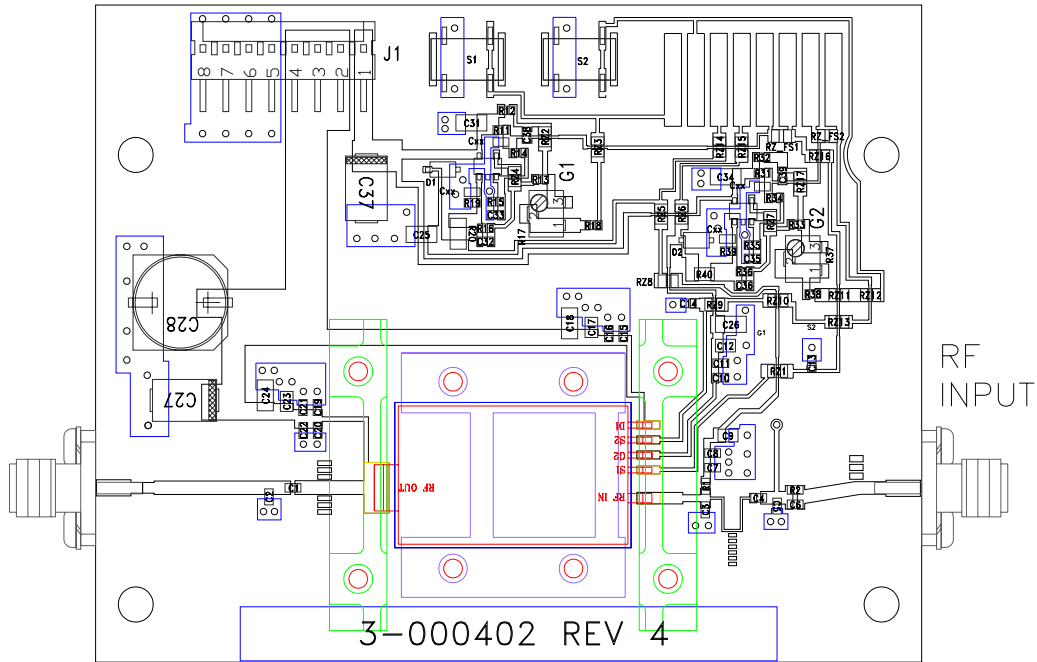

This test fixture uses an active bias circuit, which sets the bias circuit through the Sense FETs (configured as FETs) and applies the derived gate voltage to the associated RF FETs. This assures particular quiescent bias currents, with accuracy determined by the Sense FET-to-RF FET current ratios.

## Test Fixture (with active bias circuit) Schematic

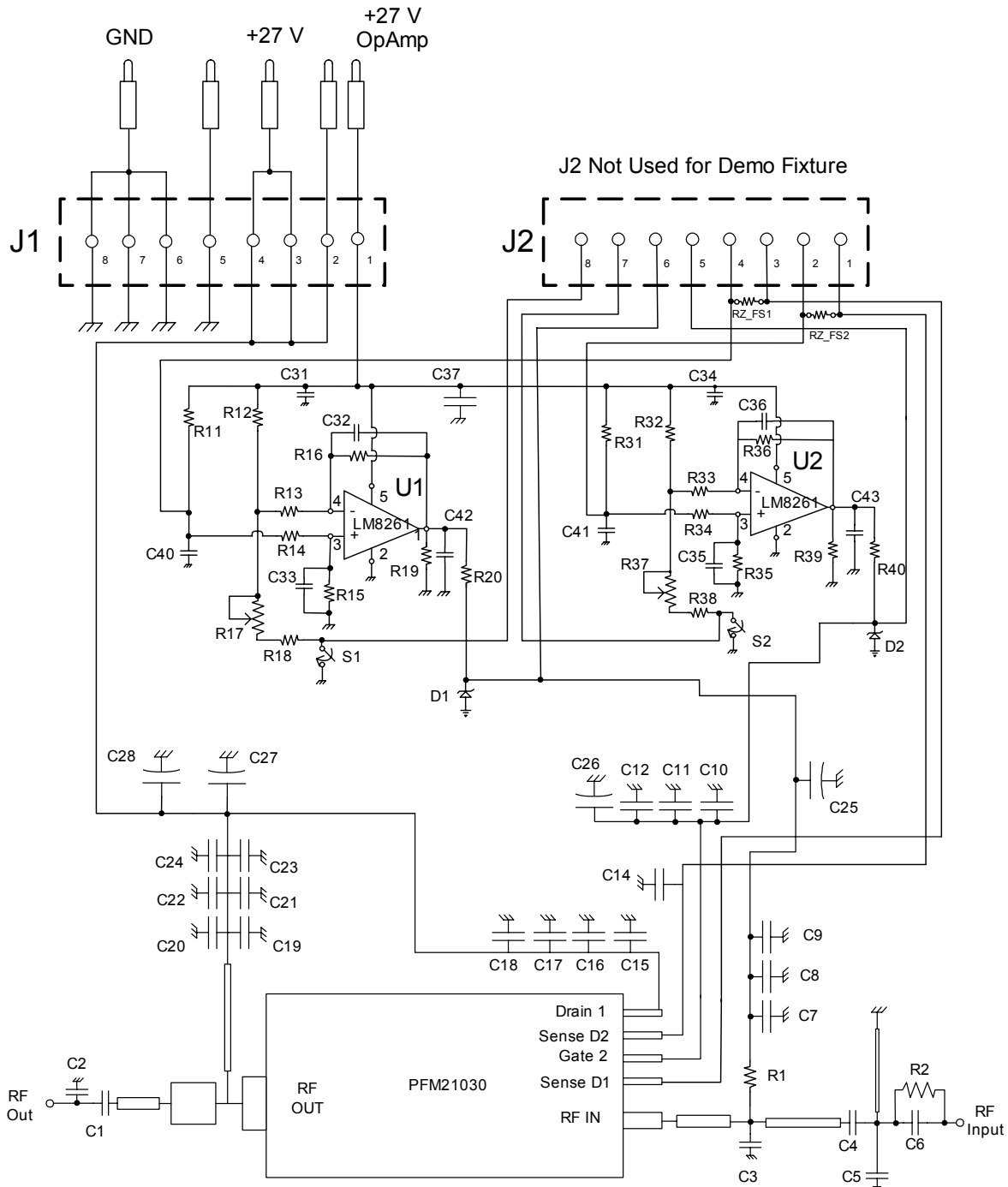

See the following pages for the parts list and a description of the principle of operation. Note that an alternative, less complex bias scheme is provided on page 10. The advantage of the above active bias design is that bias currents are set by the RF-to-Sense FET ratios, and once the optimum bias circuit resistor (potentiometer) values are established, the circuit can stay fixed for multiple modules (thus eliminating

module-specific bias alignment). Additionally, aging effects are minimized because of the similar bias conditions for Sense and RF FETs. The disadvantage of this design is its relative complexity and the incorporation of operational amplifiers, for which stability is potentially circuit layout dependent.

## Parts List for Cree Microwave Test Fixture

<u>Designator</u>	<u>Description</u>	<u>Qty</u>
C1	CAP, 10 PF±0.5 pF, 0603, ATC 600S	1
C2	CAP, 0.8 PF±0.1 pF, 0603, ATC 600S	1
C3	CAP, 1.5 PF±0.1 pF, 0603, ATC 600S	1
C5	CAP, 1.0 PF±0.1 pF, 0603, ATC 600S	1
C4, C6	CAP, 3.3 PF±0.1 pF, 0603, ATC 600S	2
C7	CAP, 24 PF±5%, 0603, ATC 600S	1
C19, C20	CAP, 24 PF±5%, 0603, ATC 600S	2
C10, C13, C14, C15,	CAP, 24 PF±5%, 100V (min), 0603, any vendor.	4
C8, C11, C16, C21	CAP, 470 PF ±10%,100 V, 0603, any vendor.	4
C22	CAP, 3300 PF±10%, 100 V, 0603, Murata GRM39X7R332K100	1
C9, C23, C17, C12	CAP, 15000 PF±10%, 100 V, 0805, MurataGRM40X7R153K100	4
C18, C24, C25, C26, C31, C34	CAP, 150000 1206, 50V, X7R, 10% Murata GRM42-6-X7R-154-K-050-A-L	6
C27, C37	CAP, 2.2uf SMT TANTALUM, 50V	2
C28	CAP, 47UF, 50V, ELECTR SMT	1
C33, C35	CAP, 18,000 PF ±10%,100 V, 0603	2
C32, C36	CAP, 33,000 PF ±10%,100 V, 0603	2
C40, C41, C42, C43	CAP, 1000 PF ±10%,100 V, 0603.	4
R1	RES, 1/16W, 0603, 1000 ohms, 5%	1
R2	RES, 1/16W, 0805, 42 Ohms, 5%	1
R11, R12	RES, 1/16W, 0603, 332 Ohms, 1%	2
R31, R32	RES, 1/16W, 0603, 147 Ohms, 1%	2
R13, R14, R33, R34	RES, 1/16W, 0603, 2370 Ohms, 1%	4
R16, R15, R35, R36	RES, 1/16W, 0603, 511 KOhms, 1%	4
R19, R39	RES, 1/16W, 0603, 100 KOhms, 5%	2
R18	RES, 1/16W, 0603, 3320 Ohms, 5%	1
R38	RES, 1/16W, 0603, 2000 Ohms, 5%	1
R20, R40	RES, 1/8W, 1206, 1000 Ohms, 5%	2
R17, R37	RES, potentiometer, 10 Kohms, Digikey SM4W103-ND, 11T	2
RZ_FS1, RZ_FS2	RES, 1/16W, 0805, 0 Ohms (used as jumpers, demo fixture only)	2
D1, D2	Zener diode, 6.2 V, Digikey PN BZT52C6V27DICT-ND	2
S1, S2	SPST Switch, Digikey PN CKN1100CT-ND	2
U1, U2	Op Amp, High Output, LM8261M5 (5 pin, SOT23 package)	2

It is also possible to bias the two stages in a conventional manner, with the two tracking FET drains left unused (floating or grounded). The above bias circuits are just two of several possibilities.

## Test Fixture Active Bias Circuit Principles of Operation

The active bias circuit test fixture operates off of a single voltage supply. It contains two switches and two potentiometers. The switches provide for independent on/off for the input and output devices of the module. The potentiometers allow adjustment of quiescent current level of each stage. The adjustments should be made with no RF applied to the module.

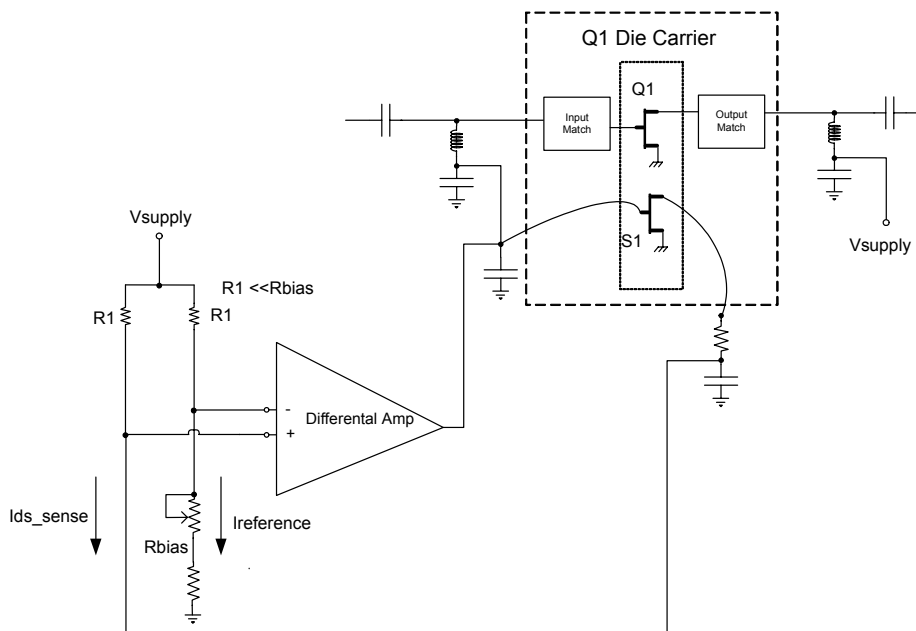

Principal of Operation of Bias Circuitry

The principal of operation of the fixture bias circuit is demonstrated in the above Figure. The potentiometer establishes a reference current, and the operational amplifier adjusts gate voltage to maintain that current in the sense device. The same DC gate voltage is also applied to the main (RF) device. Sense devices are scaled versions of the main (RF) devices, on the same die (to facilitate temperature tracking). As the temperature of the die changes due to RF drive (or ambient temperature changes), the operational amplifier maintains constant current through the Sense FET, and thus constant quiescent bias for the main (RF) FET. No RF signal is applied to the Sense FET.

There is a separate independent bias circuit for the input (Q1) device and for the output device (Q2) of the module.

Experience has shown this bias circuit to be a reliable method of maintaining tight control of quiescent current over operating temperature, and for minimizing the impact of device aging effects on amplifier performance. However, there are some precautions regarding use of this circuit. The principle of the circuit is for the differential amplifier (op amp) to adjust gate voltage until the desired current is achieved through the sense FETs. If the current path is interrupted (thereby not allowing  $I_{ds\_sense}$  to flow), the operational amplifier will increase gate bias in an attempt to increase current, with the possibility that the quiescent bias current in the RF FET may increase beyond a safe limit (the device may be destroyed). The zener diodes in the test fixture circuit (D1 and D2, test fixture schematic) are safeguards for prohibiting excessive gate voltage to be applied to the transistors.



# PFM21030

**Disclaimer:** Specifications are subject to change without notice. Cree Microwave, Inc. believes the information contained within this data sheet to be accurate and reliable. However, no responsibility is assumed by Cree Microwave for any infringement of patents or other rights of third parties, which may result from its use. No license is granted by implication or otherwise under any patent or patent rights of Cree Microwave. Cree Microwave makes no warranty, representation or guarantee regarding the suitability of its products for any particular purpose. “Typical” parameters are the average values expected by Cree Microwave in large quantities and are provided for information purposes only. These values can and do vary in different applications, and actual performance can vary over time. All operating parameters should be validated by customer’s technical experts for each application. Cree Microwave products are not designed, intended, or authorized for use as components in applications intended for surgical implant into the body or to support or sustain life, in applications in which the failure of the Cree product could result in personal injury or death, or in applications for planning, construction, maintenance or direct operation of a nuclear facility. Cree Microwave is a trademark and Cree and the Cree logo are registered trademarks of Cree, Inc.

## **Contact Information:**

Cree Microwave, Inc.  
160 Gibraltar Court  
Sunnyvale, CA 94089-1319

Sheryle Henson (Cree Microwave—Marketing Manager) 408-962-7783  
Tom Dekker (Cree Microwave—Sales Director) 919-313-5639