

1/8, 1/9, 1/10 Duty BITMAP LCD DRIVER with KEY SCAN

■ GENERAL DESCRIPTION

The **NJU6538** is a 10-common x 65-segment bitmap LCD driver to display graphics or characters.

It contains 650 bits display data RAM, microprocessor interface circuit, common and segment drivers, key scan circuit, and general output ports.

An image data from MPU through the serial interface is stored into the 650 bits internal displayed on the LCD panel through the commons and segments drivers.

The **NJU6538** displays 10 x 65 dots graphics or 11-character 1-line by 5 x 7 dots character + 3 x 65 dots icons. It contains key scan circuit transmitting the 25-keys maximum (5 x 5 = 25) to MPU.

Also it provides 4 general purpose output ports with PWM output function maximum to drive LEDs or others directly.

Furthermore, the NJU6538 can select a LCD driving voltage out of 16 steps voltage by the instruction adjust the display contrast of LCD panel.

■ PACKAGE OUTLINE

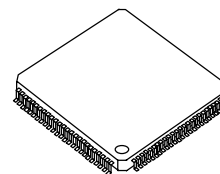

NJU6538FG1

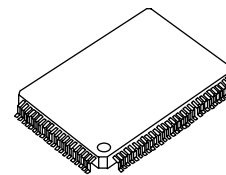

NJU6538FC2

■ FEATURES

- Direct Correspondence between Display Data RAM and LCD Pixel
- Display Data RAM : 650-bits
- LCD Drivers : 65-seg, 10-com
- Serial interface (SIO, SCL, CS)
- Programmable Duty Ratio
 - 1/8 Duty : 7-common x 65-segment + 1-icon common
 - 1/9 Duty : 7-common x 65-segment + 2-icon common
 - 1/10Duty : 7-common x 65-segment + 3-icon common
- Bias Ratio : 1/4 bias
- 25-key scan Function (5 x 5 matrix)
 - Needless for anti-reverse current diodes in key scan
- general Output Ports with 128-steps PWM output (possible LED driving) maximum 4-ports
- Useful Instruction Set
 - Display ON/OFF, Page Address Set, Column Address Set, Display Data write, ADC Select, Inverse Display ON/OFF, whole display ON/OFF, Reset, EVR Register Set, Duty Select, Power Save mode set, General Output Port PWM phase / frequency set, General Output Port PWM data set, General Output Port / Key scan output select
- Bleeder Resistance On-chip
- Software Contrast Control (16 steps)
- Operating Voltage
 - Logic Operating Voltage : 2.7 to 5.5V
 - LCD Driving Voltage : 5.0 to 10.0V
- Package Outline : QFP100-G1
QFP100-C2
- C-MOS Technology (Substrate: P)

NJU6538

PIN CONFIGURATION

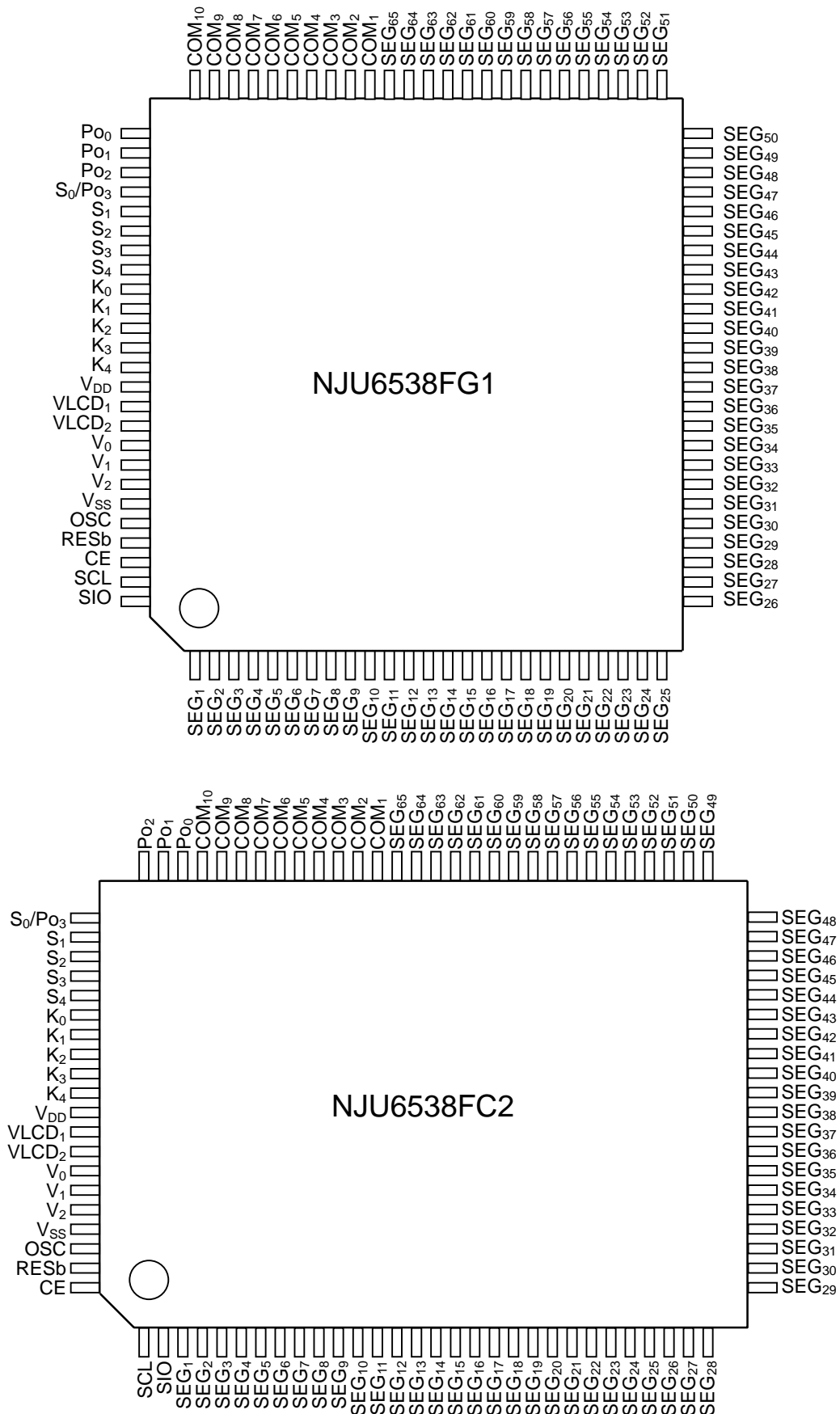

■ BLOCK DIAGRAM

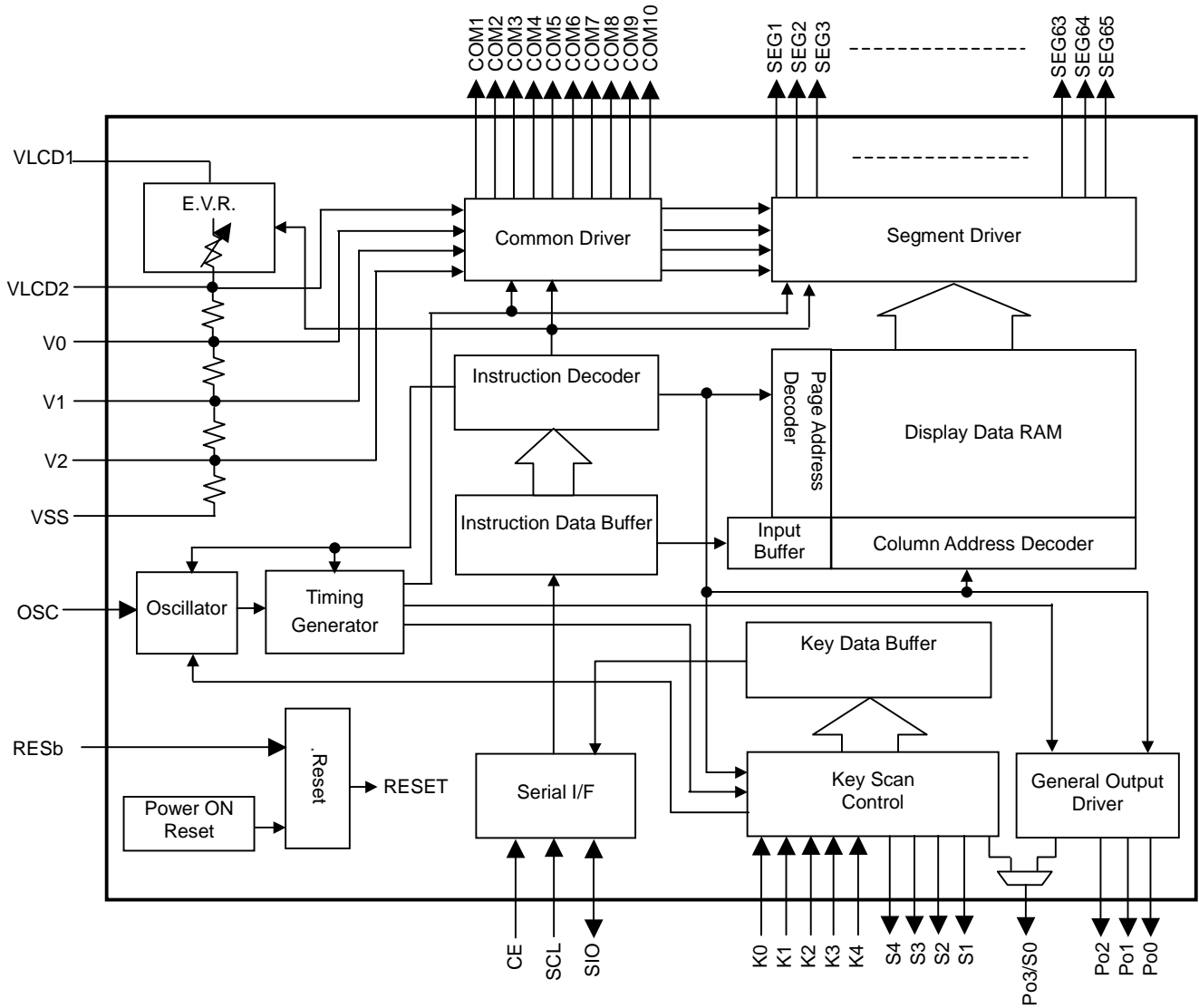

■ TERMINAL DESCRIPTION

No.		Symbol	I/O	Description
FG1	FC2			
1 to 65	3 to 67	SEG ₁ to SEG ₆₅	O	Segment output terminal.
66 to 72	68 to 74	COM ₁ to COM ₇	O	Common output terminal.
73 to 75	75 to 77	COM ₈ to COM ₁₀	O	Icon common output terminal.
76 to 78	78 to 80	Po0 to Po2	O	General output port 128-step PWM waveform output by MPU control.
79	81	Po3/S ₀	O	General output port / Key scanning input terminal Select General output port or Key scanning input terminal by the instruction. A function must be selected either Po3 or S ₀ General output port 128-step PWM waveform output by MPU control. Key scanning input terminals (No need for anti-reverse current diode in key scan)
80 to 83	82 to 85	S ₁ to S ₄	O	Key scanning input terminals. (No need for anti-reverse current diode in key scan)
84 to 88	86 to 90	K ₀ to K ₄	I	Key scanning input terminals. (with internal pull-down resistor)
89	91	V _{DD}	-	Power supply terminal.(2.7V to 5.5V)
90	92	VLCD1	I	LCD driving voltage input terminal.
91	93	VLCD2	I	LCD driving voltage stabilization capacitor terminals. Connect the capacitor between each terminal and V _{SS} .
92	94	V ₀		
93	94	V ₁		
94	96	V ₂		
95	97	V _{SS}	-	Ground terminal.
96	98	OSC	I/O	Oscillator terminal. Connect the external resistor.
97	99	RESb	I	Reset terminal. (with internal pull-up resistor) In case of only Power-on Reset should be open.
98	100	CE	I	Chip enable terminal
99	1	SCL	I	Serial clock input terminal
100	2	SIO	I/O	Serial Data input or output terminal

■ FUNCTIONAL DESCRIPTION

- (1) Description for each blocks
 - (1-1) Serial I/F
The serial I/F controls serial data from external data.
 - (1-2) Instruction data buffer
The instruction data buffer stores instruction code from external.
 - (1-3) Instruction decoder
The instruction decoder decodes instruction code and controls each blocks.
 - (1-4) Display data RAM
The Display data RAM stores data for display from MPU.
 - (1-5) Segment driver
The Segment driver generates driving waveform to segment terminal on display data.
 - (1-6) General output driver
The General output driver generates output signal level to general output terminal on output data.
 - (1-7) Common driver
The Common driver generates driving waveform to common terminal.
 - (1-8) Electrical Variable Resistance (E.V.R.)
The Electrical Variable Resistance adjusts LCD driving voltage from V0 to V2.
 - (1-9) Key scan controller
The Key scan controller controls to input from external Key data.
 - (1-10) Key data buffer
The data buffer for key stores Key data until next key data is stored.
 - (1-11) CR Oscillator
The Oscillator is external connect resistor, which generates the master clock.
 - (1-12) Reset circuit
The Reset circuit is type of detectable voltage. It resets internal circuit when the power turns on or drop the voltage.

Fig.1 Display data RAM (DDRAM) Map

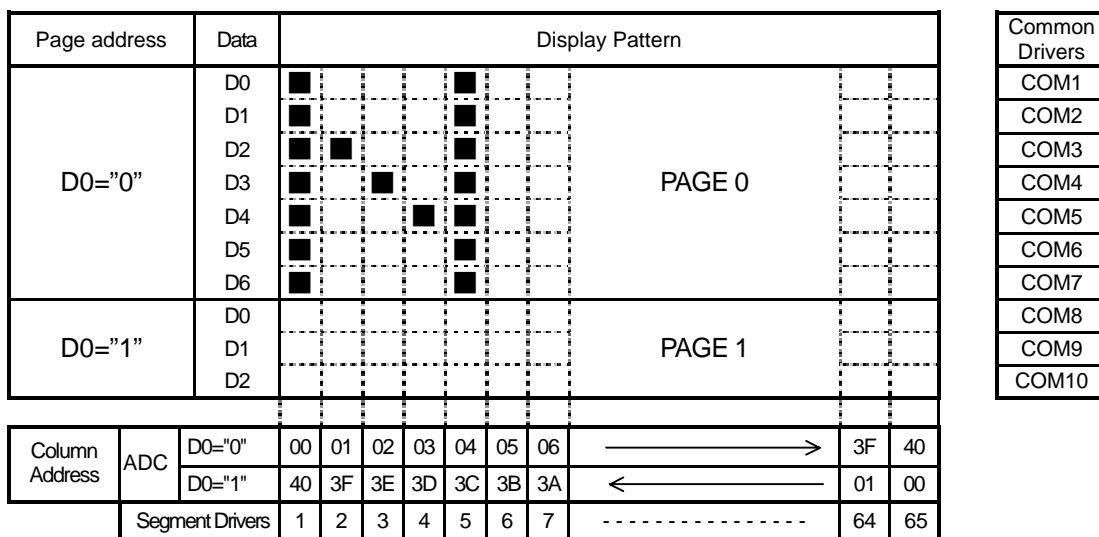

- (2) Instruction
 3-wired Serial I/F is clock synchronized of the SCL clock. and D₇ to D₀ signal select data or instruction by A0 signal.
 The data input as MSB(D7) first serially.

Table 1. Instruction Code (*: Don't Care)

Instruction		Code									Description
		A0	D ₇	D ₆	D ₅	D ₄	D ₃	D ₂	D ₁	D ₀	
(a)	Display ON/OFF	0	1	0	1	0	1	1	1	0/1	LCD display ON / OFF D ₀ =0 : OFF, D ₀ =1 : ON
(b)	Page address set	0	1	0	1	1	0	0	0	0/1	Set the page of DDRAM to the page address register. D ₀ =0 : PAGE 0, D ₀ =1 : PAGE 1
(c)	Column address set Higher order 3-bits	0	0	0	0	1	*	Higher order Column add.		Set the Higher order 3 bits column address to the register.	
	Column address set Lower order 4-bits	0	0	0	0	0	Lower order Column add.		Set the Lower order 4 bits column address to the register.		
(d)	Display data write	1	*	Write data						Write the data into the Display data RAM(DDRAM)	
(e)	ADC select	0	1	0	1	0	0	0	0	0/1	Set the DDRAM to SEG driver D ₀ =0 : Normal, D ₀ =1 : Inverse
(f)	Inverse display On / Off	0	1	0	1	0	0	1	1	0/1	Inverse LCD display ON / OFF D ₀ =0 : Normal, D ₀ =1 : Inverse
(g)	Whole display ON / Normal display	0	1	0	1	0	0	1	0	0/1	Whole Display turn ON D ₀ =0: Normal, D ₀ =1: Whole Display
(h)	Reset	0	1	1	1	0	0	0	1	0	Initialize the internal circuit
(i)	E.V.R. Register Set	0	0	0	1	0	E.V.R. data			Set the Contrast control E.V.R. (16 steps)	
(j)	Duty select	0	0	0	1	1	0	Duty		Duty set (1/8,1/9,1/10) (D ₂ ,D ₁ ,D ₀)=(0,0,0) : 1/8Duty (D ₂ ,D ₁ ,D ₀)=(0,0,1) : 1/9 Duty (D ₂ ,D ₁ ,D ₀)=(0,1,0) : 1/10 Duty	
(k)	Power save mode set	0	0	1	0	0	0	0	Power save		Set the Power save mode (D ₁ ,D ₀)=(0,0) : Normal (D ₁ ,D ₀)=(0,1) : Power save 1 (D ₁ ,D ₀)=(1,0) : Power save 2 (D ₁ ,D ₀)=(1,1) : Power save 3
(l)	General output port PWM phase / frequency set	0	0	1	0	1	0	0	Phase	Freq.	Set the PWM phase / frequency D ₁ : PWM Phase set D ₀ : PWM Frequency set
(m)	General output port select	0	0	1	1	0	0	0	Port		Select the General output port for PWM level set
	General output port PWM set High order 3-bits / PWM enable set	0	1	0	0	0	PWMEN	High order PWM data		PWMEN=0:"L" output PWMEN=1:PWM output Set the Higher order 3 bits PWM data to the register.	
	General output port PWM set Lower order 4-bits	0	0	1	1	1	Lower order PWM data		Set the Lower order 4 bits PWM data to the register.		
(n)	General output port / Key scan output select	0	1	0	0	1	0	0	0	0/1	Select General output port or Key scan output select by Po3/S ₀ terminal D ₀ =0 : General output port D ₀ =1 : Key scan output
(o)	Maker test	0	1	1	1	1	Test data			Do not use this instruction.	

(2-1) Instruction discription

(a) Display ON / OFF

This instruction selects display turn-on or turn-off regardless of the contents of the DDRAM.

A0	D ₇	D ₆	D ₅	D ₄	D ₃	D ₂	D ₁	D ₀
0	1	0	1	0	1	1	1	D

D 0: Display OFF
1: Display ON

(b) Page address set

In order to access to the DDRAM for writing or reading display data, both “page address set” and “column address set” instructions are required before accessing.

The page address “0” should be used for icon display because the only D₀ to D₆ is valid.

The page address “1” should be used for icon display because the only D₀ to D₂ is valid.

A0	D ₇	D ₆	D ₅	D ₄	D ₃	D ₂	D ₁	D ₀
0	1	0	1	1	0	0	0	A ₀

A ₀	Page
0	0
1	1

(c) Column address set

As above-mentioned, in order to access to the DDRAM for writing or reading display data, it is necessary to execute both “page address set” and “column address set” before accessing. The 8-bit column address data will be valid when both upper 3-bit and lower 4-bit data are set into the column address register.

Once the column address is set, it will automatically increment (+1) whenever the DDRAM will be accessed, so that the DDRAM will be able to be continuously accessed without “column address set” instruction.

The column address will stop increment and the page address will not be changed when the last address (40)H is addressed.

A0	D ₇	D ₆	D ₅	D ₄	D ₃	D ₂	D ₁	D ₀	
0	0	0	0	1	*	A ₆	A ₅	A ₄	Upper 4-bit
0	0	0	0	0	A ₃	A ₂	A ₁	A ₀	Lower 4-bit

A ₆	A ₅	A ₄	A ₃	A ₂	A ₁	A ₀	Column address (HEX)
0	0	0	0	0	0	0	00
0	0	0	0	0	0	1	01
:	:	:	:	:	:	:	:
:	:	:	:	:	:	:	:
1	0	0	0	0	0	0	40

(d) Display data write

This instruction writes display data into the selected column address on the DDRAM.

The column address automatically increments (+1) whenever the display data is written by this instruction, so that this instruction can be continuously issued without “column address set” instruction.

A0	D ₇	D ₆	D ₅	D ₄	D ₃	D ₂	D ₁	D ₀
1	*	Write data						

*:Don't Care

(e) ADC select

This instruction selects segment driver direction.

The correspondence between the column address and segment driver direction is shown in Fig.1.

Segment Driver Output order is inverse, when this instruction executes, therefore, the placement **NJU6538** against the LCD panel becomes easy.

A0	D ₇	D ₆	D ₅	D ₄	D ₃	D ₂	D ₁	D ₀
0	1	0	1	0	0	0	0	D

D 0: Clockwise Output(Normal) S₁ →S₆₅
 1: Counterclockwise Output(Inverse) S₆₅ →S₁

(f) Inverse display ON / OFF

This instruction inverses the status of turn-on or turn-off of entire LCD pixels. It doesn't change the contents of the DDRAM.

A0	D ₇	D ₆	D ₅	D ₄	D ₃	D ₂	D ₁	D ₀
0	1	0	1	0	0	1	1	D

D 0: Normal RAM data “1” correspond to “On”
 1: Inverse RAM data “0” correspond to “On”

(g) Whole display ON

This instruction turns on entire LCD pixels regardless the contents of the DDRAM. It doesn't change the contents of DDRAM. This instruction executed prior to the “Normal or Inverse display On/Off Set” Instruction.

A0	D ₇	D ₆	D ₅	D ₄	D ₃	D ₂	D ₁	D ₀
0	1	0	1	0	0	1	0	D

D 0: Normal Display (Whole display OFF)
 1: Whole Display turns On (Whole display ON)

(h) Reset

This instruction reset the LSI to the following status, however it doesn't change the contents of the DDRAM. Please be careful that it can't be substituted for the reset operation by using of the RESb terminal.

Reset status by "reset" instruction:

1. Page address : (0) page
2. Column address : (00)_H
3. EVR register : (D₃, D₂, D₁, D₀ = "1, 1, 1, 1")
4. Duty select : 1/10 Duty
5. General output port(Po0 to Po3) PWM phase / frequency (D₁, D₀ = "0, 0")
6. General output port(Po0 to Po3) PWMEN=0,
PWM value (PWM₆, PWM₅, PWM₄, PWM₃, PWM₂, PWM₁, PWM₀ = "0, 0, 0, 0, 0, 0")
7. Set the General output port (Po3) by Po3/S0 terminal

The DDRAM is not affected by this initialization.

A0	D ₇	D ₆	D ₅	D ₄	D ₃	D ₂	D ₁	D ₀
0	1	1	1	0	0	0	1	0

(i) EVR register set

E.V.R. register set instruction adjusts the contrast of the LCD, and selects. One LCD driving voltage VLCD out of 16 voltage-stages by setting E.V.R. register. Set the binary code "0000" when contrast adjustment is unused.

A0	D ₇	D ₆	D ₅	D ₄	D ₃	D ₂	D ₁	D ₀
0	0	0	1	0	E.V.R. data			

D ₃	D ₂	D ₁	D ₀	V _{LCD2} terminal level (Typical)
0	0	0	0	V _{LCD1}
0	0	0	1	0.984V _{LCD1}
0	0	1	0	0.968V _{LCD1}
0	0	1	1	0.952V _{LCD1}
0	1	0	0	0.938V _{LCD1}
0	1	0	1	0.923V _{LCD1}
0	1	1	0	0.909V _{LCD1}
0	1	1	1	0.896V _{LCD1}
1	0	0	0	0.882V _{LCD1}
1	0	0	1	0.870V _{LCD1}
1	0	1	0	0.857V _{LCD1}
1	0	1	1	0.845V _{LCD1}
1	1	0	0	0.833V _{LCD1}
1	1	0	1	0.822V _{LCD1}
1	1	1	0	0.811V _{LCD1}
1	1	1	1	0.800V _{LCD1}

(j) Duty select

Duty select instruction is which sets LCD driving duty ratio 1/8 or 1/9 or 1/10 duty.

A0	D ₇	D ₆	D ₅	D ₄	D ₃	D ₂	D ₁	D ₀
0	0	0	1	1	0	Duty		

D ₂	D ₁	D ₀	Duty ratio	Scan Common
0	0	0	1/8 Duty	COM1 to COM8 (5x7 character + 1-icon)
0	0	1	1/9 Duty	COM1 to COM9 (5x7 character + 2-icon)
0	1	0	1/10 Duty	COM1 to COM10 (5x7 character + 3-icon)

(k) Power save mode set

Power save mode reduces the operating current of application using Display Off and selects a terminal condition of Key scan signal output. The terminal, which is set to "L", does not output Key scan signal as shown in following table.

A0	D ₇	D ₆	D ₅	D ₄	D ₃	D ₂	D ₁	D ₀
0	0	1	0	0	0	0	Power save	

D ₁	D ₀	Function	Internal OSC.	LCD output	Key scanning output terminals states *1				
					S ₀	S ₁	S ₂	S ₃	S ₄
0	0	Normal	ON	ON	H	H	H	H	H
0	1	Power save 1	Stop	Display Off	L	L	L	L	H
1	0	Power save 2	Stop	Display Off	L	L	L	H	H
1	1	Power save 3	Stop	Display Off	H	H	H	H	H

*1 No scanning states.

(l) General output port PWM phase / frequency set

General output port PWM phase / frequency set instruction setting PWM phase and PWM frequency.

A0	D ₇	D ₆	D ₅	D ₄	D ₃	D ₂	D ₁	D ₀
0	0	1	0	1	0	0	Phase	Frequency

D ₁	General Output Port PWM phase set
0	32-steps shift phase PWM output timing by Po0 to Po1, Po1 to Po2, Po2 to Po3.
1	same phase PWM output timing by Po0 to Po3.

D ₀	General Output Port PWM frequency set
0	f _{sys} / 128 frequency. (Default)
1	f _{sys} / 256 frequency.

(f_{sys} : system clock = f_{osc} / 2)

(m) General output port set.

This instruction sets the PWM value outputted from Po0 ~ Po3 terminals. The "General output port select" instruction selects the general output port to output with PWM. The "General output port PWM set" instruction sets the PWM value.

The "General output port select instruction" and the "General output port PWM set instruction" is not necessary to continuously perform. Because these instructions are independently.

1. General output port select.

This instruction selects the general output port to output with PWM.

A0	D ₇	D ₆	D ₅	D ₄	D ₃	D ₂	D ₁	D ₀
0	0	1	1	0	0	0	Port	

D ₁	D ₀	Port
0	0	Po0
0	1	Po1
1	0	Po2
1	1	Po3

2. General output port PWM set

This instruction sets the PWM value outputted from Po0 ~ Po3 terminals.

The PWM output setting is available for 128-step at each port output terminals.

A0	D ₇	D ₆	D ₅	D ₄	D ₃	D ₂	D ₁	D ₀
0	1	0	0	0	PWMEN	PWM ₆	PWM ₅	PWM ₄
0	0	1	1	1	PWM ₃	PWM ₂	PWM ₁	PWM ₀

A) PWMEN

0: Selected general output port is "L" output.

1: Selected general output port outputs PWM depending on PWM data.

B) PWM₆ to PWM₀

PWM value: This register sets the duty value of PWM outputted from the selected general output port.

The PWM value set requires twice, which are upper 3-bit and lower 4-bit.

The PWM duty is $(\text{Register} + 1) / 128$.

(*:Don't Care)

PWMEN	PWM ₆	PWM ₅	PWM ₄	PWM ₃	PWM ₂	PWM ₁	PWM ₀	PWM DUTY	PWMEN	PWM ₆	PWM ₅	PWM ₄	PWM ₃	PWM ₂	PWM ₁	PWM ₀	PWM DUTY
0	*	*	*	*	*	*	*	0/128									
	0	0	0	0	0	0	0	1/128		1	0	0	0	0	0	0	65/128
	0	0	0	0	0	0	0	2/128		1	0	0	0	0	1	0	66/128
	0	0	0	0	0	0	1	3/128		1	0	0	0	0	1	0	67/128
	0	0	0	0	0	1	0	4/128		1	0	0	0	0	1	1	68/128
	0	0	0	0	0	1	1	5/128		1	0	0	0	1	0	0	69/128
	0	0	0	0	1	0	0	6/128		1	0	0	0	1	0	1	70/128
	0	0	0	0	1	0	1	7/128		1	0	0	0	1	1	0	71/128
	0	0	0	0	1	1	0	8/128		1	0	0	0	1	1	1	72/128
	0	0	0	1	0	0	0	9/128		1	0	0	1	0	0	0	73/128
	0	0	0	1	0	0	1	10/128		1	0	0	1	0	1	0	74/128
	0	0	0	1	0	1	0	11/128		1	0	0	1	0	1	1	75/128
	0	0	0	1	0	1	1	12/128		1	0	0	1	1	0	0	76/128
	0	0	0	1	1	0	0	13/128		1	0	0	1	1	0	1	77/128
	0	0	0	1	1	0	1	14/128		1	0	0	1	1	0	1	78/128
	0	0	0	1	1	1	0	15/128		1	0	0	1	1	1	0	79/128
	0	0	0	1	1	1	1	16/128		1	0	0	1	1	1	1	80/128
	0	0	1	0	0	0	0	17/128		1	0	1	0	0	0	0	81/128
	0	0	1	0	0	0	1	18/128		1	0	1	0	0	1	0	82/128
	0	0	1	0	0	1	0	19/128		1	0	1	0	0	1	1	83/128
	0	0	1	0	0	1	1	20/128		1	0	1	0	1	0	0	84/128
	0	0	1	0	1	0	0	21/128		1	0	1	0	1	0	1	85/128
	0	0	1	0	1	0	1	22/128		1	0	1	0	1	1	0	86/128
	0	0	1	0	1	1	0	23/128		1	0	1	0	1	1	1	87/128
	0	0	1	0	1	1	1	24/128		1	0	1	1	0	0	0	88/128
	0	0	1	1	0	0	0	25/128		1	0	1	1	0	0	1	89/128
	0	0	1	1	0	0	1	26/128		1	0	1	1	0	1	0	90/128
	0	0	1	1	0	1	0	27/128		1	0	1	1	0	1	1	91/128
	0	0	1	1	0	1	1	28/128		1	0	1	1	1	0	0	92/128
	0	0	1	1	1	0	0	29/128		1	0	1	1	1	0	1	93/128
	0	0	1	1	1	0	1	30/128		1	0	1	1	1	1	0	94/128
	0	0	1	1	1	1	0	31/128		1	0	1	1	1	1	1	95/128
	0	0	1	1	1	1	1	32/128	1	1	1	0	0	0	0	0	96/128
	0	1	0	0	0	0	0	33/128		1	1	0	0	0	0	1	97/128
	0	1	0	0	0	0	1	34/128		1	1	0	0	0	1	0	98/128
	0	1	0	0	0	1	0	35/128		1	1	0	0	0	1	1	99/128
	0	1	0	0	0	1	1	36/128		1	1	0	0	1	0	0	100/128
	0	1	0	0	1	0	0	37/128		1	1	0	0	1	0	1	101/128
	0	1	0	0	1	0	1	38/128		1	1	0	0	1	1	0	102/128
	0	1	0	0	1	1	0	39/128		1	1	0	0	1	1	1	103/128
	0	1	0	0	1	1	1	40/128		1	1	0	0	1	1	1	104/128
	0	1	0	1	0	0	0	41/128		1	1	0	1	0	0	0	105/128
	0	1	0	1	0	0	1	42/128		1	1	0	1	0	1	0	106/128
	0	1	0	1	0	1	0	43/128		1	1	0	1	0	1	1	107/128
	0	1	0	1	0	1	1	44/128		1	1	0	1	1	0	0	108/128
	0	1	0	1	1	0	0	45/128		1	1	0	1	1	0	1	109/128
	0	1	0	1	1	0	1	46/128		1	1	0	1	1	1	0	110/128
	0	1	0	1	1	1	0	47/128		1	1	0	1	1	1	1	111/128
	0	1	0	1	1	1	1	48/128		1	1	0	1	1	1	1	112/128
	0	1	1	0	0	0	0	49/128		1	1	1	0	0	0	0	113/128
	0	1	1	0	0	0	1	50/128		1	1	1	0	0	0	1	114/128
	0	1	1	0	0	1	0	51/128		1	1	1	0	0	1	1	115/128
	0	1	1	0	0	1	1	52/128		1	1	1	0	1	0	0	116/128
	0	1	1	0	1	0	0	53/128		1	1	1	0	1	0	1	117/128
	0	1	1	0	1	0	1	54/128		1	1	1	0	1	1	0	118/128
	0	1	1	0	1	1	0	55/128		1	1	1	0	1	1	1	119/128
	0	1	1	0	1	1	1	56/128		1	1	1	1	0	0	0	120/128
	0	1	1	1	0	0	0	57/128		1	1	1	1	0	0	1	121/128
	0	1	1	1	0	0	1	58/128		1	1	1	1	0	1	0	122/128
	0	1	1	1	0	1	0	59/128		1	1	1	1	0	1	1	123/128
	0	1	1	1	0	1	1	60/128		1	1	1	1	1	0	0	124/128
	0	1	1	1	1	0	0	61/128		1	1	1	1	1	0	1	125/128
	0	1	1	1	1	0	1	62/128		1	1	1	1	1	1	0	126/128
	0	1	1	1	1	1	0	63/128		1	1	1	1	1	1	1	127/128
	0	1	1	1	1	1	1	64/128		1	1	1	1	1	1	1	128/128

Example) Set output PWM waveform of Po0 to Po3 terminal, shown below:

- PWM phase set $D_1=0$,
- $PWMEN=1$,
- $(PWM_6, PWM_5, PWM_4, PWM_3, PWM_2, PWM_1, PWM_0)=(1,0,0,0,0,0,0)$

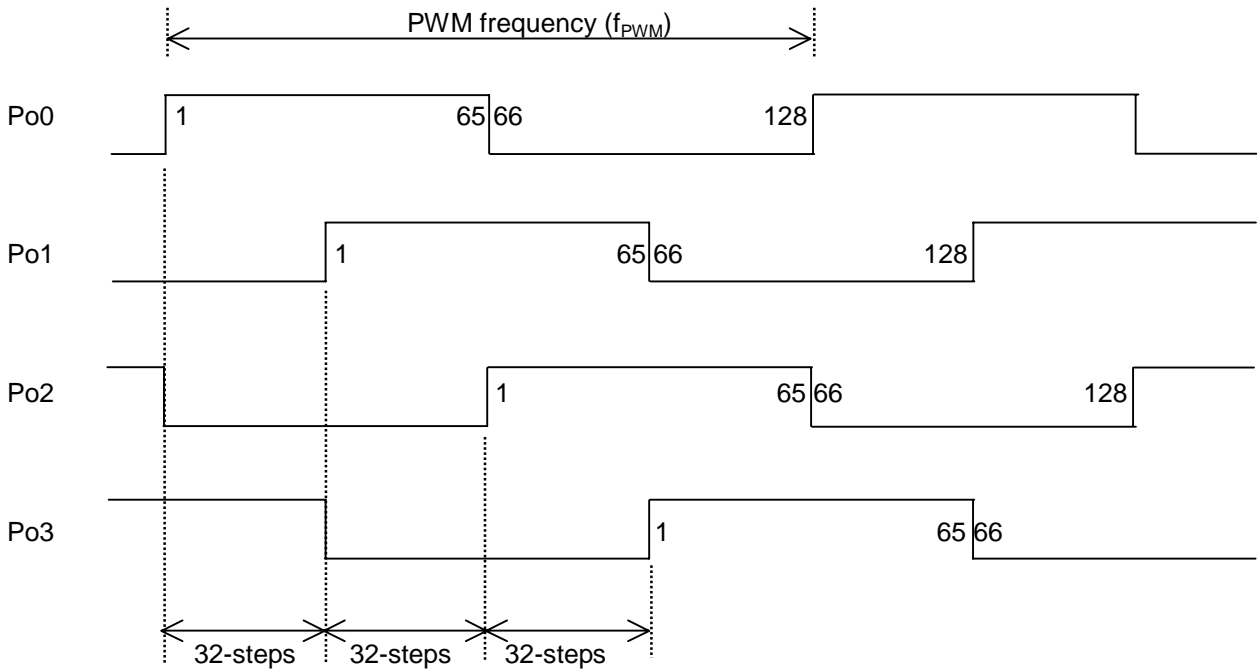

(n) General output port / Key scan output select

This instruction assigns function of general purpose output port or key scan output to Po3/S0 terminals.

A0	D ₇	D ₆	D ₅	D ₄	D ₃	D ₂	D ₁	D ₀
0	1	0	0	1	0	0	0	D

- D 0: General output port
 1: Keyscan output

(3) Input Data Format and Timing

Data format is shown below.

When the CE terminal goes to "L", I/F is data output.

When the CE terminal goes to "H" (rising edge) at SCL terminal "H", I/F is data input.

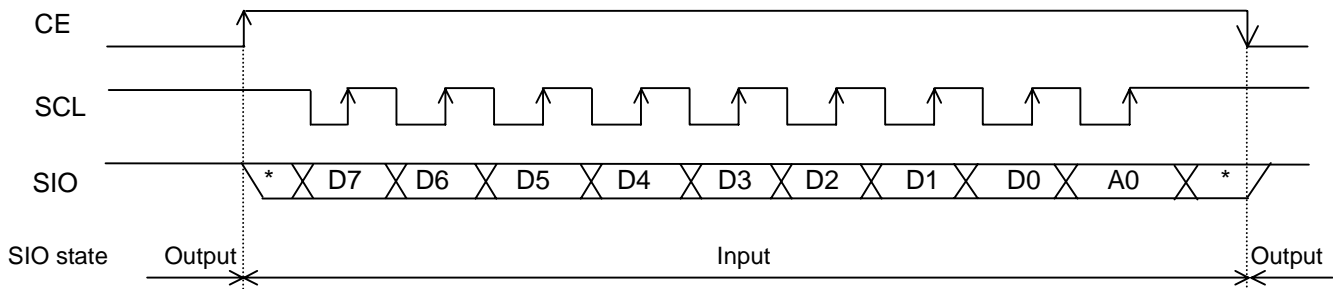

NOTE1) Data fetched at SCL rising edge.

NOTE2) A contents change of the instruction and data which were written is fetched by the 9th rising edge of SCL.

NOTE3) When the instruction and data which were written are less than 9-bit, they are ignored and is not fetched.

NOTE4) When the instruction and data which were written are over 9-bit, the last 9-bit is valid.

(4) Power save mode set

Power save mode is set by "Power save mode set" instruction. The segment and common output "L" is outputted, the OSC terminal halts an oscillation (it oscillates at the time of key-on), and consumption current is decreased.

Power save mode is canceled, when normally set by "Power save mode set" instruction.

(5) Key scan circuit

Key scan circuit connects the 5 x 5 key-matrix maximum and reads the data of 25 keys maximum. It chooses the number of keys in key-matrix by "General output port / key scan output select" instruction.

It outputs a identified key data to MPU after comparison with two data read from the key-matrix in twice for reliable key operation. If those data are not identified, key data is not outputted. It outputs "L" signal through "SO" terminal as the request after 332T[s] ($T=1/f_{sys}=2/f_{osc}$, f_{sys} : Internal system clock frequency) when any key is operated. Furthermore, the key scan circuit structures for reducing the external components like as Diodes to prevent circuit short problem.

(5-1) The relation between output data and key matrix

The relation between output data and key matrix shows bellow table and sets "1" signal for operated key.

In case of 20 keys application, unassigned area for keys from KD1 to KD5 in bellow table take "0" signal.

In mode of Power save 1, area for keys from KD1 to KD20 in bellow table take "0" signal. In mode of Power save 2, area from KD1 to KD15 take "0" signal also. The terminals, which are not connected any keys, should be open.

	K ₀	K ₁	K ₂	K ₃	K ₄
S ₀	KD1	KD2	KD3	KD4	KD5
S ₁	KD6	KD7	KD8	KD9	KD10
S ₂	KD11	KD12	KD13	KD14	KD15
S ₃	KD16	KD17	KD18	KD19	KD20
S ₄	KD21	KD22	KD23	KD24	KD25

(5-2) Data output timing

The data output format shows bellow. The data output mode is set by "L" status of SCL terminal at the rising signal of CE terminal.

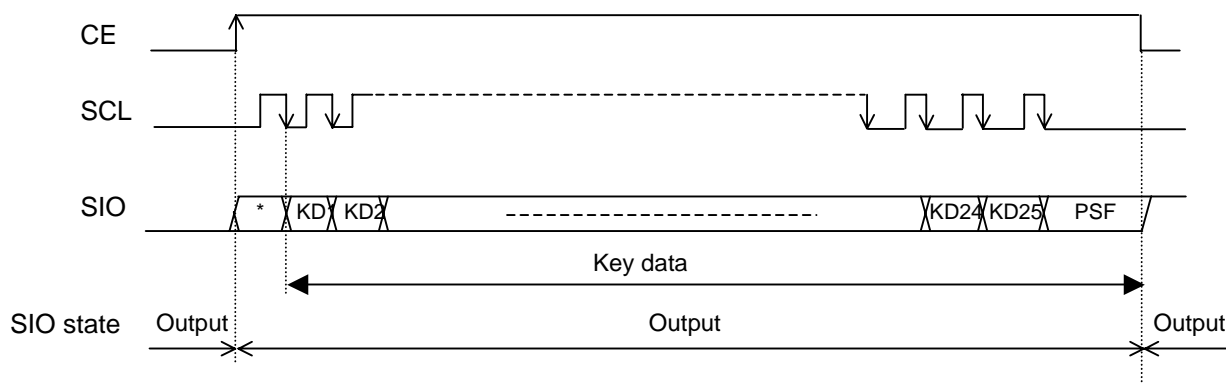

(5-3) Power save flag (PSF)

The status of Power save flag is outputted after KD25 in Key data reading. This flag sets "1" signal in mode of Power save in Key data reading and sets "0" in mode of Normal.

(5-4) Timing of Key scan

Key scan cycle is $160T[S]$ ($T=1/f_{sys}=2/f_{osc}$, f_{sys} : Internal system clock frequency). The data of key scan is a result of comparison with a couple of Key scan for correct judge whether Key On or Off. When the result of comparison is correct (accord), the **NJU6538** recognizes Key On and outputs "L" level from SIO terminal after $322T[S]$ from start of Key scan for a request to read key data out to external MPU. When the SIO terminals outputs "L" signal, the key scan does not operate until end of key data reading by MPU, and scanned key data is kept. When the result of comparison is incorrect (not accord), Key scan operates again if any key is On. Therefore, Key scan may operate incorrectly in case of shorter period of Key on than $322T[S]$

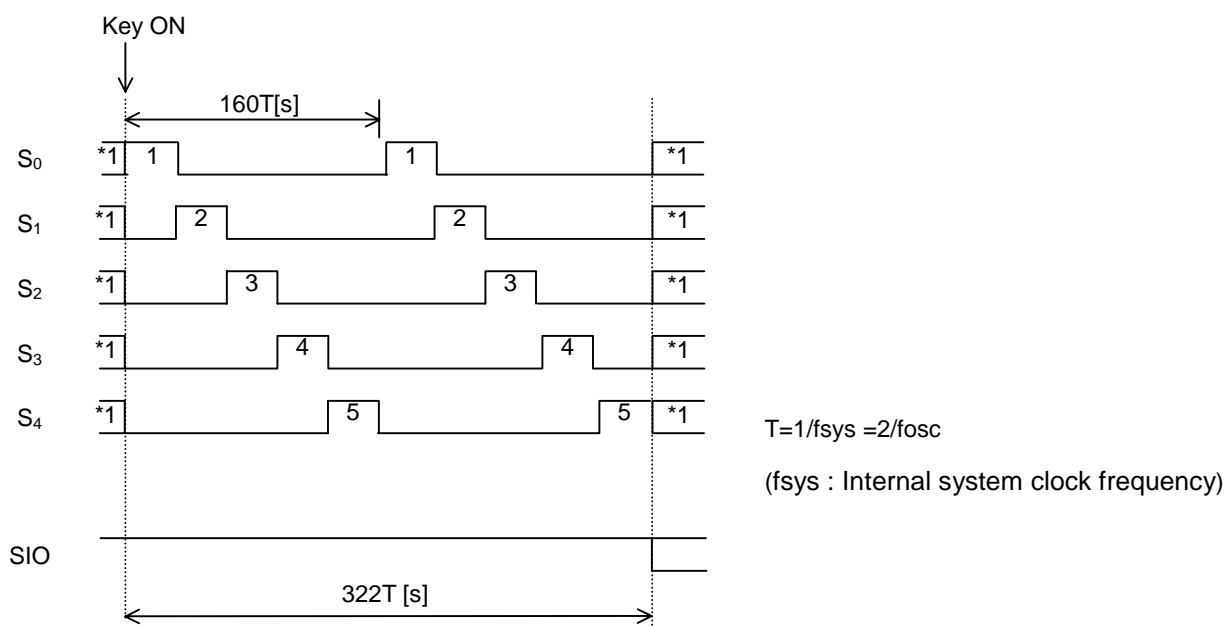

*1 Instruction set the General output ports or output the Key scan signals (refer (1)Instruction (n)General output port / Key scan select)

Key scan cycle and the timing of Key data read out request are constant in any Power save mode.

(5-5) Normal mode

Key scan operates with follows in normal mode.

- 1, Key scan signal output terminals S0 – S4 output “H” signals when key scan does not operate, and output key scan signals after start of key scan operation. The conditions of key scan signal input terminals K0 – K4 are “L” state with internal pull-down resistances, though “H” signal comes in to K0 – K4 corresponding to the turned on keys.
- 2, The function of key scan starts twice operations when any key is turned on. It stops when a couple of data by continuously twice key scan operations are accorded and fixed as a correct key status. It operates more 2 times when the key status is not fixed and any keys are still turning on. It repeats again and again until key status is fixed. The correct key status data is stored and newly key scan operation does not start until external MPU reads data out after key status is fixed.
- 3, When the key status is fixed, SO terminal outputs “L” signal as Key data read out request to MPU. MPU should read key data out at detection of this “L” signal.
- 4, The Key data read out request signal is released and SO terminal outputs “H” signal after finish of MPU key data read out for newly key scan operation.

SIO terminal requires pull up resistor because of Open drain type output. Multiple data of key are output in case of key more input so that MPU should process the data by itself.

Key scan example (Normal mode)

$T = 1 / f_{osc}$

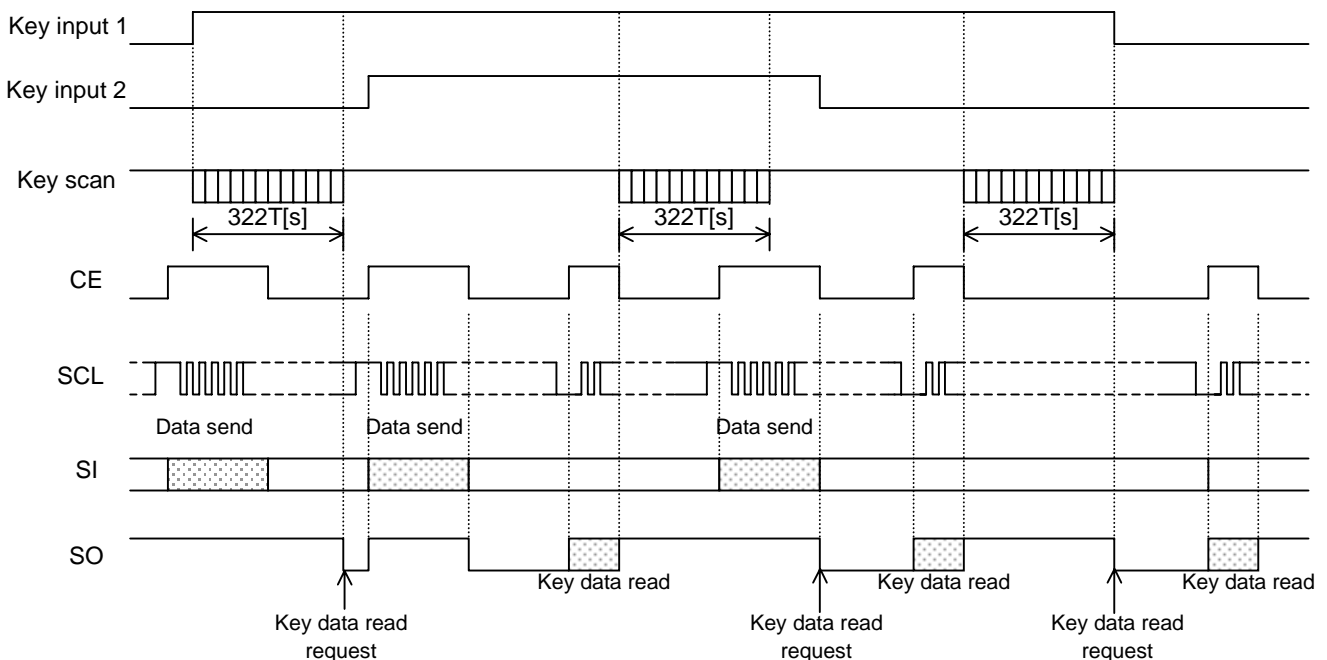

(5-6) Power save mode

Key scan operates with follows in Power save mode.

- 1, Key scan signal output terminals S0 – S4 output “H”, “L” signals by the Power save mode set when key scan does not operate (refer the detail of instructions), and output key scan signals after start of key scan operation. The conditions of key scan signal input terminals K0 – K4 are “L” state with internal pull-down resistances, though “H” signal comes in to K0 – K4 corresponding to the turned on keys.
- 2, The oscillation circuit function of key scan starts twice operations when any keys on cross points with S0– S4 terminals line and K0 – K4 turned on. It stops when a couple of data by continuously twice key scan operations are accorded and fixed as a correct key status. It operates more 2 times when the key status is not fixed and any keys are still turning on. It repeats again and again until key status is fixed. The correct key status data is stored and newly key scan operation does not start until external MPU reads data out after key status is fixed.
- 3, When the key status is fixed, SIO terminal outputs “L” signal as Key data read out request to MPU. MPU should read key data out at detection of this “L” signal.
- 4, The Key data read out request signal is released and SIO terminal outputs “H” signal after finish of MPU key data read out for newly key scan operation. Although Power save mode is not released.

SIO terminal requires pull up resistor because of Open drain type output. Multiple data of key are output in case of key more input so that MPU should process the data by itself.

Key scan example (Power save mode)
Ex.) D0= "0", D1= "1" (K4="H" power save)

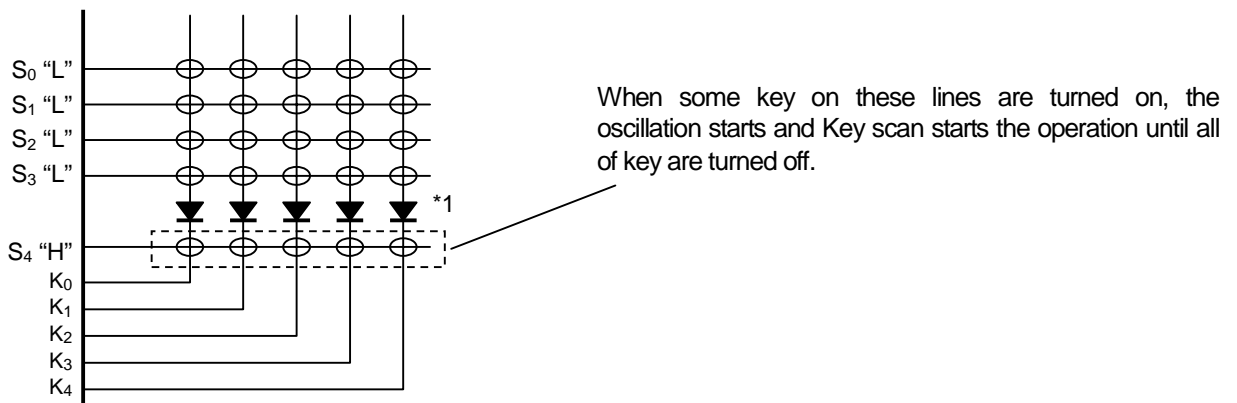

*1 These diodes are required to recognize key more input of keys on the K4 line when only K4 terminal outputs “H” signal in power save mode as shown above example. In case of no diodes, incorrect key data may read out sometimes by key more input of keys on lines of K0 to K4.

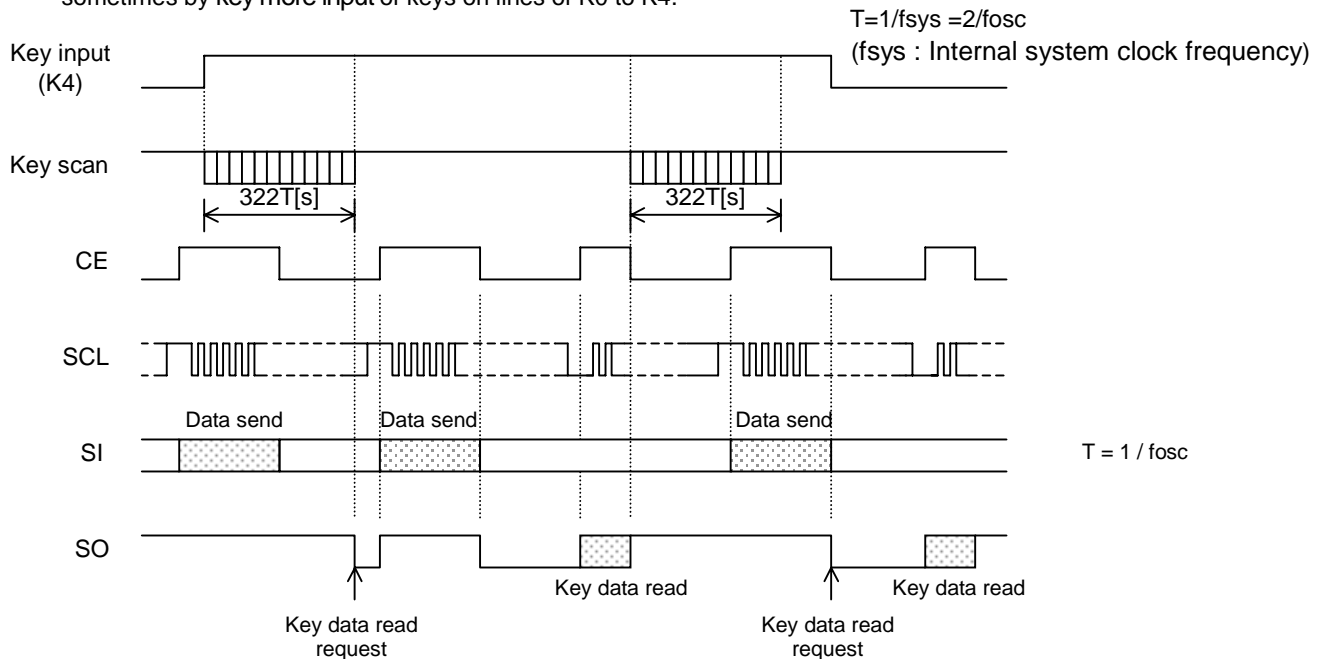

(5-7) Key More Input

Key scan signal output terminal S0 to S4 output "H" level in state of Key More Input. Although Key state is detected without diodes to prevent unexpected key scan signal flow, non-pressed key data may change pressed key data in triple or more key Input as shown in Fig. 1 and incorrect key data may be output to external MPU. For prevention of miss-recognition by incorrect key data, diodes should be inserted in front of K0 – K4 terminals as shown in Fig. 3 or control program of MPU should ignore the combination of key data miss-recognition. For example, 4 keys and more ON data should be ignored.

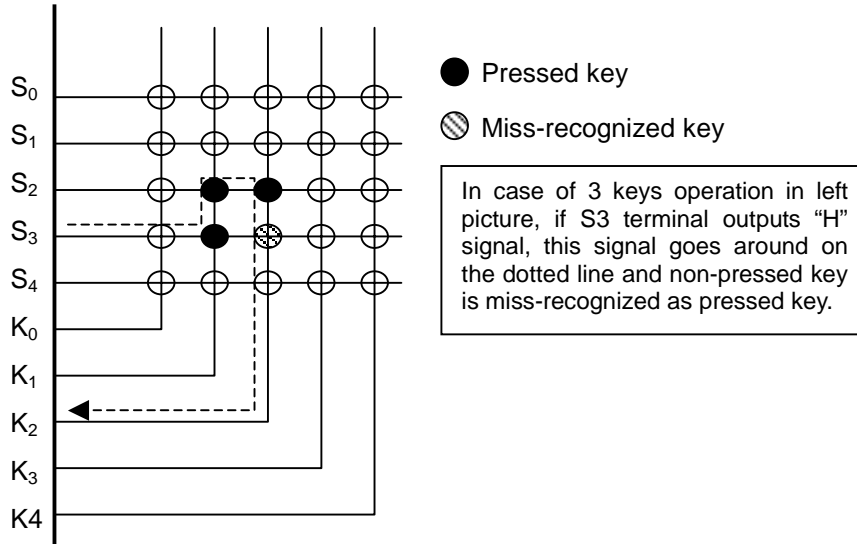

Fig. 1 Miss-recognized example by key more input

In modes of power save 1 (S0=0, S1=1 / Keys on only S5 line are valid) or power save 2 (S0=0, S1=1 / Keys on only S4 and S5 lines are valid), pay attention about the followings. When Key More Input is operated across the valid line and invalid, non-pressed key is miss-recognized as pressed key. However, Key data on the invalid line is not read out and 4 keys and more operation in the mean time are not ignored by MPU control program as shown in Fig. 2. In this case, diodes operate to prevent miss-recognition as shown in Fig. 3.

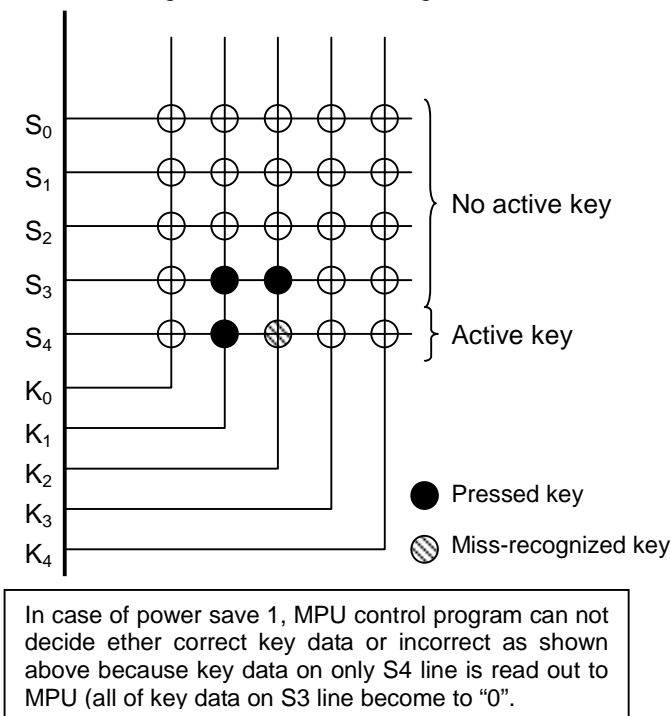

Fig. 2 Miss-recognition in power save 1

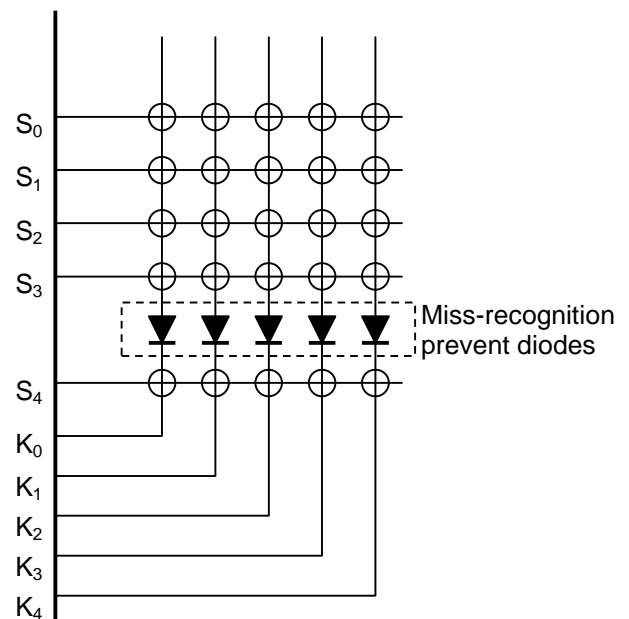

Fig. 3 Connect miss-recognition prevent diodes

(5-8) Key data reading out operation by external MPU

(a) Display data writing

Display data and an instruction change operate at the rising edge of 9-bit on SCL signal.

(b) Key data reading out operation

The minimum period from Key in to SIO terminal = "L" is $322T(t_1)$ by key scan operation. When key scan operation performs again for key data fix preventing from noise or bouncing of key, the period from Key in to SIO terminal = "L" is $676T(t_1)$. When the SIO terminal outputs "L", the key scan operation is stopped after execution of key data reading out operation. Therefore, fixed key data is kept until end of key data reading out operation. When key data reading out operation is performed during SO terminal = "H", both of key data from KD1 to KD25 and power save flag (PSF) are not outputted correctly.

Key data reading out operation example

The flowchart below shows an example of timer interrupt application. When SIO terminal condition is "L" after check of SIO terminal condition at every timer interrupt operation, it is decided as Key In and key data reading out operation is performed. When SIO terminal condition is "H", it is decided as Key Off. For the correct decision of Key Off, the timer interrupt cycle ($1/t_3$) should be expanded over the time added with [period of key scan ($676T$ in case of measure against key bouncing of key) and [period of key data reading out operation (t_2)]. In this time, the period of timer interrupt cycle (t_3) must be set with enough margins including the range of f_{osc} .

● Sequence of key data reading out operation

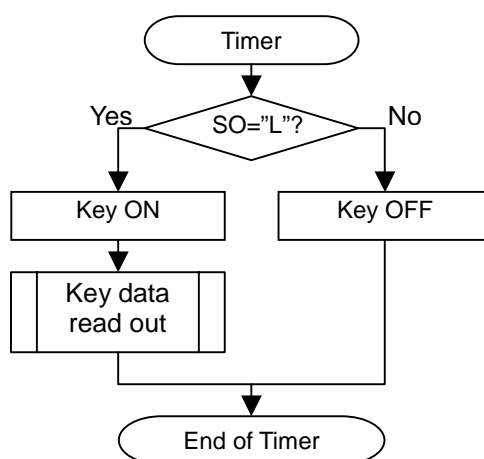

● Timing chart of key data reading out operation

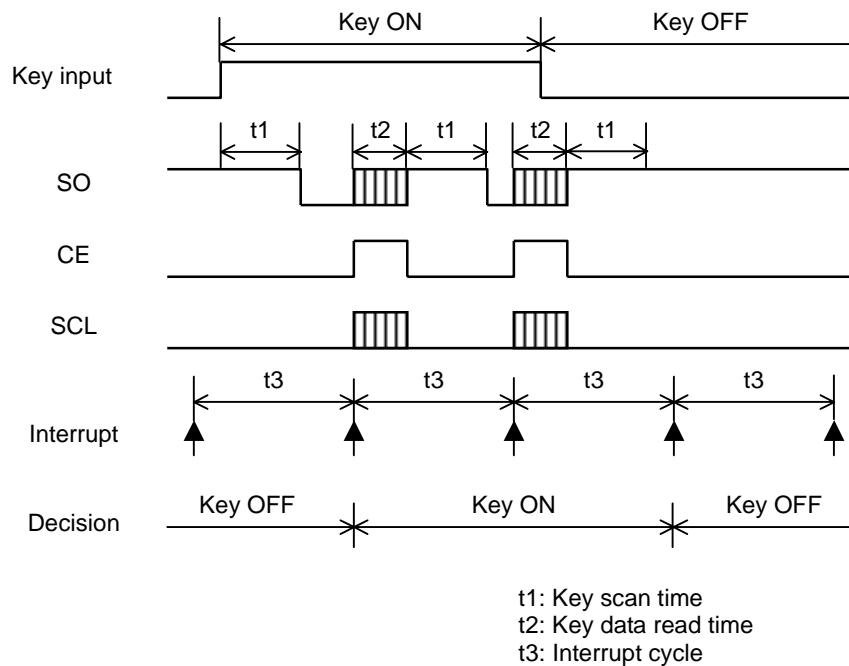

*: $t3 > t1 + t2$

(6) Reset circuit initializes

Reset circuit initializes the **NJU6538** at Power ON and OFF. It generates reset signal to initialize the system at low VDD less than power down detection voltage (2.0V typical).

(6-1) Initial status in reset

- 1, Stop the oscillation circuit
- 2, Display Off (Available Serial data transmission)
- 3, Disable Key scan function
- 4, Filled "L" data in all of key data buffer

(6-2) The status of output port terminals in Reset

Output terminals	Reset status
SEG ₁ to SEG ₆₅	L
COM ₁ to COM ₁₀	L
Po0 to Po2	L
Po3/S ₀	L*1
S ₁ to S ₄	H
SIO	H*2

*1 This terminal operates as segment driver and outputs "L".

*2 This terminal consisted of Open-drain output type circuit requires external pull-up resistor connecting to external power source for MPU. If key data read is executed in power on reset, the read data is fixed as "H".

The reset circuit initializes the LSI to the following status by using of the input 10μs(min.) or over "L" level signal into the RESb terminal. The LSI will return to normal operation after about 1.0μs(max.) from the rising edge of the rest signal. The "Reset" instruction can't be substituted for the reset operation by using of the RESb terminal. It executes above-mentioned only 7 to 13 items.

(6-3) Reset status using the RESb terminal (default)

1. Serial interface register clear
2. Display off
3. ADC select : $D_0="0"$ (Normal mode)
4. Normal Display (Non-inverse display)
5. Whole display off : $D_0="0"$ (Normal mode)
6. Power save mode : $D_1, D_0="0, 0"$ (Normal mode)
7. Page address : 0 page
8. Column address : 00_H
9. EVR register : $D_3, D_2, D_1, D_0="1, 1, 1, 1"$
10. Duty select : 1/10 Duty
11. General output port PWM phase and frequency : $D_1, D_0="0, 0"$
12. General output port : PWMEN=0 ("L" output),
PWM value : $D_6, D_5, D_4, D_3, D_2, D_1, D_0="0, 0, 0, 0, 0, 0, 0"$
13. Po3/S0 terminal : $D_0="0"$ (Po3)

(6-4) Initialization by Hardware

The **NJU6538** incorporates reset terminal to initialize the all system. When the "L" level signal input over then 10us(min.) to the RESb terminal, reset sequence is executed. In this time, internal busy during 1us after RESb terminal goes to "H".

Reset circuit

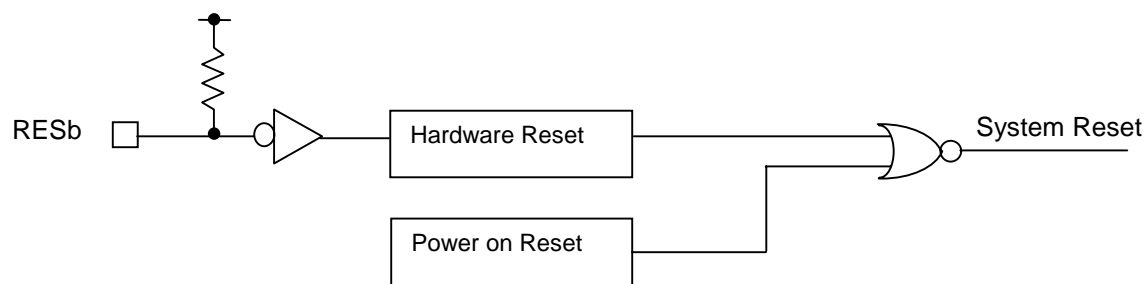

(6-5) Power on reset operation

When the voltage rising time of power source is over than 1mS, the generated signal of VDET initializes the system of **NJU6538** as reset. When the voltage falling time of power source is over than 1ms, the system is also reset.

When these voltage rising or falling time of power source are not over than 1ms, the Initialization operation as reset does not operate correctly.

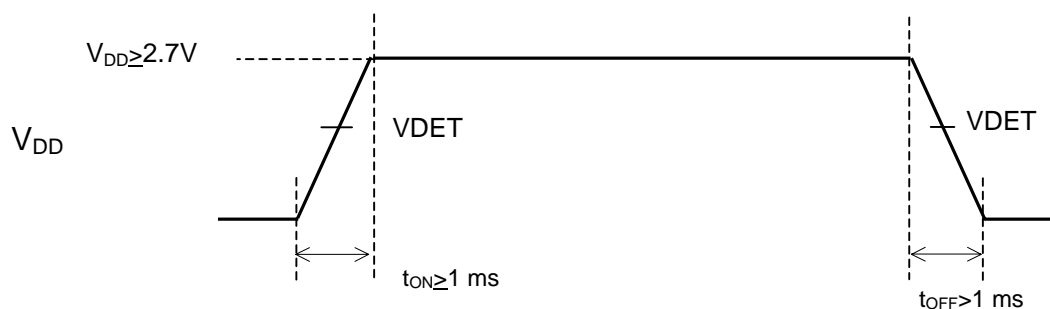

NJU6538

(7) LCD panel drive

(7-1) LCD driving voltage generation circuit

LCD driving voltage generation circuit generates LCD driving bias voltages V_{LCD2} , V_0 , V_1 and V_2 . It adjusts the voltage by 8 steps electrical volume from V_{LCD1} and allots the voltage to V_{LCD2} , V_0 , V_1 and V_2 by resistor-voltage-dividing as shown in below.

V_{LCD1} , V_{LCD2} , V_0 , V_1 and V_2 terminals requires external capacitors for bias voltage stabilization for display quality. These values of capacitors should be fixed in accordance with evaluation in the application.

Power Supply	Duty ratio	1/8, 1/9, 1/10
	Bias	1/4
V_{LCD}		$V_{LCD2} - V_{SS}$

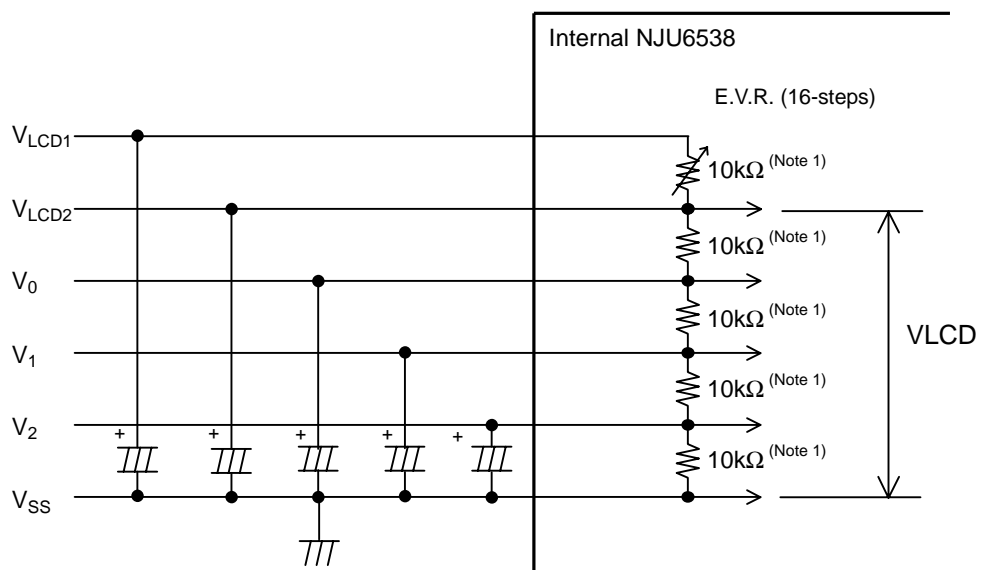

Note 1 : Resistor is typical value.

■ ABSOLUTE MAXIMUM RATINGS

Ta=25°C

PARAMETER	SYMBOL	CONDITIONS	RATINGS	UNIT
Supply voltage	VDD max	V _{DD} terminal	-0.3 to +7.0	V
	VLCD max	V _{LCD1} terminal	-0.3 to +11.0	
Input terminal voltage	V _{IN1}	OSC, K ₀ to K ₄ , CE, SCL, SIO terminal	-0.3 to VDD+0.3	V
	V _{IN2}	V _{LCD2} , V ₀ to V ₂ terminal	-0.3 to VLCD+0.3	
Output terminal voltage	V _{OUT1}	SIO terminal	-0.3 to +6.0	V
	V _{OUT2}	OSC, SEG ₁ to SEG ₆₅ , COM ₁ to COM ₁₀ , S ₁ to S ₄ , Po ₀ to Po ₂ , Po ₃ /S ₀ terminal	-0.3 to VDD+0.3	
Power dissipation	Pdmax	Ta=25°C QFP100-C2	1000	mW
		Ta=25°C QFP100-G1	700	
Storage temperature	Tstg	-	-55 to +125	°C
Operating temperature	Topr	-	-40 to +85	°C

Note 1) All voltage values are specified as V_{SS}=0V.

Note 2) If the LSI are used on condition beyond the absolute maximum rating, the LSI may be destroyed. Using LSI within electrical characteristics is strongly recommended for normal operation.

Use beyond the electric characteristics conditions will cause malfunction and poor reliability.

Note 3) Decoupling capacitor should be connected between VDD and VSS due to the stabilized operation for the voltage converter.

DC Electrical Characteristics

VDD=2.7 to 5.5V, Ta= - 40 to 85°C

PARAMETER	SYMBOL	CONDITION	MIN	TYP	MAX	UNIT	NOTE
Power supply (1)	VDD	VDD	2.7		5.5	V	
Power supply (2)	VLCD1	VLCD1	5.0		10.0		
Output voltage	VLCD2	VLCD2	4.0		VLCD1	V	
Input voltage	V0	V0	VSS	VLCD2x3/4	VLCD2	V	1
	V1	V1	VSS	VLCD2x2/4	VLCD2		
	V2	V2	VSS	VLCD2x1/4	VLCD2		
"H" level input voltage (1)	VIH(1)	K ₀ to K ₄	0.6VDD		VDD	V	
"H" level input voltage (2)	VIH(2)	SCL, SIO, CE	0.8VDD		VDD	V	
"L" level input voltage (1)	VIL(1)	K ₀ to K ₄ , SCL, SIO, CE	0		0.2VDD	V	
Hysteresis voltage	VH	SCL, SIO, CE		0.25VDD		V	
"H" level input current	I _{IH}	SCL, SIO, CE, V _{IN} = VDD			5.0	μA	
"L" level input current	I _{IL}	SCL, SIO, K ₀ to K ₄ , CE, V _{IN} = 0V	-5.0			μA	
Pull-up resistance	R _{PU}	RESb VDD=5.0V, V _{IN} = 0V	50	150	250	kΩ	
Pull-down resistance	R _{PD}	K ₀ to K ₄ , VDD=5.0V, V _{IN} = VDD	50	150	250	kΩ	
Output off-leak current	IOFFH	SIO, VO=5.5V			6.0	μA	
"H" level output voltage (1)	VOH(1)	S ₀ to S ₄	VDD=5.0V, I _o = -500μA	VDD-1.2	VDD-0.2	V	
			VDD=3.0V, I _o = -250μA	VDD-1.1	VDD-0.1		
"H" level output voltage (2)	VOH(2)	Po ₀ to Po ₃	VDD=5.0V, I _o = -10mA	VDD-1.0		V	
			VDD=3.0V, I _o = -5mA	VDD-0.6			
"L" level output voltage (1)	VOL(1)	S ₀ to S ₄	VDD=5.0V, I _o = 25μA	0.2	1.5	V	
			VDD=3.0V, I _o = 5μA	0.05	0.6		
"L" level output voltage (2)	VOL(2)	Po ₀ to Po ₃	VDD=5.0V, I _o = 10mA		1.0	V	
			VDD=3.0V, I _o = 5mA		0.6		
"L" level output voltage (3)	VOL(3)	SIO I _o = 1mA			0.5	V	
Driver ON-resistance (COM)	R _{COM}	Ta=25°C, VO=V _{LCD2} , VSS, V0, V2 ±I _d =1μA (COM terminal)			40	kΩ	2
Driver ON-resistance (SEG)	R _{SEG}	Ta=25°C, VO=V _{LCD2} , VSS, V1 ±I _d =1μA (SEG terminal)			40	kΩ	2
Oscillation Frequency	f _{OSC}	Ta=25°C, VDD=5.0V R _{OSC} =150kΩ	38	50	62	kHz	
LCD Driving voltage	V0	E.V.R. value "0,0,0,0" V _{LCD1} =8.0V	5.8	6.0	6.2	V	
	V1		3.8	4.0	4.2		
	V2		1.8	2.0	2.2		
Bleeder resistance	R _B	VLCD2-VSS, Ta=25°C		40		kΩ	
E.V.R. resistance	R _{EVR}	VLCD1-VLCD2, Ta=25°C		10		kΩ	
Power down detect voltage	VDET		0.8	1.4	2.0	V	
Reset time	Tr	RESb	1.0			μs	
Reset "L" pulse width	Trw	RESb	10.0			μs	
Operating current	IDD1	Power save mode			100	μA	
	IDD2	VDD=5.5V, Output open f _{OSC} =50kHz,			500	μA	
	ILCD1	Power save mode			5	μA	
	ILCD2	VLCD1=10.0V Output open f _{OSC} =50kHz,			1000	μA	

Note 1) The relation : VLCD1≥VLCD2≥V0≥V1≥V2≥VSS must be maintained.

Note 2) R_{COM} and R_{SEG} are the resistance values between power supply terminals (VSS, VLCD2, or V0, V1, V2) and each common terminal, and supply voltage (VSS, VLCD2, or V0, V1, V2) and each segment terminal respectively, and measured when the current I_d is flown on every common and segment terminals at a same time.

■ AC Characteristics

VDD=2.7 to 5.5V, Ta= - 40 to 85°C

PARAMETER	SYMBOL	CONDITION	MIN	TYP	MAX	UNIT	NOTE
"L" level clock pulse width	t_{WCLL}	SCL	160			ns	
"H" level clock pulse width	t_{WCLH}	SCL	160			ns	
Data setup time	t_{DS}	SCL, SIO	160			ns	
Data hold time	t_{DH}	SCL, SIO	160			ns	
CE wait time	t_{CP}	CE, SCL	160			ns	
CE setup time	t_{CS}	CE, SCL	160			ns	
CE hold time	t_{CH}	CE, SCL	160			ns	
CE "L" level width	t_{WCL}	CE	160			ns	
SIO output delay time	t_{DC}	SIO, Rpu=4.7kΩ, CL=10pF			1.5	μs	1
SIO rise time	t_{DR}	SIO, Rpu=4.7kΩ, CL=10pF			1.5	μs	
SCL rise time	t_r				15	ns	
SCL fall time	t_f				15	ns	

SO terminal is Open-Drain type output, so that the characteristics of SO terminal are changed by values of pull-up resistance Rpu and CL.

(1) Write operation

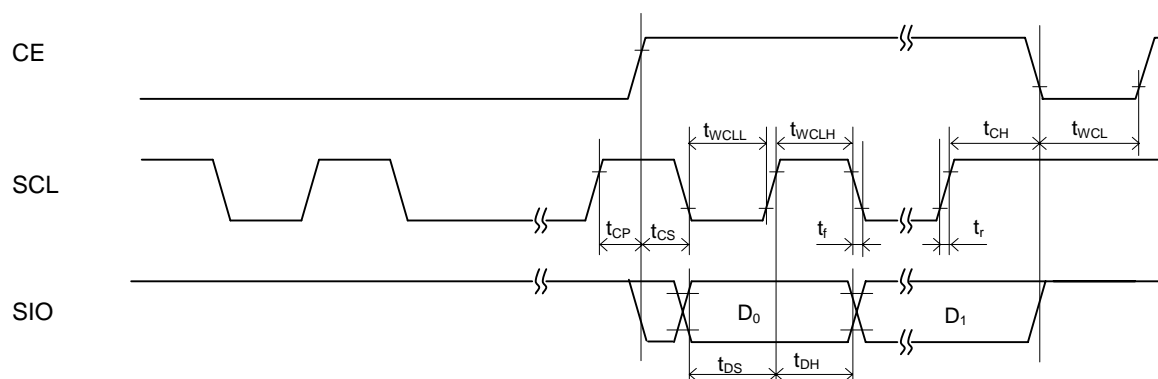

(2) Key data read operation

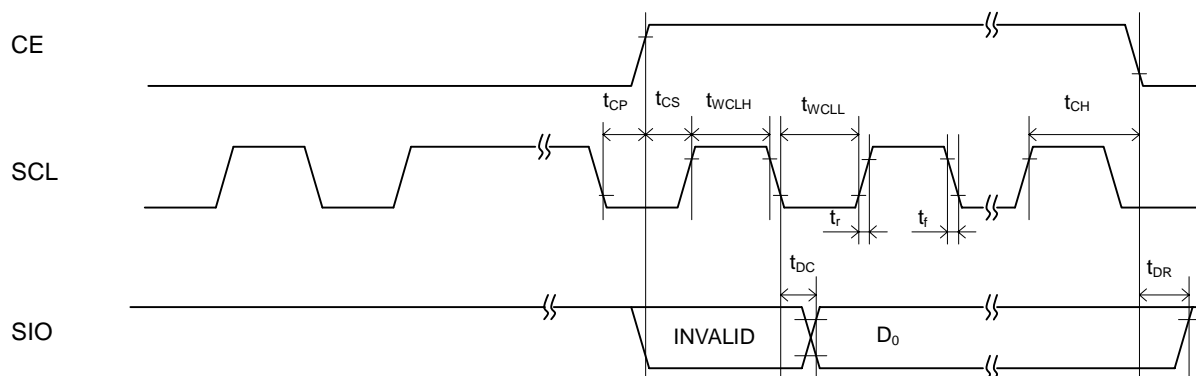

Relation between oscillation frequency and LCD frame frequency

(1) 1/8 duty

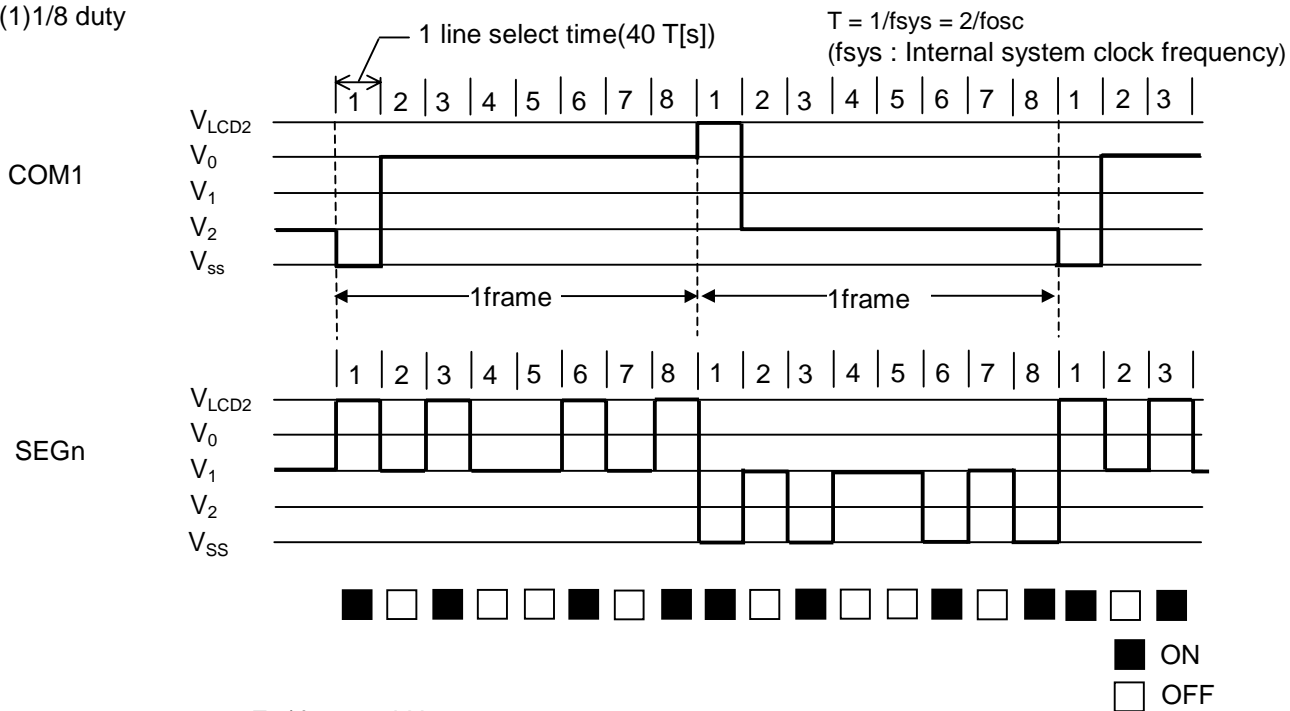

Ex.) $f_{osc}=50\text{kHz}$

Frame frequency = $1/(40T \times \text{duty}) = 1/(40 \times (2/50\text{kHz}) \times 8) = 78.1(\text{Hz})$

(2) 1/10 duty

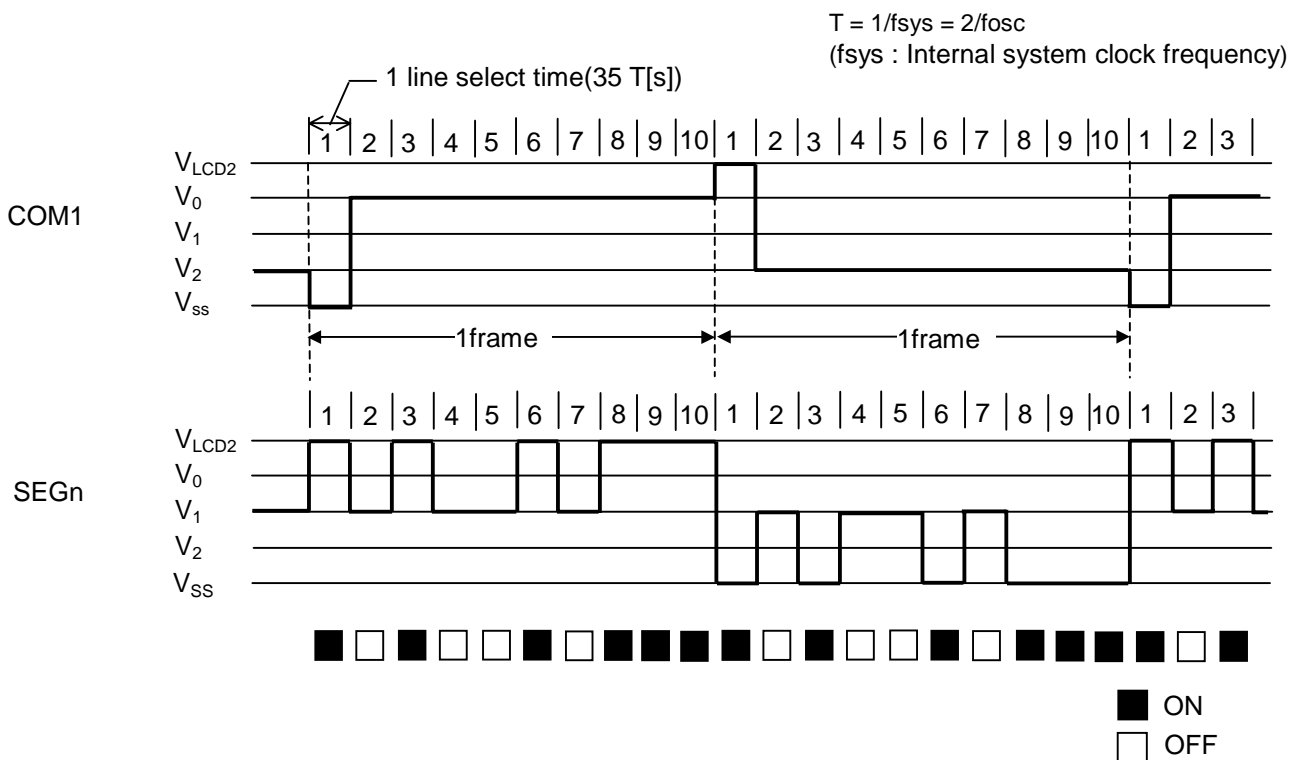

$f_{osc}=50\text{kHz}$

Frame frequency = $1/(35T \times \text{duty}) = 1/(35 \times (2/50\text{kHz}) \times 10) = 71.4(\text{Hz})$

APPLICATION CIRCUIT

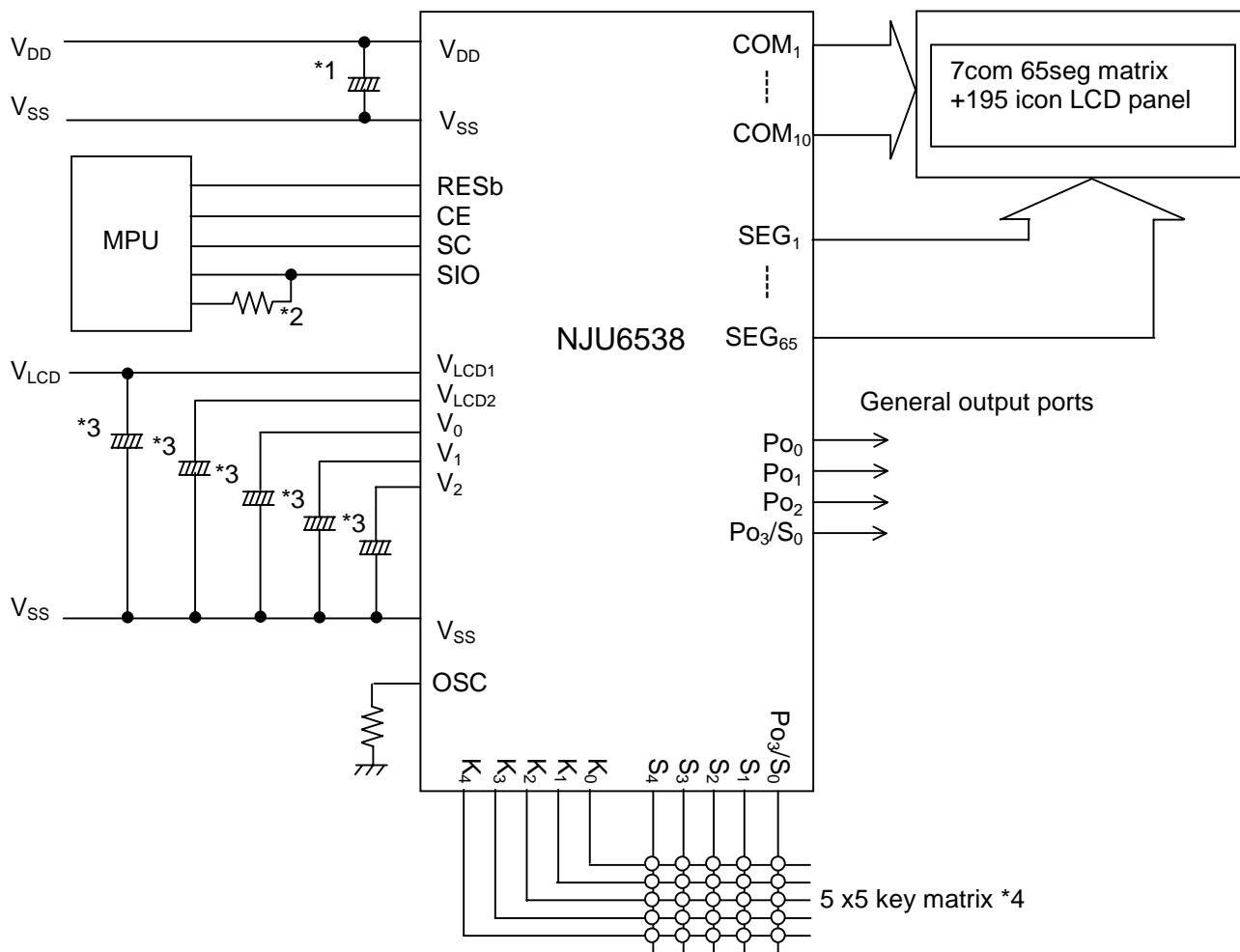

- *1 The rising time of Power source voltage at Power on and the falling time at Power off must keep over than 1ms because of Voltage detection type Reset circuit operation.
- *2 SO terminal requires external pull-up resistor connecting to Power source of external MPU because of Open-drain type output.
- *3 This capacitor for bias voltage stabilization should be connected in accordance with display quality in application.
- *4 P_{O3} / S₀ terminal is general output ports and Key scan signal output duplicated-function terminals. A function must be selected either Segment output or other.

[CAUTION]
 The specifications on this databook are only given for information, without any guarantee as regards either mistakes or omissions. The application circuits in this databook are described only to show representative usages of the product and not intended for the guarantee or permission of any right including the industrial rights.