



## Ambassador™ T8105 H.100/H.110 Interface and Time-Slot Interchanger

### Features

- Fully backwards compatible to the T8100, T8100A, and T8102 by hardware strapping and programming the DEV\_ID register
- Complete solution for interfacing board-level circuitry to the H.100/H.110 telephony bus
- Includes 2 CT\_NETREF pins
- H.100/H.110 compliant interface; all mandatory signals
- Programmable connections to any of the 4096 time slots on the H.100/H.110 bus
- Up to 16 local serial inputs and 16 local serial outputs, programmable for 2.048 Mbits/s, 4.096 Mbits/s, and 8.192 Mbits/s operation per CHI specifications
- Programmable switching between local time slots, up to 1024 connections
- Programmable switching between local time slots and H.100/H.110 bus, up to 512 connections
- Choice of frame integrity or minimum latency switching on a per-time-slot basis:
  - Frame integrity to ensure proper switching of wideband data
  - Minimum latency switching to reduce delay in voice channels
- On-chip phase-locked loop (PLL) for H.100/H.110, *MVIP*<sup>\*</sup>, or *Dialogic's*<sup>†</sup> SC-bus clock operation in master or slave clock modes
- Serial TDM bus rate and format conversion between most standard buses
- Optional 8-bit parallel input and/or 8-bit parallel output for local TDM interfaces
- High-performance microprocessor interface:
  - Provides access to device configuration registers and to time-slot data
  - Supports both *Motorola*<sup>‡</sup> nonmultiplexed and *Intel*<sup>§</sup> multiplexed/nonmultiplexed modes
- Substrate switching of nibbles, dibits, or bits
- Programmable GPIO

- Two independently programmable groups of up to 12 framing signals each
- 3.3 V local I/O with 5 V tolerant inputs and TTL-compatible outputs
- Boundary-scan testing support
- 208-pin, plastic SQFP
- 217-pin BGA package

### Applications

- Computer-telephony systems
- Enhanced service platforms
- WAN access devices
- PBXs

### Description

The *Ambassador* T8105 is an H.100/H.110-compliant device that provides a complete interface between the H.100/H.110 bus and a wide variety of telephony interface components, processors, and other circuits. The bus interface provides all signals needed for the H.100/H.110 bus, the H-*MVIP* and *MVIP-90* buses, or the SC-bus. Local interfaces include sixteen serial inputs and sixteen serial outputs based on the Lucent concentration highway interface (CHI). Two built-in time-slot interchangers are included. The first provides a local switching domain with up to 1024 programmable connections between time slots on the local CHI inputs and outputs. The second supports up to 512 programmable connections between any time slot on the H.100/H.110 bus and any time slot in the local switching domain. The *Ambassador* T8105 is configured via a microprocessor interface. This interface can also read and write time-slot and device data.

\* *MVIP* is a trademark of Natural MicroSystems Corporation.

† *Dialogic* is a registered trademark of Dialogic Corporation.

‡ *Motorola* is a registered trademark of Motorola, Inc.

§ *Intel* is a registered trademark of Intel Corporation.

**Description** (continued)

Onboard clock circuitry, including a digital phase-locked loop, supports all H.100/H.110 clock modes including *MVIP* and SC-bus compatibility clocks. The local CHI interfaces support PCM rates of 2.048 Mbits/s, 4.096 Mbits/s, and 8.192 Mbits/s. The *Ambassador T8105* has internal circuitry to support either minimum latency or multi-time-slot frame integrity. Frame integrity is a requisite feature for applications that switch wideband data (ISDN H-channels). Minimum latency is advantageous in voice applications.

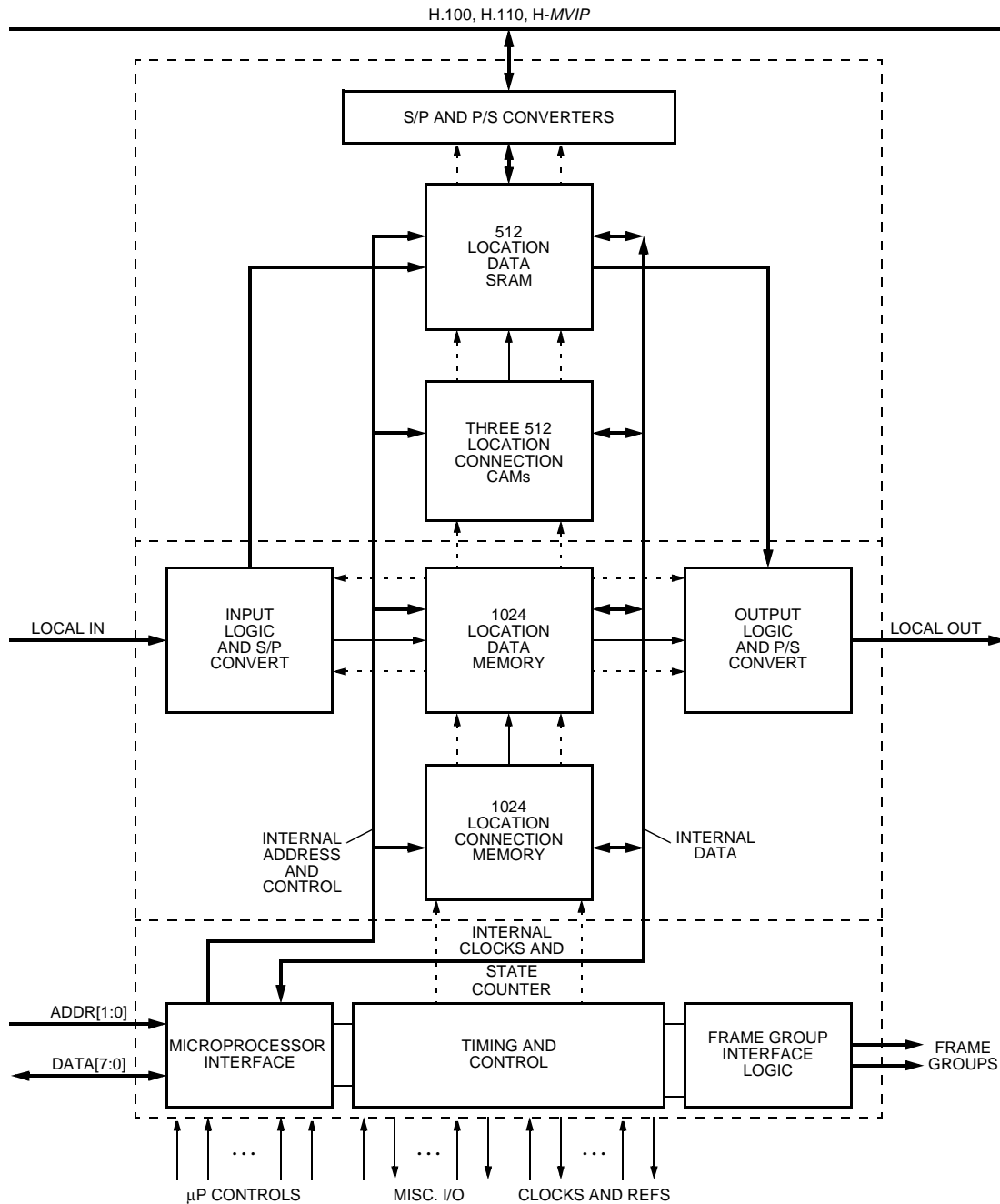

5-6101(F)c

**Figure 1. Block Diagram of the Ambassador**

## Application Overview

The integration of computers and telecommunications has enabled a wide range of new communications applications and has fueled an enormous growth in communications markets. A key element in the development of computer-based communications equipment has been the addition of an auxiliary telecom bus to existing computer systems. Most manufacturers of high-capacity, computer-based telecommunications equipment have incorporated some such telecom bus in their systems. Typically, these buses and bus interfaces are designed to transport and switch  $N \times 64$  kbits/s low-latency telecom traffic between boards within the computer, independent of the computer's I/O and memory buses. At least a half dozen of these PC-based telecom buses emerged in the early 1990s for use within equipment based on ISA/EISA and MCA computers.

With the advent of the H.100/H.110 bus specification by the Enterprise Computer Telephony Forum, the computer-telephony industry has agreed on a single tele-

com bus for use with PCI and compact PCI computers. H.100/H.110 facilitates interoperation of components, thus providing maximum flexibility to equipment manufacturers, value-added resellers, system integrators, and others building computer-based telecommunications applications.

Subrate switching is the ability to switch part(s) of one byte from one stream/time slot to another stream/time slot. The parts are the following:

- Nibbles (4 bits)—representing a 32 kbits/s subrate
- Dibits (2 bits)—representing a 16 kbits/s subrate
- Bits—representing an 8 kbits/s subrate

H.100/H.110 data transfers are always bytes. If subrate switching is used, the T8100A constructs a byte consisting of the subrate samples. The constructed byte may contain any combination of nibbles, dibits, or bits. In addition, individual data bits can be placed within a byte along with don't care bits.

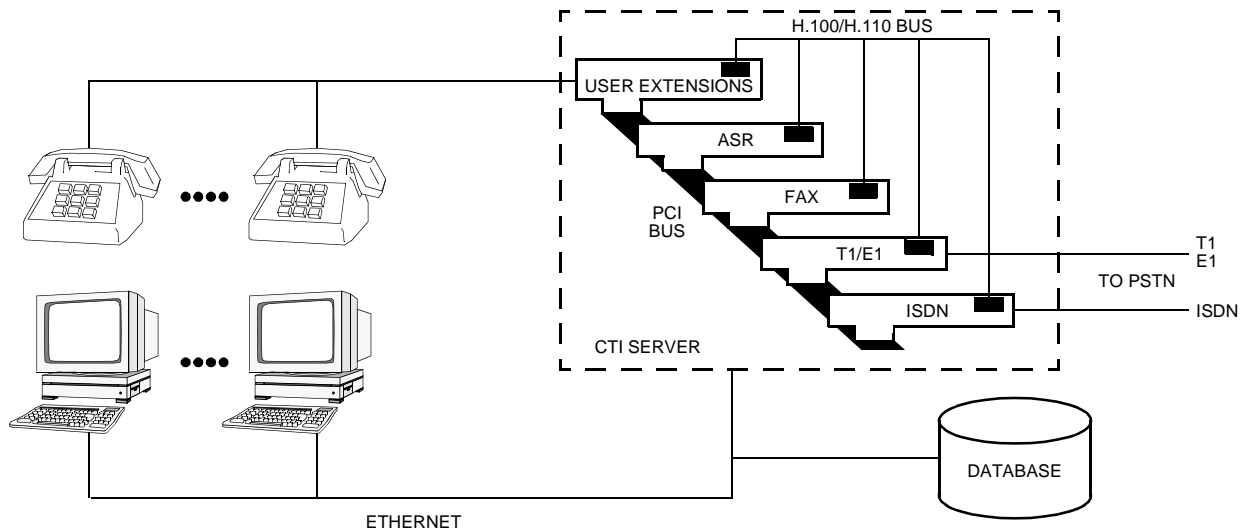

Figure 2. CTI Call Center Application

5-6099F

## T8105 Selection Guide

| Features                   | T8100 | T8100A | T8102 | T8105 |
|----------------------------|-------|--------|-------|-------|
| Subrate switching          | —     | √      | √     | √     |
| Local-to-local connections | 1,024 | 1,024  | —     | 1,024 |
| Local-to-H.100 connections | 256   | 256    | 512   | 512   |
| CT_NETREFs                 | 1     | 2      | 2     | 2     |

For additional information, contact your Microelectronics Group Account Manager or the following:

INTERNET: <http://www.lucent.com/micro>

E-MAIL: [docmaster@micro.lucent.com](mailto:docmaster@micro.lucent.com)

N. AMERICA: Microelectronics Group, Lucent Technologies Inc., 555 Union Boulevard, Room 30L-15P-BA, Allentown, PA 18103  
1-800-372-2447, FAX 610-712-4106 (In CANADA: 1-800-553-2448, FAX 610-712-4106)

ASIA PACIFIC: Microelectronics Group, Lucent Technologies Singapore Pte. Ltd., 77 Science Park Drive, #03-18 Cintech III, Singapore 118256  
Tel. (65) 778 8833, FAX (65) 777 7495

CHINA: Microelectronics Group, Lucent Technologies (China) Co., Ltd., A-F2, 23/F, Zao Fong Universe Building, 1800 Zhong Shan Xi Road, Shanghai 200233 P. R. China Tel. (86) 21 6440 0468, ext. 316, FAX (86) 21 6440 0652

JAPAN: Microelectronics Group, Lucent Technologies Japan Ltd., 7-18, Higashi-Gotanda 2-chome, Shinagawa-ku, Tokyo 141, Japan  
Tel. (81) 3 5421 1600, FAX (81) 3 5421 1700

EUROPE: Data Requests: MICROELECTRONICS GROUP DATALINE: Tel. (44) 1189 324 299, FAX (44) 1189 328 148

Technical Inquiries: GERMANY: (49) 89 95086 0 (Munich), UNITED KINGDOM: (44) 1344 865 900 (Bracknell),

FRANCE: (33) 1 48 83 68 00 (Paris), SWEDEN: (46) 8 600 7070 (Stockholm), FINLAND: (358) 9 4354 2800 (Helsinki),

ITALY: (39) 2 6608131 (Milan), SPAIN: (34) 1 807 1441 (Madrid)

Lucent Technologies Inc. reserves the right to make changes to the product(s) or information contained herein without notice. No liability is assumed as a result of their use or application. No rights under any patent accompany the sale of any such product(s) or information. *Ambassador* is a trademark of Lucent Technologies Inc.

