

DUAL AUDIO POWER AMPLIFIER

The KIA6240K is dual power amplifier for consumer application. This IC provides an output power of 6 watts per channel (at $V_{CC}=22V$, $f=1kHz$, $R_L=8\Omega$, $THD=0.5\%$) It is suitable for power amplifier of TV and home stereo.

FEATURES

- High output power : $P_{OUT}=6W$ (Typ.)
($V_{CC}=22V$, $R_L=8\Omega$, $f=1kHz$, $THD=0.5\%$)
- High current capability.
- AC short circuit protection.
- Thermal overload protection.
- Operation supply voltage range : $V_{CC(opr)}=8\sim 26V$.

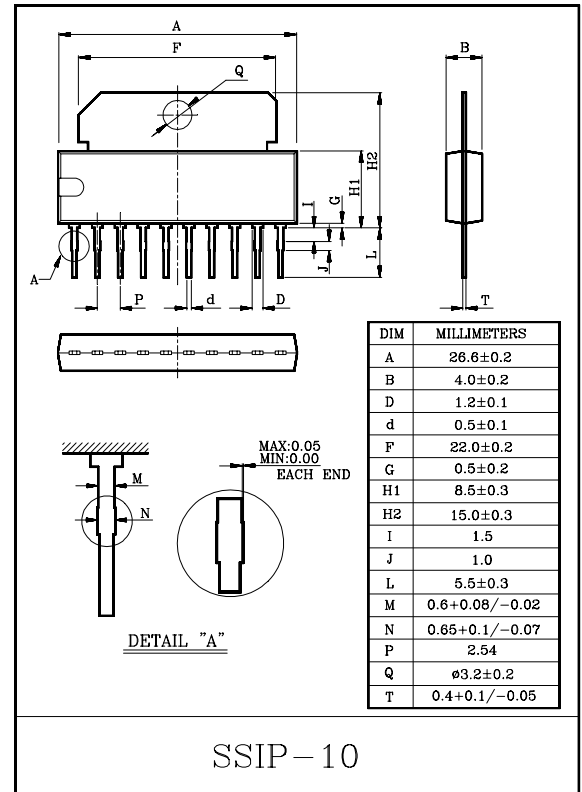

MAXIMUM RATINGS ($T_a=25^\circ C$)

CHARACTERISTIC	SYMBOL	RATING	UNIT
Supply Voltage	V_{CC}	28	V
Output Current (repetitive $f \geq 20Hz$)	$I_{O(peak)}$	3	A
Output Current (non repetitive $t=100\mu S$)	$I_{O(peak)}$	3.5	A
Power Dissipation ($T_{case}=70^\circ C$)	P_D	10	W
Operating Temperature	T_{opr}	-20~75	$^\circ C$
Storage Temperature	T_{stg}	-55~150	$^\circ C$

KIA6240K

BLOCK DIAGRAM / APPLICATION CIRCUIT

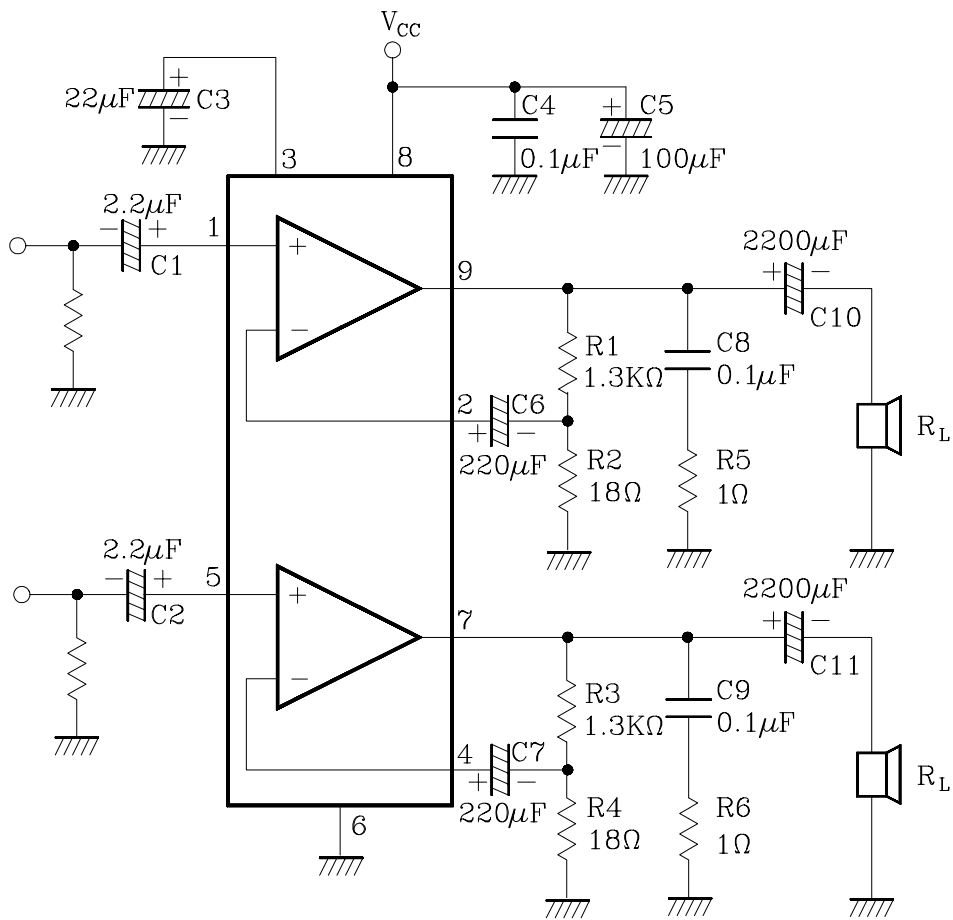

PIN CONFIGURATION (TOP VIEW)

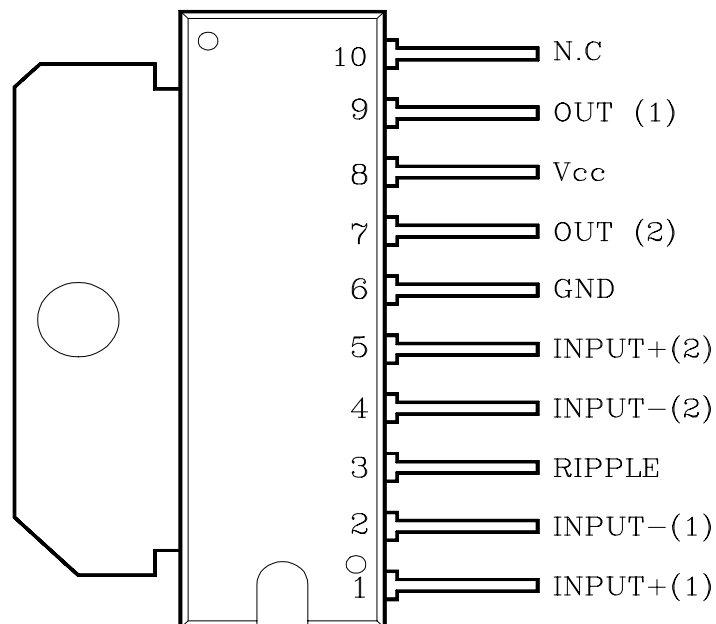

KIA6240K

ELECTRICAL CHARACTERISTICS

(Unless otherwise specified, $V_{CC}=18V$, $f=1kHz$, $R_g=600\Omega$, $R_L=8\Omega$, $T_a=25^\circ C$)

CHARACTERISTIC	SYMBOL	TEST CIRCUIT	TEST CONDITION	MIN.	TYP.	MAX.	UNIT	
Quiescent Current	I_{CCQ}	-	$V_{IN}=0$	-	50	90	mA	
Quiescent Output Voltage	V_O	-		-	8.5	-	V	
Output Power	P_{OUT} (1)	-	$f=100Hz\sim 6kHz$, $V_{CC}=18V$, $R_L=4\Omega$, $THD=0.5\%$	5.0	6	-	W	
	P_{OUT} (2)	-	$f=100Hz\sim 6kHz$, $V_{CC}=22V$, $R_L=8\Omega$, $THD=0.5\%$	5.0	6	-		
Total Harmonic Distortion	THD(1)	-	$V_{CC}=18V$, $R_L=4\Omega$ $P_{OUT}=100mW$ to $3W$	-	0.1	-	%	
	THD(2)	-	$V_{CC}=22V$, $R_L=8\Omega$ $P_{OUT}=100mW$ to $3W$	-	0.05	-		
Cross Talk	C.T	-	$R_g=10k\Omega$, $V_{OUT}=0.775V_{rms}$	$f=1kHz$	50	60	-	dB
				$f=10kHz$	40	50	-	
Input Saturation Voltage	V_{IN}	-		300	-	-	mV_{rms}	
Input Resistance	R_{IN}	-		70	200	-	$k\Omega$	
Voltage Gain	G_V	-	$V_{OUT}=0.775V_{rms}$	35.5	36	36.5	dB	
Input Noise voltage	V_{NI}	-	$R_g=10k\Omega$, $BW=20Hz\sim 20kHz$	-	2.5	8.0	μV_{rms}	
Ripple Rejection Ratio	R.R	-	$R_g=10k\Omega$, $V_{ripple}=0.5V$, $f=100Hz$	-	-55	-	dB	
Thermal Shut-down Junction Temperature	T_j	-		-	145	-	$^\circ C$	

KIA6240K

EXTERNAL PARTS TABLE

The recommended values of the components are those shown on application circuit.
Different values can be used; the following table can help the designer.

Parts Number	Typical	Purpose	Influence		Note
			Smaller Than Typ.	Larger Than Typ.	
R ₁ , R ₃	1.3kΩ	Close Loop Gain Setting *	Decrease of Gain	Increase of Gain	
R ₂ , R ₄	18Ω		Increase of Gain	Decrease of Gain	
R ₅ , R ₆	1Ω	Frquency Stability		Danger of Oscillation at High Frequency with inductive load	
C ₁ , C ₂	2.2μF	Input D.C Decoupling	High Turn-on Pop Higher Low Frquency Cutooff Increase of Noise	High Turn-on Delay	
C ₃	22μF	Ripple Rejection	Degradation of Ripple Rejection	Better Ripple Rejection Ratio increase of the Switch-on time	
C ₆ , C ₇	220μF	Feedback Input D.C Decoupling			
C ₈ , C ₉	0.1μF	Frequency Stability	Danger of Oscillation		

* : The closed loop gain must be higher than 26dB.

KIA6240K

SCHEMATIC DIAGRAM

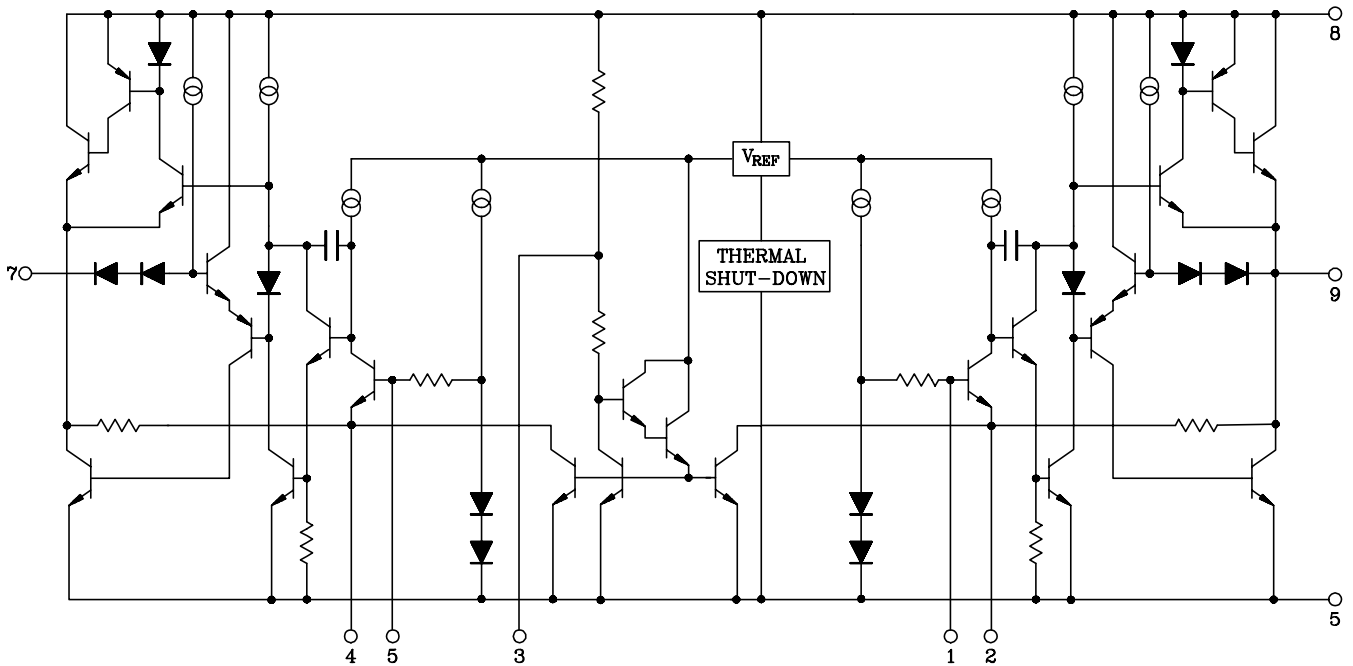

APPLICATION INFORMATION

12W Bridge Amplifier (THD=0.5%, $G_V=40\text{dB}$)

