

PLEASE CHECK WWW.MOLEX.COM FOR LATEST PART INFORMATION

Part Number: [0678008085](#)
Status: **Active**
Overview: [serial_ata_products](#)
Description: 1.27mm (.050") Pitch Serial ATA High Speed Header, Vertical, Through Hole, with Locking Latch, 7 Circuits, 0.38µm (15µ") Gold (Au) Selective Plating, for 2.40mm (.094") PCB, Blue, Footprint A, with PCB Locator Tabs, Lead-free

Documents:

[3D Model](#) [RoHS Certificate of Compliance \(PDF\)](#)
[Drawing \(PDF\)](#)

Agency Certification

CSA LR 19980
 UL E29179

General

Product Family PCB Headers
 Series [67800](#)
 Application Board-to-Board, Wire-to-Board
 Comments In-line Solder Pin|Footprint A
 Overview [serial_ata_products](#)
 Product Name Serial ATA

Physical

Breakaway No
 Circuits (Loaded) 7
 Circuits (maximum) 7
 Color - Resin Blue
 Durability (mating cycles max) 50
 First Mate / Last Break Yes
 Flammability 94V-0
 Glow-Wire Compliant No
 Guide to Mating Part No
 Keying to Mating Part Yes
 Lock to Mating Part Yes
 Material - Metal Brass
 Material - Plating Mating Gold
 Material - Plating Termination Tin
 Number of Rows 1
 Orientation Vertical
 PC Tail Length (in) 0.128 In
 PC Tail Length (mm) 3.25 mm
 PCB Locator Yes
 PCB Retention Yes
 PCB Thickness Recommended (in) 0.093 In
 PCB Thickness Recommended (mm) 2.40 mm
 Packaging Type Tray
 Pitch - Mating Interface (in) 0.050 In
 Pitch - Mating Interface (mm) 1.27 mm
 Pitch - Term. Interface (in) 0.050 In
 Pitch - Term. Interface (mm) 1.27 mm
 Polarized to Mating Part Yes
 Shrouded Fully
 Stackable No
 Surface Mount Compatible (SMC) No
 Temperature Range - Operating -55°C to +85°C

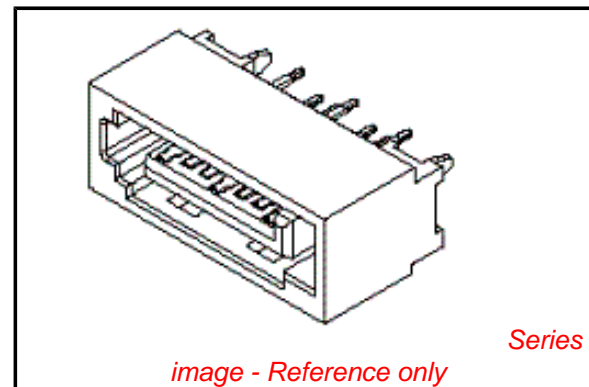

image - Reference only

EU RoHS

ELV and RoHS Compliant
REACH SVHC
 Not Reviewed
Halogen-Free Status
Not Reviewed

China RoHS



Need more information on product environmental compliance?

Email productcompliance@molex.com
 For a multiple part number RoHS Certificate of Compliance, [click here](#)

Please visit the [Contact Us](#) section for any non-product compliance questions.

Search Parts in this Series
[67800Series](#)

Termination Interface: Style

Through Hole

Electrical

Current - Maximum per Contact

1.5A

Voltage - Maximum

15V

Solder Process Data

Lead-free Process Capability

Wave Capable (TH only)

Material Info

Reference - Drawing Numbers

Packaging Specification

PK-67800-001

Sales Drawing

SD-67800-008

This document was generated on 05/26/2010

PLEASE CHECK WWW.MOLEX.COM FOR LATEST PART INFORMATION

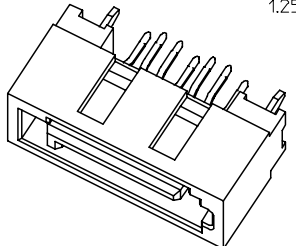
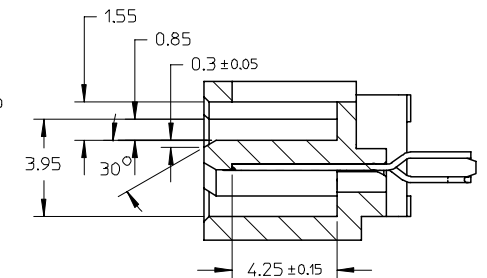
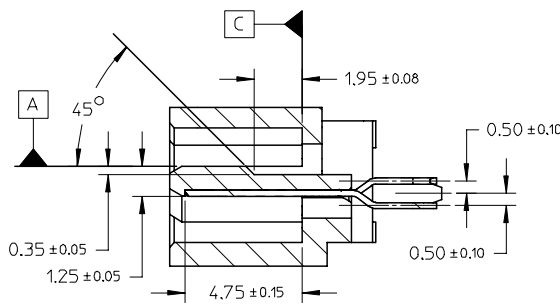
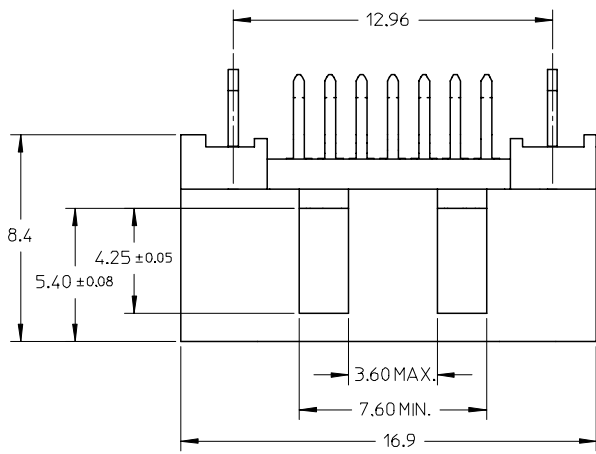

SECTION A-A

SECTION C-C

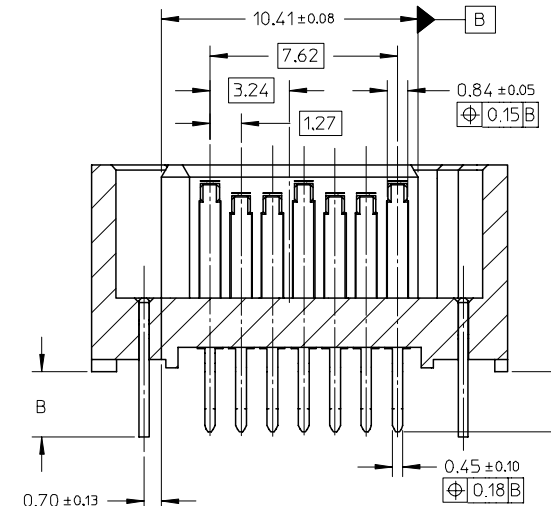
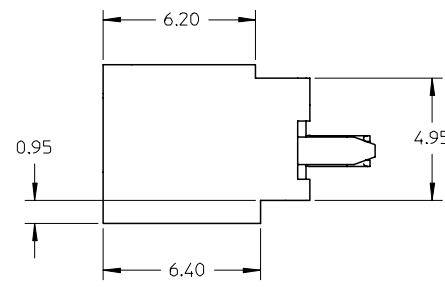

SECTION B-B

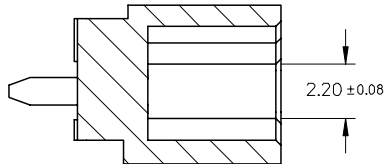
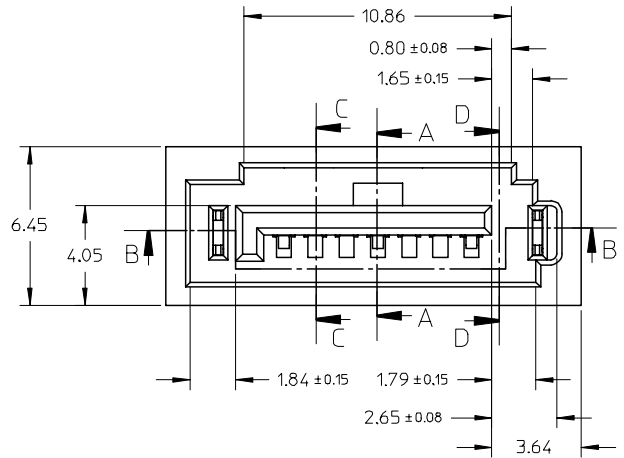

SECTION D-D

ADD PART NUMBER EC NO: SH2007-0324 DRWN: BCHENZ6 CHKD: JTIAN APPR: JNCHEN	2006/11/06 2006/11/06 2006/11/15	DESCRIPTION
---	--	-------------

QUALITY SYMBOLS	▽=0	∇=0
-----------------	-----	-----

GENERAL TOLERANCES (UNLESS SPECIFIED)	mm	INCH
4 PLACES	± ---	± ---
3 PLACES	± ---	± ---
2 PLACES	± 0.15	± ---
1 PLACE	± 0.25	± ---
ANGULAR ± 1 °		
DRAFT WHERE APPLICABLE MUST REMAIN WITHIN DIMENSIONS		

DIMENSION STYLE MM ONLY	
DRAWN BY GRATE	DATE 2004/02/02
CHECKED BY YA JUN	DATE 2004/02/02
APPROVED BY SAM	DATE 2004/02/02
MATERIAL NO.	
SEE SHEET 2	

SCALE 5:1	DESIGN UNITS METRIC	THIRD ANGLE PROJECTION
TITLE HIGH SPEED CONNECTOR 1.27MM PITCH VERTICAL DIP SOLDER TAIL		
MOLEX INCORPORATED		
DOCUMENT NO. SD-67800-008	SHEET NO. 1 OF 2	
THIS DRAWING CONTAINS INFORMATION THAT IS PROPRIETARY TO MOLEX INCORPORATED AND SHOULD NOT BE USED WITHOUT WRITTEN PERMISSION		

10 9 8 7 6 5 4 3 2 1

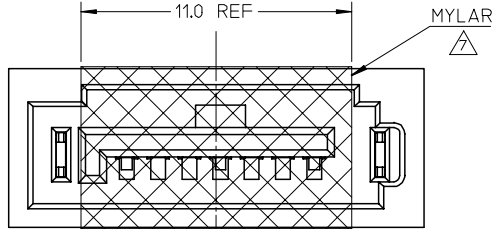
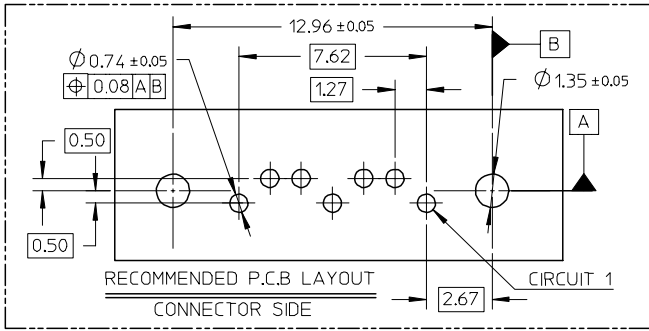

SCHEMATIC DRAWING OF MYLAR ONLY FOR 678008205 (SCALE 5:1)

- NOTES:
- MATERIAL:
HOUSING/COLOR: SEE CHART, GLASS FILLED, UL94V-0,
TERMINAL/PEG: BRASS
 - TERMINAL PLATING:
CONTACT AREA: (a) GOLD FLASH
(b) GOLD, THICKNESS=0.76 MICRON MINIMUM
(c) GOLD, THICKNESS=0.38 MICRON MINIMUM
SOLDER TAIL: TIN PLATED 1.27 MICRON MINIMUM OVER
NICKEL PLATED 1.27 MICRON MINIMUM
 - POST PLATING: TIN PLATED 1.27 MICRON MINIMUM OVER
NICKEL PLATED 1.8 MICRON MINIMUM
 - PACKAGING:
FOR 678008205: TAPE & REEL, REFER TO PK-67800-003
FOR OTHER P/N: TRAY, REFER TO PK-67800-001
 - PRODUCT SPECIFICATION REFER TO PS-67491-001
 - RECOMMENDED SOLDERING PROCESS:
THERMAL PLASTIC FOR WAVE SOLDEING PROCESS
HIGH TEMPERATURE THERMAL PLASTIC FOR IR SOLDERING PROCESS
- △7. THE MYLAR STICKED ON THE HOUSING IS JUST USED FOR PICK-UP PLACE, PLEASE REMOVE IT AFTER REFLOW

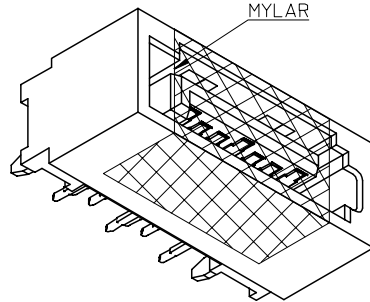

678008065	SEE NOTE2(c)								
678008062	SEE NOTE2(b)	3.25	3.45	2.40+/-0.05					
678008061	SEE NOTE2(a)								
678008055	SEE NOTE2(c)								
678008052	SEE NOTE2(b)	2.85	3.05	2.00+/-0.05	THERMAL PLASTIC	NATURE COLOR			
678008051	SEE NOTE2(a)								
678008245	SEE NOTE2(c)	2.10							
678008045	SEE NOTE2(c)								
678008042	SEE NOTE2(b)	2.45	2.65	1.60+/-0.05					
678008041	SEE NOTE2(a)								
678008085	SEE NOTE2(c)								
678008082	SEE NOTE2(b)	3.25	3.45	2.40+/-0.05					
678008081	SEE NOTE2(a)								
678008075	SEE NOTE2(c)								
678008072	SEE NOTE2(b)	2.85	3.05	2.00+/-0.05	THERMAL PLASTIC	PROCESS BLUE C ΔE<3			
678008071	SEE NOTE2(a)								
678008235	SEE NOTE2(c)	2.10							
678008035	SEE NOTE2(c)								
678008032	SEE NOTE2(b)	2.45	2.65	1.60+/-0.05					
678008031	SEE NOTE2(a)								
678008025	SEE NOTE2(c)								
678008022	SEE NOTE2(b)	3.25	3.45	2.40+/-0.05					
678008021	SEE NOTE2(a)								
678008015	SEE NOTE2(c)								
678008012	SEE NOTE2(b)	2.85	3.05	2.00+/-0.05	THERMAL PLASTIC	BLACK			
678008011	SEE NOTE2(a)								
678008305	SEE NOTE2(c)	2.10							
678008005	SEE NOTE2(c)								
678008002	SEE NOTE2(b)	2.45	2.65	1.60+/-0.05					
678008001	SEE NOTE2(a)								
MATERIAL NUMBER	PLATING TYPE	DIM A	DIM B	P.C.B THICKNESS	PLASTIC TYPE	PLASTIC COLOR	REMARK		

△ F

678008125	SEE NOTE2(c)								
678008122	SEE NOTE2(b)	3.25	3.45	2.40+/-0.05					
678008121	SEE NOTE2(a)								
678008115	SEE NOTE2(c)								
678008112	SEE NOTE2(b)	2.85	3.05	2.00+/-0.05	THERMAL PLASTIC	BLACK	PURE TIN		
678008111	SEE NOTE2(a)								
678008205	SEE NOTE2(c)								
678008105	SEE NOTE2(c)	2.45	2.65	1.60+/-0.05					
678008102	SEE NOTE2(b)								
678008101	SEE NOTE2(a)								
MATERIAL NUMBER	PLATING TYPE	DIM A	DIM B	P.C.B THICKNESS	PLASTIC TYPE	PLASTIC COLOR	REMARK		

ADD PART NUMBER EC NO: SH2007-0324 DRWN: BCHENZ6 CHKD: JTIAN APPR: JNCHEN	QUALITY SYMBOLS ▽=0 ▽C=0	GENERAL TOLERANCES (UNLESS SPECIFIED)		DIMENSION STYLE MM ONLY		SCALE 1:1	DESIGN UNITS METRIC	THIRD ANGLE PROJECTION		
				DRAWN BY GRATE		DATE 2004/02/02	TITLE HIGH SPEED CONNECTOR 1.27MM PITCH VERTICAL DIP SOLDER TAIL			
				CHECKED BY YA JUN		DATE 2004/02/02	APPROVED BY SAM			
				APPROVED BY SAM		DATE 2004/02/02	MATERIAL NO. SEE CHART			
		DRAFT WHERE APPLICABLE MUST REMAIN WITHIN DIMENSIONS		MATERIAL NO. SEE CHART		DOCUMENT NO. SD-67800-008		SHEET NO. 2 OF 2		

9 8 7 6 5 4 3 2 1