

# CMOS 5 x 7 Alphanumeric Displays

## Technical Data

### HCMS-200X Series HCMS-230X Series

#### Features

- **On-Board Low Power CMOS IC:**  
Integrated Shift Register with Constant Current LED Drivers
- **Wide Operating Temperature Range:**  
-40°C to +85°C
- **Compact Glass Ceramic 4 Character Package:**  
HCMS-200X Series End Stackable  
HCMS-230X Series X-Y Stackable
- **Five Colors:**  
Standard Red  
High Efficiency Red  
Orange  
Yellow  
High Performance Green
- **5 X 7 LED Matrix Displays Full ASCII Set**
- **Two Character Heights:**  
3.8mm (0.15 inch)  
5.0mm (0.20 inch)
- **Wide Viewing Angle:**  
X Axis =  $\pm 50^\circ$   
Y Axis =  $\pm 65^\circ$
- **Long Viewing Distance:**  
HCMS-200X Series to 2.6 Meters (8.6 Feet)  
HCMS-230X Series to 3.5 Meters (11.5 Feet)
- **Categorized for Luminous Intensity**

- **HCMS-2001/-2003, HCMS-2301/-2303:**  
Categorized for Color

#### Typical Applications

- Commercial Avionics
- Instrumentation
- Medical Instruments
- Business Machines

#### Description

The HCMS-200X and HCMS-230X series are 5x7 LED four character displays contained in 12 pin dual-in-line packages designed for displaying alphanumeric information. The character height for the HCMS-200X series displays is 3.8mm (0.15 inch), and for the

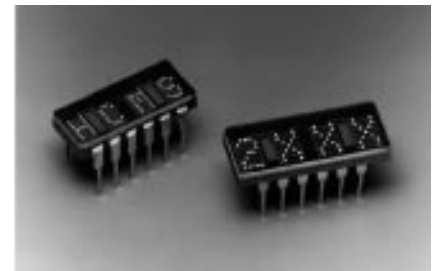

HCMS-230X series displays the character height is 5.0mm (0.20 inch). These displays are available in five LED colors: standard red, high efficiency red, orange, yellow and high performance green. The HCMS-200X series displays are end stackable and the HCMS-230X series displays are end/row stackable.

#### Display Selection Table

Part Number	Character Size	LED Color
HCMS-2000	3.8 mm (0.15 inch)	Standard Red
HCMS-2001	3.8 mm (0.15 inch)	Yellow
HCMS-2002	3.8 mm (0.15 inch)	High-Efficiency Red
HCMS-2003	3.8 mm (0.15 inch)	High-Performance Green
HCMS-2004	3.8 mm (0.15 inch)	Orange
HCMS-2300	5.0 mm (0.20 inch)	Standard Red
HCMS-2301	5.0 mm (0.20 inch)	Yellow
HCMS-2302	5.0 mm (0.20 inch)	High-Efficiency Red
HCMS-2303	5.0 mm (0.20 inch)	High-Performance Green
HCMS-2304	5.0 mm (0.20 inch)	Orange

ESD WARNING: STANDARD CMOS HANDLING PRECAUTIONS SHOULD BE OBSERVED.

These displays are designed with on-board CMOS integrated circuits for use in applications where conservation of power is important. The two CMOS ICs form an on-board serial-in-parallel-out 28-bit shift register with constant current output LED row drivers. Decoded column data is clocked into the on-board shift register for

each refresh cycle. Full character display is achieved with external column strobing.

**Compatibility with HDSP-200X/230X TTL IC Series Displays**

The HCMS-200X, HCMS-230X CMOS IC displays are “drop-in” replacements for the equivalent

HDSP-200X, HDSP-230X TTL IC displays. The 12 pin glass/ceramic package configuration, four digit character matrix and pin functions are identical.

**Package Dimensions**

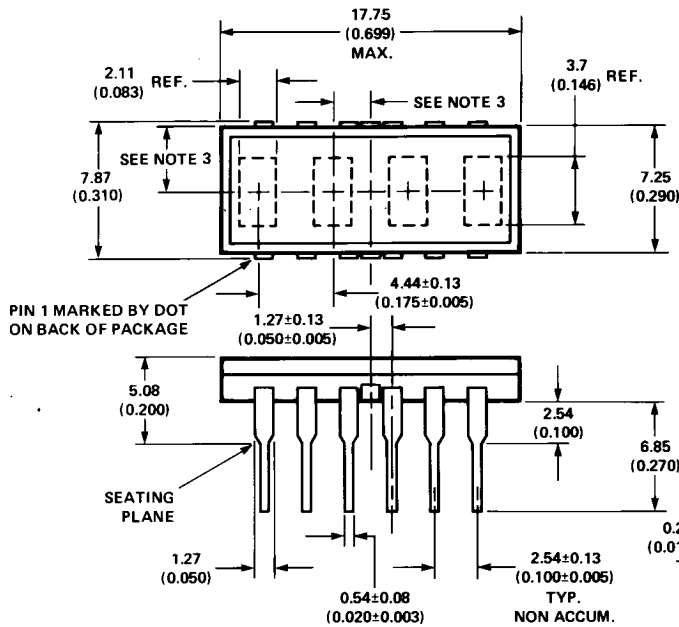

PIN	FUNCTION	PIN	FUNCTION
1	COLUMN 1	7	DATA OUT
2	COLUMN 2	8	V <sub>B</sub>
3	COLUMN 3	9	V <sub>DD</sub>
4	COLUMN 4	10	CLOCK
5	COLUMN 5	11	GROUND
6	INT. CONNECT*	12	DATA IN

\* DO NOT CONNECT OR USE

**HCMS-200X Series**

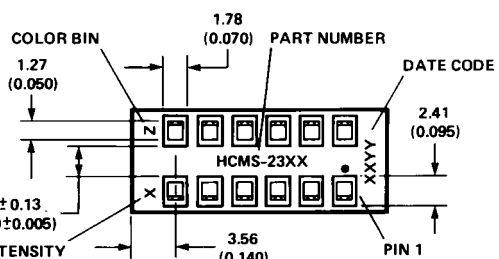
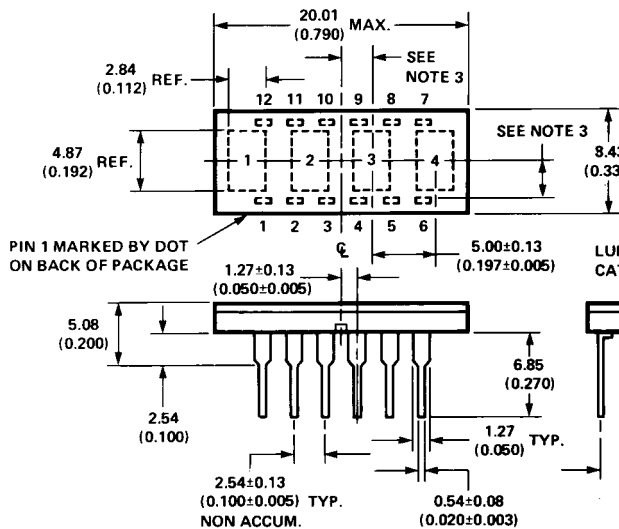

PIN	FUNCTION	PIN	FUNCTION
1	COLUMN 1	7	DATA OUT
2	COLUMN 2	8	V <sub>B</sub>
3	COLUMN 3	9	V <sub>DD</sub>
4	COLUMN 4	10	CLOCK
5	COLUMN 5	11	GROUND
6	INT. CONNECT*	12	DATA IN

\* DO NOT CONNECT OR USE

- NOTES:
1. DIMENSIONS IN MILLIMETRES (INCHES)
  2. UNLESS OTHERWISE SPECIFIED THE TOLERANCE ON ALL DIMENSIONS IS ±0.38mm (±0.015).
  3. CHARACTERS ARE CENTERED WITH RESPECT TO LEADS WITHIN ±0.13mm (±0.005").
  4. LEAD MATERIAL IS COPPER ALLOY, SOLDER DIPPED.

**HCMS-230X Series**

## Absolute Maximum Ratings

Supply Voltage $V_{DD}$ to Ground .....	-0.3 V to 7.0 V
Data Input, Data Output, $V_B$ .....	-0.3 V to $V_{DD}$
Column Input Voltage, $V_{COL}$ .....	-0.3 V to $V_{DD}$
Free Air Operating Temperature Range, $T_A$ .....	-40°C to +85°C
Storage Temperature Range, $T_S$ .....	-55°C to +100°C
Maximum Allowable Package Power Dissipation, $P_D$ <sup>[1,2]</sup>	
HCMS-2000/-2001/-2002/-2003/-2004 at $T_A = 78^\circ\text{C}$ .....	0.79 Watts
HCMS-2300 at $T_A = 85^\circ\text{C}$ .....	0.79 Watts
HCMS-2301/-2302/-2303/-2304 at $T_A = 85^\circ\text{C}$ .....	0.92 Watts
Maximum Solder Temperature	
1.59 mm (0.063") Below Seating Plane, $t < 5$ sec .....	260°C
ESD Protection @ 1.5 k $\Omega$ , 100 pF .....	$V_Z = 4$ kV (each pin)

### Notes:

- Maximum allowable power dissipation is derived from  $V_{DD} = 5.25$  V,  $V_B = 2.4$  V,  $V_{COL} = 3.5$  V, 20 LEDs on per character, 20% DF.
- The power dissipation for these displays should be derated as follows:  
 HCMS-200X series derate above 78°C at 18 mW/°C,  $R\theta_{JA} = 60^\circ\text{C/W}$ .  
 HCMS-230X series may be operated without derating up to  $T_A = 85^\circ\text{C}$ ,  
 $R\theta_{JA} = 45^\circ\text{C/W}$ .  
 Deratings based on  $R\theta_{PC,A} = 35^\circ\text{C/W}$  per display for printed circuit board assembly. See Figure 1 for power derating.

## Recommended Operating Conditions over Operating Temperature Range (-40°C to +85°C)

Parameter	Symbol	Min.	Typ.	Max.	Units
Supply Voltage	$V_{DD}$	4.75	5.00	5.25	V
Data Out Current, Low State	$I_{OL}$			1.6	mA
Data Out Current, High State	$I_{OH}$			-0.5	mA
Column Input Voltage	$V_{COL}$	2.75	3.0	3.5	V
Setup Time	$t_{SETUP}$	10			ns
Hold Time	$t_{HOLD}$	25			ns
Clock Pulse Width High	$t_{WH(CLOCK)}$	50			ns
Clock Pulse Width Low	$t_{WL(CLOCK)}$	50			ns
Clock High to Low Transition	$t_{THL}$			200	ns
Clock Frequency	$f_{CLOCK}$			5	MHz

### Electrical Characteristics over Operating Temperature Range (-40°C to +85°C)

Parameter	Symbol	Test Conditions	Min.	Typ.*	Max.	Units
Supply Current, Dynamic <sup>[1]</sup>	$I_{DD}$	$f_{CLOCK} = 5 \text{ MHz}$		6.2	7.8	mA
Supply Current, Static <sup>[2]</sup>	$I_{DD\text{Soff}}$ $I_{DD\text{Son}}$	$V_B = 0.4 \text{ V}$ $V_B = 2.4 \text{ V}$		1.8 2.2	2.6 6.0	mA
Column Input Current	$I_{COL}$	$V_B = 0.4 \text{ V}$			10	$\mu\text{A}$
HCMS-2000/-2001/-2002/-2003/-2004		$V_B = 2.4 \text{ V}$		310	384	mA
HCMS-2300		$V_B = 2.4 \text{ V}$		310	384	mA
HCMS-2301/-2302/-2303/-2304		$V_B = 2.4 \text{ V}$		360	451	mA
Input Logic High Data, $V_B$ , Clock	$V_{IH}$	$V_{DD} = 4.75 \text{ V}$	2.0			V
Input Logic Low Data, $V_B$ , Clock	$V_{IL}$	$V_{DD} = 5.25 \text{ V}$			0.8	V
Input Current Data, Clock $V_B$	$I_I$	$V_{DD} = 5.25 \text{ V}$ $0 < V_I < 5.25 \text{ V}$ $0 < V_B < 5.25 \text{ V}$	-10 -40		+1 0	$\mu\text{A}$
Data Out Voltage	$V_{OH}$	$V_{DD} = 4.75 \text{ V}$ $I_{OH} = -0.5 \text{ mA}$ $I_{COL} = 0 \text{ mA}$	2.4	4.2		V
	$V_{OL}$	$V_{DD} = 5.25 \text{ V}$ $I_{OL} = 1.6 \text{ mA}$ $I_{COL} = 0 \text{ mA}$		0.2	0.4	V
Power Dissipation Per Package <sup>[3]</sup>	$P_D$	$V_{DD} = 5.0 \text{ V}$				mW
HCMS-2000/-2001/-2002/-2003/-2004		$V_{COL} = 3.5 \text{ V}$		414		
HCMS-2300		17.5% DF		414		
HCMS-2301/-2302/-2303/-2304		$V_B = 2.4 \text{ V}$ 15 LEDs ON per Character		481		
Thermal Resistance IC Junction-to-Pin <sup>[4]</sup>	$R\theta_{J-PIN}$					
HCMS-2000/-2001/-2002/-2003/-2004				25		
HCMS-2300/-2301/-2302/-2303/-2304				10		$^{\circ}\text{C/W}$

\*All typical values specified at  $V_{DD} = 5.0 \text{ V}$  and  $T_A = 25^{\circ}\text{C}$ .

#### Notes:

- $I_{DD}$  Dynamic is the IC current while clocking column data through the on-board shift register at a clock frequency of 5MHz, the display is not illuminated.
- $I_{DD}$  Static is the IC current after column data is loaded and not being clocked through the on-board shift register.
- Four characters are illuminated with a typical ASCII character composed of 15 dots per character.
- IC junction temperature  $T_J(\text{IC}) = (P_D)(R\theta_{J-PIN} + R\theta_{PC-A}) + T_A$ .

## Optical Characteristics at $T_A = 25^\circ\text{C}$

### Standard Red HCMS-2000/-2300

Description	Symbol	Test Condition	Min.	Typ.*	Max.	Units
Peak Luminous Intensity per LED <sup>[5,9]</sup> HCMS-2000 HCMS-2300 (Character Average)	$I_{\text{VPEAK}}$	$V_{\text{DD}} = 5.0 \text{ V}$ $V_{\text{COL}} = 3.5 \text{ V}$ $V_{\text{B}} = 2.4 \text{ V}$ $T_i = 25^\circ\text{C}^{[7]}$	105 130	200 300		$\mu\text{cd}$
Dominant Wavelength <sup>[8]</sup>	$\lambda_{\text{d}}$			639		nm
Peak Wavelength	$\lambda_{\text{PEAK}}$			655		nm

### Yellow HCMS-2001/-2301

Description	Symbol	Test Condition	Min.	Typ.*	Max.	Units
Peak Luminous Intensity per LED <sup>[5,9]</sup> HCMS-2001 HCMS-2301 (Character Average)	$I_{\text{VPEAK}}$	$V_{\text{DD}} = 5.0 \text{ V}$ $V_{\text{COL}} = 3.5 \text{ V}$ $V_{\text{B}} = 2.4 \text{ V}$ $T_i = 25^\circ\text{C}^{[7]}$	400 650	750 1140		$\mu\text{cd}$
Dominant Wavelength <sup>[6,8]</sup>	$\lambda_{\text{d}}$			585		nm
Peak Wavelength	$\lambda_{\text{PEAK}}$			583		nm

### High Efficiency Red HCMS-2002/-2302

Description	Symbol	Test Condition	Min.	Typ.*	Max.	Unit
Peak Luminous Intensity per LED <sup>[5,9]</sup> HCMS-2002 HCMS-2302 (Character Average)	$I_{\text{VPEAK}}$	$V_{\text{DD}} = 5.0 \text{ V}$ $V_{\text{COL}} = 3.5 \text{ V}$ $V_{\text{B}} = 2.4 \text{ V}$ $T_i = 25^\circ\text{C}^{[7]}$	400 650	1430 1430		$\mu\text{cd}$
Dominant Wavelength <sup>[8]</sup>	$\lambda_{\text{d}}$			625		nm
Peak Wavelength	$\lambda_{\text{PEAK}}$			635		nm

### High Performance Green HCMS-2003/-2303

Description	Symbol	Test Condition	Min.	Typ.*	Max.	Units
Peak Luminous Intensity per LED <sup>[5,9]</sup> HCMS-2003 HCMS-2303 (Character Average)	$I_{\text{VPEAK}}$	$V_{\text{DD}} = 5.0 \text{ V}$ $V_{\text{COL}} = 3.5 \text{ V}$ $V_{\text{B}} = 2.4 \text{ V}$ $T_i = 25^\circ\text{C}^{[7]}$	850 1280	1550 2410		$\mu\text{cd}$
Dominant Wavelength <sup>[6,8]</sup>	$\lambda_{\text{d}}$			574		nm
Peak Wavelength	$\lambda_{\text{PEAK}}$			568		nm

### Orange HCMS-2004/-2304

Description	Symbol	Test Condition	Min.	Typ.*	Max.	Units
Peak Luminous Intensity per HCMS-2004 LED <sup>[5,9]</sup> HCMS-2304 (Character Average)	$I_{VPEAK}$	$V_{DD} = 5.0\text{ V}$ $V_{COL} = 3.5\text{ V}$ $V_B = 2.4\text{ V}$ $T_i = 25^\circ\text{C}^{[7]}$	400 650	1430 1430		$\mu\text{cd}$
Dominant Wavelength <sup>[8]</sup>	$\lambda_d$			602		nm
Peak Wavelength	$\lambda_{PEAK}$			600		nm

\*All typical values specified at  $V_{DD} = 5.0\text{ V}$  and  $T_A = 25^\circ\text{C}$  unless otherwise noted.

#### Notes:

- These LED displays are categorized for luminous intensity, with the intensity category designated by a letter code on the back of the package.
- The HCMS-2001/-2301 and HCMS-2003/-2303 are categorized for color with the color category designated by a number on the back of the package.
- $T_i$  refers to the initial case temperature of the display immediately prior to the light measurement.
- Dominant wavelength,  $\lambda_d$ , is derived from the CIE Chromaticity Diagram, and represents the single wavelength which defines the color of the device.
- The luminous sterance of the individual LED pixels may be calculated using the following equations:

$$L_v (\text{cd/m}^2) = I_v (\text{Candela}) * \text{DF} / \text{A} (\text{Metre})^2$$

$$L_v (\text{Footlamberts}) = \rho I_v (\text{Candela}) * \text{DF} / \text{A} (\text{Foot})^2$$

Where: A = LED pixel area =  $5.3 \times 10^{-8}\text{M}^2$  or  $5.8 \times 10^{-7}\text{ft}^2$   
DF = LED on-time duty factor

### Switching Characteristics, $T_A = -40^\circ\text{C}$ to $+85^\circ\text{C}$

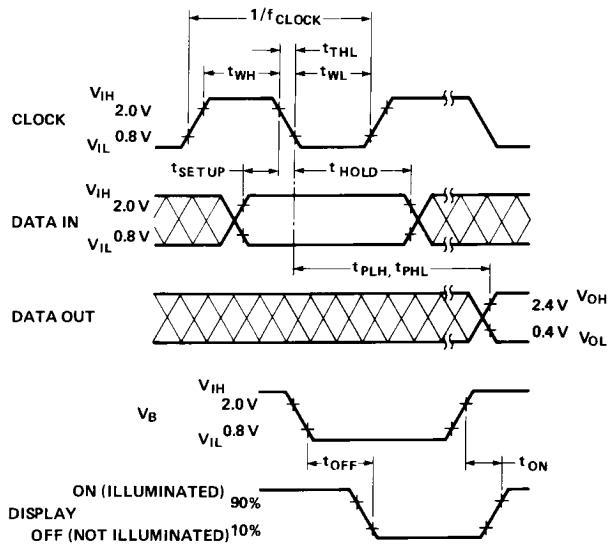

Parameter	Condition	Typ.	Max.	Units
$f_{CLOCK}$ CLOCK Rate			5	MHz
$t_{PLH}$ , $t_{PHL}$ Propagation Delay CLOCK to DATA OUT	$C_L = 15\text{ pF}$ $R_L = 2.4\text{ k}\Omega$		105	ns
$t_{OFF}$ $V_B$ (0.4 V) to Display OFF		4	5	$\mu\text{s}$
$t_{ON}$ $V_B$ (2.4 V) to Display ON		1	2	$\mu\text{s}$

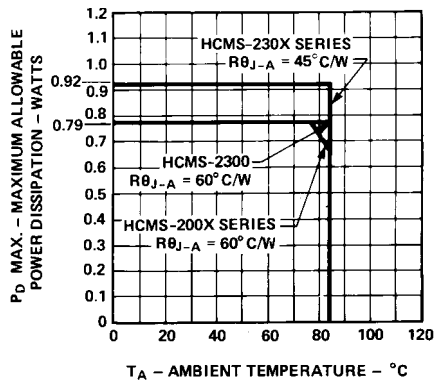

Figure 1. Maximum Allowable Power Dissipation vs Ambient Temperature as a Function of Thermal Resistance Junction-to-Ambient,  $R_{\theta J-A}$ . Derated Operation Assumes  $R_{\theta PC-A} = 35^{\circ}\text{C/W}$  Per Display for the Printed Circuit Board.  $T_j$  (IC) MAX =  $125^{\circ}\text{C}$ .

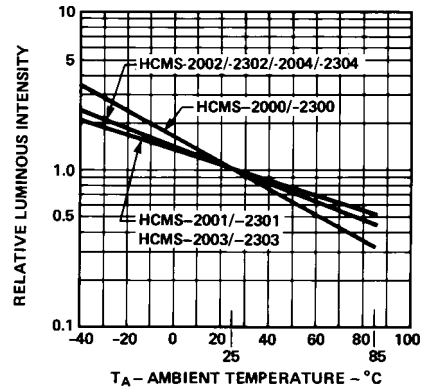

Figure 2. Relative Luminous Intensity vs Display Pin Temperature

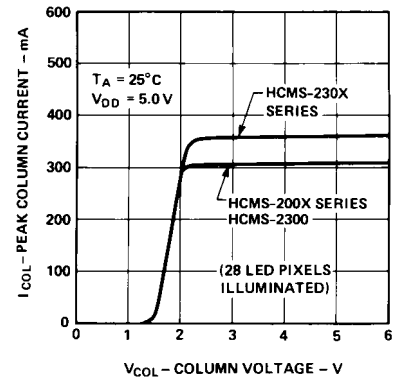

Figure 3. Peak Column Current vs Column Voltage

## Electrical Description

Each display device contains four  $5 \times 7$  LED dot matrix characters and two CMOS integrated circuits, as shown in Figure 4. The two CMOS integrated circuits form an on-board 28 bit serial-in-parallel-out shift register that will accept standard TTL logic levels. The Data Input, pin 12, is connected to bit position 1 and the Data Output, pin 7, is connected to bit position 28. The shift register outputs control constant current sinking LED row drivers. The nominal current sink per LED driver is 11mA for the HCMS-200X displays, 13 mA for the HCMS-230X. A logic 1 stored in the shift register enables the corresponding LED row driver and a logic 0 stored in the shift register disables the corresponding LED row driver.

The electrical configuration of these CMOS IC alphanumeric displays allows for an effective interface to a display controller

circuit that supplies decoded character information. The row data for a given column (one 7 bit byte per character) is loaded (bit serial) into the on-board 28 bit shift register with high to low transitions of the Clock input. To load decoded character information into the display, column data for character 4 is loaded first and the column data for character 1 is loaded last in the following manner. The 7 data bits for column 1, character 4, are loaded into the on-board shift register. Next, the 7 data bits for column 1, character 3, are loaded into the shift register, shifting the character 4 data over one character position. This process is repeated for the other two characters until all 28 bits of column data (four 7 bit bytes of character column data) are loaded into the on-board shift register. Then the column 1 input,  $V_{COL}$  pin 1, is energized to illuminate column 1 in all four characters. This process is repeated for columns 2, 3, 4 and

5. All  $V_{COL}$  inputs should be at logic low to insure the display is off when loading data. The display will be blanked when the blanking input  $V_B$ , pin 8, is at logic low regardless of the outputs of the shift register or whether one of the  $V_{COL}$  inputs is energized.

Refer to Application Note 1016 for drive circuit information.

## ESD Susceptibility

The HCMS-200X/-230X series displays have an ESD susceptibility ratings of CLASS 3 per DOD-STD-1686 and CLASS B per MIL-STD-883C. It is recommended that normal CMOS handling precautions be observed with these devices.

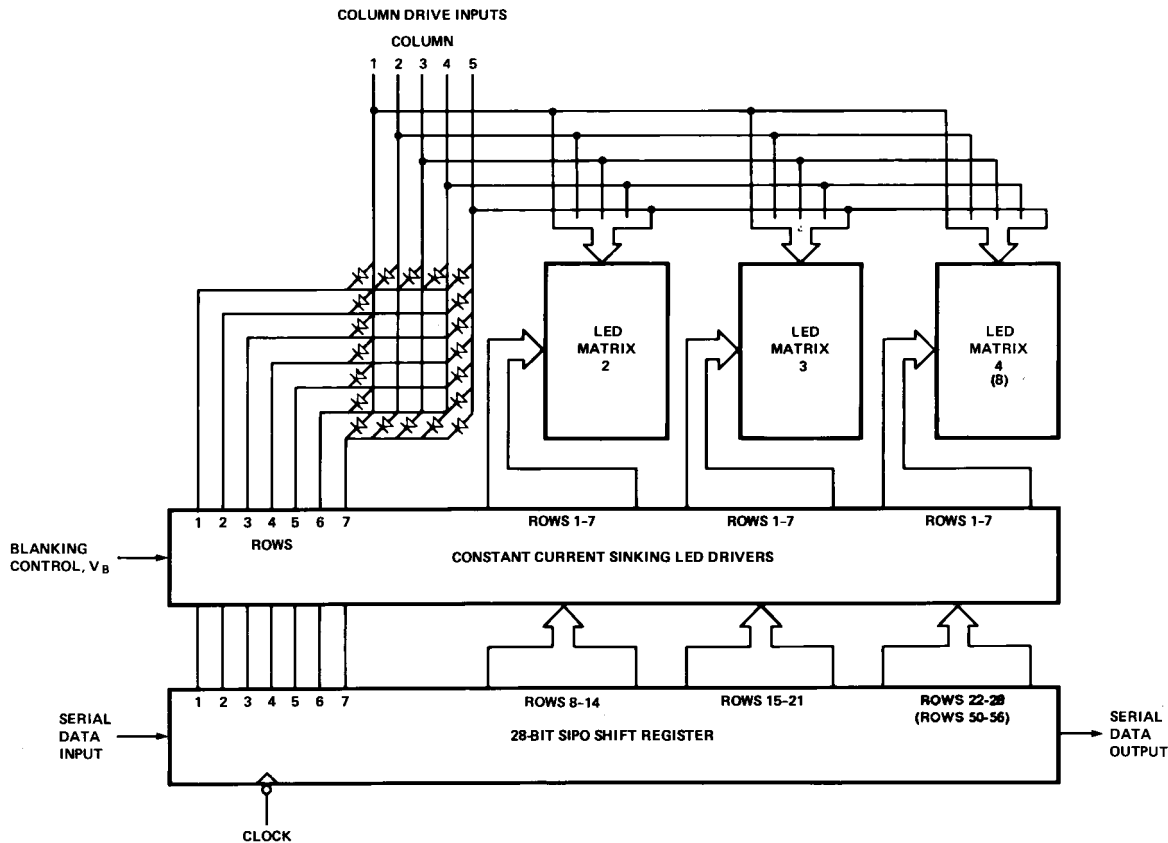
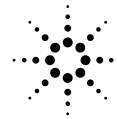

Figure 4. Block Diagram of an HCMS-2XXX Series LED Alphanumeric Display.

### Soldering and Post Solder Cleaning

These displays may be soldered with a standard wave solder process using either an RMA flux and solvent cleaning or an OA flux and aqueous cleaning. For optimum soldering, the solder wave temperature should be 245°C and the dwell time for any display lead passing through the wave should be 1 1/2 to 2 seconds. For more detailed information, refer to Application Note 1027 *Soldering LED Components*.

### Contrast Enhancement

When used with the proper contrast enhancement filters, the HCMS-200X/-230X series displays are readable bright ambients. Refer to Application Note 1029 *Luminous Contrast and Sunlight Readability of the HDSP-235X Series Alphanumeric Displays for Military Applications* for contrast enhancement in bright ambients. Refer to Application Note 1015 *Contrast Enhancement Techniques for LED Displays* for information on contrast enhancement in moderate ambients.

### Controller Circuits, Power Calculations and Display Dimming

Refer to Application Note 1016 *Using the HDSP-2000 Alphanumeric Display Family* for information on controller circuits to drive these displays, how to do power calculations and a technique for display dimming.