



ELECTRONICS

Product Information

ISSUE DATE : 04-01-30

MODEL : LTS280Q1-PE1

Note : This product information is subject to change without any notice.

PREPARED BY : AMLCD Mobile Application Engineering Group

Samsung Electronics Co . , LTD.



Revision History

Data	Rev. No.	Page	Summary
May. 16. 2003	000		Rev.000 was issued.
Aug. 21. 2003	001		TBD item was defined
Dec. 01. 2003	002	3	Change Storage Temperature SPEC(- 20℃ → - 30℃)
			Change Operating Temperature SPEC(- 10℃ → - 20℃)
		4	Change Power Supply SPEC
		7	Delete Luminance of White Item(B/L off)
			Define C/R(B/L off)
			Define Color chromaticity(Min, Max)
			Define Viewing Area(Typical)
		13	Change Gate On Voltage (Min, Max)
			Change Gate Off Voltage
			Change Common Voltage (Max)
			Insert Power Sequence Diagrams
			Add Power dissipation check Pattern
		16	Correct TSP Pin Number
18	Add Explanation of Option Pin(CLW1, SDT1)		
19	Correct TSP Pin Description		
23	Change Outline Dimension		
24	Correct Number of panels per pack(40 → 50)		
Jan. 30. 2004	003	7	Change Luminance Spec(Min., Typ.)
		23	Change Outline Dimension

Contents

General Description	-----	(4)
1. Absolute Maximum Ratings	-----	(5)
1.1 Absolute Ratings Of Environment		
1.2 Electrical Absolute Ratings		
2. Optical Characteristics	-----	(7)
3. Electrical Characteristics	-----	(12)
3.1 TFT-LCD Module		
3.2 Back-Light Unit		
4. Touch Screen Panel Specifications	-----	(14)
5. Block Diagram	-----	(15)
5.1 TFT-LCD Block Diagram		
5.2 TFT-LCD Module Schematics		
5.3 Touch Screen Panel		
5.4 Back-light Unit		
6. Input Terminal Pin Assignment	-----	(17)
6.1 TFT-LCD Module		
6.2 Back-Light Unit		
6.3 Touch Screen Panel		
6.4 Input Signal, Basic Display Colors and Gray Scale of Each Colors		
7. Interface Timing	-----	(21)
7.1 Timing Diagrams of Interface Signal		
7.2 AC Characteristic		
8. Outline Dimensions	-----	(23)
8.1 Module Outline Dimensions (Total Assa'y)		
9. Packing	-----	(24)
10. Marking & Others	-----	(25)
11. General Precaution	-----	(26)
11.1 Handling		
11.2 Storage		
11.3 Operation		
11.4 Others		

General Description

* Description

LTS280Q1-PE1 is a transfective type color active matrix TFT (Thin Film Transistor) liquid crystal display (LCD) that uses amorphous silicon TFT as a switching devices. This model is composed of a TFT-LCD module(TFT-LCD panel, driver ICs and FPC), a Back-light unit and a touch screen panel. The resolution of a 2.83" contains 240 x 320 pixels and can display up to 262,144 colors.

* Features

- Transfective type.
- 6 LED Back-light
- Using the Touch Screen Panel(Flim to Glass type)
- Line Inversion mode.
- Low Power Consumption.

* Applications

- Display terminals for PDA application products.
- Smart phone / Game machine / Camcoder.

* General Information

Items	Specification	Unit	Note
Display area	43.2(H) x 57.6(V)	mm	-
Driver element	a-Si TFT active matrix	-	-
Display colors	262,144	colors	-
Number of pixels	240(H) x RGB x 320(V)	pixel	-
Pixel arrangement	RGB vertical stripe	-	-
Pixel pitch	0.180(H) x 0.180(V)	mm	-
Display mode	Normally White	-	-
Viewing Direction	12:00	o'clock	-

* Mechanical Information

Item		Min.	Typ.	Max.	Unit	Note
Model size	Horizontal(H)	52.7	52.9	53.1	mm	(1)
	Vertical(V)	71.5	71.7	71.9	mm	
	Depth(D)		4.75	5.0	mm	
Weight	-	-	38	g		

Note (1) Touch screen panel, FPC and Back-light unit are included.

1. Absolute Maximum Ratings

1.1 Absolute Ratings of Environment

Item	Symbol	Min.	Max.	Unit	Note
Storage temperature	T _{STG}	-30	70	°C	(1),(5)
Operating temperature (Ambient temperature)	T _{OPR}	-20	60	°C	(1),(2),(5)
Vibration (Non - operating)	V _{nop}	10	500	Hz	(3),(4)

Note (1) 90 % RH Max. (40 °C ≥ Ta)

Maximum wet-bulb temperature at 39 °C or less. (Ta > 40 °C) No condensation.

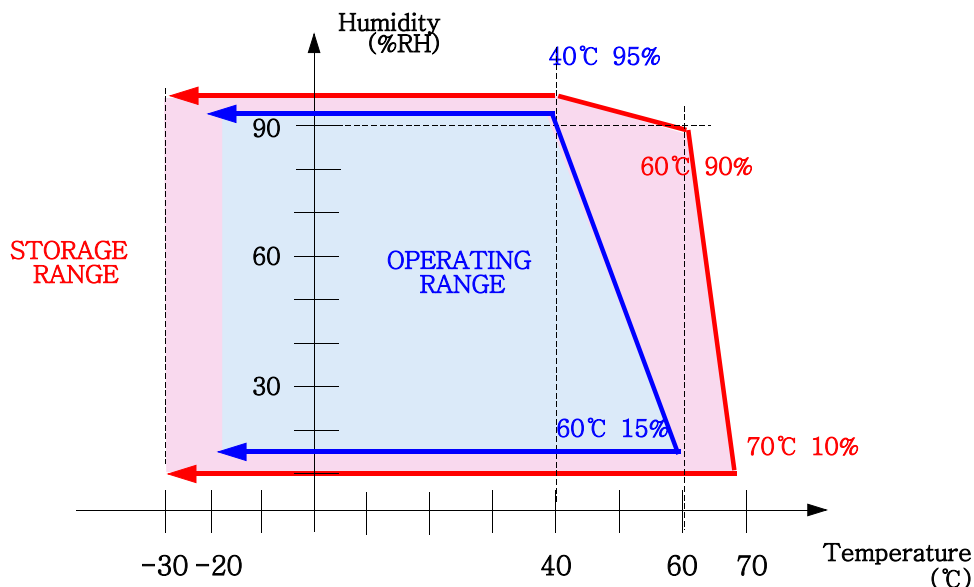

(2) In case of below 0°, the response time of liquid crystal (LC) becomes slower and the color of panel becomes darker than normal one.

Level of retardation depends on temperature, because of LC's characteristics.

(3) (10 ⇔ 500Hz)^{6CYC} 10min/Cycle, 3G_{pk,,} for each X, Y, Z axis.

(4) At testing vibration, the fixture in holding the module to be tested have to be hard and rigid enough so that the module would not be twisted or bent by the fixture.

(5) If product is exposed to high temperatures for extended time, there is a possibility of the polarizer film damage which could degrade the optical characteristics.

1.2 Electrical Absolute Ratings

(1) TFT-LCD Module

(Ta = Room Temp, V_{ss}=GND=0V)

Characteristics	Symbol	Min.	Max.	Unit	Note
Power supply(analog, digital)	V _{DD}	2.7	3.6	V	-
Power supply(gate on)	V _{ON}	13	17	V	-
Power supply(gate off)	V _{OFF}	-11	-7	V	-
Common Voltage	V _{COM}	-0.3	5.5	V	DC
Input voltage	V _I	-0.3	V _{DD} + 0.3	V	-

(2) Back-Light Unit

(Ta = Room Temp)

Characteristics	Symbol	Min.	Max.	Unit	Note
Current	I _B	-	25	mA	(1)

Note (1) Permanent damage to the device may occur if maximum values are exceeded or reverse voltage is loaded.

Functional operation should be restricted to the conditions described under normal operating conditions.

2. Optical Characteristics

The following items are measured under stable conditions. The optical characteristics should be measured in a dark room or equivalent state with the methods shown in Note (3), (4).

Measuring equipment: LCD-7200, BM-5A, BM-7, PR-650, EZ-Contrast

*This includes optical characteristics of TSP.

(Ta = Room Temp)

* Optical Characteristics can be changed without special notice

Item	Symbol	Condition	Min.	Typ.	Max.	Unit	Note		
Reflectance	Rf	B/L Off	4	7	-	%	(5) LCD-7200		
Contrast ratio (Center point)	C/R1	B/L On	100	150	-	-	(6) BM-5A		
	C/R2	B/L Off	3	6	-	-	(6) LCD-7200		
Luminance of white (Center point)	YL	B/L On	80	110	-	cd/m2	(7) BM-5A		
White uniformity	Uw	B/L On	70	-	-	%	(9) BM-5A		
Response time	Rising:Tr	Tr+Tf	B/L On	-	35	50	msec	(8) BM-7	
	Falling:Tf		B/L Off						
Color chromaticity (CIE 1931)	White	Wx1	B/L On	0.210	0.310	0.410	-	(9) PR-650	
				Wy1	0.230	0.330			0.430
	White	Wx1	B/L Off	0.210	0.310	0.410		(10) LCD-7200	
				Wy1	0.250	0.350			0.450
Viewing angle	Hor.	$\theta L1$	$C/R \geq 10$	40	50	-	Degrees	(11) Ez-Contrast	
		$\theta R1$		30	40	-			
	Ver.	$\phi H1$	B/L On	30	40	-			
		$\phi L1$		40	50	-			
	Hor.	$\theta L2$	$C/R \geq 2$	B/L Off	40	50		-	(11) LCD-7200
		$\theta R2$			40	50		-	
Ver.	$\phi H2$	B/L Off	B/L Off	40	50	-			
	$\phi L2$			40	50	-			

Note (1) The optical characteristics is measured with Back-light and Touch screen panel.

(2) If product is exposed to high temperatures for extended time, there is a possibility of the polarizer film damage which could degrade the optical characteristics.

Note (3) Test Equipment Setup for the Transmissive Mode (Back-light On)

After stabilizing and leaving the panel alone at a given temperature for 30 min , the measurement should be executed. Measurement should be executed in a stable, windless, and dark room. 30 min after lighting the back-light. This should be measured in the center of screen.

- Back-light Current : 15mA
- Back-Light On condition

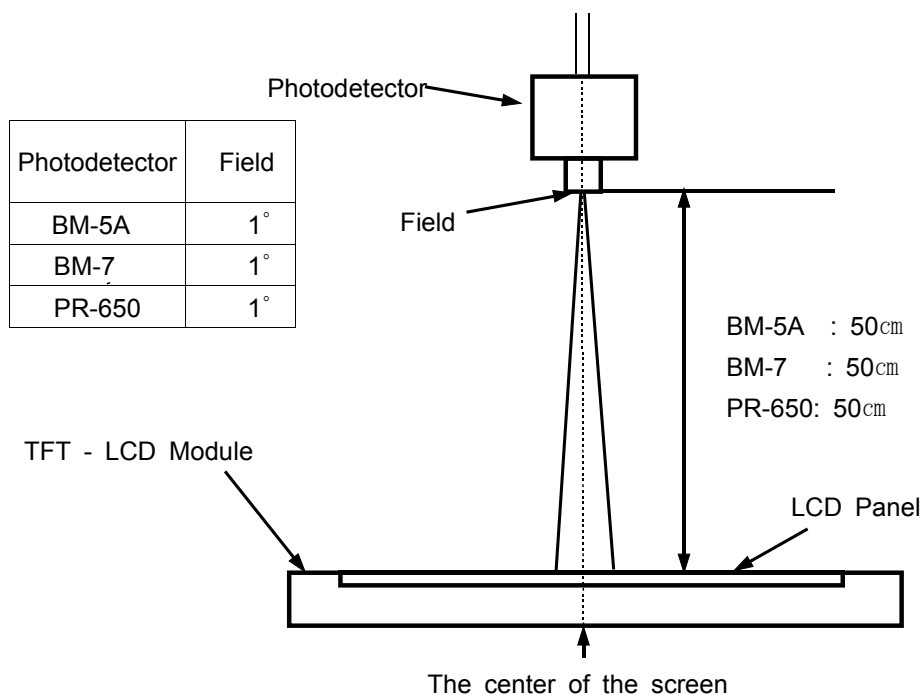

Note (4) Test Equipment Setup for the Reflective Mode (Back-light Off)

After stabilizing and leaving the panel alone at a given temperature for 30min, the measurement should be executed. Measurement should be executed in a stable, windless, and dark room. 30min after lighting of reference light source. The reflected light intensity should be measured in the center of screen. The incident angle of the light source is 30° to the normal direction where the photodetector is positioned.

- Back-Light Off Condition

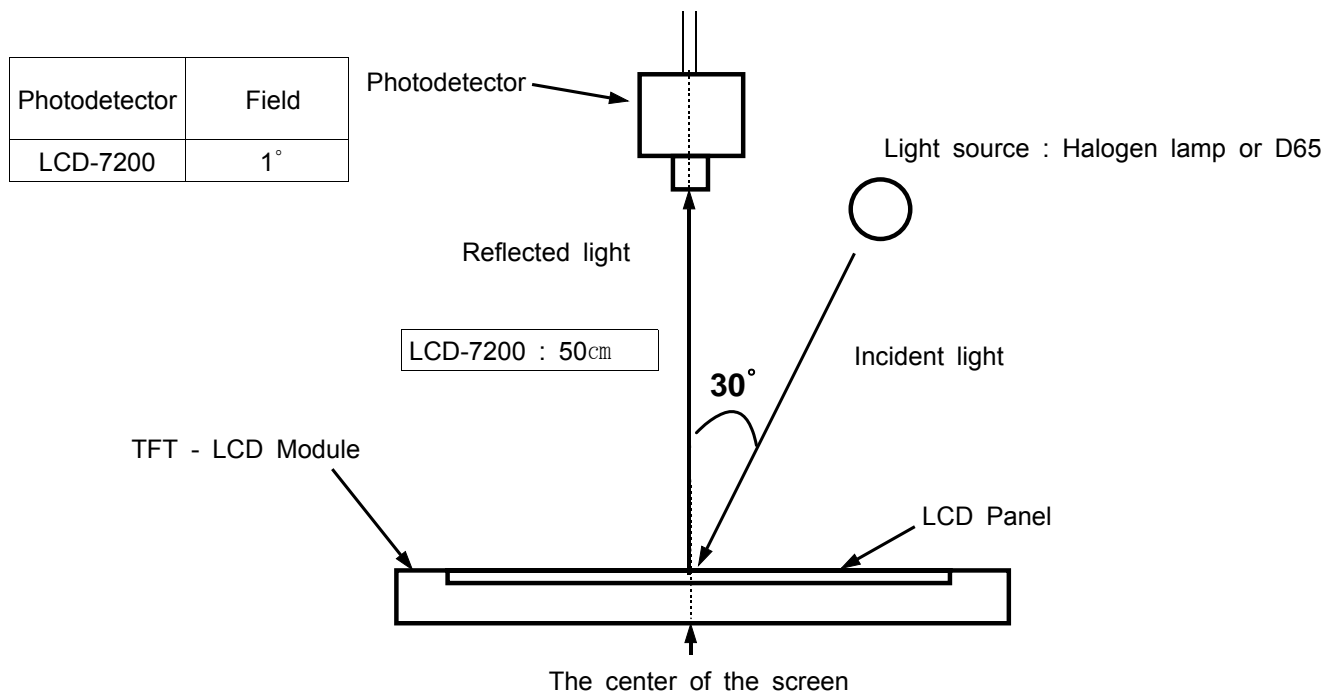

Note (5) Definition of Reflectance : The reflectance is relative quantity to the standard white BaSO₄ or MgO plate that the reflectance of the standard white plate is the 100%.

$$\text{Reflectance} = \frac{\frac{\text{Intensity of the reflected light on LCD}}{\text{Intensity of the incident light on BaSO}_4 \text{ plate}}}{\frac{\text{Intensity of the reflected light on BaSO}_4 \text{ plate}}{\text{Intensity of the incident light on BaSO}_4 \text{ plate}}} \times 100\%$$

Note (6) Definition of Contrast Ratio (C/R) : Ratio of gray max (Gmax) & gray min (Gmin) at the center point of the panel. If Back-light is on state, it is the light source and the BM-5A will be used to measure.

$$C/R = \frac{G_{\max}}{G_{\min}}$$

* Gmax : Luminance with all pixels white
 * Gmin : Luminance with all pixels black

Note (7) Definition of Luminance of White : Luminance of white at center point.
 In this case, the incident light is not from the light source but from the Back-light that generates the reflected light source on LCD in the dark room.

Note (8) Definition of Response time : Sum of Tr ,Tf

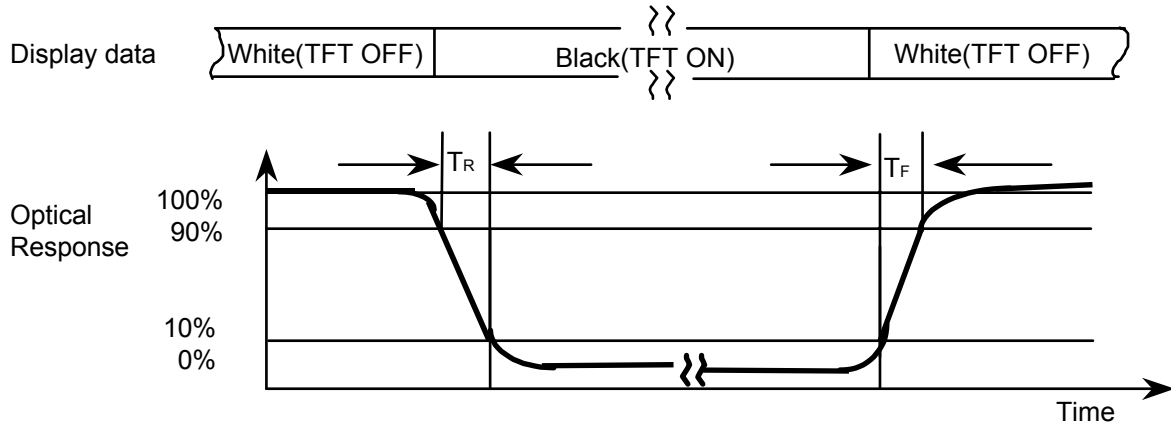

Note (9) Definition of Color Chromaticity (CIE 1931), (Back-light: On)

Note (10) Definition of Color Chromaticity (CIE 1931), (Back-light: Off)

Color coordinate of white at center point.

It should be measured at vertical direction on Back-light off state

* Light Source : D65.

Note (11) Definition of Viewing Angle : Viewing angle range (CR≥2)

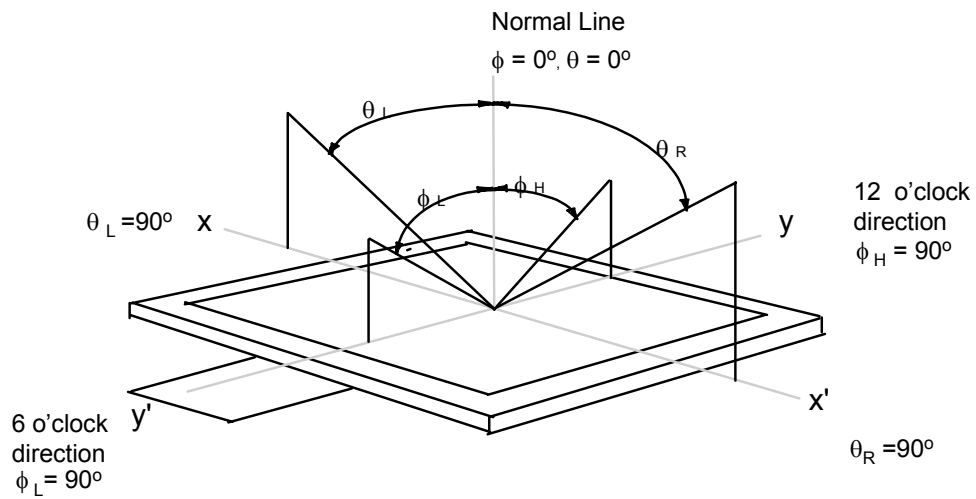

3. Electrical Characteristics

3.1 TFT-LCD Module

(Input Voltage = 3.3V, Ta = Room Temp)

Characteristics		Symbol	MIN.	TYP.	MAX.	Unit	Note
Digital supply voltage		DVDD	3.0	3.3	3.6	V	
Analog supply voltage		AVDD	4.5	5	5.5	V	
Gate On voltage		VON	14	15	16	V	
Gate Off voltage		VOFF	-11	-10	-9	V	
Common voltage		VCOMH (Vpp)	3.5	4.3	5.0	V	
Digital supply current		IDVDD	-	1.1	2.0	mA	
Analog supply current		IAVDD	-	6.3	10.0	mA	
Gate supply current		IVON/ VOFF	-	0.3	0.5	mA	
Input voltage	Source driver (High)	VIHS	0.8DVDD	-	DVDD	V	
	Source driver (Low)	VILS	GND	-	0.2DVDD	V	
Power Dissipation	White	PW	-	30	40	mW	(1),(2)
	Black	PB	-	45	55	mW	
	Vertical Stripe	PV	-	40	50	mW	

* To prevent a latch-up or DC operation of the LCD module, the power on/off sequence should be as below.

- Power On : DV_{DD} → AV_{DD} → V_{OFF} → V_{ON} → Data
- Power Off : Data → V_{ON} → V_{OFF} → AV_{DD} → DV_{DD}

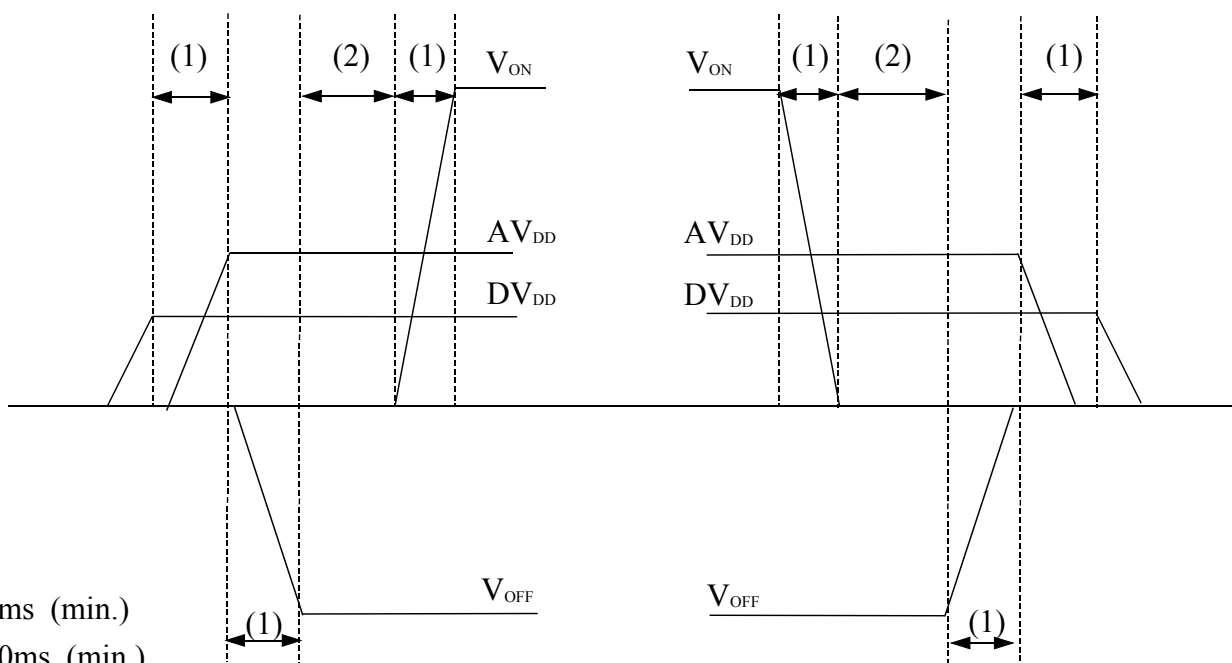

Note (1) Condition : TFT-LCD module only with typ. electrical characteristics

(2) Power dissipation check pattern

[White patten]

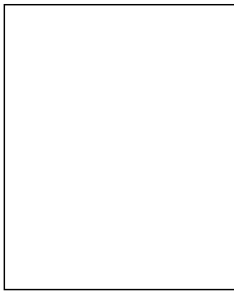

[Black patten]

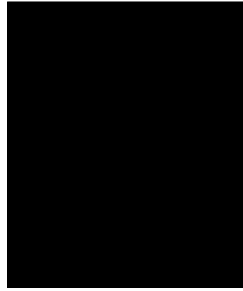

[Vertical Stripe patten]

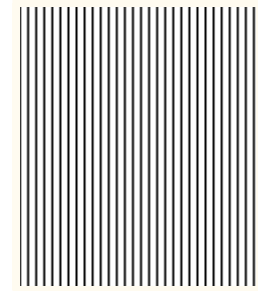

3.2 Back-Light Unit

The Back-light system is an edge-lighting type with 6 white LED(Light Emitting Diode)s. The characteristics of 6 white LEDs are shown in the following tables.

(Ta = Room Temp)

Characteristics	Symbol	Min.	Typ.	Max.	Unit	Note
Current	I _B	-	15	25	mA	(1)
Power Consumption	P _{BL}	-	300	500	mW	(2)

Note (1) 6 white LEDs serial type.

(2) Where I_B = 15mA, V_B = 20V, P_{BL} = V_B × I_B

4. Touch Screen Panel Specifications

4-1. Electrical Characteristics

Item	Min.	Typ.	Max.	Unit	Note
Linearity	-1.5	-	1.5	%	Analog X and Y directions
Terminal resistance	200	-	900	Ω	X(Film side)
	200	-	900	Ω	Y(Film side)
Insulation resistance	25	-	-	M Ω	DC 25V
Voltage	-	5	7	V	DC
Chattering	-	8	10	ms	100k Ω pull-up
Transparency	80	83	-	%	-

Caution (1) : Do not operate it with a thing except a polyacetal pen(tip R0.8mm or less) or a finger, especially those with hard or sharp tips such as a ball point pen or a mechanical pencil.

4-2. Mechanical & Reliability Characteristics

Item	Min.	Typ.	Max.	Unit	Note
Activation force	-	15	80	g	(1)
Durability-surface scratching	Write 120,000	-	-	characters	(2)
Durability-surface pitting	1,000,000	-	-	touches	(3)
Durability-chemical	-	-	-	-	(4)
Surface hardness	3	-	-	H	JIS K5400

Note (1) Pen : 80g or less (R0.8mm)

Finger : 80g or less (R8.0mm)

(2) Measurement for Surface area

- Stylus Pen has a 20mm×20mm area

- Force :250g

- Speed : 1000 characters/hour

(3) Each Touch by R0.8mm Stylus pen & 500gf load

(4) After Dropping a drop of Toluene (or Acetone, Methanol, crude Ethanol), brushing with Fabrics for 3 min. Don't be detected uneven point.

5. Block Diagram

5.1 TFT-LCD Block Diagram

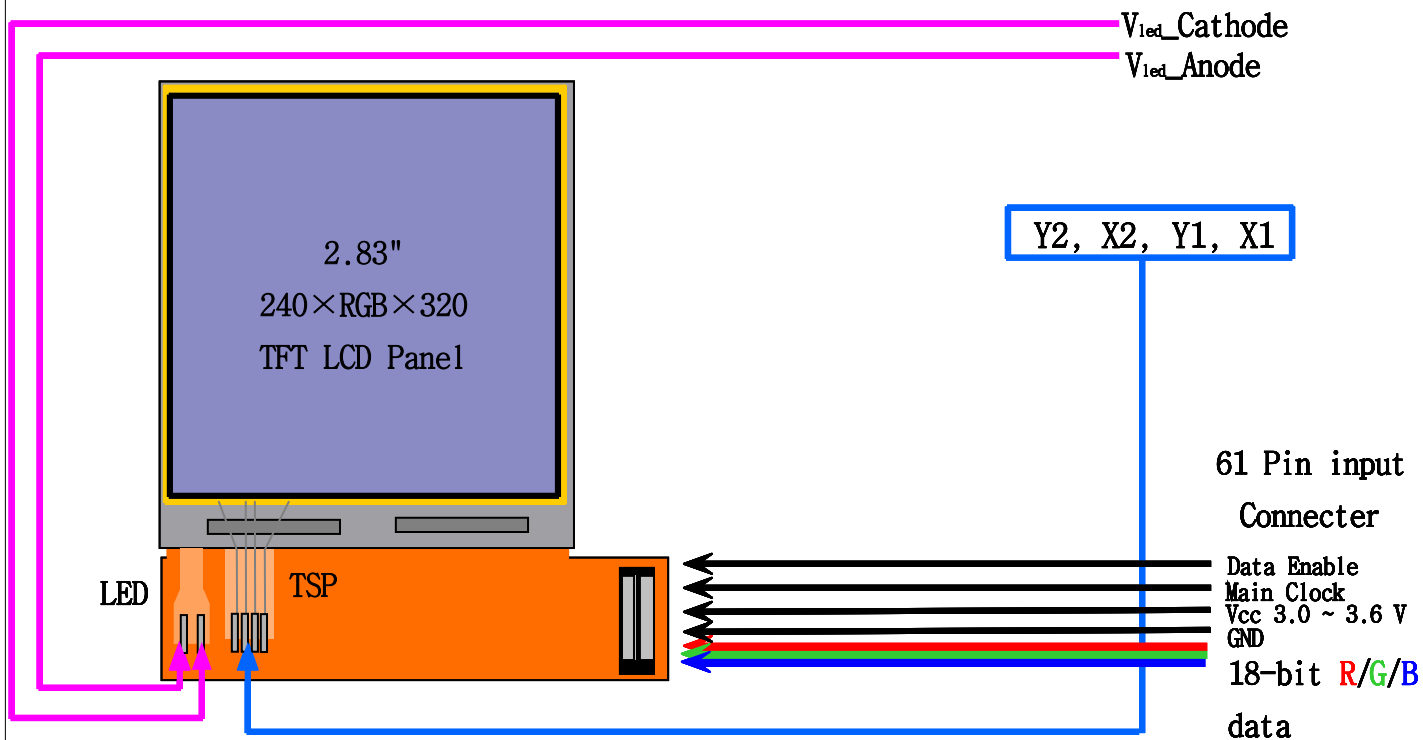

5.2 Touch Screen Panel

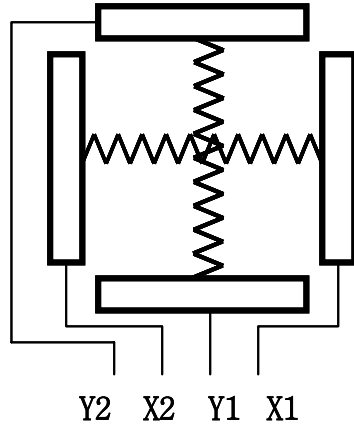

Top View

X : Upper electrode
Y : Lower electrode

5.3 Back-light Unit

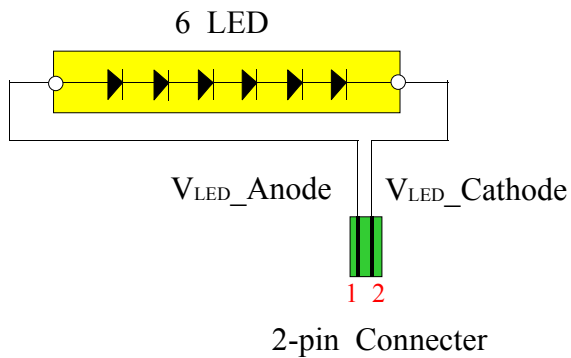

Pin No.	Symbol	I/O
1	LED_ANODE	Anode
2	LED_CATHODE	Cathode

6. Input Terminal Pin Assignment

6.1 TFT-LCD Module (Mating Connector : 61PIN (Part Name:FH23-61S-0.3SHW, HIROSE))

Pin No	Symbol	Description	Remark
1	DE	DATA ENABLE	-
2	MCLK	MAIN CLOCK	-
3	ENABLE	IC RESET	-
4	TSP1	TSP Interface Signal Y2	-
5	VSS	DIGITAL ground	-
6	VCOM	Common Voltage	-
7	VCOM	Common Voltage	-
8	AVSS	ANALOG ground	-
9	VOFF	Gate off Voltage	-
10	VOFF	Gate off Voltage	-
11	VON	Gate on Voltage	-
12	VON	Gate on Voltage	-
13	VSS	DIGITAL ground	-
14	TSP2	TSP Interface Signal X2	-
15	VCOMR	Input High Level of VCOM	-
16	VCOMS	OUTPUT	-
17	VCOMS	OUTPUT	-
18	VCOMC	Test pin	-
19	AVSS	Analog ground	-
20	VDD	Logic Power	-
21	VDD	Logic Power	-
22	AVDD	Analog Power	-
23	AVDD	Analog Power	-
24	TSP3	TSP Interface Signal Y1	-
25	VSS	DIGITAL ground	-
26	CLW1	IC OPTION	(1)
27	TSP4	TSP Interface Signal X1	-
28	SDT1	IC OPTION	(1)
29	PD17	R5	(2)
30	PD16	R4	
31	PD15	R3	
32	PD14	R2	
33	PD13	R1	
34	PD12	R0	

Pin No	Symbol	Description	Remark
35	PD11	G5	(2)
36	PD10	G4	
37	PD9	G3	
38	PD8	G2	
39	PD7	G1	
40	PD6	G0	
41	PD5	B5	
42	PD4	B4	
43	PD3	B3	
44	PD2	B2	
45	PD1	B1	
46	PD0	B0	
47	VREF4P	Gamma Voltage (Positive)	-
48	VREF3P	Gamma Voltage (Positive)	-
49	VREF2P	Gamma Voltage (Positive)	-
50	VREF1P	Gamma Voltage (Positive)	-
51	VREF0P	Gamma Voltage (Positive)	-
52	VREF4N	Gamma Voltage (Negative)	-
53	VREF3N	Gamma Voltage (Negative)	-
54	VREF2N	Gamma Voltage (Negative)	-
55	VREF1N	Gamma Voltage (Negative)	-
56	VREF0N	Gamma Voltage (Negative)	-
57	MAIN_LED +	LED Power(Anode)	-
58	MAIN_LED +	LED Power(Anode)	-
59	MAIN_LED -	LED Power(Cathode)	-
60	MAIN_LED -	LED Power(Cathode)	-
61	NC	No Connection	-

Remark (1) CLW1 : Set the delay amount of line cycle clock

i . High : 30 clock delay

ii . Low : 0 clock delay

SDT1 : Set the delay amount of source output

i . High : 25 clock delay

ii . Low : 10 clock delay

(2) LSB : PD0, PD6, PD12

MSB : PD5, PD11, PD17

6.2 Back-Light Unit (Connector : 2 pin FPC Solder type)

Pin No.	Symbol	Function
1	LED_ANODE	LED Anode
2	LED_CATHODE	LED Cathode

6.3 Touch Screen Panel (Connector : 4Pin FPC Solder type)

Pin No.	Symbol	I/O	Function
1	X1	Right	Right electrode - differential analog
2	Y1	Bottom	Bottom electrode - differential analog
3	X2	Left	Left electrode - differential analog
4	Y2	Top	Top electrode - differential analog

6.4 Input Signal, Basic Display Colors and Gray Scale of Each Colors

COLOR	DISPLAY	DATA SIGNAL																GRAY SCALE LEVEL	
		RED					GREEN					BLUE							
		R0	R1	R2	R3	R4	R5	G0	G1	G2	G3	G4	G5	B0	B1	B2	B3		B4
BASIC COLOR	BLACK	0	0	0	0	0	0	0	0	0	0	0	0	0	0	0	0	0	-
	BLUE	0	0	0	0	0	0	0	0	0	0	0	1	1	1	1	1	1	-
	GREEN	0	0	0	0	0	0	1	1	1	1	1	1	0	0	0	0	0	-
	CYAN	0	0	0	0	0	0	1	1	1	1	1	1	1	1	1	1	1	-
	RED	1	1	1	1	1	1	0	0	0	0	0	0	0	0	0	0	0	-
	MAGENTA	1	1	1	1	1	1	0	0	0	0	0	0	1	1	1	1	1	-
	YELLOW	1	1	1	1	1	1	1	1	1	1	1	1	0	0	0	0	0	-
	WHITE	1	1	1	1	1	1	1	1	1	1	1	1	1	1	1	1	1	-
GRAY SCALE OF RED	BLACK	0	0	0	0	0	0	0	0	0	0	0	0	0	0	0	0	0	R0
	DARK ↑	1	0	0	0	0	0	0	0	0	0	0	0	0	0	0	0	0	R1
		0	1	0	0	0	0	0	0	0	0	0	0	0	0	0	0	0	R2
		:	:	:	:	:	:	:	:	:	:	:	:	:	:	:	:	:	R3~R60
	:	:	:	:	:	:	:	:	:	:	:	:	:	:	:	:	:		
	LIGHT ↓	1	0	1	1	1	1	0	0	0	0	0	0	0	0	0	0	0	R61
		0	1	1	1	1	1	0	0	0	0	0	0	0	0	0	0	0	R62
	RED	1	1	1	1	1	1	0	0	0	0	0	0	0	0	0	0	0	R63
GRAY SCALE OF GREEN	BLACK	0	0	0	0	0	0	0	0	0	0	0	0	0	0	0	0	0	G0
	DARK ↑	0	0	0	0	0	0	1	0	0	0	0	0	0	0	0	0	0	G1
		0	0	0	0	0	0	0	1	0	0	0	0	0	0	0	0	0	G2
		:	:	:	:	:	:	:	:	:	:	:	:	:	:	:	:	:	G3~G60
	:	:	:	:	:	:	:	:	:	:	:	:	:	:	:	:	:		
	LIGHT ↓	0	0	0	0	0	0	1	0	1	1	1	1	0	0	0	0	0	G61
		0	0	0	0	0	0	0	1	1	1	1	1	0	0	0	0	0	G62
	GREEN	0	0	0	0	0	0	1	1	1	1	1	1	0	0	0	0	0	G63
GRAY SCALE OF BLUE	BLACK	0	0	0	0	0	0	0	0	0	0	0	0	0	0	0	0	0	B0
	DARK ↑	0	0	0	0	0	0	0	0	0	0	0	0	1	0	0	0	0	B1
		0	0	0	0	0	0	0	0	0	0	0	0	0	1	0	0	0	B2
		:	:	:	:	:	:	:	:	:	:	:	:	:	:	:	:	:	B3~B60
	:	:	:	:	:	:	:	:	:	:	:	:	:	:	:	:	:		
	LIGHT ↓	0	0	0	0	0	0	0	0	0	0	0	0	1	0	1	1	1	B61
		0	0	0	0	0	0	0	0	0	0	0	0	0	1	1	1	1	B62
	BLUE	0	0	0	0	0	0	0	0	0	0	0	0	1	1	1	1	1	B63

Note) Definition of Gray :

Rn : Red Gray, Gn : Green Gray, Bn : Blue Gray (n = Gray level)

Input Signal : 0 = Low level voltage, 1 = High level voltage

※R5,G5,B5 : MSB R0,G0,B0 : LSB

7. Interface Timing

7.1 Timing Diagrams of Interface Signal

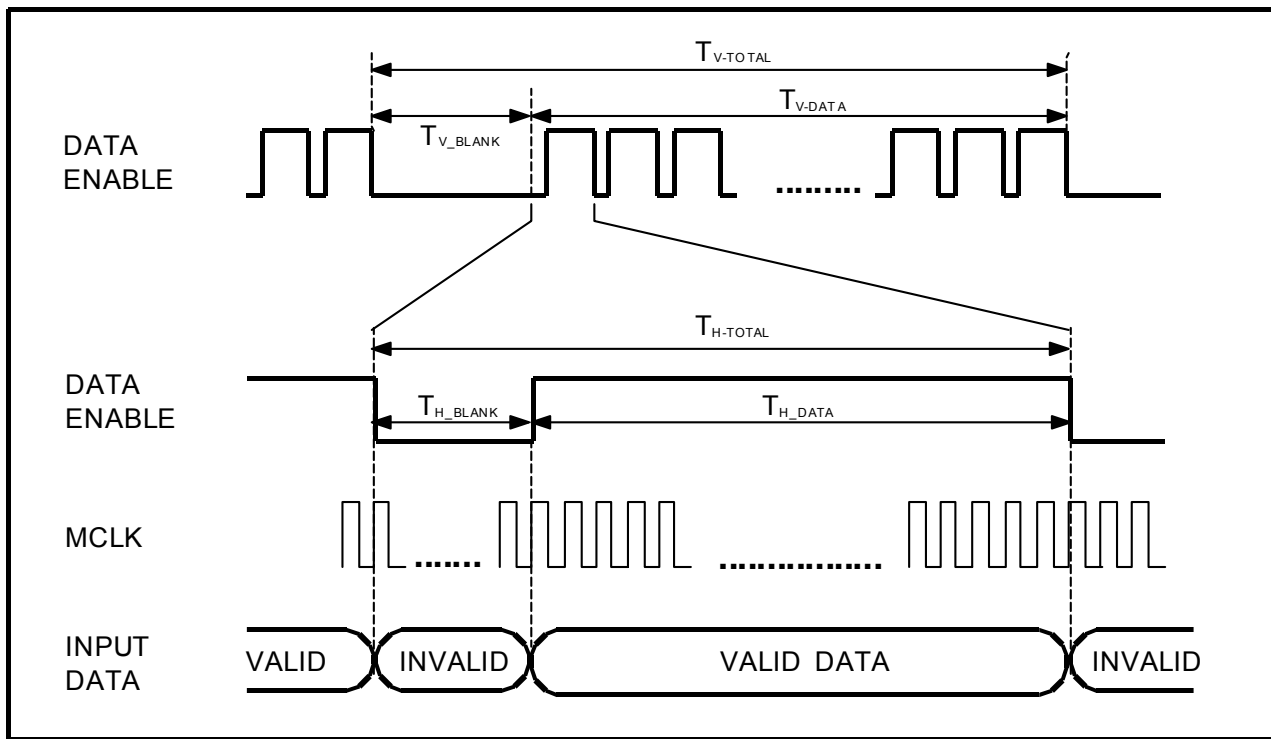

Parameter	Symbol	Minimum	Typical	Maximum	Unit
Vertical Total	T_{V_TOTAL}	327	332	-	Lines
Vertical Blank Time	T_{V_BLANK}	7	12	-	Lines
Vertical Display	T_{V_DATA}	320	320	-	Lines
Horizontal Total	T_{H_TOTAL}	254	266	479	MCLK
Horizontal Blank Time	T_{H_BLANK}	14	26	239	MCLK
Horizontal Display	T_{H_DATA}	240	240	-	MCLK
MCLK	f_{MCLK}	4.98	5.298	-	MHz

7.2 AC Characteristic

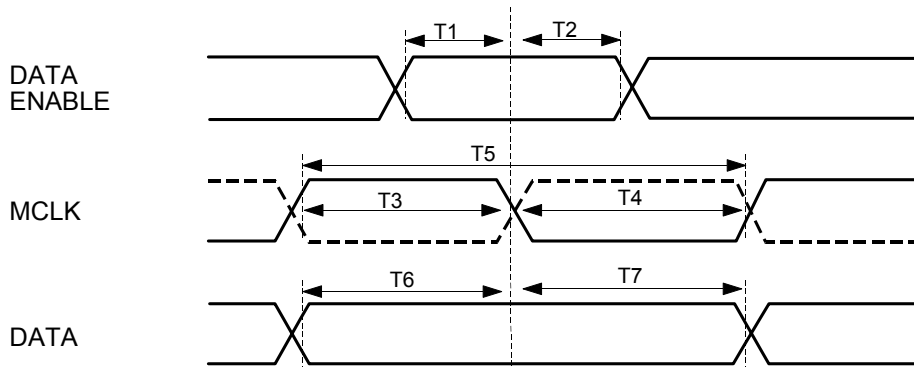

Parameter	Symbol	Min	Typ	Max	Unit
DE Setup	T1	30	-	-	ns
DE Hold	T2	30	-	-	ns
MCLK High Level Pulse	T3	40	-	-	ns
MCLK Low Level Pulse	T4	40	-	-	ns
MCLK Cycle Time	T5	100	-	-	
DATA Setup	T6	30	-	-	ns
DATA Hold	T7	30	-	-	ns
Rising/Falling time		-	-	25	ns
LOGIC INPUT	VIH	0.7×VDD	-	VDD	V
	VIL	0	-	0.3×VDD	V
POWER	VDD	2.5	-	3.6	V

NO	PART NAME	CODE NO	SPECIFICATION	Q'TY	SPEC NO	REMARK
1	OUTLINE-DIMENSION		LTS280Q1-PE1			

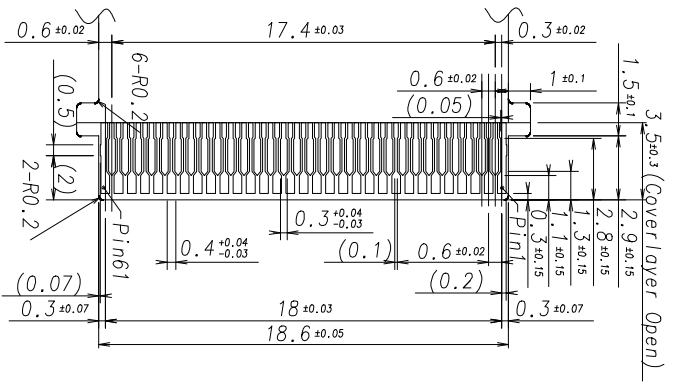
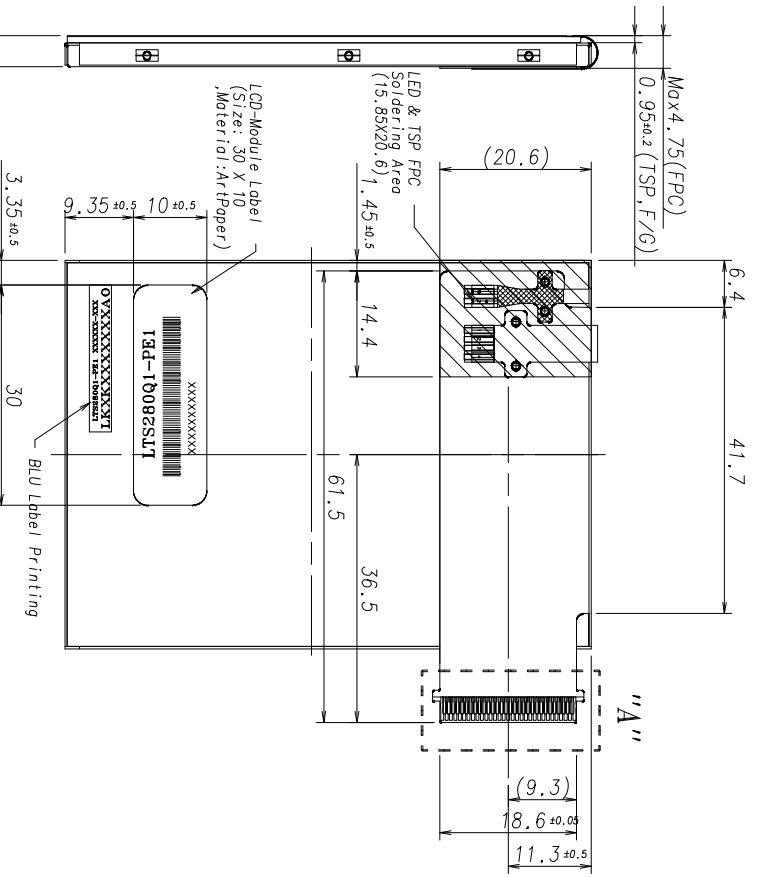
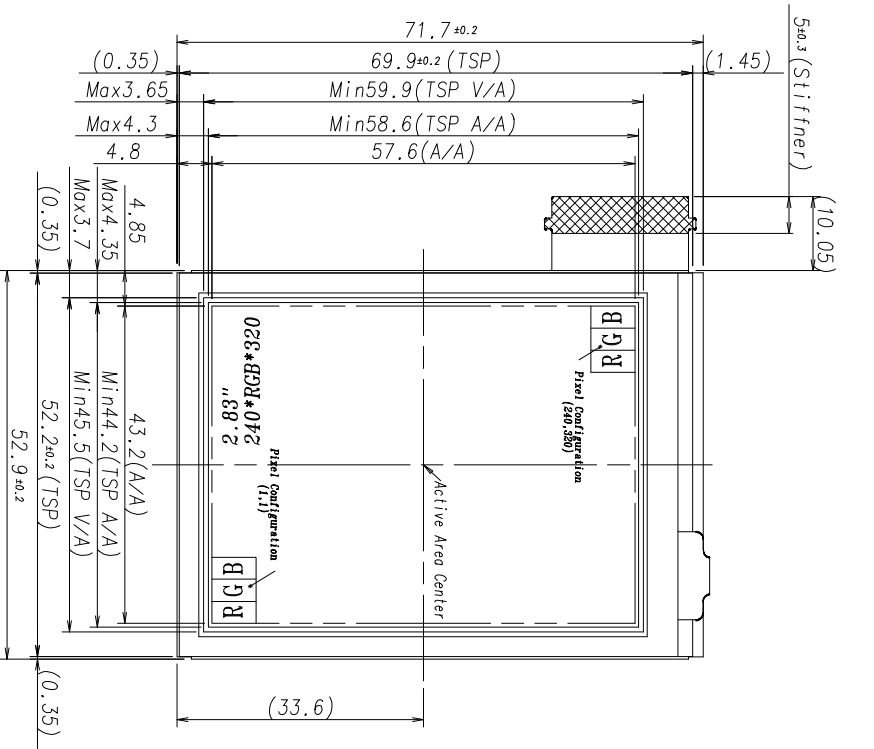

Detail "A" (S=3/1)
PIN ASSIGNMENT

No	Name	No	Name	No	Name	No	Name
1	DE	17	VCOMS2	33	P012	49	VREF 2P
2	MCLK	18	VCOMC	34	P012	50	VREF 1P
3	ENABLE	19	AVSS3	35	P011	51	VREF 0P
4	TS-P1	20	VDD1	36	P010	52	VREF 4N
5	VSS1	21	VDD2	37	P09	53	VREF 3N
6	VCOM1	22	AVDD1	38	P08	54	VREF 2N
7	VCOM2	23	AVDD2	39	P07	55	VREF 1N
8	AVSS1	24	TS-P3	40	P06	56	VREF 0N
9	VDF1	25	VSS2	41	P05	57	MANLEB1
10	VDF2	26	CLWT	42	P04	58	MANLEB2
11	VONT	27	TS-P4	43	P03	59	MANLEB1
12	VON2	28	SOT1	44	P02	60	MANLEB2
13	DVSS2	29	PD17	45	PD1	61	NC
14	TS-P2	30	PD16	46	P00		
15	VCOMR2	31	PD15	47	VREF 4P		
16	VCOMS1	32	PD14	48	VREF 3P		

Note
1. Connector : Hirose FH23-61S-0.3SHW
Number of Pos - 61Pins
2. Unspecified tolerance is the LEVEL3 of General tolerance

PRELIMINARY

GENERAL TOLERANCE			
STEP	LEVEL 1	LEVEL 2	LEVEL 3
0 < X ≤ 4	±0.05	±0.1	±0.2
4 < X ≤ 16	±0.08	±0.15	±0.3
16 < X ≤ 64	±0.12	±0.25	±0.5
64 < X ≤ 256	±0.25	±0.4	±0.8

REV		DATE		DISCRPTION OF REVISION		
UNIT	mm	DRAWN BY	DES'P BY	CHK'D BY	APP'D BY	
	1/1	K. Y. LEE	D. C. KIM	Y. B. CHU		
SCALE		TOLERANCE				
1/1		LEVEL3				
		04.01.30		04.01.30		

MODEL NAME		REASON		CHK'D BY	
LTS280Q1-PE1					
PART/SHEET NAME		OUTLINE DIMENSION SHEET 1/1			
CODE NO.		SPEC. NO.			
		-			

9. Packing

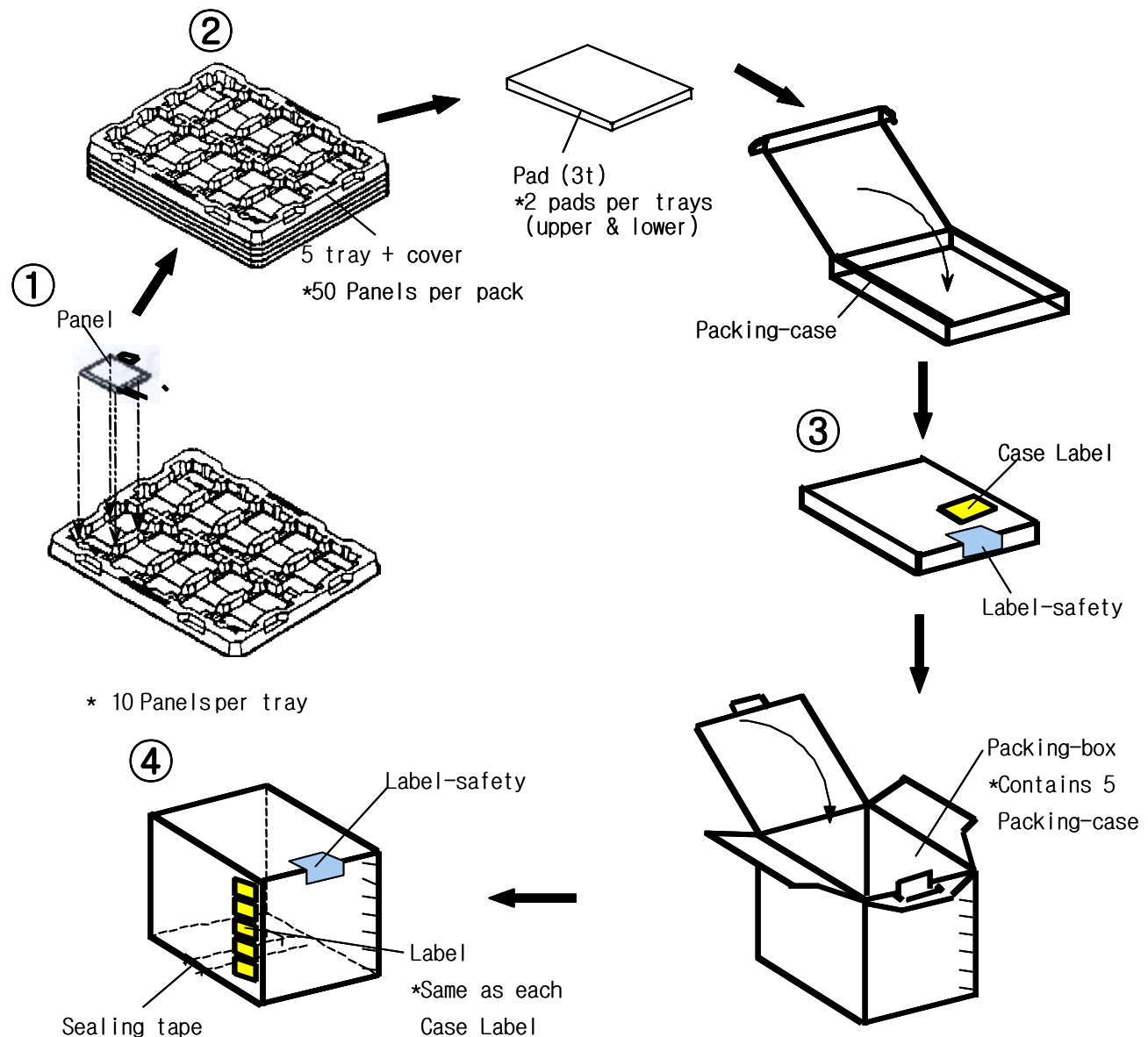

Note (1) Total : Case: Approx. 2.4 Kg

Box: Approx. 12.1 Kg

(2) Size : Case: 490(W) x 342(D) x 58(H)

Box: 505(W) x 355(D) x 319(H)

(3) Pad Material : Polyethylene Foam T=3.0

(4) Resistance of tray surface : $10^3 \sim 10^6 \Omega$

(5) ESD of tray surface : 20~100V

(6) Place the panels in the tray facing the direction shown in the figure.

(7) Place 5 tray and cover(empty tray) and pads inside the packing-case.

(8) Place 5 packing-case inside the packing-box.(Affix the label)

(9) Seal the packing-box. Affix the label-safety.

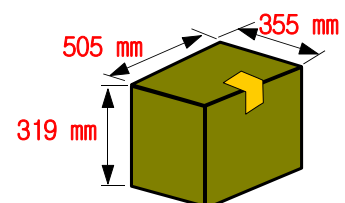

10. Marking & Others

(1) Packing case attach

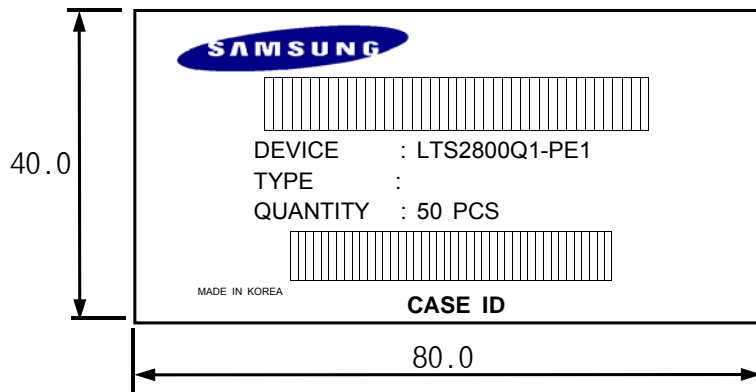

CASE ID : NA 0 00 00001

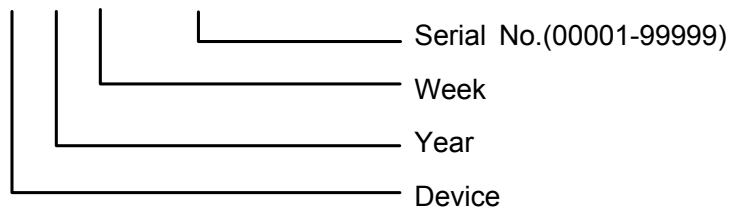

11. General Precautions

11.1 Handling

- (a) When the module is assembled, it should be attached to the system firmly. Be careful not to twist and bend the module.
- (b) Refrain from strong mechanical shock and / or any force to the module. In addition to damage, this may cause improper operation or damage to the module and back-light unit.
- (c) Note that polarizers are very fragile and could be easily damaged. Do not press or scratch the surface harder than a HB pencil lead.
- (d) Wipe off water droplets or oil immediately. If you leave the droplets for a long time, Staining and discoloration may occur.
- (e) If the surface of the polarizer is dirty, clean it using some absorbent cotton or soft cloth.
- (f) The desirable cleaners are water, IPA(Isopropyl Alcohol) or Hexane. Do not use Ketone type materials(ex. Acetone), Ethyl alcohol, Toluene, Ethyl acid or Methyl chloride. It might permanent damage to the polarizer due to chemical reaction.
- (g) If the liquid crystal material leaks from the panel, it should be kept away from the eyes or mouth . In case of contact with hands, legs or clothes, it must be washed away thoroughly with soap.
- (h) Protect the module from static , it may cause damage to the Integrated Gate Circuit.
- (i) Use finger-stalls with soft gloves in order to keep display clean during the incoming inspection and assembly process.
- (j) Do not disassemble the module.
- (k) Protection film for polarizer on the module shall be slowly peeled off just before use so that the electrostatic charge can be minimized.
- (l) Pins of I/F connector shall not be touched directly with bare hands.

11.2 Storage

- (a) Do not leave the panel in high temperature, and high humidity for a long time. It is highly recommended to store the module with temperature from 0 to 35°C and relative humidity of less than 70%.
- (b) Do not store the TFT-LCD module in direct sunlight.
- (c) The module shall be stored in a dark place. It is prohibited to apply sunlight or fluorescent light during the store.

11.3 Operation

- (a) Do not connect, disconnect the module in the "Power On" condition.
- (b) Power supply should always be turned on/off by the item 3.1 "Power on/off sequence"

11.4 Others

- (a) The liquid-crystal is deteriorated by ultraviolet rays. Do not leave it in direct sunlight and strong ultraviolet rays for many hours.
- (b) Avoid condensation of water. It may result in improper operation or disconnection of electrode.
- (c) Do not exceed the absolute maximum rating value. (the supply voltage variation, input voltage variation, variation in part contents and environmental temperature, and so on)
Otherwise the panel may be damaged.
- (d) If the panel displays the same pattern continuously for a long period of time, it can be the situation when the image "Sticks" to the screen.
- (e) This panel has its circuitry FPC on the bottom side and should be handled carefully in order not to be stressed.