

Visible Light Emitting Diode

Features:

- Excellent Optical/Mechanical Axis Alignment
- Designed to interface with External Optics
- High Reliability

Applications:

- Bar-code Scanning
- Fiber Optics



Absolute Maximum Ratings (Ta=25°C)

Items	Symbol	Ratings	Unit
Forward Current (DC)	IF	50	mA
Forward Current (Pulse)*1	IFP	0.5	A
Reverse Voltage	VR	3	V
Power Dissipation	PD	120	mW
Operating Temperature	Topr	-20 ~ +80	°C
Storage Temperature	Tstg	-30 ~ +100	°C
Junction Temperature	Tj	100	°C
Lead Soldering Temp*2	Tsol	260	°C

*1: Tw=10μs, T=10ms

*2: Time 3 Sec max, Position: Up to 2mm from the body.

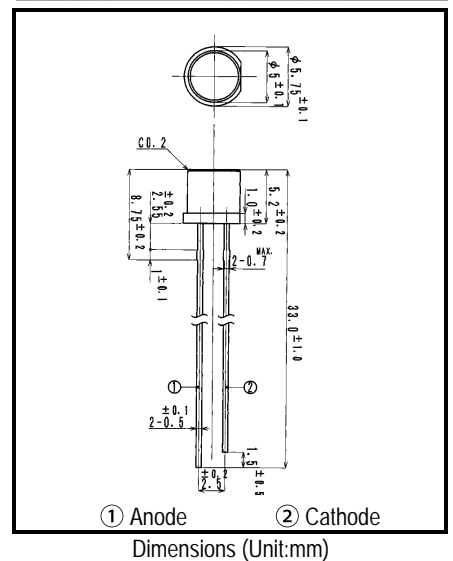

Electrical & Optical Characteristics (Ta = 25°C)

Items	Symbol	Conditions	Min	Typ	Max	Unit
Power Output	PO	IF=20mA	1.00	2.00	--	mW
Forward Voltage	VF	IF=20mA	--	1.7	2.1	V
Reverse Current	IR	VR=5V	--	--	10	μA
Peak Wavelength	λp	IF=20mA	--	700	--	nm
Spectral Line Half Width	Δλ	IF=20mA	--	20	--	nm
Half Intensity Beam Angle	θ	IF=20mA	--	±45	--	deg.
Junction Capacitance	Cj	1MHz, V=0V	--	35	--	pF
Temp. Coefficient of PO	P/T	IF=10mA	--	-0.6	--	%/°C
Temp Coefficient of VF	V/T	IF=10mA	--	-2.0	--	mV/°C

Graphs:

