

isc Silicon PNP Power Transistor

2SB1018A

DESCRIPTION

- Low Collector Saturation Voltage-  
:  $V_{CE(sat)} = -0.5V(Max) @ I_C = -4A$
- High Current Capability-  $I_C = -7A$
- Complement to Type 2SD1411A

APPLICATIONS

- High current switching applications.
- Power amplifier applications.

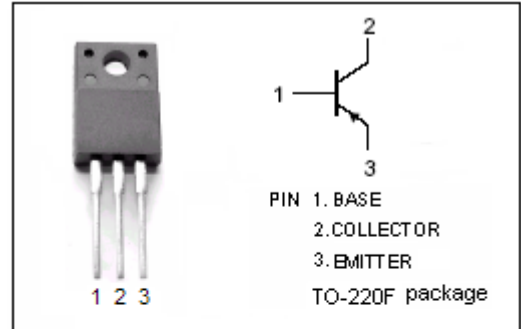

ABSOLUTE MAXIMUM RATINGS( $T_a=25^{\circ}C$ )

SYMBOL	PARAMETER	VALUE	UNIT
$V_{CBO}$	Collector-Base Voltage	-100	V
$V_{CEO}$	Collector-Emitter Voltage	-80	V
$V_{EBO}$	Emitter-Base Voltage	-5	V
$I_C$	Collector Current-Continuous	-7	A
$I_B$	Base Current-Continuous	-1	A
$P_C$	Collector Power Dissipation @ $T_a=25^{\circ}C$	2	W
	Collector Power Dissipation @ $T_C=25^{\circ}C$	30	
$T_J$	Junction Temperature	150	$^{\circ}C$
$T_{stg}$	Storage Temperature Range	-55~150	$^{\circ}C$

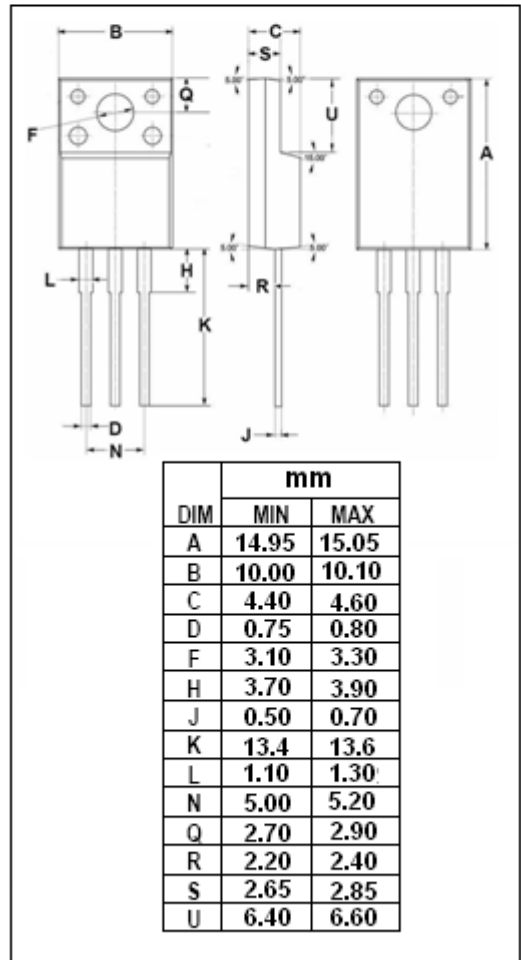

## isc Silicon PNP Power Transistor

## 2SB1018A

## ELECTRICAL CHARACTERISTICS

 $T_C=25^{\circ}\text{C}$  unless otherwise specified

SYMBOL	PARAMETER	CONDITIONS	MIN	TYP.	MAX	UNIT
$V_{(BR)CEO}$	Collector-Emitter Breakdown Voltage	$I_C = -50\text{mA}; I_B = 0$	-80			V
$V_{CE(sat)}$	Collector-Emitter Saturation Voltage	$I_C = -4\text{A}; I_B = -0.4\text{A}$			-0.5	V
$V_{BE(sat)}$	Base-Emitter Saturation Voltage	$I_C = -4\text{A}; I_B = -0.4\text{A}$			-1.4	V
$I_{CBO}$	Collector Cutoff Current	$V_{CB} = -100\text{V}; I_E = 0$			-5	$\mu\text{A}$
$I_{EBO}$	Emitter Cutoff Current	$V_{EB} = -5\text{V}; I_C = 0$			-5	$\mu\text{A}$
$h_{FE-1}$	DC Current Gain	$I_C = -1\text{A}; V_{CE} = -1\text{V}$	70		240	
$h_{FE-2}$	DC Current Gain	$I_C = -4\text{A}; V_{CE} = -1\text{V}$	30			
$C_{OB}$	Output Capacitance	$I_E = 0; V_{CB} = -10\text{V}; f = 1\text{MHz}$		250		pF
$f_T$	Current-Gain—Bandwidth Product	$I_C = -1\text{A}; V_{CE} = -4\text{V}$		10		MHz

## Switching Times

$t_{on}$	Turn-on Time	$I_C = -3.0\text{A}, I_{B1} = -I_{B2} = -0.3\text{A}, V_{CC} = -30\text{V}; R_L = 10\ \Omega$		0.4		$\mu\text{s}$
$t_{stg}$	Storage Time			2.5		$\mu\text{s}$
$t_f$	Fall Time			0.5		$\mu\text{s}$

◆  $h_{FE-1}$  Classifications

O	Y
70-140	120-240