

Product Information

(Preliminary)

ISSUE DATE : 2009-07-10

MODEL : LMS480JC01

PREPARED BY : Mobile Display Division

Samsung Mobile Display Co . , LTD.

Revision History

Data	Rev. No.	Page	Summary
2008.06.04	000		First issued.
2008.06.12	001	p12	Power dissipation changed (Typ. 270mW → 300mW, Max 300mW → 350mW)
2009.07.10	002	p22	Power on/off sepuence
		p23	Module outline dimension

Contents

General Description	-----	(4)
1. Absolute Maximum Ratings	-----	(5)
1.1 Absolute Ratings Of Environment		
1.2 Electrical Absolute Ratings		
2. Optical Characteristics	-----	(7)
2.1 Transmissive Mode		
3. Electrical Characteristics	-----	(12)
3.1 TFT-LCD Module		
3.2 Back-Light Unit		
4. Touch Screen Panel Specification	-----	(14)
4.1 Electrical Characteristics		
4.2 Mechanical & Reliability Characteristics		
4.3 Design Guide		
4.4 Outline Dimension		
5. Block Diagram	-----	(17)
5.1 TFT-LCD Module		
5.2 Back-light Unit		
5.3 Touch Screen Panel		
6. Input Terminal Pin Assignment	-----	(19)
6.1 Input Signal & Power		
6.2 Input Signal, Basic Display Colors and Gray Scale of Each Colors		
7. Interface Timing	-----	(21)
7.1 Timing Parameters of TFT-LCD Module Input Signals		
7.2 Timing Diagrams of TFT-LCD Module Input Signals		
7.3 Power On/Off Sequence		
8. Module Outline Dimension	-----	(23)
9. Packing	-----	(24)
10. Marking & Others	-----	(26)
11. General Precaution	-----	(26)
11.1 Handling		
11.2 Storage		
11.3 Operation		
11.4 Others		

General Description

* Description

LMS480JC01 is a transmissive type color active matrix TFT (Thin Film Transistor) LCD (Liquid Crystal Display) that uses LTPS (Low Temperature Poly-Silicon) TFT as a switching devices. This model is composed of a TFT-LCD module (TFT-LCD panel and FPC). The resolution of a 4.8" contains 1024 x RGB x 600 dots and can display up to 262k colors.

* Features

- LTPS SOG (System-On-Glass) technology
- 4.8 inches 15.4:9 aspect ratio
- WSVGA (1024 x RGB x 600) resolution
- 262k colors (for production only)
- LVDS interface
- TMR (Transmissive with micro-reflectance) display mode
- TN mode with wide viewing angle film
- LED backlight unit
- 4-wire resistive film/glass type touch screen panel (TSP)

* Applications

- Display terminals for Ultra mobile PC (UMPC), Potable CNS

* General Information

Items	Specification	Unit	Note
Display area	104.45(H) x 61.20(V)	mm	-
Driver element	LTPS TFT active matrix	-	-
Display colors	262k	colors	-
Number of dots	1024(H) x 600(V)	dots	-
Pixel arrangement	RGB land	-	-
Dot size	34 x 102	um	-
Display mode	Normally white, TMR mode	-	-
Viewing Direction	12	o'clock	-

* Mechanical Information

Item		Min.	Typ.	Max.	Unit	Note
Model size	Horizontal(H)	111.75	112.05	112.35	mm	w TSP, w Component
	Vertical(V)	72.96	73.26	73.56	mm	w TSP, w Component
	Depth(D)	5.48	5.68	5.88	mm	w TSP, w Component
Weight		-	65	70	g	w TSP, w Component
		-	51	56	g	w/o TSP, w Component

1. Absolute Maximum Ratings

1.1 Absolute Ratings of Environment

Item	Symbol	Min.	Max.	Unit	Note
Storage temperature	T _{STG}	-30	70	°C	(1)
Operating temperature (Ambient temperature)	T _{OPR}	-20	60	°C	(1), (2)

Note (1) 90%RH maximum humidity, 60°C maximum wet-bulb temperature

(2) When operated at a temperature lower than 0°C, the LCD worked slowly and the screen slowed appearing dim images due to the characteristics of LC (Liquid Crystal).

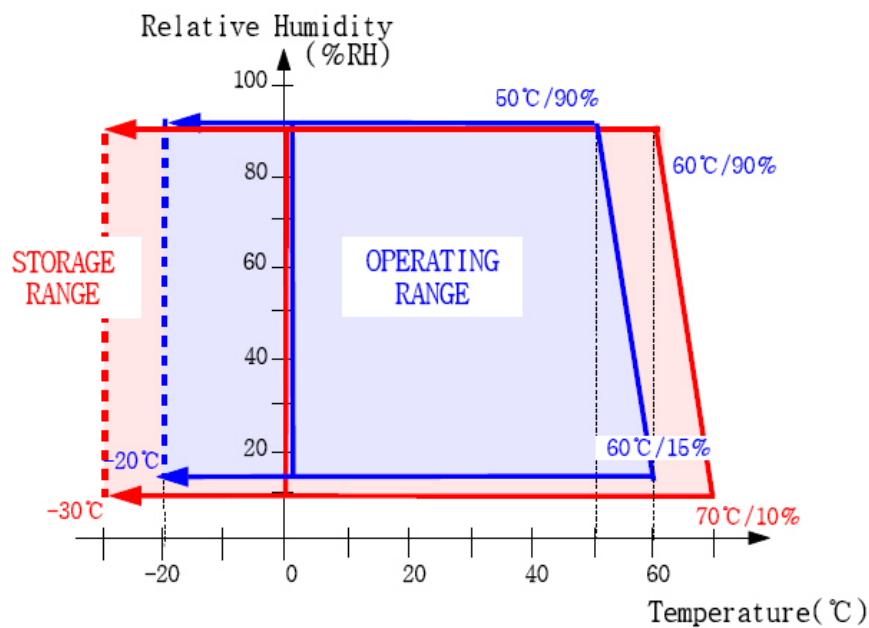

Temperature & Humidity Graph at Absolute Environment

1.2 Electrical Absolute Ratings

(1) TFT-LCD Module

(Ta = 25 ± 2°C, VSS=GND=0V)

Characteristics	Symbol	Min.	Max.	Unit	Note
External power supply	VDD	2.2	3.6	V	

(2) Back-light Unit

(Ta = 25 ± 2°C)

Characteristics	Symbol	Min.	Max.	Unit	Note
Current	I _B	–	25	mA	(1)

Note (1) Permanent damage to the device may occur if maximum values are exceeded or reverse voltage is loaded. Functional operation should be restricted to the conditions described under normal operating conditions.

2. Optical Characteristics

2.1 Transmissive Mode

The following items are measured under stable conditions. The optical characteristics should be measured in a dark room or equivalent state with the methods shown in Note (2).

Measuring equipment: BM-5A, BM-7, PR-650, EZ-Contrast

(Ta = 25 ± 2°C)

Item	Symbol	Condition	Min.	Typ.	Max.	Unit	Note	
Contrast ratio (Center point)	C/R		300	350	–	–	(3) BM-5A	
Luminance of white (Center point)	YL	with TSP	210	280	–	cd/m ²	(4) BM-5A	
Color Reproducibility	Cre		45	50	–	%		
Crosstalk			–	–	5	%	(8) SR-3	
Response time	Rising:Tr	Tr+Tf	–	28	35	msec	(5) BM-7	
	Falling:Tf							
Color chromaticity (CIE 1931)	White	Wx	0.265	0.315	0.365		(6) PR-650	
		Wy	0.293	0.343	0.393			
	Red	Rx	0.540	0.590	0.640			
		Ry	0.279	0.329	0.379			
	Green	Gx	0.289	0.339	0.389			
		Gy	0.533	0.583	0.633			
	Blue	Bx	0.104	0.154	0.204			
		By	0.036	0.086	0.136			
Viewing angle	Hor.	θL	CR≥10	60	65	–	Degrees	(7) EZ- Contrast
		θR		60	65	–		
	Ver.	φH		45	50	–		
		φL		50	55	–		

Note (1) If product is exposed to high temperatures for extended time, there is a possibility of the polarizer film damage which could degrade the optical characteristics.

Note (2) Test Equipment Setup

After stabilizing and leaving the panel alone at a given temperature for 30min, the measurement should be executed. Measurement should be executed in a stable, windless, and dark room. 30min after lighting light source. This should be measured in the center of screen.

- Environment condition : $T_a = 25 \pm 2 \text{ }^\circ\text{C}$
- Back-Light On condition

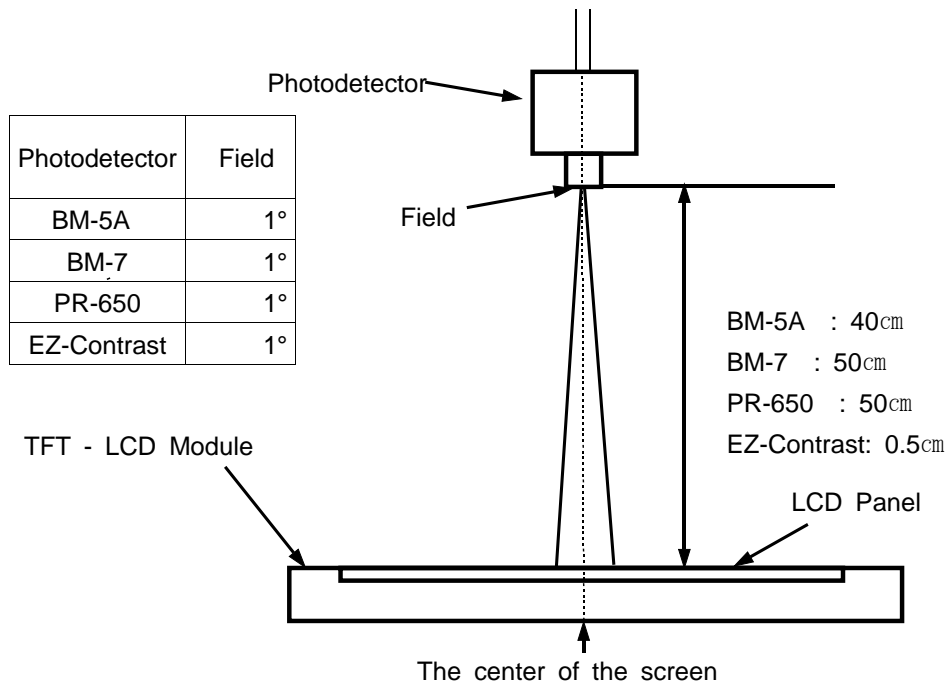

Note (3) Definition of Contrast Ratio (C/R) : Ratio of gray max (Gmax) & gray min (Gmin) at the center point of the panel.

$$C/R = \frac{G_{max}}{G_{min}}$$

* Gmax : Luminance with all pixels white
 * Gmin : Luminance with all pixels black

Note (4) Definition of Luminance of White : Luminance of white at the center point.

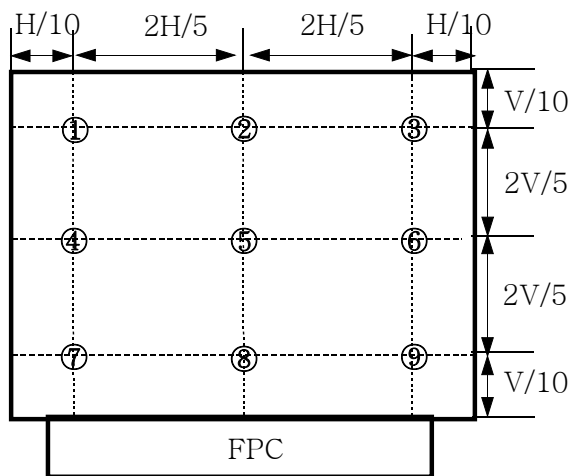

The spot locations for luminance measurement

Note (5) Definition of Response time : Sum of T_r , T_f

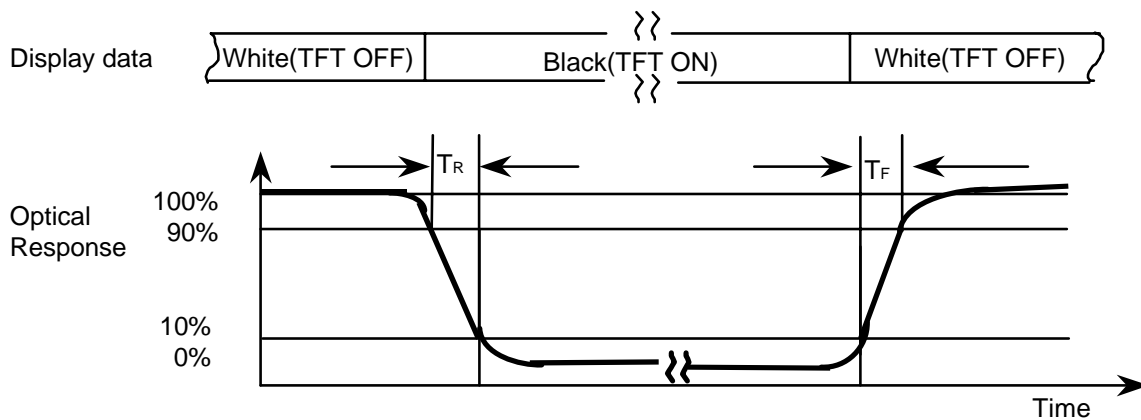

Note (6) Definition of Color Chromaticity (CIE 1931)

Color coordinate of white & red, green, blue at center point.

Note (7) Definition of Viewing Angle

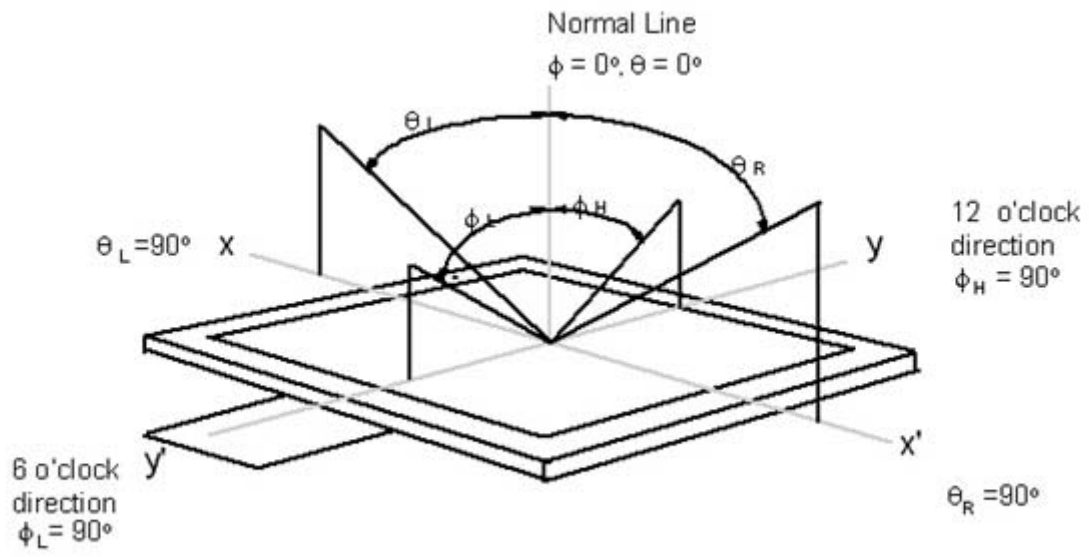

Note (8) Crosstalk

$$\text{Crosstalk Modulation Ratio}(D_{\text{SHA}}) = \frac{|Y_A - Y_B|}{Y_A} \times 100 (\%)$$

Where

Y_A , Y_B measurement = 2° Viewing Angle (Measurement area φ 12mm)

The pattern except the Black Bar is a gray 32.

① Horizontal-Crosstalk measurement method

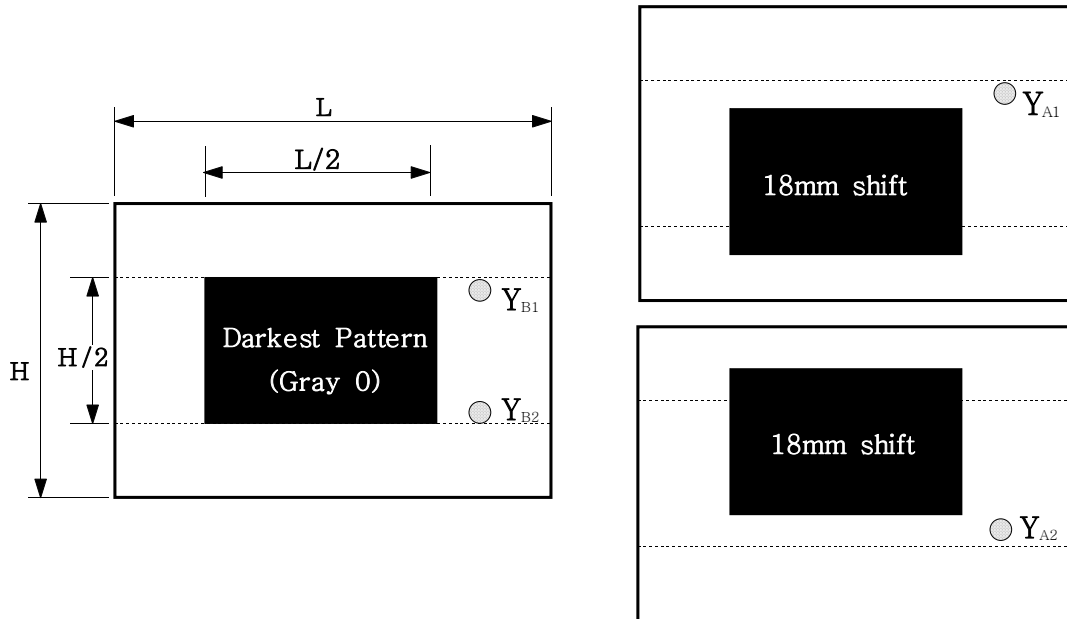

② Vertical-Crosstalk measurement method

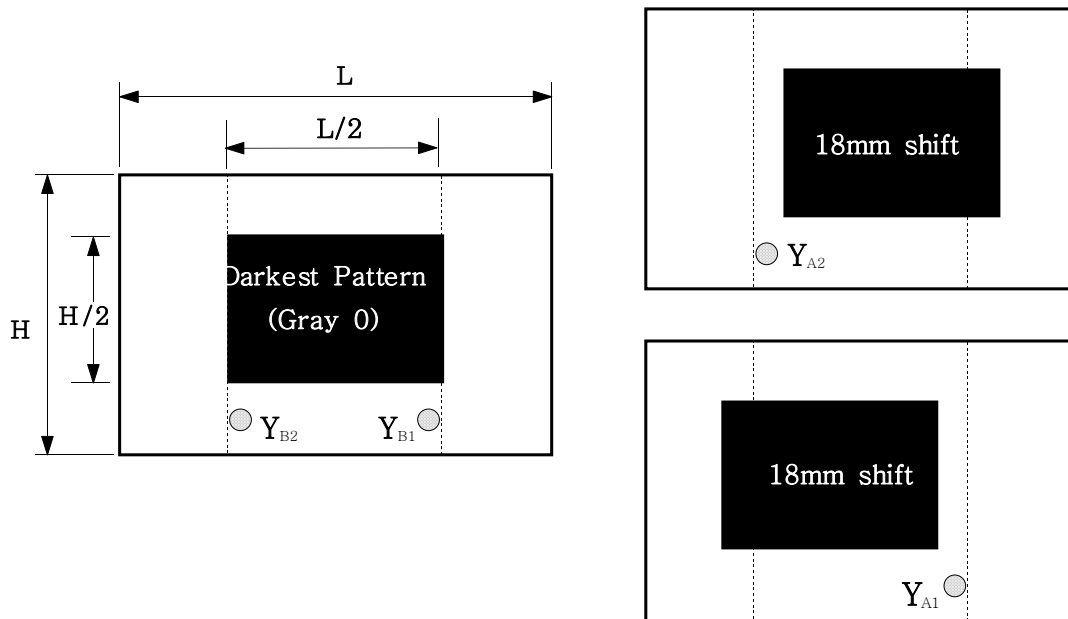

3. Electrical Characteristics

3.1 TFT-LCD Module

* To prevent a latch-up or DC operation of the LCD module, the power on/off sequence should be as the section 7.3 Power On/Off Sequence.

(Ta = 25 ± 2°C)

Characteristics	Symbol	MIN.	TYP.	MAX.	Unit	Note
Logic power supply	VDD	3.2	3.3	3.4	V	
Power Dissipation	White	P _w	300	350	mW	with 1 chip solution
	Black	P _B	300	350		
Frame Frequency	fFRM	60	75	80	Hz	

* Power Dissipation check pattern

a) White Pattern

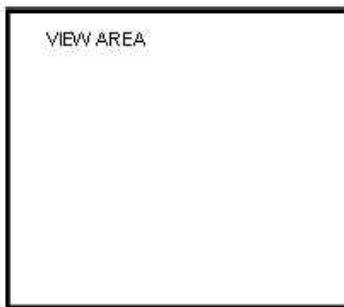

b) Black Pattern

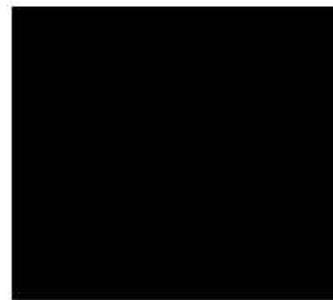

3.2 Back-Light Unit

The back-light system is an edge-lighting type with 11 white LED(Light Emitting Diode)s.

($T_a = 25 \pm 2^\circ\text{C}$)

Characteristics	Symbol	MIN.	TYP.	MAX.	Unit	Note
LEDs current	I_{BL}		20	22	mA	(1)
Power Dissipation	P_{BL}		726	800	mW	(2)

Note (1) 11 white LEDs

Note (2) Where $I_B=20\text{mA}$

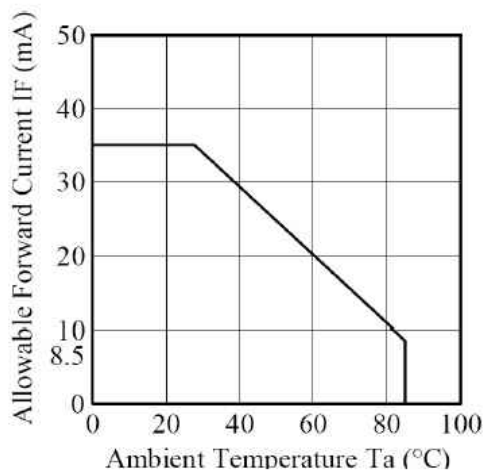

4. Touch Screen Panel Specification

4.1 Electrical characteristic

Characteristics	MIN.	TYP.	MAX.	Unit	Note
Linearity	-1.5	-	1.5	%	Analog X and Y direction
Terminal resistance	360	847	1240	Ω	X
	160	294	640	Ω	Y
Insulation resistance	10	-	-	M Ω	DC 25V
Voltage	-	-	7	V	DC
Chattering	-	-	10	ms	100k Ω pull-up
Transparency	78	80	-	%	JIS-K7105, ASTM D1003, @550nm

Caution (1) : Do not operate it with a thing except a polyacetal pen (tip R0.8mm or more) or a finger, especially those with hard or sharp tips such as a ball point pen or a mechanical pencil.

4.2 Mechanical & Reliability Characteristics

Characteristics	MIN.	TYP.	MAX.	Unit	Note
Activation force	-	-	50	gf	(1)
Linearity force	-	-	130	gf	(2)
Durability (surface scratching)	100,000	-	-	times	(3)
Durability (surface pitting)	1,000,000	-	-	touches	(4)
Surface hardness	3	-	-	H	JIS K7105, ASTM D3363

Note (1) Input method : Stylus pen(R0.8mm)

(2) Input method : Individual point on with stylus pen(R0.8mm)

(3) Measurement for surface area

- Scratch 100,000 times straight line on the film with a stylus change every 20,000 times
- Force : 250gf
- Speed : 60mm/sec
- R0.8 polyacetal tip

(4) Pit 1,000,000 times on the film with a R8.0 silicon rubber.

- Force : 250gf
- Speed : 2 times/sec

4.3 Design Guide

- Give enough clearance (over 0.3mm) between the touch panel and a display device to protect a display.

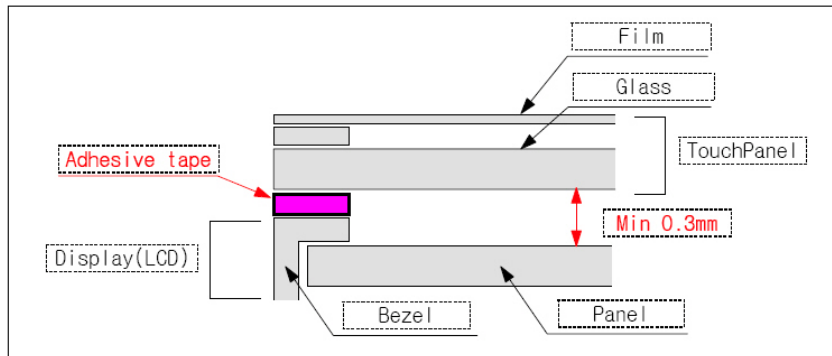

- Avoid the design that Front-case overlap and press on the active area of the touch panel.
- Give enough gap (over 0.5mm at compressed) between the front case and touch panel to protect wrong operating.

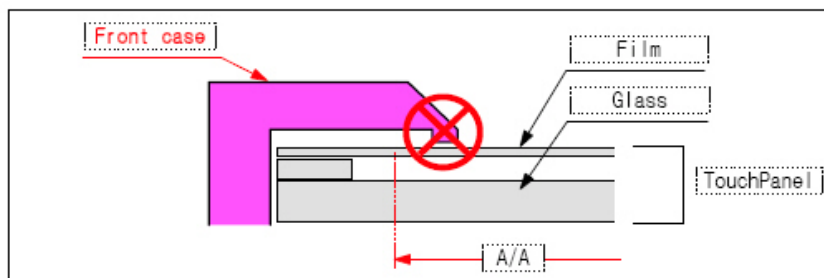

- Use a buffer material (Gasket) between the touch panel and Front-case to protect damage and wrong operating.
- Avoid the design that buffer material overlap and press on the inside of touch panel viewing area.

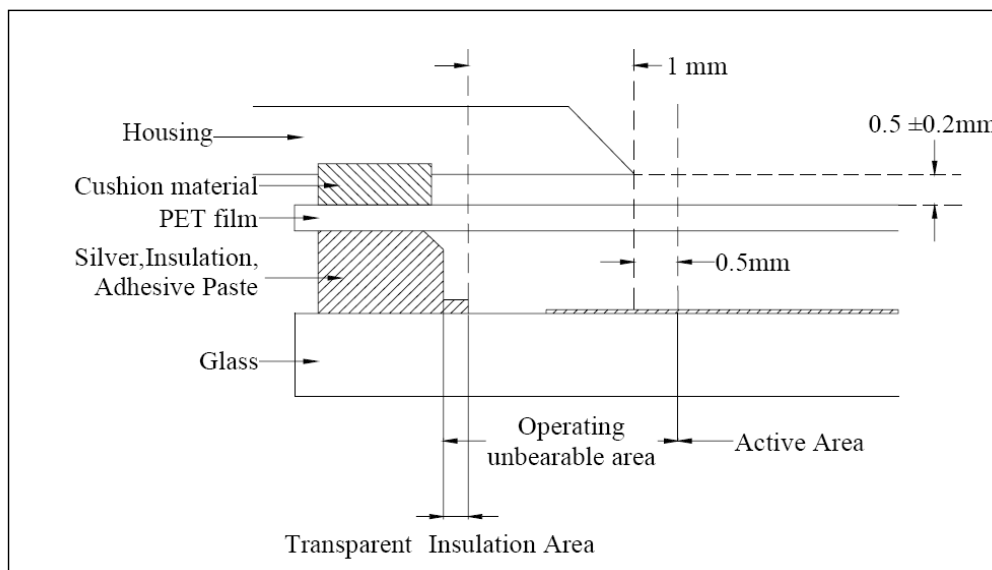

4.4 Outline Dimension

CUSTOMER NAME	Samsung	CUSTOMER Ref. No.		NO.	Revision Record	Reviser	Date
CUSTOMER'S APPROVAL				1.	△ Drawing Revised (3 Point)	Kathy Hsu	05 / 10 / 07
				2.	△ Drawing Revised (2 Point)	Kathy Hsu	05 / 11 / 07
				3.			

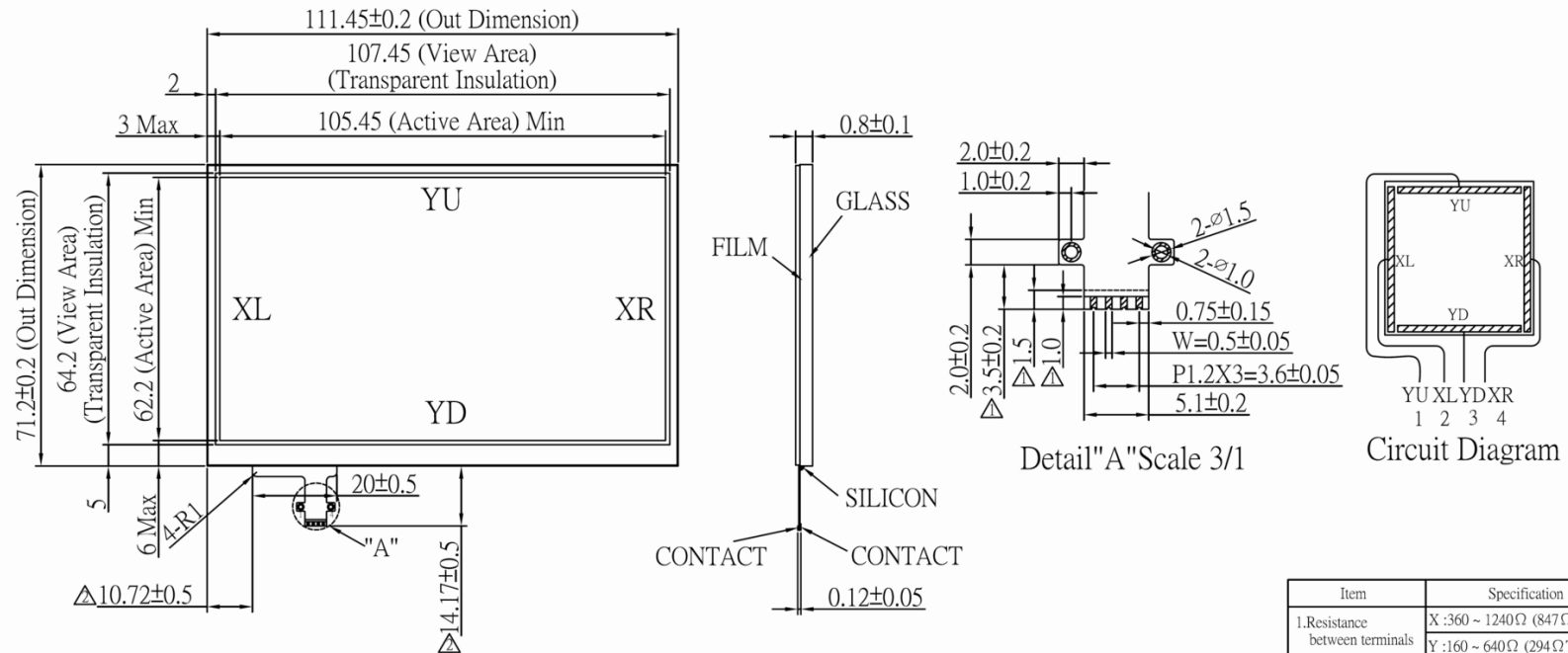

Item	Specification
1. Resistance between terminals	X : 360 ~ 1240 Ω (847 Ω Typ. - Film side) Y : 160 ~ 640 Ω (294 Ω Typ. - Glass side)
2. Linearity	±1.5% ↓
3. Light Transparency	78% Min. (80% Typ.)
4. Surface Hardness	3H
5. Tail	FPC (Copper)

Elucidation	總成圖	Drive Model	Analog	Approved By	Phil Lin	01 / 16 / 07
Panel Size		Drive Voltage		Checked By	Phil Lin	01 / 16 / 07
Viewing Size		Operating Temp		Design By	Kathy Hsu	01 / 16 / 07
Front Material/Thickness	Clear Type/0.18tmm	Storage Temp		Drawing By	Kathy Hsu	01 / 16 / 07
Rear Material/Thickness	Glass/0.55tmm	Connector		Data Reserve		



洋華光電股份有限公司
 YOUNG FAST OPTOELECTRONICS CO.,LTD.
 e - FAST

Sheet	1 / 1	Tolerance	±0.3	Unit	mm
Size	A4	Angles	±0.5°	Scale	1 / X

Pro (3)	
Model Number	
A489B	
Drawing Number	
A489B-01(N2)	

5. Block Diagram

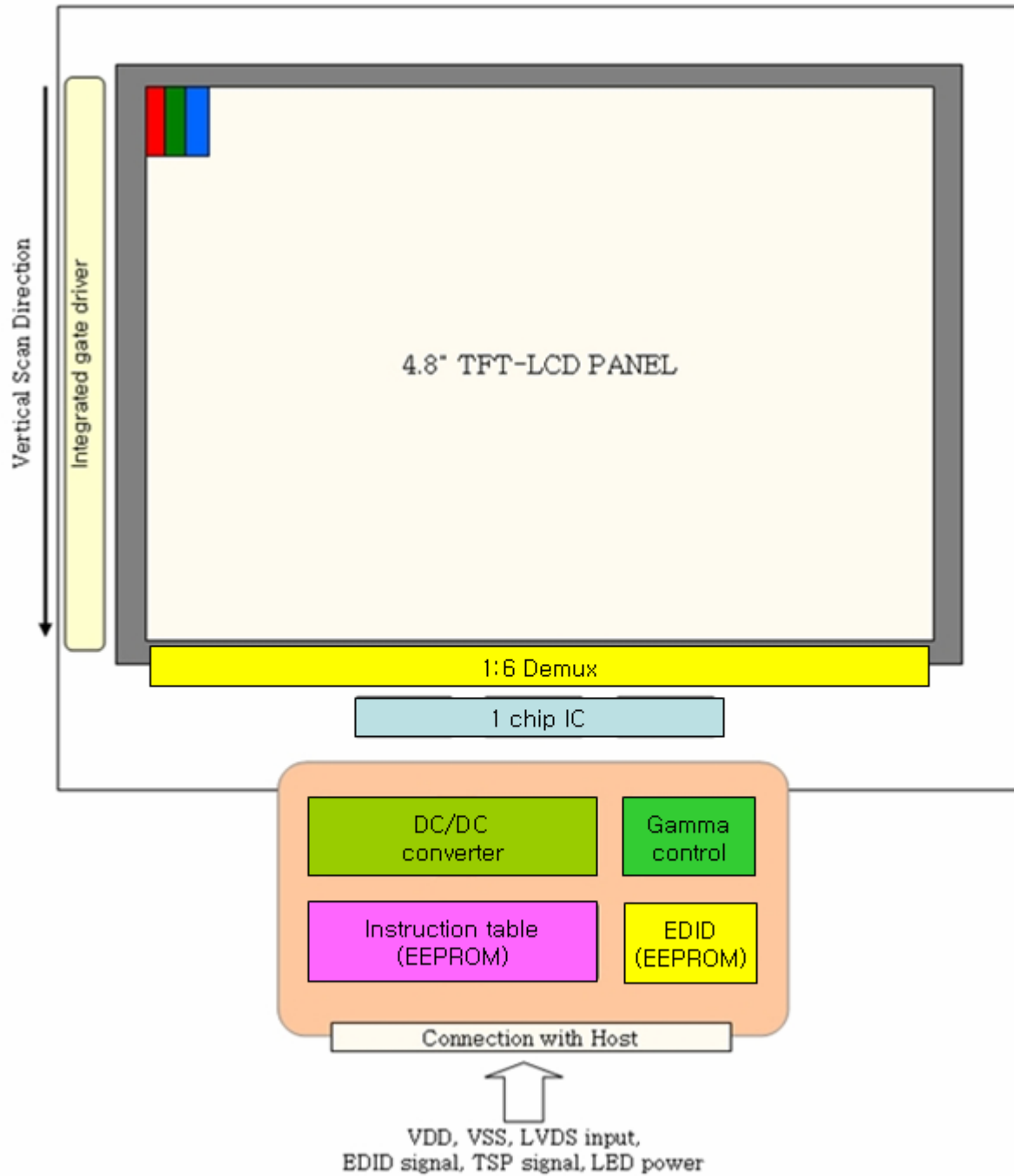
5.1 TFT-LCD Module



5.2 Back-Light Unit (Connector : 4 pin FPC solder type)

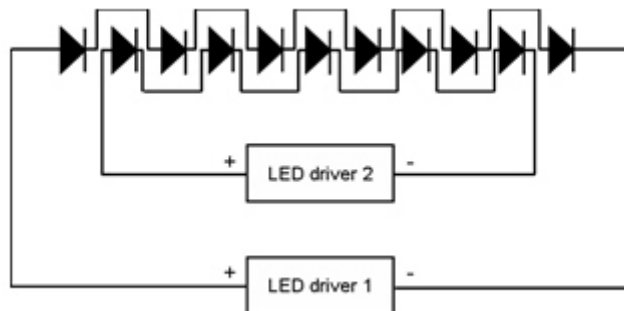

Pin No.	Symbol	I/O
1	VCD1	LED Power supply (cathode-1)
2	VAD1	LED Power supply (anode-1)
3	VAD2	LED Power supply (anode-2)
4	VCD2	LED Power supply (cathode-2)

5.3 Touch Screen Panel

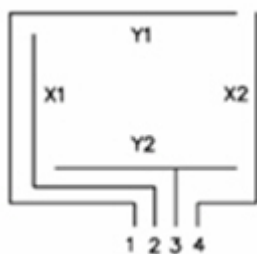

X : Upper electrode, Y : Lower electrode

6. Input Terminal Pin Assignment

6.1 Input Signal & Power (Connector type : 28 pin/ 0.5mm pitch/ Bottom contact)

Pin No.	Symbol	I/O
1	Vdd	LCD Power supply : 3.3V
2	TSPX1	Touch screen signal : X_left
3	TSPX2	Touch screen signal : X_right
4	TSPY1	Touch screen signal : Y_up
5	TSPY2	Touch screen signal : Y_down
6	Vdd	LCD Power supply : 3.3V
7	Vss	Ground
8	RxIN0-	Negative LVDS differential data inputs (R0?R5, G0)
9	RxIN0+	Positive LVDS differential data inputs (R0?R5, G0)
10	Vss	Ground
11	RxIN1-	Negative LVDS differential data inputs (G1?G5, B0- B1)
12	RxIN1+	Positive LVDS differential data inputs (G1?G5, B0- B1)
13	Vss	Ground
14	RxIN2-	Negative LVDS differential data inputs (B2?B5, Hsync, Vsync, DE)
15	RxIN2+	Positive LVDS differential data inputs (B2?B5, Hsync, Vsync, DE)
16	Vss	Ground
17	CLK-	Negative LVDS differential clock inputs
18	CLK+	Positive LVDS differential clock inputs
19	Vss	Ground
20	EDID CLK	EDID clock
21	EDID DATA	EDID data
22	EDID PWR	EDID power supply : 3.3V
23	Vss	Ground
24	Vss	Ground
25	VCD1	LED Power supply (cathode-1)
26	VCD2	LED Power supply (cathode-2)
27	VAD1	LED Power supply (anode-1)
28	VAD2	LED Power supply (anode-2)

7. Interface Timing

7.1 Timing Parameters of TFT-LCD Module Input Signals

(a) Vertical timing

Signal	Symbol	Min.	Typ.	Max.	Unit	Note
Frame Frequency	f_{FRM}	60	75	80	Hz	(1)
VSYNC (Frame) Period	VCYC	-	608	-	H	(1)
VSYNC Low Width	VLW	-	1	-	H	(1)
Vertical Display Period	VDP	-	600	-	H	(1)
Vertical Back Porch	VBP	-	4	-	H	(1)
Vertical Front Porch	VFP	-	3	-	H	(1)

(a) Horizontal timing

Signal	Symbol	Min.	Typ.	Max.	Unit	Note
DotCLK Frequency	f_{CLK}	-	53.99	-	MHz	(1)
HSYNC (Frame) Period	HCYC	-	1184	-	DotCLK	(1)
HSYNC Low Width	HLW	-	32	-	DotCLK	(1)
Horizontal Display Period	HDP	-	1024	-	DotCLK	(1)
Horizontal Back Porch	HBP	-	80	-	DotCLK	(1)
Horizontal Front Porch	HFP	-	48	-	DotCLK	(1)

⁽¹⁾ Timing-combinations have been preset and memorized in EEPROM.

When recommended timings are put into LCD, LCD can be displayed without EDID

7.2 Timing Diagrams of TFT-LCD Module Input Signals

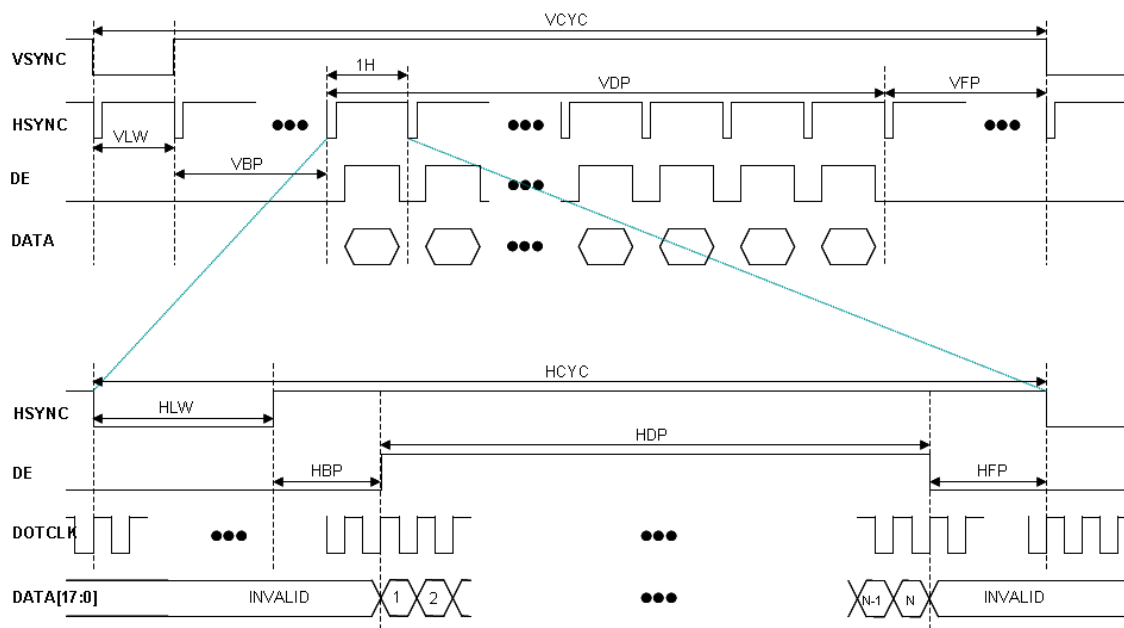

7.3 Power ON/OFF Sequence

– To prevent a latch-up or DC operation of the LCD module, the power on/off sequence should be as the diagram below.

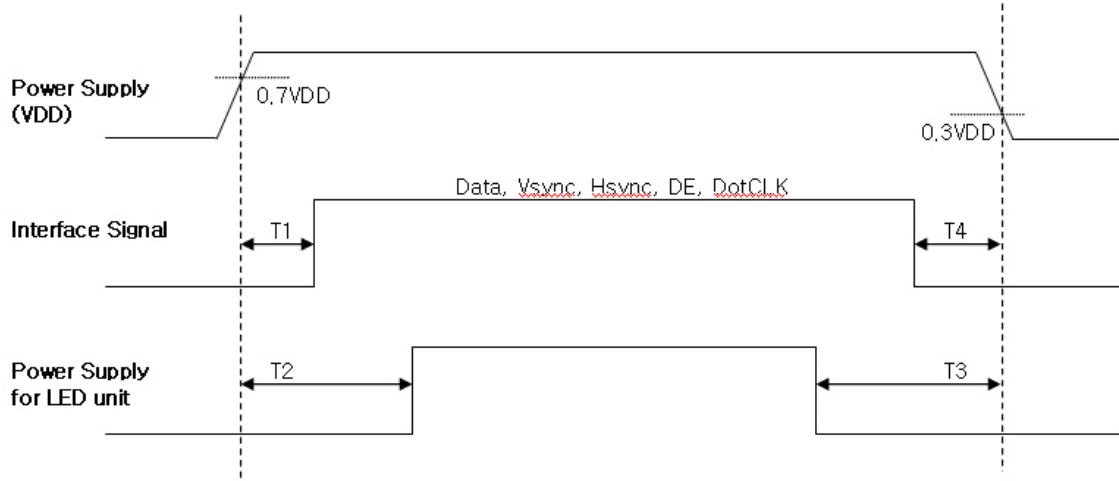

Symbol	Specification	Note
T1	10 ms < T1	
T2	T1 + 300ms < T2	
T3	T4 + 130ms < T3	
T4	10 ms < T4	

8. Module Outline Dimension

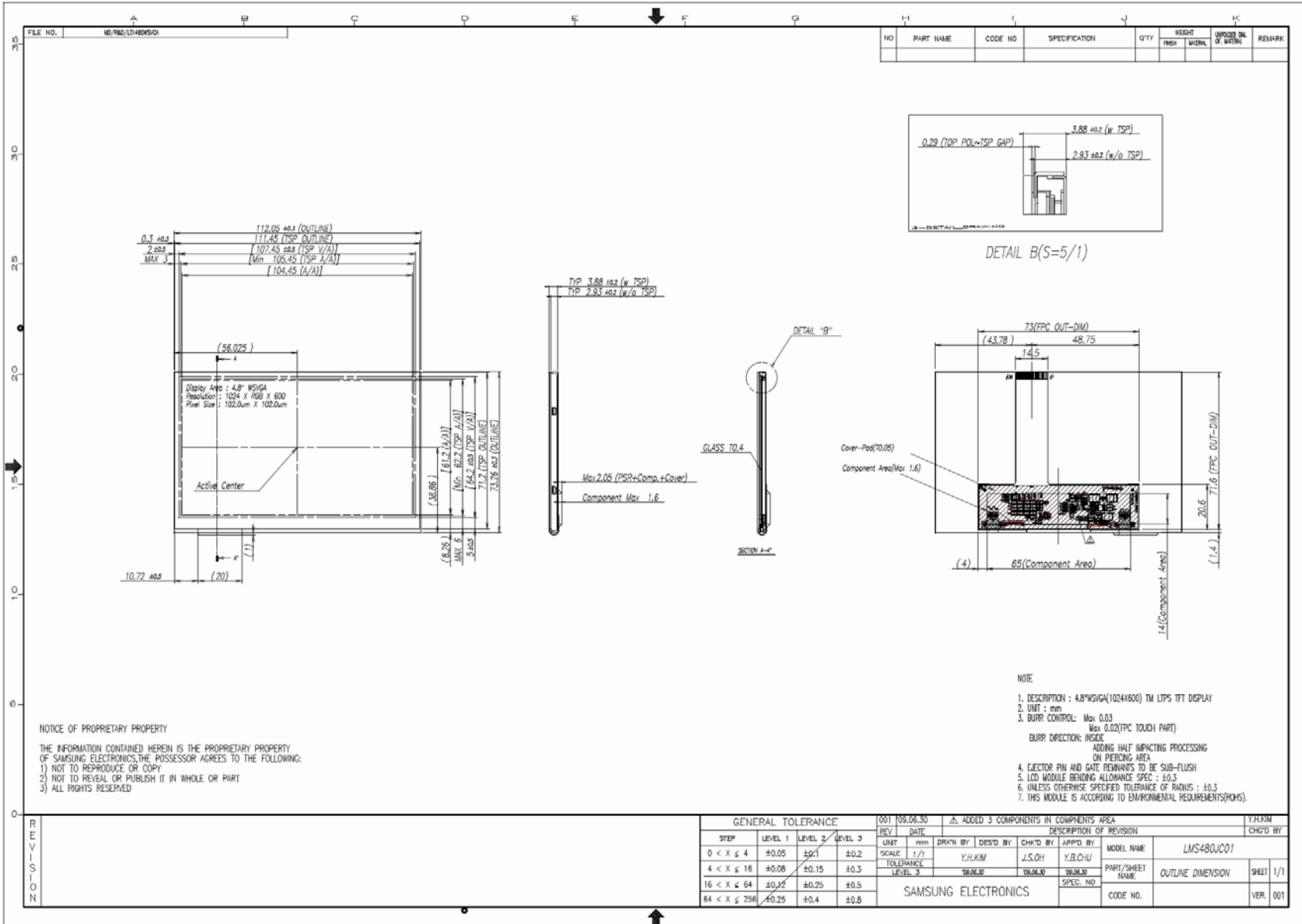

9. PACKING

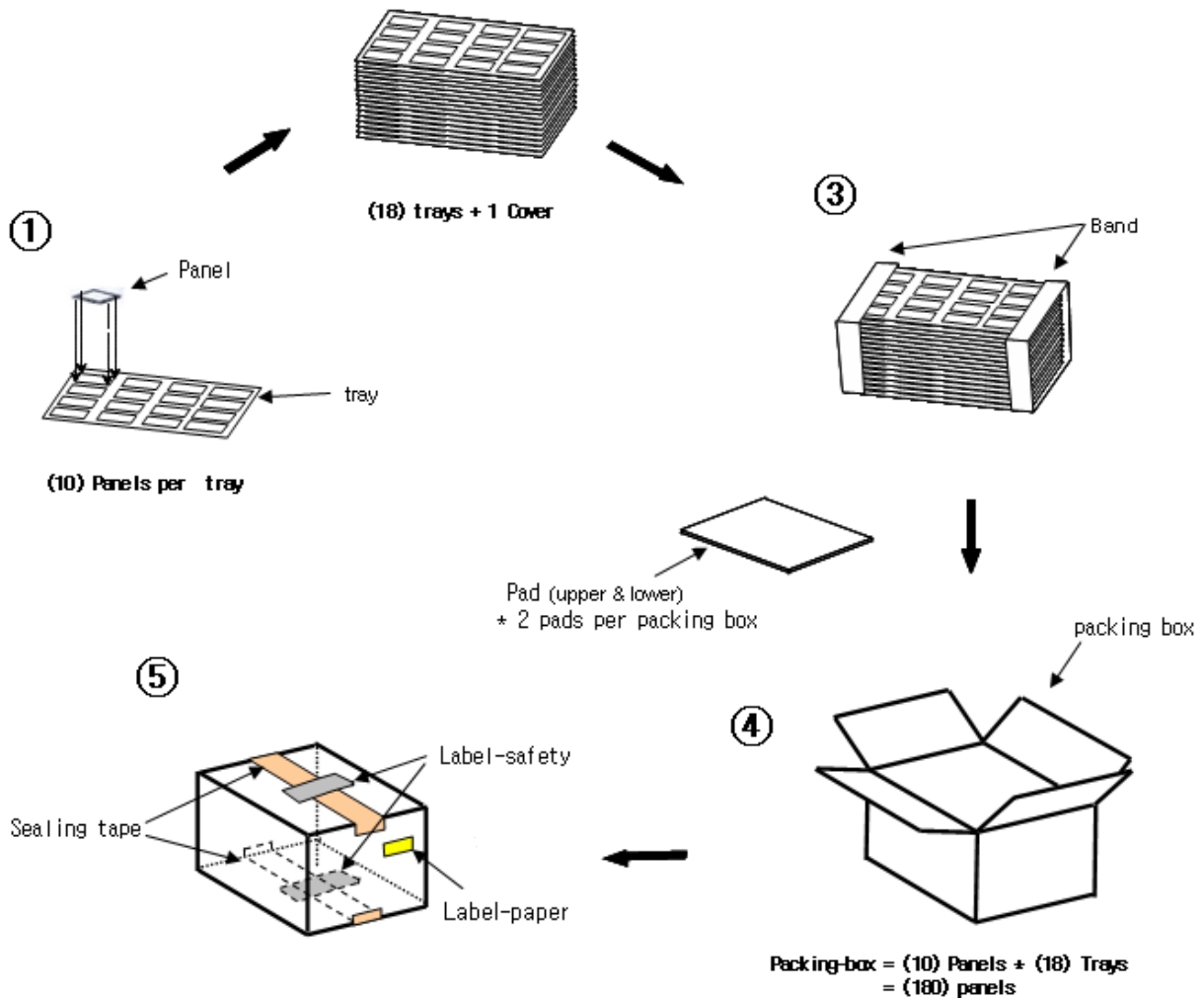

Note (1) Total : Case: Approx. 3.1 Kg

Box: Approx. 15.7Kg

(2) Size : Case: 490(W) x 342(D) x 58(H)

Box: 505(W) x 355(D) x 312(H)

(3) Place the panels in the tray facing the direction shown in the figure.

(4) Place 4 tray and cover(empty tray) and pads inside the packing-case.

(5) Place 5 packing-case inside the packing-box.(Affix the label)

(6) Seal the packing-box. Affix the label-safety.

10. MARKING & OTHERS

A nameplate bearing followed by is affixed to a shipped product at the specified location on each product.

(1) Packing case attach

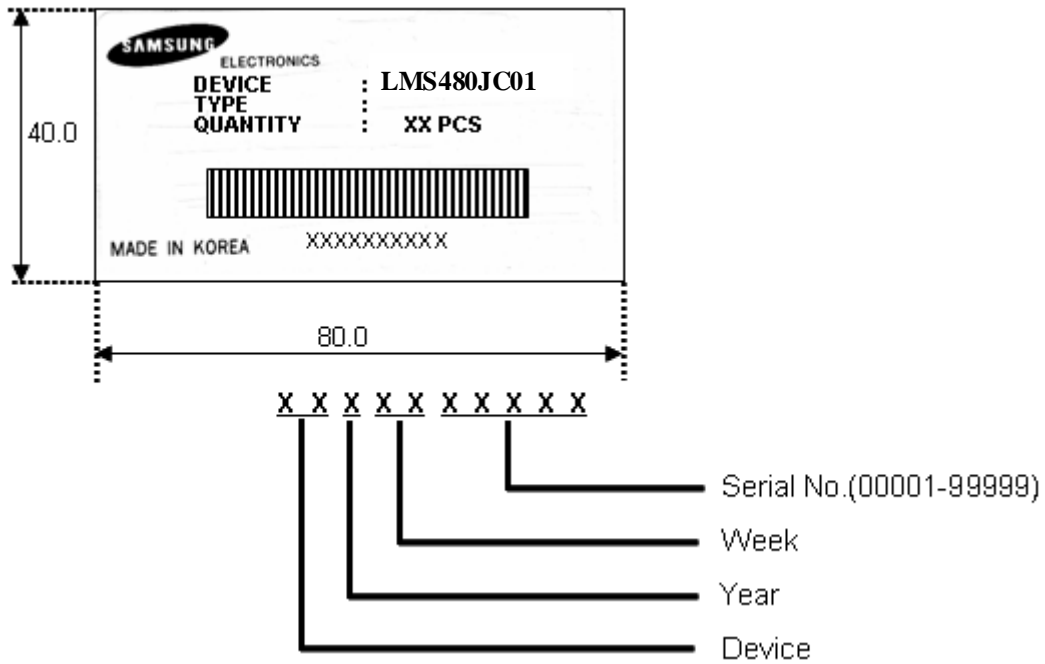

11. General Precautions

11.1 Handling

- (a) When the module is assembled, it should be attached to the system firmly. Be careful not to twist and bend the module.
- (b) Refrain from strong mechanical shock and / or any force to the module. In addition to damage, this may cause improper operation or damage to the module and back-light unit.
- (c) Note that polarizers are very fragile and could be easily damaged. Do not press or scratch the surface harder than a HB pencil lead.
- (d) Wipe off water droplets or oil immediately. If you leave the droplets for a long time, Staining and discoloration may occur.
- (e) If the surface of the polarizer is dirty, clean it using some absorbent cotton or soft cloth.
- (f) The desirable cleaners are water, IPA(Isopropyl Alcohol) or Hexane. Do not use Ketone type materials(ex. Acetone), Ethyl alcohol, Toluene, Ethylacid or Methyl chloride. It might permanent damage to the polarizer due to chemical reaction.
- (g) If the liquid crystal material leaks from the panel, it should be kept away from the eyes or mouth. In case of contact with hands, legs or clothes, it must be washed away thoroughly with soap.
- (h) Protect the module from static, it may cause damage to the CMOS Gate Array IC.
- (i) Use finger-stalls with soft gloves in order to keep display clean during the incoming inspection and assembly process.
- (j) Do not disassemble the module.
- (k) Protection film for polarizer on the module shall be slowly peeled off just before use so that the electrostatic charge can be minimized.
- (l) Pins of I/F connector shall not be touched directly with bare hands.

11.2 Storage

- (a) Do not leave the panel in high temperature, and high humidity for a long time. It is highly recommended to store the module with temperature from 0 to 35°C and relative humidity of less than 70%.
- (b) Do not store the TFT-LCD module in direct sunlight.
- (c) The module shall be stored in a dark place. It is prohibited to apply sunlight or fluorescent light during the store.

11.3 Operation

- (a) Do not connect, disconnect the module in the "Power On" condition.
- (b) Power supply should always be turned on/off by the item 7.3 "Power on/off sequence"

11.4 Others

- (a) The liquid-crystal is deteriorated by ultraviolet rays. Do not leave it in direct sunlight and strong ultraviolet rays for many hours.
- (b) Avoid condensation of water. It may result in improper operation or disconnection of electrode.
- (c) Do not exceed the absolute maximum rating value. (the supply voltage variation, input voltage variation, variation in part contents and environmental temperature, and so on) Otherwise the panel may be damaged.
- (d) If the panel displays the same pattern continuously for a long period of time, it can be the situation when the image "Sticks" to the screen.
- (e) This panel has its circuitry FPC on the bottom side and should be handled carefully in order not to be stressed.