

# MAXIM

## Complete, Isolated, RS-485/RS-422 Data Interface

### General Description

The MAX1480A/MAX1480B/MAX1490A/MAX1490B are complete, electrically isolated, RS-485/RS-422 data-communications interface solutions. Transceivers, optocouplers, and a transformer provide a complete interface in a standard DIP package. A single +5V supply on the logic side powers both sides of the interface.

The MAX1480B/MAX1490B feature reduced-slew-rate drivers that minimize EMI and reduce reflections caused by improperly terminated cables, allowing error-free data transmission at data rates up to 250kbps. The MAX1480A/MAX1490A driver slew rate is not limited, allowing transmission rates up to 2.5Mbps. The MAX1480A/B are designed for half-duplex communication, while the MAX1490A/B feature full-duplex communication.

Drivers are short-circuit current limited and protected against excessive power dissipation by thermal shutdown circuitry that places the driver outputs into a high-impedance state. The receiver input has a fail-safe feature that guarantees a known output (RO low for the MAX1480A/B, RO high for the MAX1490A/B) if the input is open circuit.

The MAX1480A/MAX1480B/MAX1490A/MAX1490B typically withstand 1600VRMS (1 minute) or 2000VRMS (1 second). Their isolated outputs meet all RS-485/RS-422 specifications. The MAX1480A/B are available in a 28-pin DIP package, and the MAX1490A/B are available in a 24-pin DIP package.

### Selection Table

PART	HALF/FULL DUPLEX	DATA RATE (Mbps)	SLEW-RATE LIMITED	DRIVER ENABLE
MAX1480A	Half	2.5	No	Yes
MAX1480B	Half	0.25	Yes	Yes
MAX1490A	Full	2.5	No	No
MAX1490B	Full	0.25	Yes	No

### Applications

Isolated RS-485/RS-422 Data Interface  
Transceivers for EMI-Sensitive Applications  
Industrial-Control Local Area Networks  
Automatic Test Equipment  
HVAC/Building Control Networks

### Features

- ◆ Isolated Data Interface, Typically to 1600VRMS (1 minute)
- ◆ Slew-Rate Limited for Errorless Data Transmission (MAX1480B/MAX1490B)
- ◆ High-Speed, Isolated, 2.5Mbps RS-485/RS-422 Interface (MAX1480A/MAX1490A)
- ◆ Full-Duplex Data Communication (MAX1490A/B)
- ◆ -7V to +12V Common-Mode Input Voltage Range with Respect to Isolated Ground
- ◆ Single +5V Supply
- ◆ Current Limiting and Thermal Shutdown for Driver Overload Protection
- ◆ Standard 0.6" DIP Package:  
28-Pin DIP (MAX1480A/B)  
24-Pin DIP (MAX1490A/B)

### Ordering Information

PART†	TEMP. RANGE	PIN-PACKAGE
MAX1480ACPI	0 °C to +70 °C	28 Wide Plastic DIP
MAX1480AEP1	-40 °C to +85 °C	28 Wide Plastic DIP

Ordering Information continued at end of data sheet.

† Data rate for "A" parts is up to 2500kbps. Data rate for "B" parts is up to 250kbps.

### Pin Configurations

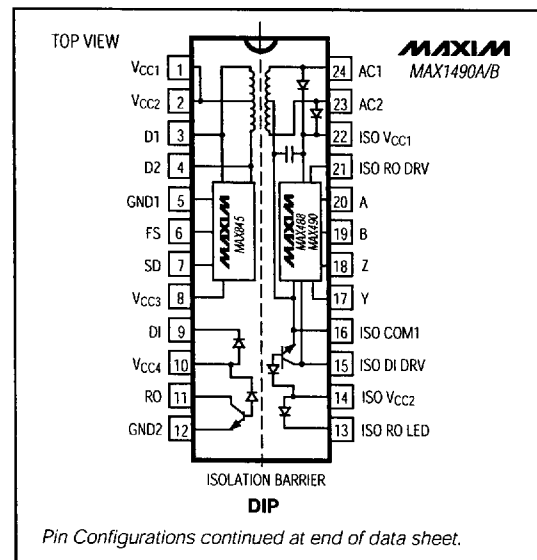

MAXIM

Maxim Integrated Products 1

For free samples & the latest literature: <http://www.maxim-ic.com>, or phone 1-800-998-8800

5876651 0013169 869

MAX1480A/B, MAX1490A/B

# Complete, Isolated, RS-485/RS-422 Data Interface

## ABSOLUTE MAXIMUM RATINGS

With Respect to GND <sub>-</sub>	Supply Voltage (V <sub>CC-</sub> ).....-0.3V to +6V	LED Forward Current (DI, DE, ISO RO LED) .....50mA
Control Input Voltage (SD, FS).....-0.3V to (V <sub>CC-</sub> + 0.3V)	Receiver Output Voltage (RO, RO).....-0.3V to (V <sub>CC-</sub> + 0.3V)	Continuous Power Dissipation (T <sub>A</sub> = +70 °C)
Output Switch Voltage (D1, D2).....+12V	With Respect to ISO COM <sub>-</sub>	24-Pin Plastic DIP (derate 8.7mW/°C above +70 °C) .....696mW
Control Input Voltage (ISO DE <sub>-</sub> ).....-0.3V to (ISO V <sub>CC-</sub> + 0.3V)	Driver Input Voltage (ISO DI <sub>-</sub> ).....-0.3V to (ISO V <sub>CC-</sub> + 0.3V)	28-Pin Plastic DIP (derate 9.09mW/°C above +70 °C) ..727mW
Driver Input Voltage (ISO DI <sub>-</sub> ).....-0.3V to (ISO V <sub>CC-</sub> + 0.3V)	Receiver Output Voltage (ISO RO <sub>-</sub> ).....-0.3V to (ISO V <sub>CC-</sub> + 0.3V)	Operating Temperature Ranges
Receiver Output Voltage (ISO RO <sub>-</sub> ).....-0.3V to (ISO V <sub>CC-</sub> + 0.3V)	Driver Output Voltage (A, B, Y, Z).....-8V to +12.5V	MAX1480_CPI/MAX1490_CPI.....0 °C to +70 °C
Driver Output Voltage (A, B, Y, Z).....-8V to +12.5V	Receiver Input Voltage (A, B).....-8V to +12.5V	MAX1480_EPI/MAX1490_EPI.....-40 °C to +85 °C
		Storage Temperature Range.....-65 °C to +160 °C
		Lead Temperature (soldering, 10sec).....+300 °C

Stresses beyond those listed under "Absolute Maximum Ratings" may cause permanent damage to the device. These are stress ratings only, and functional operation of the device at these or any other conditions beyond those indicated in the operational sections of the specifications is not implied. Exposure to absolute maximum rating conditions for extended periods may affect device reliability.

## ELECTRICAL CHARACTERISTICS

(V<sub>CC-</sub> = 5V ±10%, FS = 0V, T<sub>A</sub> = T<sub>MIN</sub> to T<sub>MAX</sub>, unless otherwise noted. Typical values are at V<sub>CC-</sub> = 5V and T<sub>A</sub> = +25 °C.) (Notes 1, 2)

PARAMETER	SYMBOL	CONDITIONS	MIN	TYP	MAX	UNITS
Supply Voltage	V <sub>S</sub>	FS = 0V	4.5	5.0	5.5	V
		FS = V <sub>CC-</sub> or open	4.75	5.0	5.25	
Switch Frequency	FSWL	FS = 0V	MAX1480A/B	200		kHz
			MAX1490A/B	535		
	FSWH	FS = V <sub>CC-</sub> or open	MAX1480A/B	350		
			MAX1490A/B	725		
Operating Supply Current	I <sub>CC</sub>	MAX1480A, DE <sup>†</sup> = V <sub>CC-</sub> or open	R <sub>L</sub> = ∞	55	90	mA
			R <sub>L</sub> = 54Ω	120		
		MAX1480B, DE <sup>†</sup> = V <sub>CC-</sub> or open	R <sub>L</sub> = ∞	28	45	
			R <sub>L</sub> = 54Ω	86		
		MAX1490A	R <sub>L</sub> = ∞	100	150	
			R <sub>L</sub> = 54Ω	170		
MAX1490B	R <sub>L</sub> = ∞	65	125			
Shutdown Supply Current (Note 3)	ISHDN	SD = V <sub>CC-</sub>	0.2		μA	
Shutdown Input Threshold	V <sub>SDH</sub>	High	2.4		V	
	V <sub>SDL</sub>	Low	0.8			
Shutdown Input Leakage Current			10		pA	
FS Input Threshold	V <sub>FSH</sub>	High	2.4		V	
	V <sub>FSL</sub>	Low	0.8			
FS Input Pull-Up Current		FS low	50		μA	
FS Input Leakage Current		FS high	10		pA	
Input High Voltage	V <sub>IH</sub>	DE <sup>†</sup> , DI <sup>†</sup>	V <sub>CC-</sub> - 0.4		V	
Input Low Voltage	V <sub>IL</sub>	DE <sup>†</sup> , DI <sup>†</sup>	0.4		V	
Isolation Resistance	R <sub>ISO</sub>	T <sub>A</sub> = +25 °C, V <sub>ISO</sub> = 50VDC	100	10,000	MΩ	
Isolation Capacitance	C <sub>ISO</sub>	T <sub>A</sub> = +25 °C, V <sub>ISO</sub> = 50VDC	10		pF	

# Complete, Isolated, RS-485/RS-422 Data Interface

**MAX1480A/B, MAX1490A/B**

## ELECTRICAL CHARACTERISTICS (continued)

( $V_{CC-} = 5V \pm 10\%$ ,  $FS = 0V$ ,  $T_A = T_{MIN}$  to  $T_{MAX}$ , unless otherwise noted. Typical values are at  $V_{CC-} = 5V$  and  $T_A = +25^\circ C$ .)  
(Notes 1, 2)

PARAMETER	SYMBOL	CONDITIONS	MIN	TYP	MAX	UNITS
Differential Driver Output (no load)	$V_{OD1}$				8	V
Differential Driver Output (with load)	$V_{OD2}$	$R = 50\Omega$ (RS-422)	2			V
		$R = 27\Omega$ (RS-485), Figure 4	1.5		5	V
Change in Magnitude of Driver Output Voltage for Complementary Output States	$\Delta V_{OD}$	$R = 27\Omega$ or $50\Omega$ , Figure 4	Differential		0.3	V
			Common Mode		0.3	V
Driver Common-Mode Output	$V_{OC}$	$R = 27\Omega$ or $50\Omega$ , Figure 4			4	V
Input Current (A, B)	ISO $I_{IN}$	$DE' = 0V$ , $V_{CC-} = 0V$ or $5.5V$	$V_{IN} = 12V$		1.0	mA
			$V_{IN} = -7V$		0.8	
Receiver Input Resistance	$R_{IN}$	$-7V \leq V_{CM} \leq 12V$	12			k $\Omega$
Receiver Differential Threshold	$V_{TH}$	$-7V \leq V_{CM} \leq 12V$	-0.2		0.2	V
Receiver Input Hysteresis	$\Delta V_{TH}$	$V_{CM} = 0V$		70		mV
Receiver Output/Receiver Output Low Voltage	$V_{OL}$	Using resistor values listed in Tables 1 and 2			0.4	V
Receiver Output/Receiver Output High Current	$I_{OH}$	$V_{OUT} = 5.5V$			250	$\mu A$
Driver Short-Circuit Current	ISO $I_{OSD}$	$-7V \leq V_O \leq 12V$ (Note 4)		100		mA

## SWITCHING CHARACTERISTICS—MAX1480A/MAX1490A

( $V_{CC-} = 5V \pm 10\%$ ,  $FS = 0V$ ,  $T_A = T_{MIN}$  to  $T_{MAX}$ , unless otherwise noted. Typical values are at  $V_{CC-} = 5V$  and  $T_A = +25^\circ C$ .)

PARAMETER	SYMBOL	CONDITIONS	MIN	TYP	MAX	UNITS
Driver Input to Output Propagation Delay	$t_{PLH}$	Figures 5 and 7, $R_{DIFF} = 54\Omega$ , $C_{L1} = C_{L2} = 100pF$		100	275	ns
	$t_{PHL}$			100	275	
Driver Output Skew	$t_{SKEW}$	Figures 5 and 7, $R_{DIFF} = 54\Omega$ , $C_{L1} = C_{L2} = 100pF$		25	90	ns
Driver Rise or Fall Time	$t_R, t_F$	Figures 5 and 7, $R_{DIFF} = 54\Omega$ , $C_{L1} = C_{L2} = 100pF$		15	40	ns
Driver Enable to Output High (MAX1480A only)	$t_{ZH}$	Figures 6 and 8, $C_L = 100pF$ , S2 closed		0.5	1.5	$\mu s$
Driver Enable to Output Low (MAX1480A only)	$t_{ZL}$	Figures 6 and 8, $C_L = 100pF$ , S1 closed		0.5	1.5	$\mu s$
Driver Disable Time from Low (MAX1480A only)	$t_{LZ}$	Figures 6 and 8, $C_L = 15pF$ , S1 closed		0.5	1.5	$\mu s$
Driver Disable Time from High (MAX1480A only)	$t_{HZ}$	Figures 6 and 8, $C_L = 15pF$ , S2 closed		0.5	1.5	$\mu s$
Receiver Input to Output Propagation Delay	$t_{PLH}$	Figures 5 and 10, $R_{DIFF} = 54\Omega$ , $C_{L1} = C_{L2} = 100pF$		100	225	ns
	$t_{PHL}$			100	225	
$t_{PLH} - t_{PHL}$   Differential Receiver Skew	$t_{SKD}$	Figures 5 and 10, $R_{DIFF} = 54\Omega$ , $C_{L1} = C_{L2} = 100pF$		20		ns
Maximum Data Rate	$f_{MAX}$	$t_{PLH}, t_{PHL} < 50\%$ of data period	2.5			Mbps
Time to Shutdown	$t_{SHDN}$			100		$\mu s$
Shutdown to Driver Output High	$t_{ZH}(SHDN)$	Figures 6 and 9, $C_L = 100pF$ , S2 closed		3	10	$\mu s$
Shutdown to Driver Output Low	$t_{ZL}(SHDN)$	Figures 6 and 9, $C_L = 100pF$ , S1 closed		3	10	$\mu s$

# Complete, Isolated, RS-485/RS-422 Data Interface

MAX1480A/B, MAX1490A/B

## SWITCHING CHARACTERISTICS—MAX1480B/MAX1490B

(VCC\_ = 5V ± 10%, FS = 0V, TA = TMIN to TMAX, unless otherwise noted. Typical values are at VCC\_ = 5V and TA = +25 °C.)

PARAMETER	SYMBOL	CONDITIONS	MIN	TYP	MAX	UNITS
Driver Input to Output Propagation Delay	tPLH	Figures 5 and 7, RDIFF = 54Ω, CL1 = CL2 = 100pF		1.0	2.0	μs
	tPHL	Figures 5 and 7, RDIFF = 54Ω, CL1 = CL2 = 100pF		1.0	2.0	
Driver Output Skew	tsKEW	Figures 5 and 7, RDIFF = 54Ω, CL1 = CL2 = 100pF		100	800	ns
Driver Rise or Fall Time	tR, tF	Figures 5 and 7, RDIFF = 54Ω, CL1 = CL2 = 100pF		1.0	2.0	μs
Driver Enable to Output High (MAX1480B only)	tZH	Figures 6 and 8, CL = 100pF, S2 closed		35	100	μs
Driver Enable to Output Low (MAX1480B only)	tZL	Figures 6 and 8, CL = 100pF, S1 closed		35	100	μs
Driver Disable Time from Low (MAX1480B only)	tLZ	Figures 6 and 8, CL = 15pF, S1 closed		13	50	μs
Driver Disable Time from High (MAX1480B only)	tHZ	Figures 6 and 8, CL = 15pF, S2 closed		13	50	μs
Receiver Input to Output Propagation Delay	tPLH	Figures 5 and 10, RDIFF = 54Ω, CL1 = CL2 = 100pF		0.8	2.0	μs
	tPHL			0.8	2.0	
tPLH - tPHL  Differential Receiver Skew	tsKD	Figures 5 and 10, RDIFF = 54Ω, CL1 = CL2 = 100pF		200		ns
Maximum Data Rate	fMAX	tPLH, tPHL < 50% of data period	0.25			Mbps
Time to Shutdown	tSHDN			100		μs
Shutdown to Driver Output High	tZH(SHDN)	Figures 6 and 9, CL = 100pF, S2 closed		35	100	μs
Shutdown to Driver Output Low	tZL(SHDN)	Figures 6 and 9, CL = 100pF, S1 closed		35	100	μs

**Note 1:** All currents into device pins are positive; all currents out of device pins are negative. All voltages are referenced to logic-side ground (GND\_), unless otherwise specified.

**Note 2:** For DE and DI pin descriptions, see *Detailed Block Diagram and Typical Application Circuit* (Figure 1 for MAX1480A/MAX1480B, Figure 2 for MAX1490A/MAX1490B).

**Note 3:** Shutdown supply current is the current at VCC1 and VCC2 when shutdown is enabled.

**Note 4:** Applies to peak current (see *Typical Operating Characteristics*). Although the MAX1480A/B and MAX1490A/B provide electrical isolation between logic ground and signal paths, they do not provide isolation between external shields and the signal paths (see *Isolated Common Connection* section).

# Complete, Isolated, RS-485/RS-422 Data Interface

## Typical Operating Characteristics

( $V_{CC-} = 5V$ ,  $T_A = +25^\circ C$ , unless otherwise noted.)

**MAX1480A/B, MAX1490A/B**

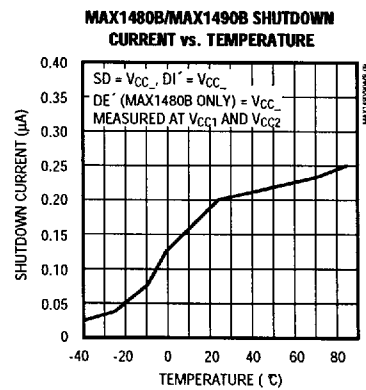
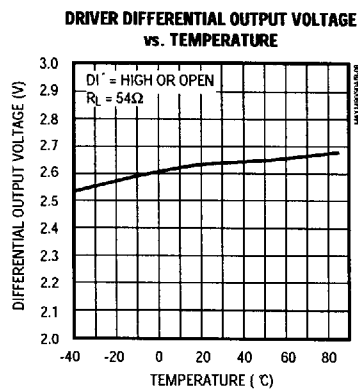
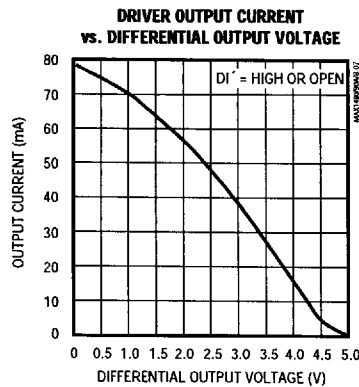
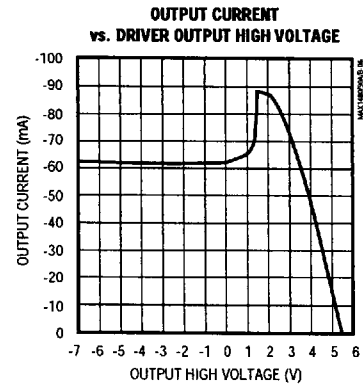
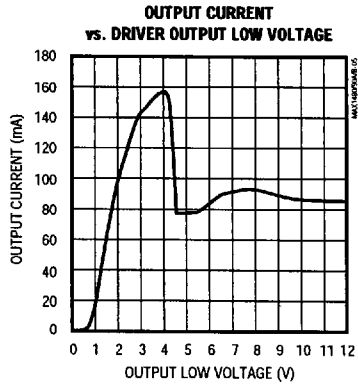
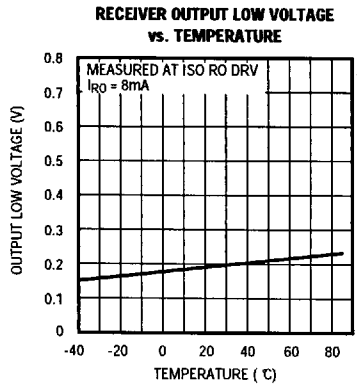
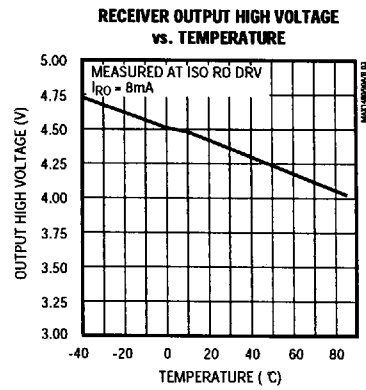
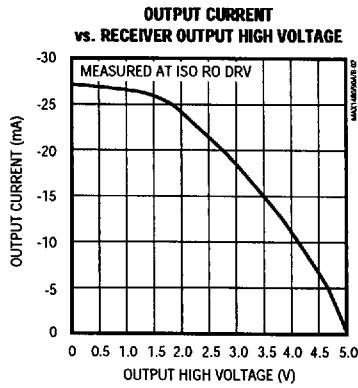
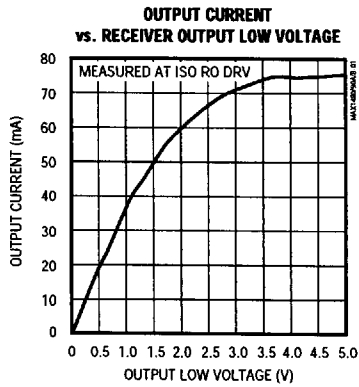

# Complete, Isolated, RS-485/RS-422 Data Interface

## Typical Operating Characteristics (continued)

( $V_{CC-} = 5V$ ,  $T_A = +25^\circ C$ , unless otherwise noted.)

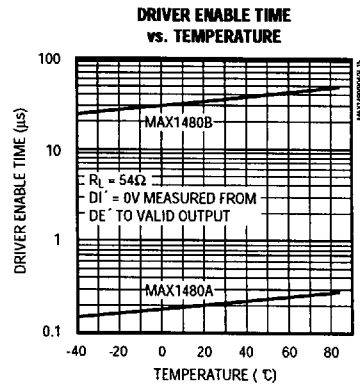
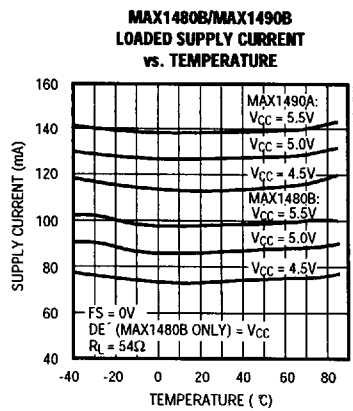
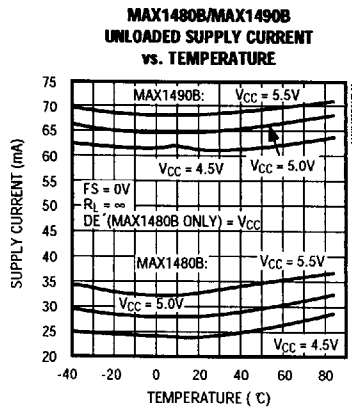
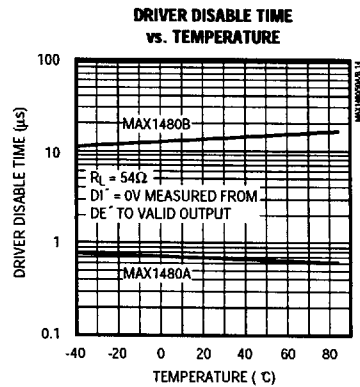
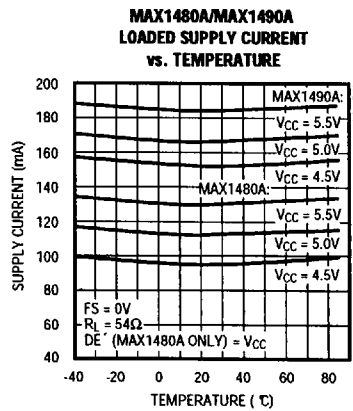
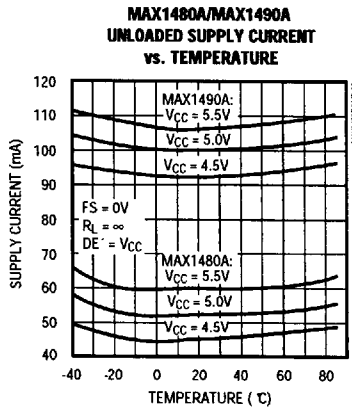

# Complete, Isolated, RS-485/RS-422 Data Interface

## Typical Operating Characteristics (continued)

( $V_{CC} = 5V$ ,  $T_A = +25^\circ C$ , unless otherwise noted.)

**MAX1480A/B, MAX1490A/B**

**MAX1480A/MAX1490A  
POWER-UP DELAY TO DRIVER OUTPUTS VALID**

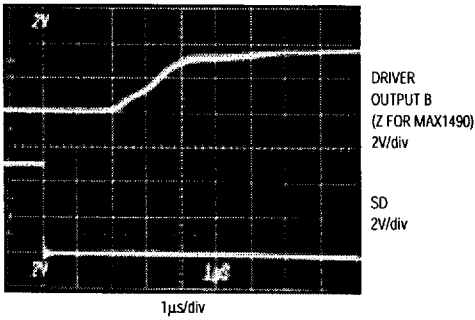

$V_{CC} = 5.0V$ ,  $DI = 0V$   
SD = 5V TO 0V AT 1kHz

**MAX1480B  
DRIVER ENABLE TIME**

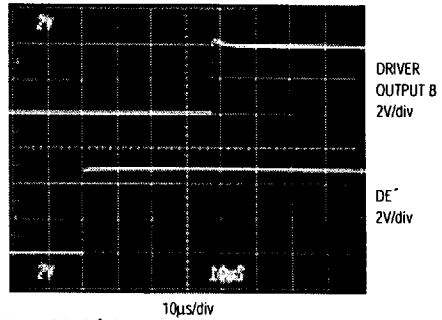

$V_{CC} = 5.0V$ ,  $DI = 0V$   
DE- TOGGLED 0V TO 5V AT 5kHz

**MAX1480B  
DRIVER DISABLE TIME**

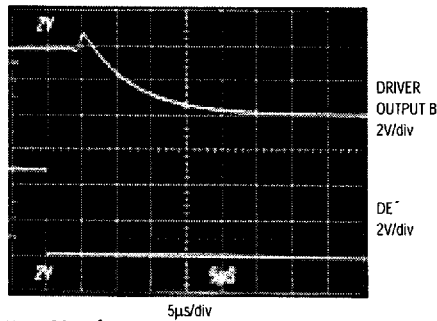

$V_{CC} = 5.0V$ ,  $DI = 0V$   
DE- TOGGLED 0V TO 5V AT 5kHz

**MAX1480A  
DRIVER ENABLE TIME**

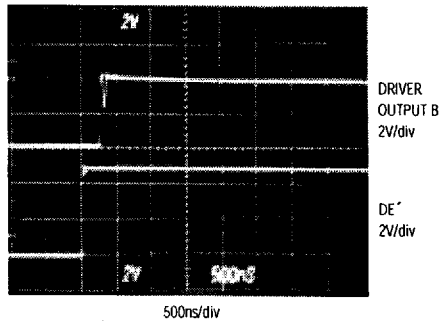

$V_{CC} = 5.0V$ ,  $DI = 0V$   
DE- TOGGLED 0V TO 5V AT 5kHz

**MAX1480A  
DRIVER DISABLE TIME**

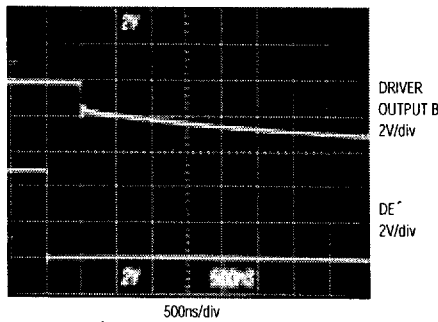

$V_{CC} = 5.0V$ ,  $DI = 0V$   
DE- TOGGLED 0V TO 5V AT 5kHz

# Complete, Isolated, RS-485/RS-422 Data Interface

## Typical Operating Characteristics (continued)

( $V_{CC-} = 5V$ ,  $T_A = +25^\circ C$ , unless otherwise noted.)

**MAX1480A/MAX1490A**  
RECEIVER  $t_{PHL}$

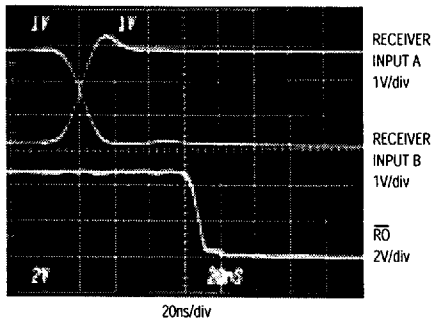

$V_{CC-} = 5.0V$ ,  $DE^- = V_{CC-}$   
 $DI^- = 0V$  TO  $5V$  AT  $1.25MHz$

**MAX1480A/MAX1490A**  
RECEIVER  $t_{PLH}$

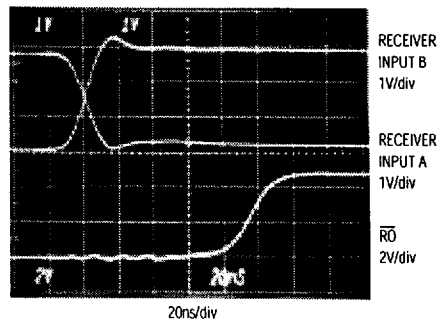

$V_{CC-} = 5.0V$ ,  $DE^- = V_{CC-}$   
 $DI^- = 0V$  TO  $5V$  AT  $1.25MHz$

**MAX1480B/MAX1490B**  
RECEIVER  $t_{PHL}$

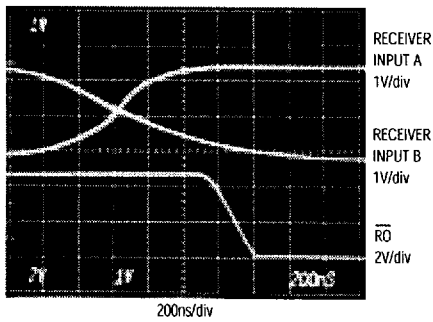

$V_{CC-} = 5.0V$ ,  $DE^- = V_{CC-}$   
 $DI^- = 0V$  TO  $5V$  AT  $125kHz$

**MAX1480B/MAX1490B**  
RECEIVER  $t_{PLH}$

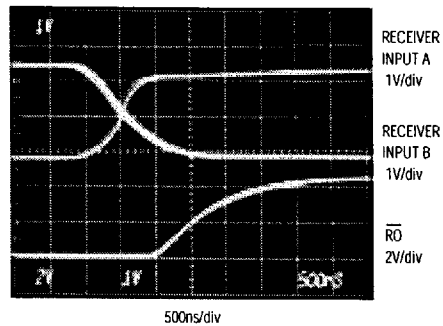

$V_{CC-} = 5.0V$ ,  $DE^- = V_{CC-}$   
 $DI^- = 0V$  TO  $5V$  AT  $125kHz$



# Complete, Isolated, RS-485/RS-422 Data Interface

## Pin Descriptions

**MAX1480A/B, MAX1490A/B**

PIN		NAME	FUNCTION
MAX1480A/B	MAX1490A/B		
<b>PINS ON THE NON-ISOLATED SIDE</b>			
1, 2, 8, 10	1, 2, 8, 10	VCC1-VCC4	Logic-Side (non-isolated side) +5V Supply Voltages
3, 4	3, 4	D1, D2	Internal Connections. Leave these pins unconnected.
5	5	GND1	Logic-Side Ground. Connect to GND2 (pin 12).
6	6	FS	Frequency Switch Input. If FS = Vcc_ or is open, switch frequency is high; if FS = 0V, switch frequency is low.
7	7	SD	Shutdown Input. Ground for normal operation. When high, the power oscillator is disabled.
9	9	DI	Driver Input. With DE <sup>+</sup> high (MAX1480A/B only), a low on DI <sup>+</sup> forces output A low and output B high. Similarly, a high on DI <sup>+</sup> forces output A high and output B low. Drives internal LED cathode through a resistor (Table 1 of Figure 1 for MAX1480, Table 2 of Figure 2 for MAX1490).
11	—	DE	Driver-Enable Input. The driver outputs, A and B, are enabled by bringing DE <sup>+</sup> high. The driver outputs are high impedance when DE <sup>+</sup> is low. If the driver outputs are enabled, the device functions as a line driver. While the driver outputs are high impedance, the device functions as a line receiver. Drives internal LED cathode through a resistor (Table 1 of Figure 1).
—	11	RO	Receiver Output. If A > B by 200mV, RO will be high; if A < B by 200mV, RO will be low. Open collector; must have pull-up to Vcc (Table 2 of Figure 2).
12	12	GND2	Logic-Side Ground. Connect to GND1 (pin 5).
13	—	RO	Receiver Output. If A > B by 200mV, RO will be low; if A < B by 200mV, RO will be high. Open collector; must have pull-up to Vcc_ (Table 1 of Figure 1).
14	—	VCC5	Logic-Side (non-isolated side) +5V Supply Voltage
<b>PINS ON THE ISOLATED RS-485/RS-422 SIDE</b>			
15	13	ISO RO LED	Isolated Receiver Output LED. Internal LED anode in MAX1480 and LED cathode in MAX1490. Connect to ISO RO DRV through a resistor (Table 1 of Figure 1 for MAX1480; Table 2 of Figure 2 for MAX1490).
16	—	ISO COM2	Isolated Common. Connect to ISO COM1 (pin 20).
17	—	ISO DE DRV	Isolated Driver-Enable Drive. The driver outputs, A and B, are enabled by bringing DE <sup>+</sup> high. The driver outputs are high impedance when DE <sup>+</sup> is low. If the driver outputs are enabled, the device functions as a line driver. While the driver outputs are high impedance, the device functions as a line receiver. Open-collector output; must have pull-up to ISO VCC_ and be tied to ISO DE IN for normal operation (Table 1 of Figure 1).
18	14	ISO VCC2	Isolated Supply Voltage. Connect to ISO VCC1 (pin 26 for MAX1480, or pin 22 for MAX1490).
19	15	ISO DI DRV	Isolated Driver-Input Drive. With DE <sup>+</sup> high (MAX1480 only), a low on DI <sup>+</sup> forces output A low and output B high. Similarly, a high on DI <sup>+</sup> forces output A high and output B low. Connect to ISO DI IN (on the MAX1480 only) for normal operation. Open-collector output; connect a pull-up resistor to ISO Vcc_ (Table 1 of Figure 1 for MAX1480; Table 2 of Figure 2 for MAX1490).
20	16	ISO COM1	Isolated Common. For MAX1480, connect to ISO COM2 (pin 16) (Figures 1 and 2).

# Complete, Isolated, RS-485/RS-422 Data Interface

MAX1480A/B, MAX1490A/B

## Pin Descriptions (continued)

PIN		NAME	FUNCTION
MAX1480A/B	MAX1490A/B		
<b>PINS ON THE ISOLATED RS-485/RS-422 SIDE (continued)</b>			
—	17	Y	Noninverting Driver Output
—	18	Z	Inverting Driver Output
—	19	B	Inverting Receiver Input
—	20	A	Noninverting Receiver Input
21	—	ISO DE IN	Isolated Driver-Enable Input. Connect to ISO DI DRV for normal operation.
22	—	ISO DI IN	Isolated Driver Input. Connect to ISO DI DRV for normal operation.
23	—	A	Noninverting Driver Output and Noninverting Receiver Input
24	21	ISO RO DRV	Isolated Receiver-Output Drive. Connect to ISO RO LED through a resistor (Table 1 of Figure 1 for MAX1480, Table 2 of Figure 2 for MAX1490).
25	—	B	Inverting Driver Output and Inverting Receiver Input
26	22	ISO V <sub>CC1</sub>	Isolated Supply Voltage Source
27, 28	23, 24	AC2, AC1	Internal Connections. Leave these pins unconnected.

**Note:** For DE<sup>+</sup> and DI<sup>+</sup> pin descriptions, see *Detailed Block Diagram and Typical Application Circuit* (Figure 1 for MAX1480A/B, Figure 2 for MAX1490A/B).

### Detailed Description

The MAX1480A/MAX1480B/MAX1490A/MAX1490B are complete, electrically isolated, RS-485/RS-422 data-communications interface solutions. Transceivers, optocouplers, a power driver, and a transformer in one standard 28-pin DIP package (24-pin for the MAX1490A/B) provide a complete interface. Signals and power are internally transported across the isolation barrier (Figures 1, 2). Power is transferred from the logic side (non-isolated side) to the isolated side of the barrier through a center-tapped transformer. Signals cross the barrier through high-speed optocouplers. A single +5V supply on the logic side powers both sides of the interface. The MAX1480A/B offer half-duplex communications while the MAX1490A/B feature full-duplex communication. The functional input/output relationships are shown in Tables 3–6.

The MAX1480B/MAX1490B feature reduced-slew-rate drivers that minimize EMI and reduce reflections caused by improperly terminated cables, allowing error-free transmission at data rates up to 250kbps. The MAX1480A/MAX1490A driver slew rate is not limited, allowing transmission rates up to 2.5Mbps.

The MAX1480B/MAX1490B shutdown feature reduces supply current to as low as 0.2 $\mu$ A by using the SD pin (see *Low-Power Shutdown Mode* section).

Use the FS pin to select between high and low switching frequencies for the isolated power driver. The driver switches at the lower frequency (200kHz for the MAX1480A/B, 535kHz for the MAX1490A/B) when FS is low, and at the higher frequency (350kHz for the MAX1480A/B, 725kHz for the MAX1490A/B) when FS is high. At the lower switching frequency, the devices' operating voltage ranges increase from 5V  $\pm$ 5% to 5V  $\pm$ 10%.

The FS pin has a weak internal pull-up that switches the device to the high-frequency mode when FS is left unconnected. With FS high or open, no-load supply current is reduced by approximately 4mA, and by up to 8mA when fully loaded.

Drivers are short-circuit current limited and are protected against excessive power dissipation by thermal shutdown circuitry that puts the driver outputs into a high-impedance state. The receiver input has a fail-safe feature that guarantees a logic-high RO (logic-low  $\overline{RO}$ ) output if the input is open circuit.

On the MAX1480A/B, the driver outputs are enabled by bringing DE<sup>+</sup> high. Driver-enable times are typically 0.5 $\mu$ s for the MAX1480A and 35 $\mu$ s for the MAX1480B. Allow time for the devices to be enabled before sending data (see the Driver Enable Time vs. Temperature graph in the *Typical Operating Characteristics*). When enabled, driver outputs function as line drivers. Driver outputs are high impedance when DE<sup>+</sup> is low. While outputs are high impedance, they function as line receivers.

# Complete, Isolated, RS-485/RS-422 Data Interface

**MAX1480A/B, MAX1490A/B**

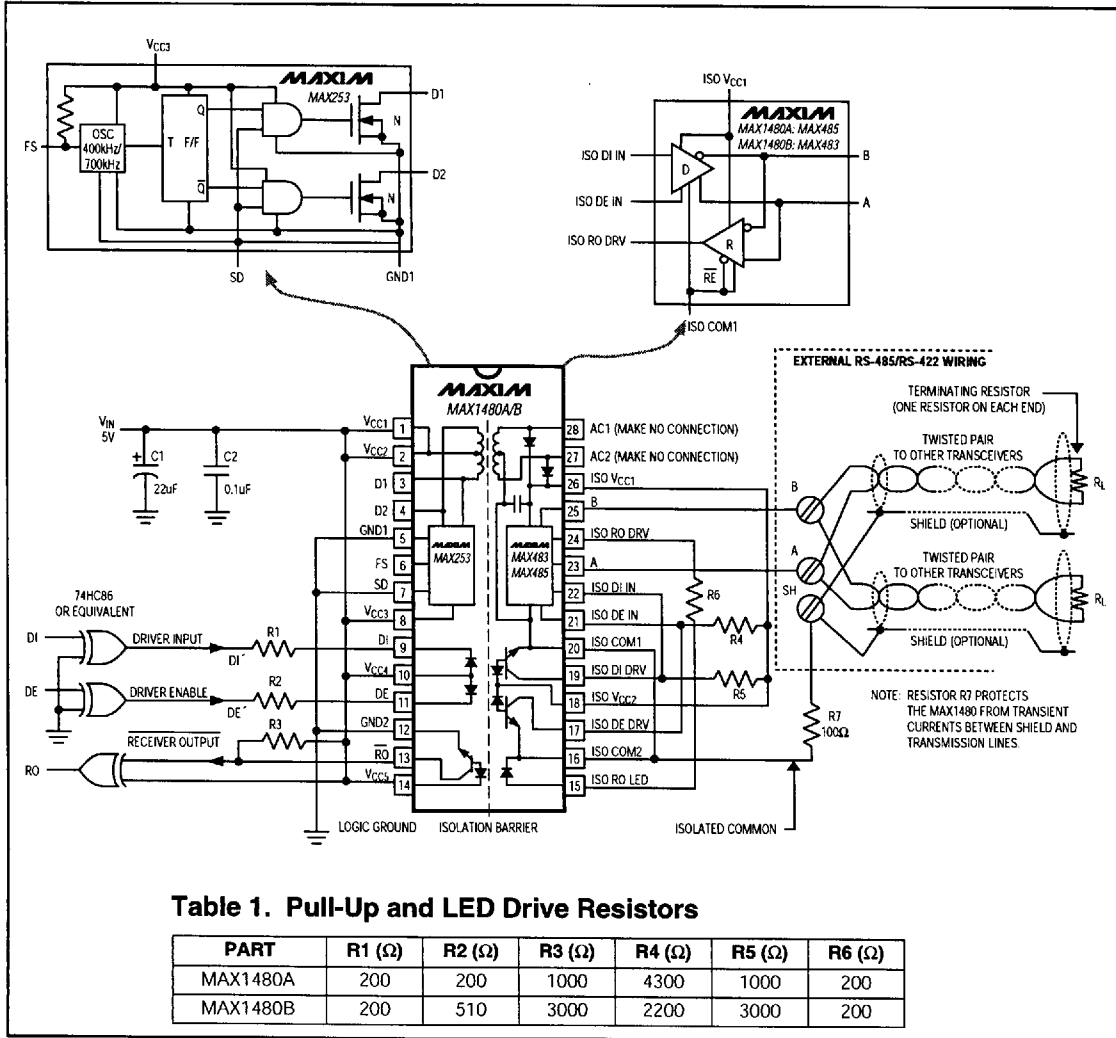

**Table 1. Pull-Up and LED Drive Resistors**

PART	R1 (Ω)	R2 (Ω)	R3 (Ω)	R4 (Ω)	R5 (Ω)	R6 (Ω)
MAX1480A	200	200	1000	4300	1000	200
MAX1480B	200	510	3000	2200	3000	200

Figure 1. MAX1480A/MAX1480B Detailed Block Diagram and Typical Application Circuit

The MAX1480A/MAX1480B/MAX1490A/MAX1490B typically withstand 1600VRMS (1 minute) or 2000VRMS (1 second). The logic inputs can be driven from TTL/CMOS-logic with a series resistor, and the received data output can directly drive TTL or CMOS-logic families with only resistive pull-up.

### Low-Power Shutdown Mode

The SD pin shuts down the oscillator on the internal power driver. With the primary side in shutdown, no power is transferred across the isolation barrier. The DI and DE optocouplers, however, still consume current if the drive signals on the non-isolated side are low. Therefore, leave DI<sup>-</sup> and DE<sup>-</sup> high or floating when in shutdown mode.

# Complete, Isolated, RS-485/RS-422 Data Interface

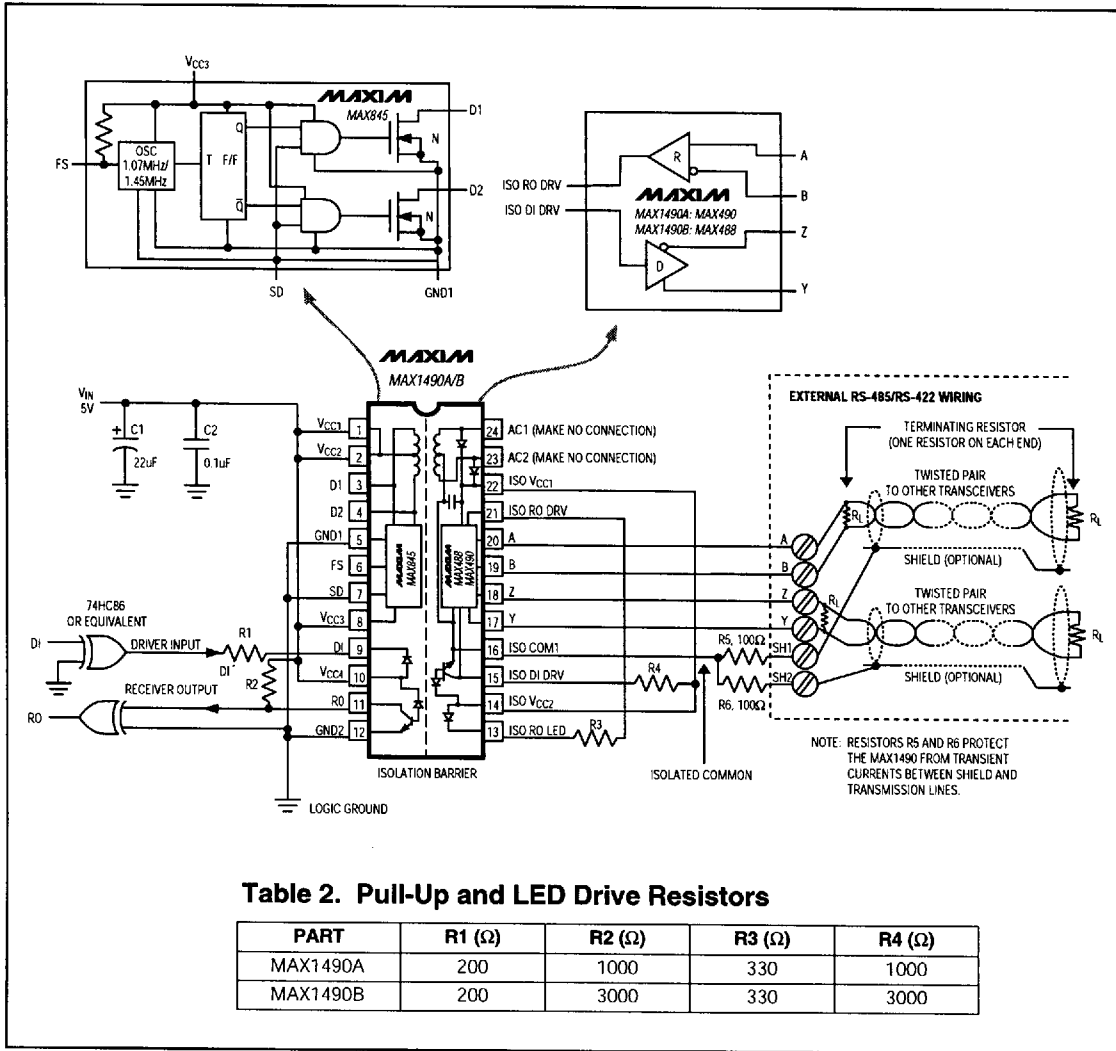

Figure 2. MAX1490A/MAX1490B Detailed Block Diagram and Typical Application Circuit

Under these conditions, the MAX1480B/MAX1490B supply current is reduced to as low as 0.2 $\mu$ A.

The high-speed optocouplers on the MAX1480A/MAX1490A consume an additional 10mA through VCC5 (VCC4 for the MAX1490A). Therefore, to completely shut down these devices, use an external P-channel MOSFET as shown in Figure 3. In normal operation, SD is low, turning

the MOSFET on and thereby providing power to all the VCC<sub>n</sub> pins. When SD is pulled high, the power oscillator is disabled and the switch is turned off, disconnecting power from the DI and DE optocouplers. In normal operating mode, the switch carries only the optocoupler currents, so an on-resistance of several ohms will not significantly degrade efficiency.

# Complete, Isolated, RS-485/RS-422 Data Interface

**MAX1480A/B, MAX1490A/B**

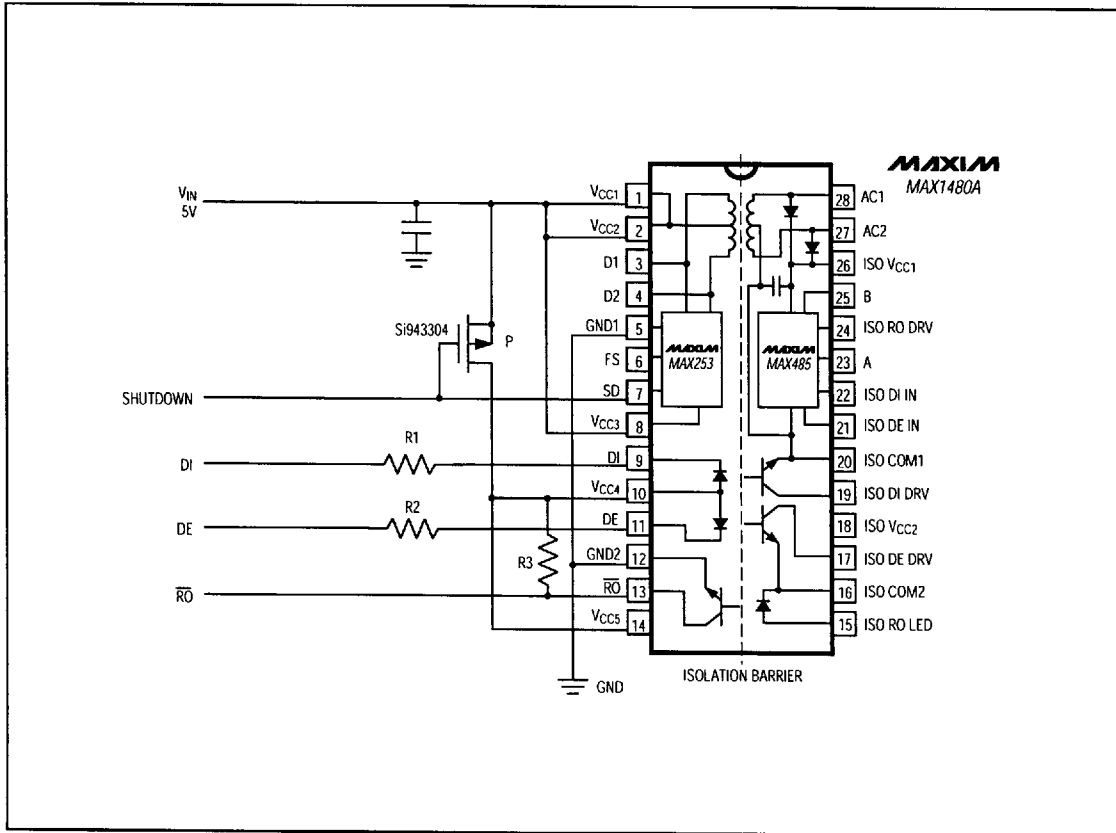

Figure 3. MAX1480A Low-Power Shutdown Mode

## Test Circuits

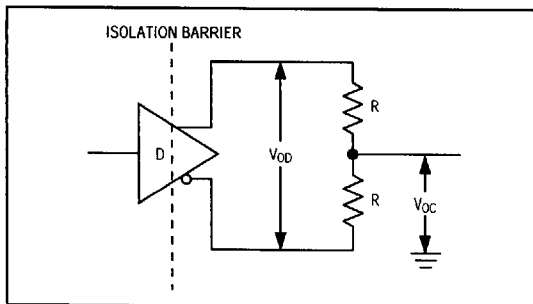

Figure 4. Driver DC Test Load

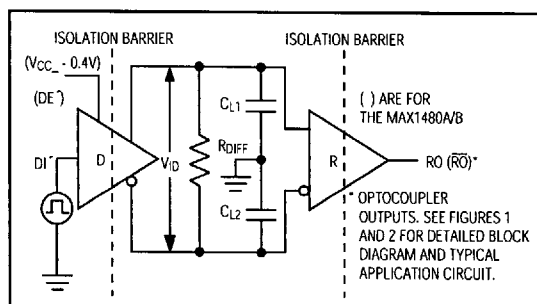

Figure 5. Driver/Receiver Timing Test Circuit

**MAXIM**

# Complete, Isolated, RS-485/RS-422 Data Interface

## Test Circuits (continued)

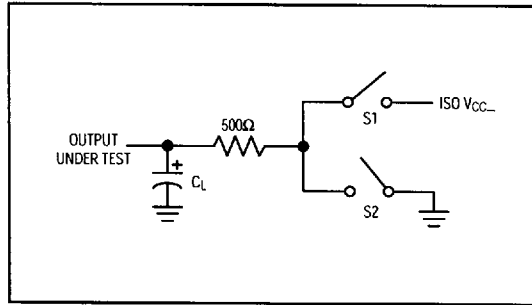

Figure 6. Driver Timing Test Load

## Switching Waveforms

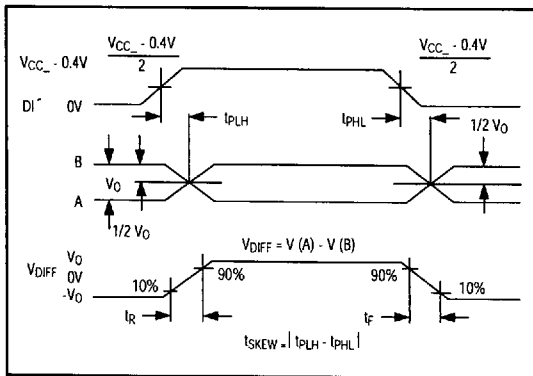

Figure 7. Driver Propagation Delays and Transition Times

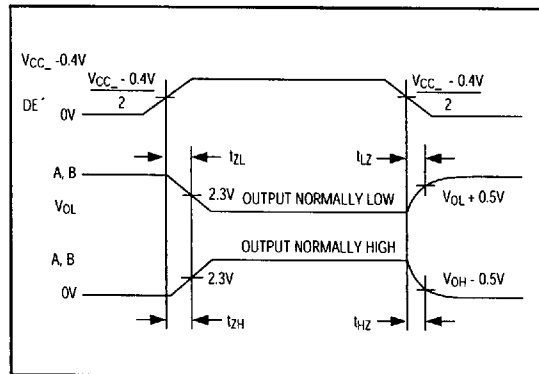

Figure 8. Driver Enable and Disable Times

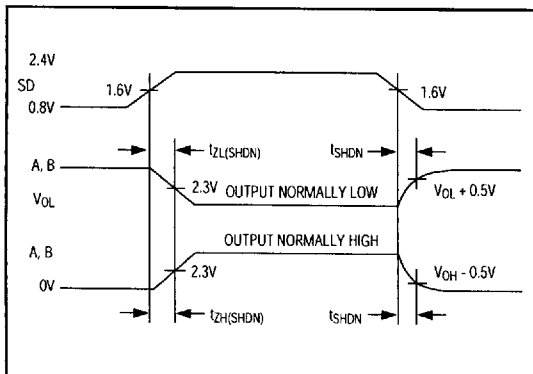

Figure 9. Times to/from Shutdown

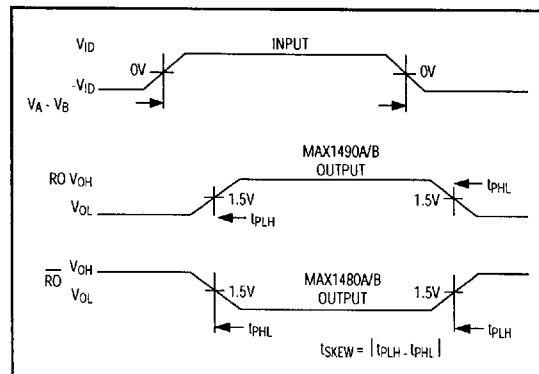

Figure 10. Receiver Propagation Delays

# Complete, Isolated, RS-485/RS-422 Data Interface

MAX1480A/B, MAX1490A/B

## MAX1480B/MAX1490B: Reduced EMI and Reflections

The MAX1480B/MAX1490B are slow-rate-limited, minimizing EMI and reducing reflections caused by improperly terminated cables. Figure 11 shows both the driver output waveform of a MAX1480A/MAX1490A transmitting a 150kHz signal and the Fourier analysis of that waveform. High-frequency harmonics with large amplitudes are evident. Figure 12 shows the same information for the slow-rate-limited MAX1480B/MAX1490B transmitting the same signal. The high-frequency harmonics have much lower amplitudes, and therefore the potential for EMI is significantly reduced.

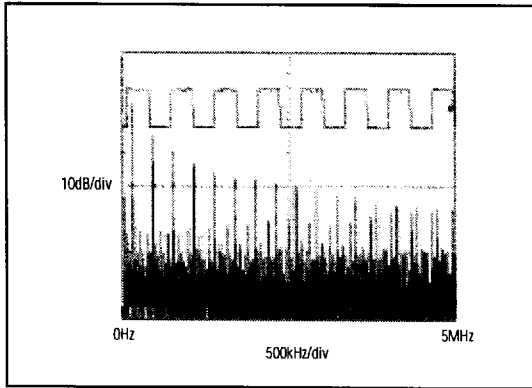

Figure 11. Driver Output Waveform and FFT Plot of MAX1480A/MAX1490A Transmitting a 150kHz Signal

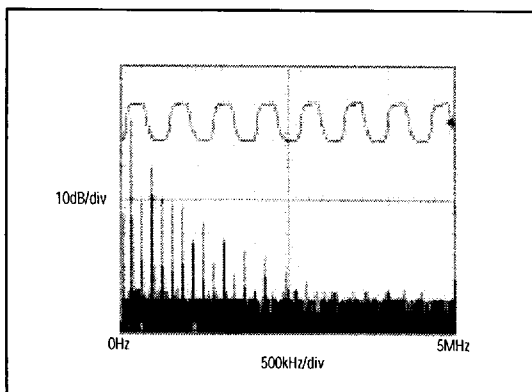

Figure 12. Driver Output Waveform and FFT Plot of MAX1480B/MAX1490B Transmitting a 150kHz Signal

## Function Tables

### Half-Duplex Devices (MAX1480A/MAX1480B)

Table 3. Transmitting

INPUTS*		OUTPUTS	
DE <sup>1</sup>	DI <sup>1</sup>	B	A
1	1	0	1
1	0	1	0
0	X	High-Z	High-Z

X = Don't care  
High-Z = High impedance

Table 4. Receiving

INPUTS*		OUTPUT (RO)
DE <sup>1</sup>	V <sub>A</sub> - V <sub>B</sub>	
0	≥ +0.2V	0
0	≤ -0.2V	1
0	Open	0

### Full-Duplex Devices (MAX1490A/MAX1490B)

Table 5. Transmitting

INPUT (DI <sup>1</sup> )*	OUTPUTS	
	Z	Y
1	0	1
0	1	0

Table 6. Receiving

INPUT* (V <sub>A</sub> - V <sub>B</sub> )	OUTPUT (RO)
≥ +0.2V	1
≤ -0.2V	0
Open	1

\* For DE<sup>1</sup> and DI<sup>1</sup> pin descriptions, see *Detailed Block Diagram and Typical Application Circuit* (Figure 1 for MAX1480A/B, Figure 2 for MAX1490A/B).





# Complete, Isolated, RS-485/RS-422 Data Interface

**MAX1480A/B, MAX1490A/B**

## Driver Output Protection

There are two mechanisms to prevent excessive output current and power dissipation caused by faults or by bus contention. A foldback current limit on the output stage provides immediate protection against short circuits over the entire common-mode range (see *Typical Operating Characteristics*). In addition, a thermal shut-down circuit forces the driver outputs into a high-impedance state if the die temperature rises excessively.

## Propagation Delay Skew

Typical propagation delays are shown in the *Typical Operating Characteristics* using the test circuit of Figure 5. Propagation delay skew is simply the difference between the low-to-high and high-to-low propagation delay. Small driver/receiver skew times help reduce EMI and reflections by maintaining balanced differential signals.

The receiver skew time,  $|t_{PLH} - t_{PHL}|$ , is typically under 100ns for the MAX1480A/MAX1490A and under 1 $\mu$ s for the MAX1480B/MAX1490B.

The driver skew time is typically 25ns for the MAX1480A/MAX1490A and 100ns for the MAX1480B/MAX1490B.

## Applications Information

**DI and DE are intended to be driven through a series current-limiting resistor. Directly grounding these pins destroys the device.**

The MAX1480A/MAX1480B are designed for bidirectional data communications on multipoint bus-transmission lines. The MAX1490A/MAX1490B are designed for full-duplex bidirectional communications that are primarily point-to-point. Figures 13 and 14 show half-duplex and full-duplex typical network application circuits, respectively. To minimize reflections, terminate the line at both ends with its characteristic impedance, and keep stub lengths off the main line as short as possible. The slew-rate-limited MAX1480B/MAX1490B are more tolerant of imperfect termination and stubs off the main line.

## Layout Considerations

The MAX1480A/MAX1480B/MAX1490A/MAX1490B pinouts enable optimal PC board layout by minimizing interconnect lengths and crossovers.

- For maximum isolation, the "isolation barrier" should not be breached except by the MAX1480A/MAX1480B/MAX1490A/MAX1490B. Connections

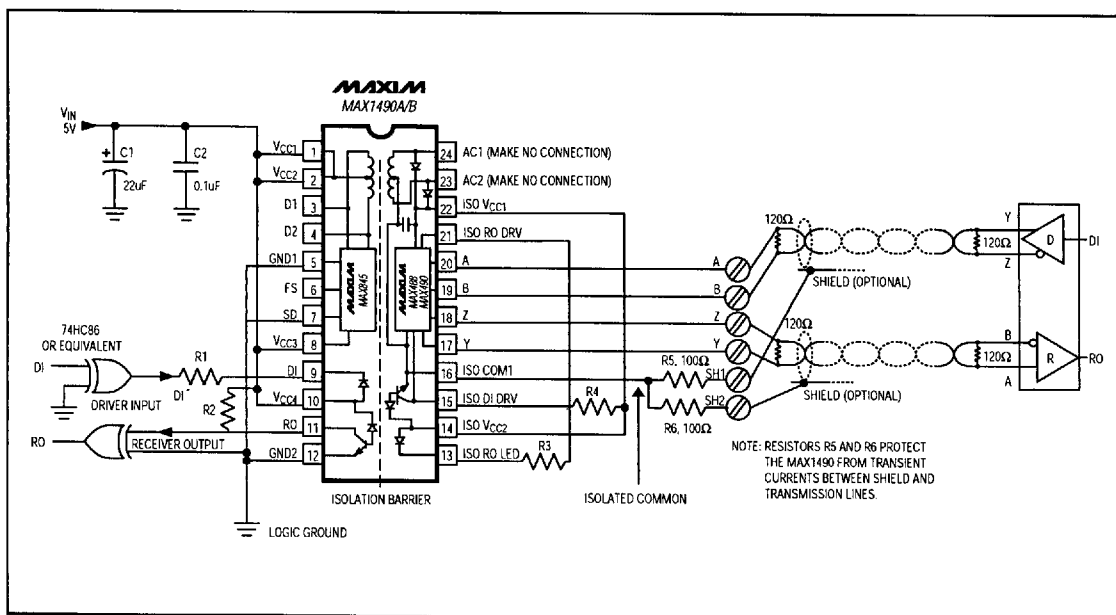

Figure 14. Typical Full-Duplex RS-485/RS-422 Network

## Complete, Isolated, RS-485/RS-422 Data Interface

and components from one side should not be located near those of the other side.

- A shield trace connected to the ground on each side of the barrier can help intercept capacitive currents that might otherwise couple into the signal path. In a double-sided or multilayer board, these shield traces should be present on all conductor layers.
- Try to maximize the width of the isolation barrier wherever possible; a clear space of at least 0.25 inches between ground and isolated common is suggested.

### Pull-Up and LED Drive Resistors

The MAX1480A/MAX1480B/MAX1490A/MAX1490B are specified and characterized using the resistor values shown in Table 1 of Figure 1 and Table 2 of Figure 2. Altering the recommended values can degrade performance.

The DI and DE (MAX1480A/B only) inputs are the cathodes of LEDs whose anodes are connected to the

supply. These points are best driven by a CMOS-logic gate with a series resistor to limit the current. The resistor values shown in Tables 1 and 2 are recommended when the 74HC86 gate or equivalent is used. These values may need to be adjusted if a driving gate with dissimilar series resistance is used.

All pull-up resistors are based on optocoupler specifications in order to optimize the devices' data-transfer rates.

### Isolated Common Connection

The isolated common may be completely floating with respect to the logic ground and the effective network ground. The receiver input resistors will cause the isolated common voltage to go to the mean voltage of the receiver inputs. If using shielded cable, tie the isolated common to the shield through a 100Ω resistor. In the case of the MAX1490, each shield should have its own 100Ω resistor (Figures 1, 2, 13, and 14).

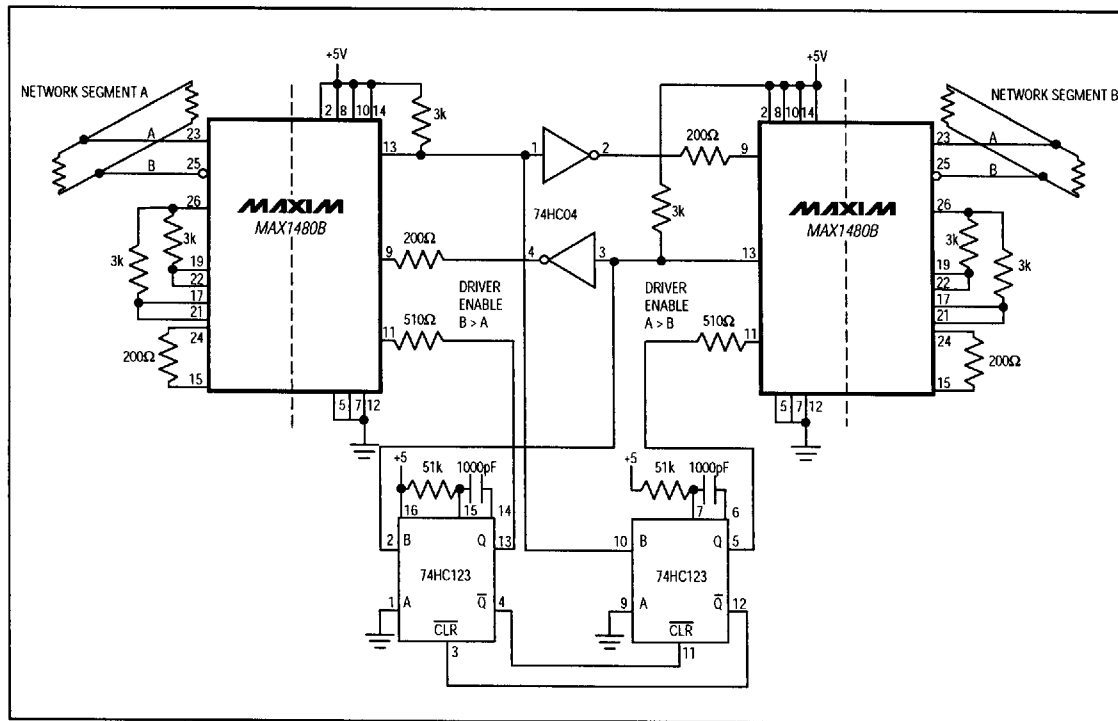

Figure 15. Doubly Isolated RS-485 Repeater

## Complete, Isolated, RS-485/RS-422 Data Interface

### **Doubly Isolated RS-485 Repeater**

The RS-422/RS-485 standard is specified for cable lengths up to 4000 feet. When approaching or exceeding the specified maximum cable length, a ground-potential difference of several tens of volts can easily develop. This difference can be either DC, AC, at power-line frequency, or any imaginable noise or impulse waveform. It is typically very low impedance so that if a connection between the two grounds is attempted, very large currents may flow. These currents are by their nature unstable and unpredictable. In addition, they may cause noise to be injected into sensitive instrumentation and, in severe cases, might actually cause physical damage to such equipment.

Figure 15 shows a half-duplex (two-wire), bidirectional, party-line repeater system that prevents interference and/or damage from ground-potential differences. Two MAX1480A/MAX1480B isolated RS-485 transceivers are used to isolate each of the network segments from the electrical environment of the repeater. The MAX1480A/MAX1480B also regenerate bus signals that may have been degraded by line attenuation or dispersion.

In the idle state, both transmitters are disabled, while all receivers in the system are enabled. If any device on the system has information for any other device, it starts sending its data onto the bus. Each data transmission on the bus retriggers the one-shot, keeping the sending transmitter enabled until there are no more transmissions. All receivers receive all data; if this is undesirable, the protocol must allow for an address field so receivers can ignore data not directed to them.

Each node must refrain from transmitting when data already exists on the bus, and must resend data that is corrupted by the collisions that inevitably occur with a party-line system. With the repeater of Figure 15, there might be transmitters up to 8000 feet apart. That represents more than 8 $\mu$ s (assuming 1ns/foot of delay) in which two nodes could be transmitting simultaneously.

The circuit in Figure 15 can be used either directly as shown, with the slew-rate-limited MAX1480B, for data transfer rates up to 250kbps, or with the MAX1480A for data rates up to 2.5Mbps (see Table 1 for pull-up and LED resistor values when using the MAX1480A). If dual-port isolation is not needed, one of the MAX1480 devices can be replaced by a MAX485 for 2.5Mbps applications, or by a MAX483 for 250kbps applications.

**MAX1480A/B, MAX1490A/B**

**MAX1480A/B, MAX1490A/B**

# Complete, Isolated, RS-485/RS-422 Data Interface

## Ordering Information (continued)

PART†	TEMP. RANGE	PIN-PACKAGE
MAX1480BCPI	0 °C to +70 °C	28 Wide Plastic DIP
MAX1480BEPI	-40 °C to +85 °C	28 Wide Plastic DIP
MAX1490ACPG	0 °C to +70 °C	24 Wide Plastic DIP
MAX1490AEPG	-40 °C to +85 °C	24 Wide Plastic DIP
MAX1490BCPG	0 °C to +70 °C	24 Wide Plastic DIP
MAX1490BEPG	-40 °C to +85 °C	24 Wide Plastic DIP

† Data rate for "A" parts is up to 2500kbps. Data rate for "B" parts is up to 250kbps.

## Pin Configurations (continued)

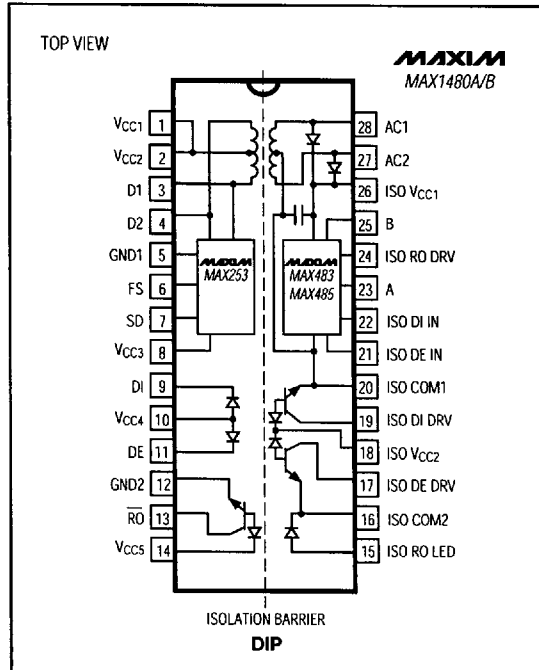

Maxim cannot assume responsibility for use of any circuitry other than circuitry entirely embodied in a Maxim product. No circuit patent licenses are implied. Maxim reserves the right to change the circuitry and specifications without notice at any time.

20 Maxim Integrated Products, 120 San Gabriel Drive, Sunnyvale, CA 94086 (408) 737-7600

© 1996 Maxim Integrated Products

Printed USA

MAXIM is a registered trademark of Maxim Integrated Products.