

Doc. Version	0.2
Total Page	15
Date	2008/06/30

Product Specification

5" COLOR TFT-LCD MODULE

MODEL NAME: A050FW01 V5

< >Preliminary Specification
< ◆ >Final Specification

**©2008 AU Optronics
All Rights Reserved.
DO NOT COPY**

Note: The content of this specification is subject to change.

Record of Revision

Version	Revise Date	Page	Content
0.0	01/10/2008		First draft.
0.1	2008/03/13	10 12	Response time(30ms) and Viewing Angle(L/R : 70/70) Low Temperature Storage(-30°C) and Operation(-20°C)
0.2	2008/06/30	14	Drawing update

Contents

<u>A. PHYSICAL SPECIFICATIONS</u>	3
<u>B. ELECTRICAL SPECIFICATIONS</u>	4
1. FPC PIN ASSIGNMENT	4
CONNECTOR: FH12-50S-0.5SH	4
2. ABSOLUTE MAXIMUM RATINGS	6
<u>C. ELECTRICAL CHARACTERISTICS</u>	6
1. TFT- LCD TYPICAL OPERATION CONDITION	6
2. BACKLIGHT DRIVING CONDITIONS	6
3. SUGGESTED APPLICATION CIRCUIT	7
3.1 SUGGESTED APPLICATION CIRCUIT	7
4. AC TIMING	8
4.1 TIMING DIAGRAM	8
4.2 TIMING CONDITION	8
5. POWER ON/OFF SEQUENCE	9
<u>D. OPTICAL SPECIFICATION</u>	10
<u>E. RELIABILITY TEST ITEMS:</u>	12
<u>F. PACKING FORM</u>	13
<u>G. OUTLINE DRAWING:</u>	14

A. Physical specifications

NO.	Item	Specification	Remark
1	Display Resolution (dot)	480RGB (H) X 272 (V)	
2	Active Area (mm)	109.44 (H) X 62.016 (V)	
3	Screen Size (inch)	4.95" (Diagonal)	
4	Dot Pitch (mm)	0.076 (H) X 0.228 (V)	
5	Color Configuration	R. G. B. Stripe	Note 1
6	Color Depth	16.7M Colors	Note 2
7	Overall Dimension (mm)	120.7 (H) X 75.8 (V) X 3.11 (T)	Note 3
8	Weight (g)	TBD	
9	Display Mode	Normally White	
10	Gray Level Inversion	6 O'clock	

Note 1: Below figure shows dot stripe arrangement.

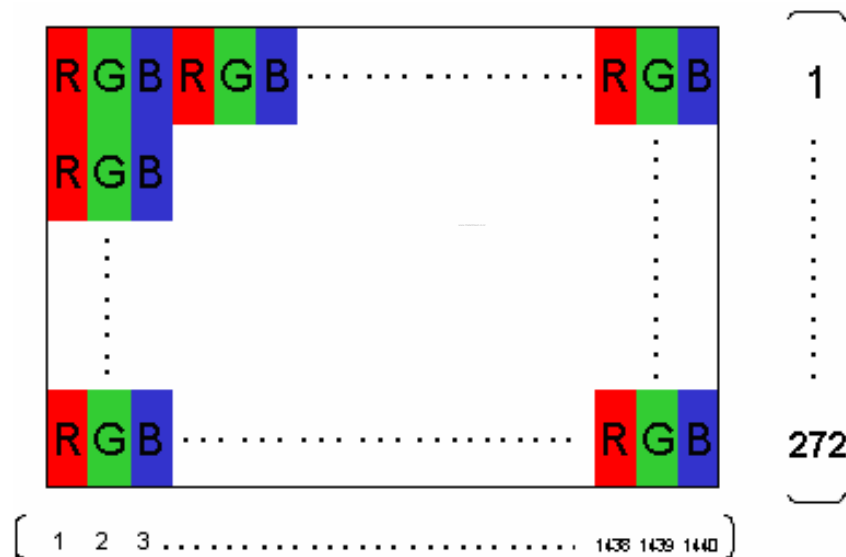

Note 2: Full color display depends on 8-bit data signal (pin 5~28).

Note 3: Not including FPC.

B. Electrical Specifications

1. FPC Pin Assignment

Connector: FH12-50S-0.5SH

Pin No.	Symbol	Type	Description	Remark
1	GND	P	Ground	
2	GND	P	Ground	
3	VDD	P	Power supply	
4	VDD	P	Power supply	
5	R0	I	Red data (LSB)	
6	R1	I	Red data	
7	R2	I	Red data	
8	R3	I	Red data	
9	R4	I	Red data	
10	R5	I	Red data	
11	R6	I	Red data	
12	R7	I	Red data (MSB)	
13	G0	I	Green data (LSB)	
14	G1	I	Green data	
15	G2	I	Green data	
16	G3	I	Green data	
17	G4	I	Green data	
18	G5	I	Green data	
19	G6	I	Green data	
20	G7	I	Green data (MSB)	
21	B0	I	Blue data (LSB)	
22	B1	I	Blue data	
23	B2	I	Blue data	
24	B3	I	Blue data	
25	B4	I	Blue data	
26	B5	I	Blue data	
27	B6	I	Blue data	

28	B7	I	Blue data (MSB)	
29	GND	P	Ground	
30	DCLK	I	Pixel clock	Note 2
31	DISP	I	DISP : 'L' → Display OFF DISP : 'H' → Display ON	Note 2
32	NC		None Connect	
33	NC		None Connect	
34	DE	I	Data Enable	Note 2
35	U/D	I	Shift Up or Down Control	Note 3
36	NC		None Connect	
37	GND	P	Ground	
38	GND	P	Ground	
39	NC		Not Connected	
40	NC		Not Connected	
41	NC		Not Connected	
42	NC		Not Connected	
43	GND	P	Ground	
44	GND	P	Ground	
45	GND	P	Ground	
46	VLED-	P	LED cathode	
47	VLED+	P	LED anode	
48	GND	P	Ground	
49	GND	P	Ground	
50	GND	P	Ground	

Note 1: I: Input; O: Output; P: Power.

Note 2: For correct power on sequence please refer to section 5 “Power On/Off Sequence”

Note 3: U/D="H" displays up to down and left to right. U/D="L" displays down to up and right to left.

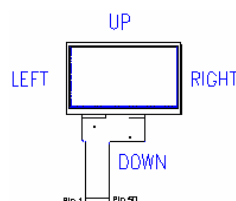

2. Absolute Maximum Ratings

Item	Symbol	Min.	Max.	Unit	Remark
Power voltage	Vdd	-0.3	4.5	V	Note 1
Input signal voltage	Vi	-0.3	Vdd+ 0.3	V	

Note 1: Functional operation should be restricted under normal ambient temperature.

C. Electrical Characteristics

The following items are measured under stable condition and suggested application circuit.

1. TFT- LCD Typical Operation Condition

Item	Symbol	Min.	Typ.	Max.	Unit	Remark
Power supply	Vdd	3.1	3.3	3.5	V	
Input high voltage	Vh	0.7*Vdd	-	Vdd	V	
Input low voltage	Vi	0	-	0.3*Vdd		
Vertical cycle	f_V	-	59.94	-	Hz	
Horizontal cycle	f_H	-	17.14	-	kHz	
Dot Frequency	f_{DCLK}	-	9.0	15.0	MHz	

2. Backlight Driving Conditions

Parameter	Symbol	Min.	Typ.	Max.	Unit	Remark
LED Current	I_L	-	20	-	mA	single serial
LED Voltage	V_L	-	23.1	-	V	single serial
LED Life Time	L_L	-	-	-	Hr	Note 2, 3

Note 1: LED backlight is 14 LEDs.

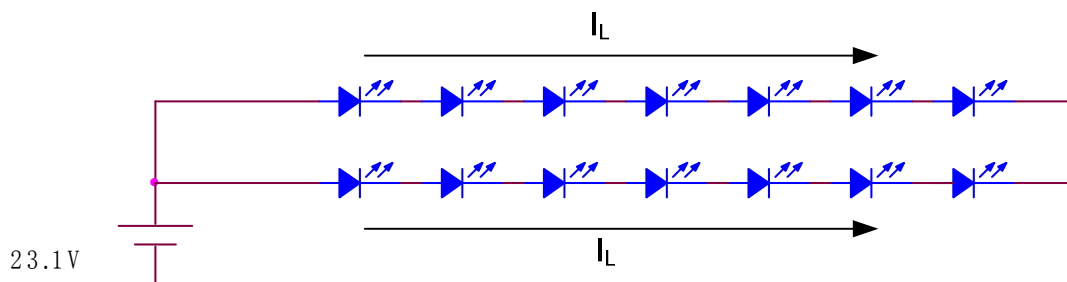

Note 2 :Define “LED Lifetime”: brightness is decreased to 50% of the initial value. LED Lifetime is restricted under normal condition, ambient temperature = 25°C and LED current = 20mA.

Note 3: If it uses larger LED current IL more than 20mA, it maybe decreases the LED lifetime.

3. Suggested Application Circuit
3.1 Suggested Application Circuit

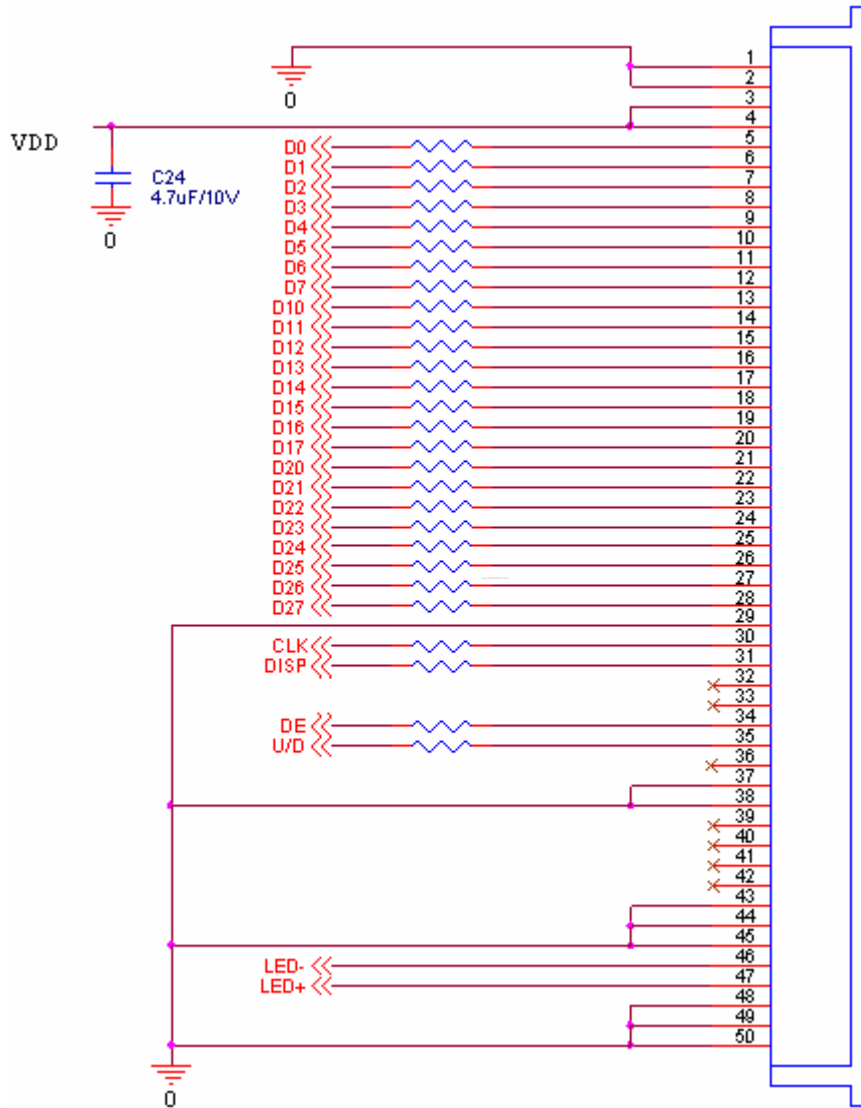

NOTE: Resistors = 120ohm

4. AC Timing

4.1 Timing Diagram

4.1.1 Vertical Timing of Input

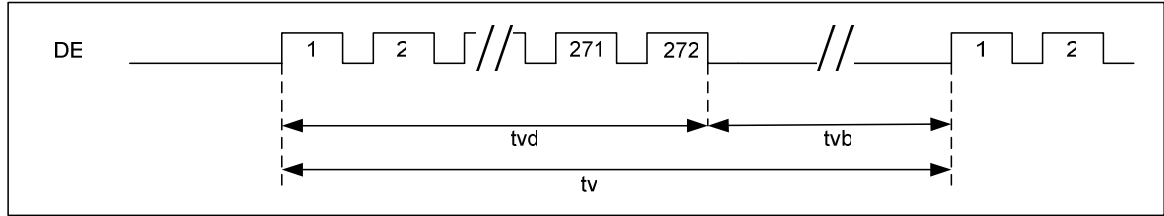

4.1.2 Horizontal Timing of Input

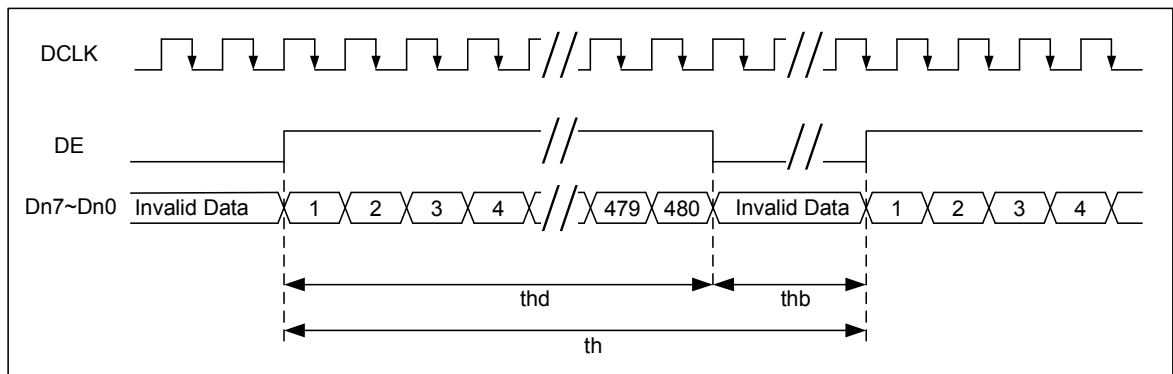

4.2 Timing Condition

4.2.1. Timing Parameters

PARAMETER	Symbol	Min	Typ	Max	Unit
Clock cycle	1/ t_c	-	9	15	MHz
Horizontal cycle	1/ f_h	-	17.14	-	KHz
Vertical cycle	1/ f_v	-	59.94	-	Hz
Horizontal Signal					
Horizontal cycle *1	t_h	-	525	-	DCLK
Horizontal display period	t_{hd}	-	480	-	DCLK
Horizontal blank	t_{hb}	-	45	-	DCLK
Vertical Signal					
Vertical cycle	t_v	-	286	-	H
Vertical display period	t_{vd}	-	272	-	H
Vertical blank	t_{vb}	-	14	-	H

5. Power On/Off Sequence

A. The LCD adopts high voltage driver IC, so it could be permanently damaged under a wrong power on/off sequence. The suggested LCD power sequence is below:

Power on sequence: VDD→DCLK→DISP→LED UNIT.

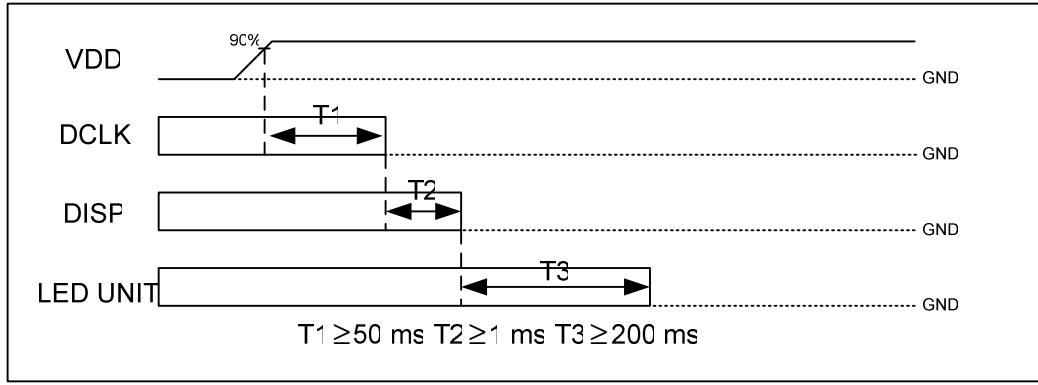

Power off sequence: LED UNIT→DISP →DCLK→ VDD.

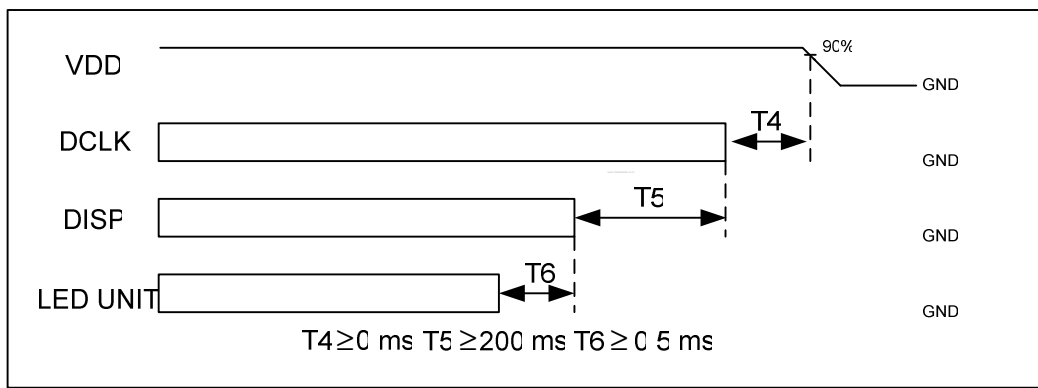

B. Signals DCLK, DISP and DE must be pulled low at power on. Any power on glitches at these signal can cause abnormal display. Below is an example of DE signal demonstrating a signal glitch power on and a correct signal power on.

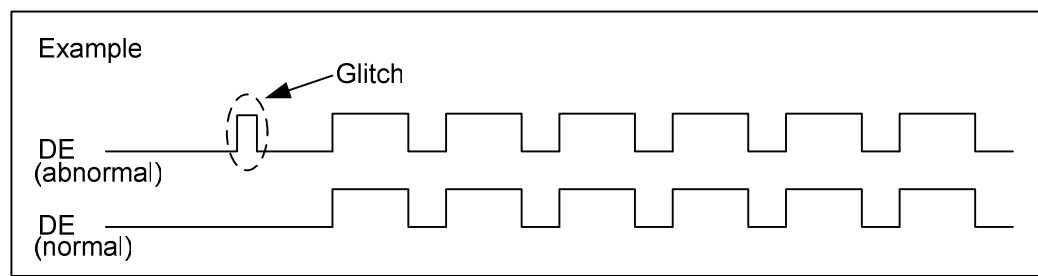

D. Optical specification

Item	Symbol	Condition	Min.	Typ.	Max.	Unit	Remark
Response Time							
Rise	Tr	$\theta=0^\circ$	-	7	-	ms	Note 4, 5
Fall	Tf		-	23	-	ms	
Contrast ratio	CR	At optimized viewing	-	300	-		Note 6, 7
Viewing Angle							
Top		$CR \geq 10$	-	40	-	deg.	Note 8
Bottom			-	60	-		
Left			-	70	-		
Right			-	70	-		
Brightness	Y_L	$\theta=0^\circ$	420	500	-	cd/m ²	Note 9
White Chromaticity	X	$\theta=0^\circ$	0.26	0.31	0.36		
	y	$\theta=0^\circ$	0.28	0.33	0.38		

Note 1: Measurement is in the dark room, optical ambient temperature =25°C, and backlight current IL=20 mA

Note 2: To be measured in the dark room.

Note 3: To be measured on the center area of panel with a field angle of 1° by Topcon luminance meter BM-7, after 10 minutes operation.

Note 4: Definition of response time:

The output signals of photo detector are measured when the input signals are changed from “black” to “white”(falling time) and from “white” to “black”(rising time), respectively.

Note 5. From liquid crystal characteristics, response time will become slower and the color of panel will become darker when ambient temperature is below 25°C.

Note 6. Definition of contrast ratio:

$$\text{Contrast ratio (CR)} = \frac{\text{Photo detector output when LCD is at "White" state}}{\text{Photo detector output when LCD is at "Black" state}}$$

Note 7. White $V_i = V_{i50} \mp 1.5V$

Black $V_i = V_{i50} \pm 2.0V$

“±” means that the analog input signal swings in phase with COM signal.

“∓” means that the analog input signal swings out of phase with COM signal.

V_{i50} : The analog input voltage when transmission is 50%

The 100% transmission is defined as the transmission of LCD panel when all the input terminals of module are electrically opened.

Note 8. Definition of viewing angle: refer to figure as below.

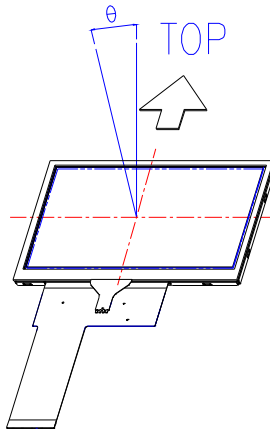

Note 9. Measured at the center area of the panel when all the input terminals of LCD panel are electrically opened.

E. Reliability test items:

No.	Test items	Conditions	Remark
1	High Temperature Storage	Ta= 80°C 240Hrs	
2	Low Temperature Storage	Ta= -30°C 240Hrs	
3	High Temperature Operation	Tp= 70°C 240Hrs	
4	Low Temperature Operation	Ta= -20°C 240Hrs	
5	High Temperature & High	Tp= 60°C, 90% RH 240Hrs	Operation
6	Heat Shock	-10°C~70°C/50 cycles 2Hrs/cycle	
7	Electrostatic Discharge	±200V,200pF(0Ω), once for each terminal	
8	Vibration	Frequency range 10~55Hz Stoke 1.5mm Sweep 10~55~10Hz 2 hours for each direction of X,Y,Z Ta= 25°C	Non-operation JIS C7021, A-10 condition A 2 hours for each direction of X,Y,Z (6 hours for total)
9	Mechanical Shock	100G . 6ms, ±X,±Y,±Z 3 times for each direction	Non-operation JIS C7021, A-7 condition C
10	Vibration (With Carton)	Random vibration: 0.015G ² /Hz from 5~200Hz -6dB/Octave from 200~500Hz	IEC 68-34
11	Drop (With Carton)	Height: 60cm 1 corner, 3 edges, 6 surfaces	

Note 1: Ta: Ambient Temperature.

Note 2: Squarely inspect all LCD function before and after ambient environment test.

Note 3: In the standard conditions, there is not display function NG issue occurred. All the cosmetic specification is judged before the reliability stress.

F. Packing Form

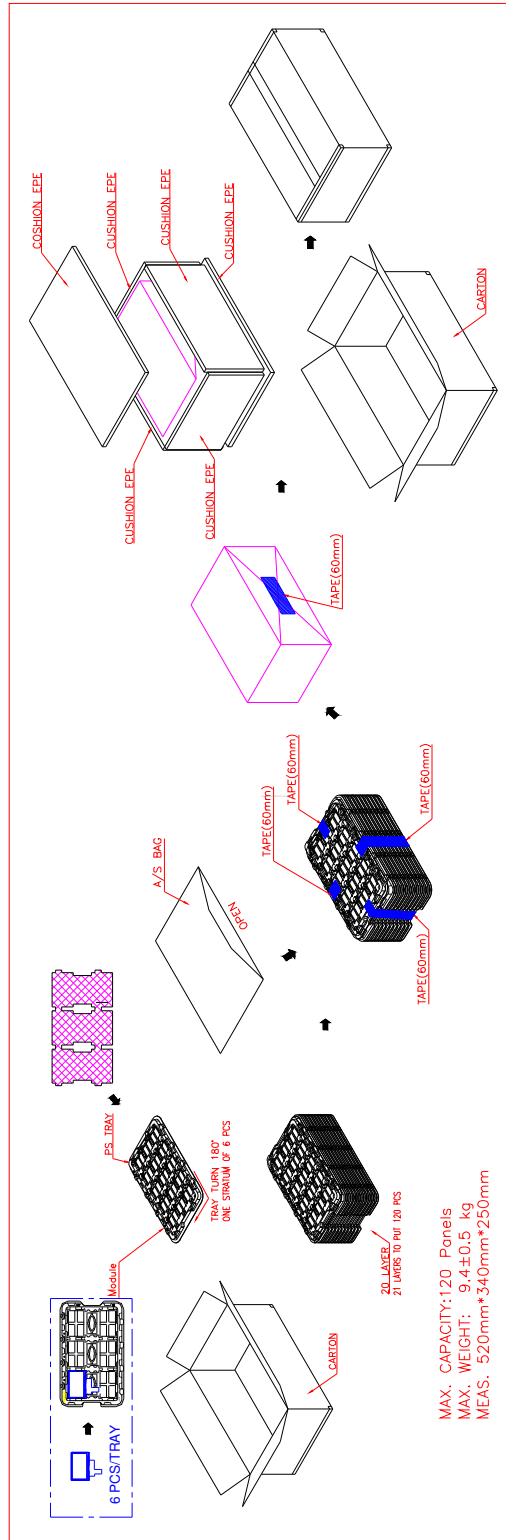

G. Outline Drawing:

