

To all our customers

---

## **Regarding the change of names mentioned in the document, such as Hitachi Electric and Hitachi XX, to Renesas Technology Corp.**

---

The semiconductor operations of Mitsubishi Electric and Hitachi were transferred to Renesas Technology Corporation on April 1st 2003. These operations include microcomputer, logic, analog and discrete devices, and memory chips other than DRAMs (flash memory, SRAMs etc.) Accordingly, although Hitachi, Hitachi, Ltd., Hitachi Semiconductors, and other Hitachi brand names are mentioned in the document, these names have in fact all been changed to Renesas Technology Corp. Thank you for your understanding. Except for our corporate trademark, logo and corporate statement, no changes whatsoever have been made to the contents of the document, and these changes do not constitute any alteration to the contents of the document itself.

Renesas Technology Home Page: <http://www.renesas.com>

Renesas Technology Corp.  
Customer Support Dept.  
April 1, 2003

## Cautions

Keep safety first in your circuit designs!

1. Renesas Technology Corporation puts the maximum effort into making semiconductor products better and more reliable, but there is always the possibility that trouble may occur with them. Trouble with semiconductors may lead to personal injury, fire or property damage.  
Remember to give due consideration to safety when making your circuit designs, with appropriate measures such as (i) placement of substitutive, auxiliary circuits, (ii) use of nonflammable material or (iii) prevention against any malfunction or mishap.

Notes regarding these materials

1. These materials are intended as a reference to assist our customers in the selection of the Renesas Technology Corporation product best suited to the customer's application; they do not convey any license under any intellectual property rights, or any other rights, belonging to Renesas Technology Corporation or a third party.
2. Renesas Technology Corporation assumes no responsibility for any damage, or infringement of any third-party's rights, originating in the use of any product data, diagrams, charts, programs, algorithms, or circuit application examples contained in these materials.
3. All information contained in these materials, including product data, diagrams, charts, programs and algorithms represents information on products at the time of publication of these materials, and are subject to change by Renesas Technology Corporation without notice due to product improvements or other reasons. It is therefore recommended that customers contact Renesas Technology Corporation or an authorized Renesas Technology Corporation product distributor for the latest product information before purchasing a product listed herein.  
The information described here may contain technical inaccuracies or typographical errors. Renesas Technology Corporation assumes no responsibility for any damage, liability, or other loss rising from these inaccuracies or errors.  
Please also pay attention to information published by Renesas Technology Corporation by various means, including the Renesas Technology Corporation Semiconductor home page (<http://www.renesas.com>).
4. When using any or all of the information contained in these materials, including product data, diagrams, charts, programs, and algorithms, please be sure to evaluate all information as a total system before making a final decision on the applicability of the information and products. Renesas Technology Corporation assumes no responsibility for any damage, liability or other loss resulting from the information contained herein.
5. Renesas Technology Corporation semiconductors are not designed or manufactured for use in a device or system that is used under circumstances in which human life is potentially at stake. Please contact Renesas Technology Corporation or an authorized Renesas Technology Corporation product distributor when considering the use of a product contained herein for any specific purposes, such as apparatus or systems for transportation, vehicular, medical, aerospace, nuclear, or undersea repeater use.
6. The prior written approval of Renesas Technology Corporation is necessary to reprint or reproduce in whole or in part these materials.
7. If these products or technologies are subject to the Japanese export control restrictions, they must be exported under a license from the Japanese government and cannot be imported into a country other than the approved destination.  
Any diversion or reexport contrary to the export control laws and regulations of Japan and/or the country of destination is prohibited.
8. Please contact Renesas Technology Corporation for further details on these materials or the products contained therein.

Hitachi Single-Chip Microcomputer

H8S/2276 Series

H8S/2277F-ZTAT™

HD64F2277

Hardware Manual

**RENESAS**

ADE-602-224

Rev. 1.0

12/26/01

Hitachi Ltd.

## Cautions

1. Hitachi neither warrants nor grants licenses of any rights of Hitachi's or any third party's patent, copyright, trademark, or other intellectual property rights for information contained in this document. Hitachi bears no responsibility for problems that may arise with third party's rights, including intellectual property rights, in connection with use of the information contained in this document.
2. Products and product specifications may be subject to change without notice. Confirm that you have received the latest product standards or specifications before final design, purchase or use.
3. Hitachi makes every attempt to ensure that its products are of high quality and reliability. However, contact Hitachi's sales office before using the product in an application that demands especially high quality and reliability or where its failure or malfunction may directly threaten human life or cause risk of bodily injury, such as aerospace, aeronautics, nuclear power, combustion control, transportation, traffic, safety equipment or medical equipment for life support.
4. Design your application so that the product is used within the ranges guaranteed by Hitachi particularly for maximum rating, operating supply voltage range, heat radiation characteristics, installation conditions and other characteristics. Hitachi bears no responsibility for failure or damage when used beyond the guaranteed ranges. Even within the guaranteed ranges, consider normally foreseeable failure rates or failure modes in semiconductor devices and employ systemic measures such as fail-safes, so that the equipment incorporating Hitachi product does not cause bodily injury, fire or other consequential damage due to operation of the Hitachi product.
5. This product is not designed to be radiation resistant.
6. No one is permitted to reproduce or duplicate, in any form, the whole or part of this document without written approval from Hitachi.
7. Contact Hitachi's sales office for any questions regarding this document or Hitachi semiconductor products.

# Preface

This LSI is a single-chip microcomputer made up of the H8S/2000 CPU with an internal 32-bit architecture as its core, and the peripheral functions required to configure a system.

This LSI is equipped with ROM, RAM, a bus controller, data transfer controller (DTC), three types of timers, a serial communication interface (SCI), an A/D converter, FLEX™\*1 decoder II, and I/O ports as on-chip supporting modules. This LSI is suitable for use as an embedded processor for high-level control systems. Its on-chip ROM is flash memory (F-ZTAT™\*2) that provides flexibility as it can be reprogrammed in no time to cope with all situations from the early stages of mass production to full-scale mass production. This is particularly applicable to application devices with specifications that will most probably change.

Note: \*1 FLEX™ is a trademark of Motorola.

\*2 F-ZTAT™ is a trademark of Hitachi, Ltd.

**Target Users:** This manual was written for users who will be using the H8S/2276 Series in the design of application systems. Members of this audience are expected to understand the fundamentals of electrical circuits, logical circuits, and microcomputers.

**Objective:** This manual was written to explain the hardware functions and electrical characteristics of the H8S/2276 Series to the above audience. Refer to the H8S/2600 Series, H8S/2000 Series Programming Manual for a detailed description of the instruction set.

Notes on reading this manual:

- In order to understand the overall functions of the chip  
Read the manual according to the contents. This manual can be roughly categorized into parts on the CPU, system control functions, peripheral functions and electrical characteristics.
- In order to understand the details of the CPU's functions  
Read the H8S/2600 Series, H8S/2000 Series Programming Manual.
- In order to understand the details of a register when its name is known  
The addresses, bits, and initial values of the registers are summarized in Appendix B, Internal I/O Registers.

Example: Bit order: The MSB is on the left and the LSB is on the right.

**Related Manuals:** The latest versions of all related manuals are available from our web site. Please ensure you have the latest versions of all documents you require.  
<http://www.hitachisemiconductor.com/>

H8S/2276 Series manuals:

<b>Manual Title</b>	<b>ADE No.</b>
H8S/2276 Series Hardware Manual	This manual
H8S/2600 Series, H8S/2000 Series Programming Manual	ADE-602-083

Users manuals for development tools:

<b>Manual Title</b>	<b>ADE No.</b>
C/C++ Compiler, Assembler, Optimized Linkage Editor User's Manual	ADE-702-247
Simulator Debugger Users Manual	ADE-702-037
Hitachi Embedded Workshop Users Manual	ADE-702-231

Application Notes:

<b>Manual Title</b>	<b>ADE No.</b>
H8S Series Technical Q & A	ADE-502-059

# Contents

Section 1	Overview .....	1
1.1	Overview.....	1
1.2	Internal Block Diagrams.....	6
1.3	Pin Description .....	7
1.3.1	Pin Arrangements .....	7
1.3.2	Pin Functions in Each Operating Mode.....	8
1.3.3	Pin Functions.....	12
Section 2	CPU .....	17
2.1	Overview.....	17
2.1.1	Features .....	17
2.1.2	Differences between H8S/2600 CPU and H8S/2000 CPU .....	18
2.1.3	Differences from H8/300 CPU .....	19
2.1.4	Differences from H8/300H CPU .....	19
2.2	CPU Operating Modes .....	20
2.3	Address Space.....	25
2.4	Register Configuration .....	26
2.4.1	Overview .....	26
2.4.2	General Registers.....	27
2.4.3	Control Registers.....	28
2.4.4	Initial Register Values .....	30
2.5	Data Formats.....	31
2.5.1	General Register Data Formats .....	31
2.5.2	Memory Data Formats.....	33
2.6	Instruction Set.....	34
2.6.1	Overview .....	34
2.6.2	Instructions and Addressing Modes .....	35
2.6.3	Table of Instructions Classified by Function.....	37
2.6.4	Basic Instruction Formats.....	44
2.6.5	Notes on Use of Bit-Manipulation Instructions.....	45
2.7	Addressing Modes and Effective Address Calculation .....	45
2.7.1	Addressing Mode.....	45
2.7.2	Effective Address Calculation.....	48
2.8	Processing States .....	52
2.8.1	Overview .....	52
2.8.2	Reset State .....	53
2.8.3	Exception-Handling State .....	54
2.8.4	Program Execution State .....	57
2.8.5	Bus-Released State .....	57

2.8.6	Power-Down State.....	57
2.9	Basic Timing.....	58
2.9.1	Overview .....	58
2.9.2	On-Chip Memory (ROM, RAM) .....	58
2.9.3	On-Chip Supporting Module Access Timing.....	60
2.9.4	External Address Space Access Timing.....	61
2.10	Usage Note .....	62
2.10.1	STM/LDM Instruction.....	62
<b>Section 3</b>	<b>MCU Operating Modes .....</b>	<b>63</b>
3.1	Overview.....	63
3.1.1	Operating Mode Selection.....	63
3.1.2	Register Configuration .....	64
3.2	Register Descriptions.....	64
3.2.1	Mode Control Register (MDCR).....	64
3.2.2	System Control Register (SYSCR) .....	65
3.3	Operating Mode Descriptions.....	66
3.3.1	Mode 4.....	66
3.3.2	Mode 5.....	66
3.3.3	Mode 6.....	67
3.3.4	Mode 7.....	67
3.4	Pin Functions in Each Operating Mode .....	68
3.5	Memory Map in Each Operating Mode.....	68
<b>Section 4</b>	<b>Exception Handling.....</b>	<b>71</b>
4.1	Overview.....	71
4.1.1	Exception Handling Types and Priority .....	71
4.1.2	Exception Handling Operation .....	72
4.1.3	Exception Sources and Vector Table .....	72
4.2	Reset .....	74
4.2.1	Overview .....	74
4.2.2	Reset Sequence .....	74
4.2.3	Interrupts after Reset .....	76
4.2.4	State of On-Chip Supporting Modules after Reset Release .....	76
4.3	Traces .....	77
4.4	Interrupts.....	78
4.5	Trap Instruction .....	79
4.6	Stack Status after Exception Handling.....	80
4.7	Notes on Use of the Stack.....	81
<b>Section 5</b>	<b>Interrupt Controller .....</b>	<b>83</b>
5.1	Overview.....	83
5.1.1	Features .....	83



5.1.2	Block Diagram.....	84
5.1.3	Pin Configuration .....	84
5.1.4	Register Configuration .....	85
5.2	Register Descriptions.....	85
5.2.1	System Control Register (SYSCR) .....	85
5.2.2	Interrupt Priority Registers A to G, I to K, O (IPRA to IPRG, IPRI to IPRK, IPRO) .....	86
5.2.3	IRQ Enable Register (IER) .....	88
5.2.4	IRQ Sense Control Registers H and L (ISCRH, ISCRL).....	88
5.2.5	IRQ Status Register (ISR).....	89
5.3	Interrupt Sources.....	90
5.3.1	External Interrupts.....	90
5.3.2	Internal Interrupts .....	92
5.3.3	Interrupt Exception Handling Vector Table .....	92
5.4	Interrupt Operation .....	95
5.4.1	Interrupt Control Modes and Interrupt Operation .....	95
5.4.2	Interrupt Control Mode 0.....	98
5.4.3	Interrupt Control Mode 2.....	100
5.4.4	Interrupt Exception Handling Sequence .....	102
5.4.5	Interrupt Response Times.....	103
5.5	Usage Notes .....	104
5.5.1	Contention between Interrupt Generation and Disabling .....	104
5.5.2	Instructions that Disable Interrupts .....	105
5.5.3	Times when Interrupts are Disabled.....	105
5.5.4	Interrupts during Execution of EEPMOV Instruction.....	105
5.6	DTC Activation by Interrupt .....	106
5.6.1	Overview .....	106
5.6.2	Block Diagram.....	106
5.6.3	Operation.....	107
Section 6 PC Break Controller (PBC).....		109
6.1	Overview.....	109
6.1.1	Features .....	109
6.1.2	Block Diagram.....	110
6.1.3	Register Configuration .....	111
6.2	Register Descriptions.....	111
6.2.1	Break Address Register A (BARA) .....	111
6.2.2	Break Address Register B (BARB).....	112
6.2.3	Break Control Register A (BCRA) .....	112
6.2.4	Break Control Register B (BCRB).....	114
6.2.5	Module Stop Control Register C (MSTPCRC).....	114
6.3	Operation .....	115
6.3.1	PC Break Interrupt Due to Instruction Fetch.....	115

6.3.2	PC Break Interrupt Due to Data Access .....	115
6.3.3	Notes on PC Break Interrupt Handling .....	116
6.3.4	Operation in Transitions to Power-Down Modes .....	116
6.3.5	PC Break Operation in Continuous Data Transfer .....	117
6.3.6	When Instruction Execution is Delayed by One State .....	118
6.3.7	Additional Notes .....	119
<b>Section 7</b>	<b>Bus Controller.....</b>	<b>121</b>
7.1	Overview.....	121
7.1.1	Features .....	121
7.1.2	Block Diagram.....	122
7.1.3	Pin Configuration .....	123
7.1.4	Register Configuration .....	124
7.2	Register Descriptions.....	124
7.2.1	Bus Width Control Register (ABWCR).....	124
7.2.2	Access State Control Register (ASTCR).....	125
7.2.3	Wait Control Registers H and L (WCRH, WCRL).....	126
7.2.4	Bus Control Register H (BCRH).....	129
7.2.5	Bus Control Register L (BCRL).....	131
7.2.6	Pin Function Control Register (PFCR) .....	132
7.3	Overview of Bus Control.....	134
7.3.1	Area Partitioning .....	134
7.3.2	Bus Specifications .....	135
7.3.3	Memory Interfaces.....	136
7.3.4	Interface Specifications for Each Area.....	136
7.3.5	Chip Select Signals.....	137
7.4	Basic Bus Interface.....	139
7.4.1	Overview .....	139
7.4.2	Data Size and Data Alignment .....	139
7.4.3	Valid Strobes .....	140
7.4.4	Basic Timing .....	141
7.4.5	Wait Control .....	149
7.5	Burst ROM Interface .....	151
7.5.1	Overview .....	151
7.5.2	Basic Timing .....	151
7.5.3	Wait Control .....	153
7.6	Idle Cycle.....	154
7.6.1	Operation .....	154
7.6.2	Pin States in Idle Cycle.....	156
7.7	Bus Release.....	157
7.7.1	Overview .....	157
7.7.2	Operation .....	157
7.7.3	Pin States in External Bus Released State.....	158

7.7.4	Transition Timing.....	159
7.7.5	Usage Note .....	160
7.8	Bus Arbitration .....	160
7.8.1	Overview .....	160
7.8.2	Operation .....	160
7.8.3	Bus Transfer Timing .....	161
7.8.4	External Bus Release Usage Note.....	161
7.9	Resets and the Bus Controller.....	161
<b>Section 8 Data Transfer Controller (DTC) .....</b>		<b>163</b>
8.1	Overview.....	163
8.1.1	Features .....	163
8.1.2	Block Diagram.....	164
8.1.3	Register Configuration .....	165
8.2	Register Descriptions.....	166
8.2.1	DTC Mode Register A (MRA).....	166
8.2.2	DTC Mode Register B (MRB) .....	167
8.2.3	DTC Source Address Register (SAR).....	168
8.2.4	DTC Destination Address Register (DAR).....	169
8.2.5	DTC Transfer Count Register A (CRA) .....	169
8.2.6	DTC Transfer Count Register B (CRB) .....	169
8.2.7	DTC Enable Registers (DTCER) .....	170
8.2.8	DTC Vector Register (DTVECR).....	171
8.2.9	Module Stop Control Register A (MSTPCRA).....	172
8.3	Operation .....	173
8.3.1	Overview .....	173
8.3.2	Activation Sources.....	175
8.3.3	DTC Vector Table.....	176
8.3.4	Location of Register Information in Address Space .....	179
8.3.5	Normal Mode.....	180
8.3.6	Repeat Mode .....	181
8.3.7	Block Transfer Mode.....	182
8.3.8	Chain Transfer.....	184
8.3.9	Operation Timing .....	185
8.3.10	Number of DTC Execution States.....	186
8.3.11	Procedures for Using DTC .....	187
8.3.12	Examples of Use of the DTC.....	188
8.4	Interrupts.....	190
8.5	Usage Notes .....	190
<b>Section 9 I/O Ports .....</b>		<b>191</b>
9.1	Overview.....	191
9.2	Port 1.....	194

9.2.1	Overview .....	194
9.2.2	Register Configuration .....	195
9.2.3	Pin Functions.....	197
9.3	Port 3.....	203
9.3.1	Overview .....	203
9.3.2	Register Configuration .....	204
9.3.3	Pin Functions.....	206
9.4	Port 4.....	208
9.4.1	Overview .....	208
9.4.2	Register Configuration .....	209
9.4.3	Pin Functions.....	209
9.5	Port 7 [Internal I/O Port].....	210
9.5.1	Overview .....	210
9.5.2	Register Configuration .....	211
9.5.3	Pin Functions.....	213
9.6	Port A.....	214
9.6.1	Overview .....	214
9.6.2	Register Configuration .....	214
9.6.3	Pin Functions.....	218
9.6.4	MOS Input Pull-Up Function .....	219
9.7	Port B.....	220
9.7.1	Overview .....	220
9.7.2	Register Configuration .....	221
9.7.3	Pin Functions.....	223
9.7.4	MOS Input Pull-Up Function .....	226
9.8	Port C.....	227
9.8.1	Overview .....	227
9.8.2	Register Configuration .....	228
9.8.3	Pin Functions in Each Mode .....	230
9.8.4	MOS Input Pull-Up Function .....	232
9.9	Port D.....	233
9.9.1	Overview .....	233
9.9.2	Register Configuration .....	234
9.9.3	Pin Functions in Each Mode .....	236
9.9.4	MOS Input Pull-Up Function .....	237
9.10	Port E.....	238
9.10.1	Overview .....	238
9.10.2	Register Configuration .....	239
9.10.3	Pin Functions in Each Mode .....	241
9.10.4	MOS Input Pull-Up Function .....	242
9.11	Port F.....	243
9.11.1	Overview .....	243
9.11.2	Register Configuration .....	244

9.11.3	Pin Functions.....	246
9.12	Port G.....	248
9.12.1	Overview .....	248
9.12.2	Register Configuration .....	249
9.12.3	Pin Functions.....	251
<b>Section 10</b>	<b>16-Bit Timer Pulse Unit (TPU).....</b>	<b>253</b>
10.1	Overview.....	253
10.1.1	Features .....	253
10.1.2	Block Diagram.....	257
10.1.3	Pin Configuration .....	258
10.1.4	Register Configuration .....	259
10.2	Register Descriptions.....	260
10.2.1	Timer Control Register (TCR) .....	260
10.2.2	Timer Mode Register (TMDR) .....	264
10.2.3	Timer I/O Control Register (TIOR) .....	266
10.2.4	Timer Interrupt Enable Register (TIER) .....	273
10.2.5	Timer Status Register (TSR).....	275
10.2.6	Timer Counter (TCNT) .....	278
10.2.7	Timer General Register (TGR) .....	278
10.2.8	Timer Start Register (TSTR).....	279
10.2.9	Timer Synchro Register (TSYR).....	280
10.2.10	Module Stop Control Register A (MSTPCRA).....	281
10.3	Interface to Bus Master.....	282
10.3.1	16-Bit Registers.....	282
10.3.2	8-Bit Registers.....	282
10.4	Operation .....	284
10.4.1	Overview .....	284
10.4.2	Basic Functions .....	285
10.4.3	Synchronous Operation .....	291
10.4.4	Buffer Operation .....	293
10.4.5	PWM Modes .....	296
10.4.6	Phase Counting Mode .....	301
10.5	Interrupts.....	307
10.5.1	Interrupt Sources and Priorities .....	307
10.5.2	DTC Activation .....	308
10.5.3	A/D Converter Activation .....	308
10.6	Operation Timing .....	309
10.6.1	Input/Output Timing .....	309
10.6.2	Interrupt Signal Timing .....	313
10.7	Usage Notes .....	317

Section 11	8-Bit Timers (TMR)	327
11.1	Overview	327
11.1.1	Features	327
11.1.2	Block Diagram	328
11.1.3	Register Configuration	329
11.2	Register Descriptions	330
11.2.1	Timer Counters 0 and 1 (TCNT0, TCNT1)	330
11.2.2	Time Constant Registers A0 and A1 (TCORA0, TCORA1)	330
11.2.3	Time Constant Registers B0 and B1 (TCORB0, TCORB1)	331
11.2.4	Timer Control Registers 0 and 1 (TCR0, TCR1)	331
11.2.5	Timer Control/Status Registers 0 and 1 (TCSR0, TCSR1)	334
11.2.6	Module Stop Control Register A (MSTPCRA)	336
11.3	Operation	337
11.3.1	TCNT Increment Timing	337
11.3.2	Compare Match Timing	337
11.3.3	Timing of Overflow Flag (OVF) Setting	339
11.3.4	Operation with Cascaded Connection	339
11.4	Interrupts	340
11.4.1	Interrupt Sources and DTC Activation	340
11.4.2	A/D Converter Activation	340
11.5	Sample Application	341
11.6	Usage Notes	342
11.6.1	Contention between TCNT Write and Clear	342
11.6.2	Contention between TCNT Write and Increment	343
11.6.3	Contention between TCOR Write and Compare Match	344
11.6.4	Switching of Internal Clocks and TCNT Operation	344
11.6.5	Interrupts and Module Stop Mode	346
Section 12	Watchdog Timer (WDT)	347
12.1	Overview	347
12.1.1	Features	347
12.1.2	Block Diagram	348
12.1.3	Pin Configuration	349
12.1.4	Register Configuration	350
12.2	Register Descriptions	351
12.2.1	Timer Counter (TCNT)	351
12.2.2	Timer Control/Status Register (TCSR)	351
12.2.3	Reset Control/Status Register (RSTCSR) (WDT0 Only)	356
12.2.4	Pin Function Control Register (PFCR)	357
12.2.5	Notes on Register Access	358
12.3	Operation	359
12.3.1	Watchdog Timer Operation	359
12.3.2	Interval Timer Operation	360

12.3.3	Timing of Setting of Overflow Flag (OVF) .....	361
12.3.4	Timing of Setting of Watchdog Timer Overflow Flag (WOVF) .....	362
12.4	Interrupts.....	362
12.5	Usage Notes .....	363
12.5.1	Contention between Timer Counter (TCNT) Write and Increment .....	363
12.5.2	Changing Value of PSS and CKS2 to CKS0.....	363
12.5.3	Switching between Watchdog Timer Mode and Interval Timer Mode.....	363
12.5.4	Internal Reset in Watchdog Timer Mode .....	364
<b>Section 13 Serial Communication Interface (SCI).....</b>		<b>365</b>
13.1	Overview.....	365
13.1.1	Features .....	365
13.1.2	Block Diagram.....	367
13.1.3	Pin Configuration .....	368
13.1.4	Register Configuration .....	369
13.2	Register Descriptions .....	370
13.2.1	Receive Shift Register (RSR) .....	370
13.2.2	Receive Data Register (RDR) .....	370
13.2.3	Transmit Shift Register (TSR).....	371
13.2.4	Transmit Data Register (TDR) .....	371
13.2.5	Serial Mode Register (SMR).....	372
13.2.6	Serial Control Register (SCR).....	375
13.2.7	Serial Status Register (SSR) .....	378
13.2.8	Bit Rate Register (BRR).....	382
13.2.9	Smart Card Mode Register (SCMR) .....	389
13.2.10	Module Stop Control Registers B and C (MSTPCRB, MSTPCRC).....	390
13.3	Operation .....	392
13.3.1	Overview .....	392
13.3.2	Operation in Asynchronous Mode.....	394
13.3.3	Multiprocessor Communication Function.....	405
13.3.4	Operation in Clocked Synchronous Mode .....	413
13.4	SCI Interrupts .....	421
13.5	Usage Notes .....	423
<b>Section 14 FLEX™ Roaming Decoder II.....</b>		<b>433</b>
14.1	Overview.....	433
14.1.1	Features .....	433
14.1.2	System Block Diagram.....	434
14.1.3	Functional Block Diagram.....	436
14.2	SPI Packets .....	437
14.2.1	Packet Communication Initiated by the Host.....	437
14.2.2	Packet Communication Initiated by the FLEX™ decoder II .....	438
14.2.3	Host-to-Decoder Packet Map .....	440

14.2.4	Decoder-to-Host Packet Map .....	442
14.3	Host-to-Decoder Packet Descriptions.....	442
14.3.1	Checksum Packet.....	442
14.3.2	Configuration Packet.....	445
14.3.3	Control Packet.....	448
14.3.4	All Frame Mode Packet.....	449
14.3.5	Operator Messaging Address Enable Packet.....	451
14.3.6	Roaming Control Packet .....	451
14.3.7	Timing Control Packet .....	454
14.3.8	Receiver Line Control Packet .....	455
14.3.9	Receiver Control Configuration Packets.....	455
14.3.10	Frame Assignment Packets .....	459
14.3.11	User Address Enable Packet .....	460
14.3.12	User Address Assignment Packets .....	461
14.4	Decoder-to-Host Packet Descriptions.....	462
14.4.1	Block Information Word Packet .....	463
14.4.2	Address Packet .....	464
14.4.3	Vector Packet.....	465
14.4.4	Message Packet .....	470
14.4.5	Roaming Status Packet.....	470
14.4.6	Receiver Shutdown Packet.....	473
14.4.7	Status Packet .....	474
14.4.8	Part ID Packet.....	476
14.5	Application Notes.....	478
14.5.1	Receiver Control .....	478
14.5.2	Message Building .....	481
14.5.3	Building a Fragmented Message.....	483
14.5.4	Operation of a Temporary Address.....	486
14.5.5	Using the Receiver Shutdown Packet .....	488
14.6	Timing Diagrams (Reference Data) .....	491
14.6.1	SPI Timing.....	491
14.6.2	Start-up Timing .....	493
14.6.3	Reset Timing .....	494
<b>Section 15 A/D Converter .....</b>		<b>495</b>
15.1	Overview.....	495
15.1.1	Features .....	495
15.1.2	Block Diagram.....	496
15.1.3	Pin Configuration .....	497
15.1.4	Register Configuration .....	498
15.2	Register Descriptions.....	499
15.2.1	A/D Data Registers A to D (ADDRA to ADDRD).....	499
15.2.2	A/D Control/Status Register (ADCSR).....	500



15.2.3	A/D Control Register (ADCR).....	502
15.2.4	Module Stop Control Register A (MSTPCRA).....	503
15.3	Interface to Bus Master.....	504
15.4	Operation .....	505
15.4.1	Single Mode (SCAN = 0).....	505
15.4.2	Scan Mode (SCAN = 1) .....	507
15.4.3	Input Sampling and A/D Conversion Time.....	509
15.4.4	External Trigger Input Timing .....	510
15.5	Interrupts.....	511
15.6	Usage Notes .....	511
<b>Section 16 RAM.....</b>		<b>517</b>
16.1	Overview.....	517
16.1.1	Block Diagram.....	517
16.1.2	Register Configuration .....	518
16.2	Register Descriptions .....	518
16.2.1	System Control Register (SYSCR) .....	518
16.3	Operation .....	519
16.4	Usage Note .....	519
<b>Section 17 ROM.....</b>		<b>521</b>
17.1	Overview.....	521
17.1.1	Block Diagram.....	521
17.1.2	Register Configuration .....	522
17.2	Register Descriptions .....	522
17.2.1	Mode Control Register (MDCR).....	522
17.3	Operation .....	522
17.4	Overview of Flash Memory.....	524
17.4.1	Features .....	524
17.4.2	Block Diagram.....	525
17.4.3	Mode Transitions.....	526
17.4.4	On-Board Programming Modes .....	527
17.4.5	Flash Memory Emulation in RAM.....	529
17.4.6	Differences between Boot Mode and User Program Mode.....	530
17.4.7	Block Configuration .....	531
17.5	Pin Configuration .....	532
17.6	Register Configuration .....	533
17.7	Register Descriptions .....	534
17.7.1	Flash Memory Control Register 1 (FLMCR1).....	534
17.7.2	Flash Memory Control Register 2 (FLMCR2).....	537
17.7.3	Erase Block Register 1 (EBR1).....	538
17.7.4	Erase Block Register 2 (EBR2).....	538
17.7.5	RAM Emulation Register (RAMER) .....	539

17.7.6	Flash Memory Power Control Register (FLPWCR)	540
17.7.7	Serial Control Register X (SCRX)	541
17.8	On-Board Programming Modes	542
17.8.1	Boot Mode	542
17.8.2	User Program Mode	547
17.9	Programming/Erasing Flash Memory	549
17.9.1	Program Mode	549
17.9.2	Program-Verify Mode	550
17.9.3	Erase Mode	552
17.9.4	Erase-Verify Mode	552
17.10	Protection	554
17.10.1	Hardware Protection	554
17.10.2	Software Protection	555
17.10.3	Error Protection	556
17.11	Flash Memory Emulation in RAM	558
17.12	Interrupt Handling when Programming/Erasing Flash Memory	560
17.13	Flash Memory Programmer Mode	560
17.13.1	Socket Adapter Pin Correspondence Diagram	561
17.13.2	Programmer Mode Operation	563
17.13.3	Memory Read Mode	564
17.13.4	Auto-Program Mode	567
17.13.5	Auto-Erase Mode	569
17.13.6	Status Read Mode	571
17.13.7	Status Polling	572
17.13.8	Programmer Mode Transition Time	572
17.13.9	Notes on Memory Programming	573
17.14	Flash Memory and Power-Down States	574
17.14.1	Note on Power-Down States	574
17.15	Flash Memory Programming and Erasing Precautions	575
<b>Section 18 Clock Pulse Generator</b>		<b>581</b>
18.1	Overview	581
18.1.1	Block Diagram	581
18.1.2	Register Configuration	582
18.2	Register Descriptions	582
18.2.1	System Clock Control Register (SCKCR)	582
18.2.2	Low-Power Control Register (LPWRCR)	583
18.3	System Clock Oscillator	587
18.3.1	Connecting a Crystal Resonator	587
18.3.2	External Clock Input	588
18.4	Duty Adjustment Circuit	592
18.5	Medium-Speed Clock Divider	592
18.6	Bus Master Clock Selection Circuit	592

18.7	Subclock Oscillator.....	592
18.8	Subclock Waveform Shaping Circuit.....	594
18.9	Note on Crystal Resonator.....	594
<b>Section 19 Power-Down Modes .....</b>		<b>595</b>
19.1	Overview.....	595
19.1.1	Register Configuration .....	599
19.2	Register Descriptions.....	599
19.2.1	Standby Control Register (SBYCR) .....	599
19.2.2	System Clock Control Register (SCKCR) .....	601
19.2.3	Low-Power Control Register (LPWRCR).....	602
19.2.4	Timer Control/Status Register (TCSR).....	604
19.2.5	Module Stop Control Register (MSTPCR).....	605
19.3	Medium-Speed Mode .....	606
19.4	Sleep Mode.....	607
19.4.1	Sleep Mode.....	607
19.4.2	Clearing Sleep Mode.....	607
19.5	Module Stop Mode .....	608
19.5.1	Module Stop Mode .....	608
19.5.2	Usage Note .....	609
19.6	Software Standby Mode .....	610
19.6.1	Software Standby Mode .....	610
19.6.2	Clearing Software Standby Mode .....	610
19.6.3	Setting Oscillation Stabilization Time after Clearing Software Standby Mode ..	611
19.6.4	Software Standby Mode Application Example .....	611
19.6.5	Usage Notes.....	612
19.7	Hardware Standby Mode .....	612
19.7.1	Hardware Standby Mode.....	612
19.7.2	Hardware Standby Mode Timing .....	613
19.8	Watch Mode .....	614
19.8.1	Watch Mode .....	614
19.8.2	Clearing Watch Mode .....	614
19.8.3	Usage Notes.....	615
19.9	Subsleep Mode .....	615
19.9.1	Subsleep Mode .....	615
19.9.2	Clearing Subsleep Mode .....	615
19.10	Subactive Mode .....	616
19.10.1	Subactive Mode.....	616
19.10.2	Clearing Subactive Mode .....	616
19.11	Direct Transition.....	617
19.11.1	Overview of Direct Transition.....	617
19.12	∅ Clock Output Disabling Function.....	617
19.13	Usage Notes.....	618

19.13.1 I/O Port Status .....	618
19.13.2 Current Dissipation during Oscillation Stabilization Wait Period .....	618
19.13.3 DTC Module Stop .....	618
19.13.4 On-Chip Supporting Module Interrupt .....	618
19.13.5 Writing to MSTPCR .....	618
19.13.6 Entering Subactive/Watch Mode and DTC Module Stop .....	619
<b>Section 20 Electrical Characteristics</b> .....	<b>621</b>
20.1 Power Supply Voltage and Operating Frequency Range .....	621
20.2 Electrical Characteristics .....	622
20.2.1 Absolute Maximum Ratings .....	622
20.2.2 DC Characteristics .....	623
20.2.3 AC Characteristics .....	627
20.2.4 A/D Conversion Characteristics .....	632
20.2.5 Flash Memory Characteristics .....	633
20.3 Operational Timing .....	635
20.3.1 Clock Timing .....	635
20.3.2 Control Signal Timing .....	636
20.3.3 Bus Timing .....	637
20.3.4 Timing of On-Chip Supporting Modules .....	642
<b>Appendix A Instruction Set</b> .....	<b>645</b>
A.1 Instruction List .....	645
A.2 Instruction Codes .....	669
A.3 Operation Code Map .....	683
A.4 Number of States Required for Instruction Execution .....	687
A.5 Bus States During Instruction Execution .....	701
A.6 Condition Code Modification .....	715
<b>Appendix B Internal I/O Register</b> .....	<b>721</b>
B.1 Addresses .....	721
B.2 Functions .....	727
<b>Appendix C I/O Port Block Diagrams</b> .....	<b>813</b>
C.1 Port 1 Block Diagrams .....	813
C.2 Port 3 Block Diagrams .....	816
C.3 Port 4 Block Diagram .....	820
C.4 Port 7 Block Diagrams .....	821
C.5 Port A Block Diagrams .....	825
C.6 Port B Block Diagram .....	826
C.7 Port C Block Diagram .....	827
C.8 Port D Block Diagram .....	828
C.9 Port E Block Diagram .....	829

C.10	Port F Block Diagrams .....	830
C.11	Port G Block Diagrams.....	836
Appendix D	Pin States .....	840
D.1	Port States in Each Processing State.....	840
Appendix E	Timing of Transition to and Recovery from Hardware Standby Mode .....	843
Appendix F	Product Code Lineup.....	844
Appendix G	Package Dimensions.....	845



# Section 1 Overview

## 1.1 Overview

The LSI is a microcomputer (MCUs: microcomputer units), built around the H8S/2000 CPU, employing Hitachi's proprietary architecture, and equipped with the on-chip peripheral functions necessary for system configuration.

The H8S/2000 CPU has an internal 32-bit architecture, is provided with sixteen 16-bit general registers and a concise, optimized instruction set designed for high-speed operation, and can address a 16-Mbyte linear address space. The instruction set is upward-compatible with H8/300 and H8/300H CPU instructions at the object-code level, facilitating migration from the H8/300, H8/300L, or H8/300H Series.

On-chip peripheral functions required for system configuration include data transfer controller (DTC) bus masters, ROM and RAM memory, 16-bit timer-pulse unit (TPU), 8-bit timer (TMR), watchdog timer (WDT), serial communication interface (SCI), A/D converter, FLEX™\*1 decoder II, and I/O ports.

The on-chip ROM is single-power-supply flash memory (F-ZTAT™\*2) with a capacity of 128 kbytes. ROM is connected to the CPU via a 16-bit data bus, enabling both byte and word data to be accessed in one state. Instruction fetching has been speeded up, and processing speed increased.

Four operating modes, modes 4 to 7, are provided, and there is a choice of single-chip mode or external expansion mode.

The features of the LSI are shown in table 1.1.

Notes: \*1 FLEX™ is a trademark of Motorola.

\*2 F-ZTAT™ is a trademark of Hitachi, Ltd.

**Table 1.1 Overview**

<b>Item</b>	<b>Specification</b>
CPU	<ul style="list-style-type: none"> <li>• General-register machine <ul style="list-style-type: none"> <li>— Sixteen 16-bit general registers (also usable as sixteen 8-bit registers or eight 32-bit registers)</li> </ul> </li> <li>• High-speed operation suitable for realtime control <ul style="list-style-type: none"> <li>— Maximum clock rate: 13.5 MHz</li> <li>— High-speed arithmetic operations (at 13.5 MHz operation) <ul style="list-style-type: none"> <li>8/16/32-bit register-register add/subtract: 74 ns</li> <li>16 × 16-bit register-register multiply: 1480 ns</li> <li>32 ÷ 16-bit register-register divide: 1480 ns</li> </ul> </li> </ul> </li> <li>• Instruction set suitable for high-speed operation <ul style="list-style-type: none"> <li>— Sixty-five basic instructions</li> <li>— 8/16/32-bit move/arithmetic and logic instructions</li> <li>— Unsigned/signed multiply and divide instructions</li> <li>— Powerful bit-manipulation instructions</li> </ul> </li> <li>• Two CPU operating modes <ul style="list-style-type: none"> <li>— Normal mode: 64-kbyte address space (not available in the LSI)</li> <li>— Advanced mode: 16-Mbyte address space</li> </ul> </li> </ul>
Bus controller	<ul style="list-style-type: none"> <li>• Address space divided into 8 areas, with bus specifications settable independently for each area</li> <li>• Chip select output possible for areas 0 to 3</li> <li>• Choice of 8-bit or 16-bit access space for each area</li> <li>• 2-state or 3-state access space can be designated for each area</li> <li>• Number of program wait states can be set for each area</li> <li>• Burst ROM directly connectable</li> <li>• External bus release function</li> </ul>
Data transfer controller (DTC)	<ul style="list-style-type: none"> <li>• Can be activated by internal interrupt or software</li> <li>• Multiple transfers or multiple types of transfer possible for one activation source</li> <li>• Transfer possible in repeat mode, block transfer mode, etc.</li> <li>• Request can be sent to CPU for interrupt that activated DTC</li> </ul>



<b>Item</b>	<b>Specification</b>
16-bit timer-pulse unit (TPU)	<ul style="list-style-type: none"> <li>• 3-channel 16-bit timer on-chip</li> <li>• Pulse I/O processing capability for up to 6 pins'</li> <li>• Automatic 2-phase encoder count capability</li> </ul>
8-bit timer (TMR) 2 channels	<ul style="list-style-type: none"> <li>• 8-bit up-counter</li> <li>• Two time constant registers</li> <li>• Two-channel connection possible</li> </ul>
Watchdog timer (WDT) × 2 channels	<ul style="list-style-type: none"> <li>• Watchdog timer or interval timer selectable</li> <li>• Can operate on subclock (1 channel only)</li> </ul>
Serial communication interface (SCI) × 3 channels	<ul style="list-style-type: none"> <li>• Asynchronous mode or synchronous mode selectable</li> <li>• Multiprocessor communication function</li> <li>• LSB first/MSB first selectable</li> <li>• SCI3 is dedicated to the FLEX™ decoder II interface</li> </ul>
A/D converter	<ul style="list-style-type: none"> <li>• Resolution: 10 bits</li> <li>• Input: 8 channels</li> <li>• 9.9 μs minimum conversion time (at 13.5 MHz operation)</li> <li>• Single or scan mode selectable</li> <li>• Sample and hold circuit</li> <li>• A/D conversion can be activated by external trigger or timer trigger</li> </ul>
FLEX™ decoder II	<p>On-chip FLEX™ decoder II</p> <ul style="list-style-type: none"> <li>• Conforms to FLEX™ protocol revision 1.9</li> <li>• Decoding capability: 1600, 3200, 6400 bits/second</li> <li>• Decoding phase: Any-phase, single-phase</li> </ul>
I/O ports	<ul style="list-style-type: none"> <li>• 60 I/O pins, 8 input-only pins</li> </ul>
Memory	<ul style="list-style-type: none"> <li>• Flash memory</li> <li>• High-speed static RAM</li> </ul>

<b>Product Name</b>	<b>ROM</b>	<b>RAM</b>
H8S/2277, H8S/2277R	128 kbytes	16 kbytes

Item	Specification																																
Interrupt controller	<ul style="list-style-type: none"> <li>• Nine external interrupt pins (NMI, <math>\overline{\text{IRQ0}}</math> to <math>\overline{\text{IRQ7}}</math>)</li> <li>• <math>\overline{\text{IRQ6}}</math> is a dedicated interrupt for the FLEX™ decoder II</li> <li>• 36 internal interrupt sources</li> <li>• Eight priority levels settable</li> </ul>																																
PC break controller	<ul style="list-style-type: none"> <li>• Supports debugging functions by means of PC break interrupts</li> <li>• Two break channels</li> </ul>																																
Power-down state	<ul style="list-style-type: none"> <li>• Medium-speed mode</li> <li>• Sleep mode</li> <li>• Module stop mode</li> <li>• Software standby mode</li> <li>• Hardware standby mode</li> <li>• Subclock operation (subactive mode, subsleep mode, watch mode)</li> </ul>																																
Operating modes	Four MCU operating modes																																
	<table border="1"> <thead> <tr> <th rowspan="2">Mode</th> <th rowspan="2">CPU Operating Mode</th> <th rowspan="2">Description</th> <th rowspan="2">On-Chip ROM</th> <th colspan="2">External Data Bus</th> </tr> <tr> <th>Initial Value</th> <th>Maximum Value</th> </tr> </thead> <tbody> <tr> <td>4</td> <td>Advanced</td> <td>On-chip ROM disabled expansion mode</td> <td>Disabled</td> <td>16 bits</td> <td>16 bits</td> </tr> <tr> <td>5</td> <td></td> <td>On-chip ROM disabled expansion mode</td> <td>Disabled</td> <td>8 bits</td> <td>16 bits</td> </tr> <tr> <td>6</td> <td></td> <td>On-chip ROM enabled expansion mode</td> <td>Enabled</td> <td>8 bits</td> <td>16 bits</td> </tr> <tr> <td>7</td> <td></td> <td>Single-chip mode</td> <td>Enabled</td> <td>—</td> <td></td> </tr> </tbody> </table>	Mode	CPU Operating Mode	Description	On-Chip ROM	External Data Bus		Initial Value	Maximum Value	4	Advanced	On-chip ROM disabled expansion mode	Disabled	16 bits	16 bits	5		On-chip ROM disabled expansion mode	Disabled	8 bits	16 bits	6		On-chip ROM enabled expansion mode	Enabled	8 bits	16 bits	7		Single-chip mode	Enabled	—	
Mode	CPU Operating Mode					Description	On-Chip ROM	External Data Bus																									
		Initial Value	Maximum Value																														
4	Advanced	On-chip ROM disabled expansion mode	Disabled	16 bits	16 bits																												
5		On-chip ROM disabled expansion mode	Disabled	8 bits	16 bits																												
6		On-chip ROM enabled expansion mode	Enabled	8 bits	16 bits																												
7		Single-chip mode	Enabled	—																													
Clock pulse generator	<ul style="list-style-type: none"> <li>• Two on chip clock pulse generators <ul style="list-style-type: none"> <li>— System clock pulse generator: 2 to 13.5 MHz</li> <li>Built-in duty correction circuit</li> <li>— Subclock pulse generator: 76.8 kHz, 160 kHz</li> </ul> </li> </ul>																																
Packages	100-pin plastic TQFP (TFP-100B, TFP-100G)																																

<b>Item</b>	<b>Specification</b>			
Product lineup	<b>Model Name</b>			
	<b>Specification</b>	<b>F-ZTAT Version</b>	<b>ROM/RAM (Bytes)</b>	<b>Packages</b>
	Non-roaming	HD64F2277	128 k/16 k	TFP-100B
Roaming	HD64F2277R	128 k/16 k	TFP-100G	

# 1.2 Internal Block Diagrams

Figure 1.1 shows internal block diagrams.

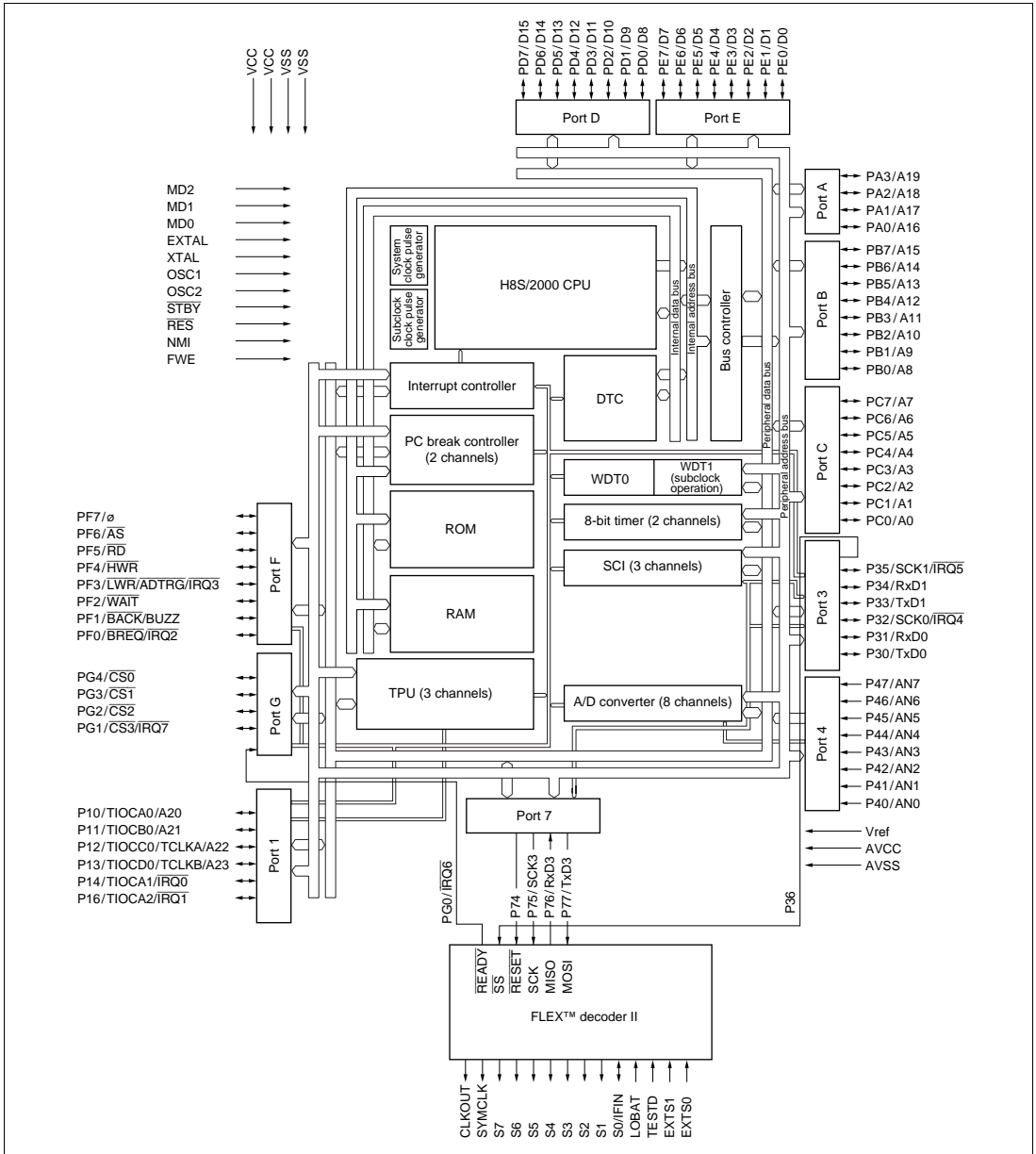
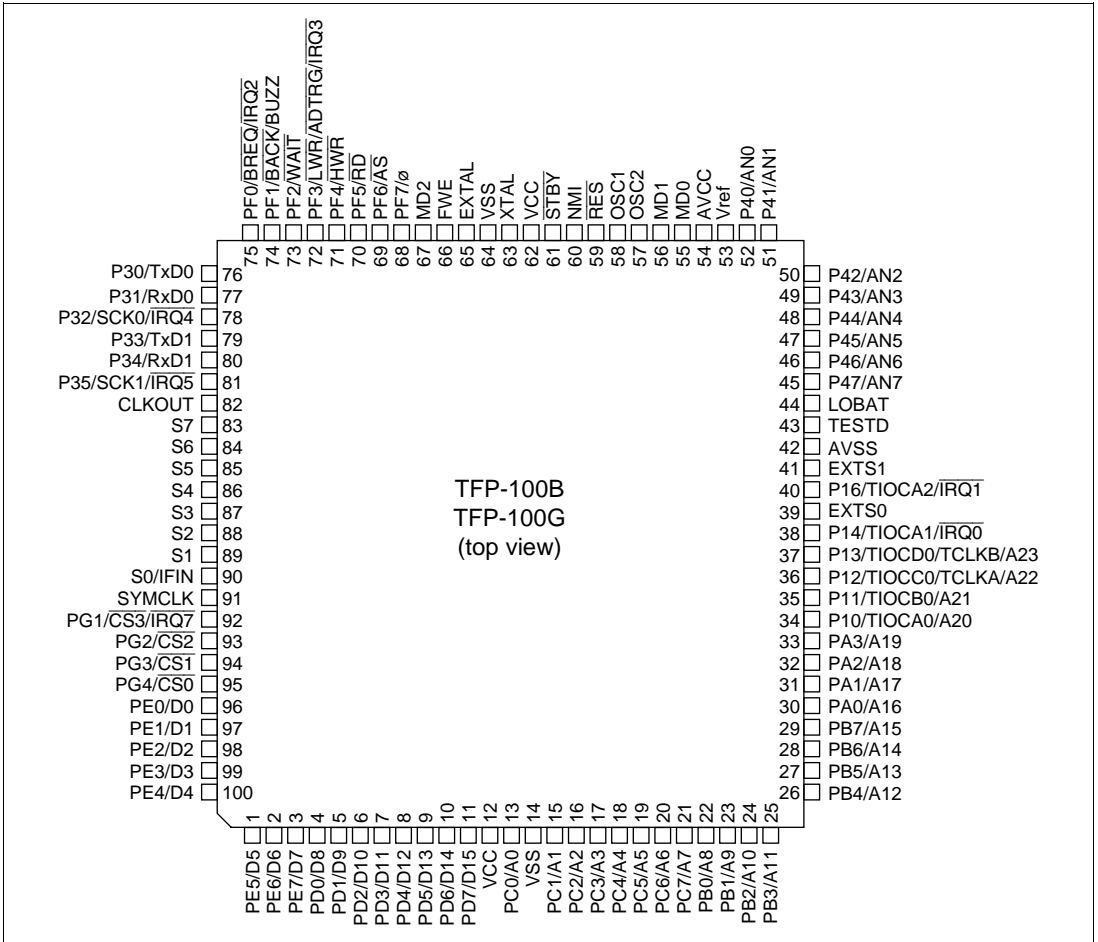


Figure 1.1 H8S/2276 Series Internal Block Diagram

# 1.3 Pin Description

## 1.3.1 Pin Arrangements

Figure 1.2 shows the pin arrangement of the H8S/2276 Series.



**Figure 1.2 H8S/2276 Series Pin Arrangement (TFP-100B, TFP-100G: Top View)**

### 1.3.2 Pin Functions in Each Operating Mode

Table 1.2 shows the pin functions in each of the operating modes.

**Table 1.2 Pin Functions in Each Operating Mode**

Pin No.	Pin Name				
	Mode 4	Mode 5	Mode 6	Mode 7	Flash Memory Programmer Mode
TFP-100B TFP-100G					
1	PE5/D5	PE5/D5	PE5/D5	PE5	$\overline{OE}$
2	PE6/D6	PE6/D6	PE6/D6	PE6	$\overline{WE}$
3	PE7/D7	PE7/D7	PE7/D7	PE7	$\overline{CE}$
4	D8	D8	D8	PD0	D0
5	D9	D9	D9	PD1	D1
6	D10	D10	D10	PD2	D2
7	D11	D11	D11	PD3	D3
8	D12	D12	D12	PD4	D4
9	D13	D13	D13	PD5	D5
10	D14	D14	D14	PD6	D6
11	D15	D15	D15	PD7	D7
12	VCC	VCC	VCC	VCC	VCC
13	A0	A0	PC0/A0	PC0	A0
14	VSS	VSS	VSS	VSS	VSS
15	A1	A1	PC1/A1	PC1	A1
16	A2	A2	PC2/A2	PC2	A2
17	A3	A3	PC3/A3	PC3	A3
18	A4	A4	PC4/A4	PC4	A4
19	A5	A5	PC5/A5	PC5	A5
20	A6	A6	PC6/A6	PC6	A6
21	A7	A7	PC7/A7	PC7	A7
22	PB0/A8	PB0/A8	PB0/A8	PB0	A8
23	PB1/A9	PB1/A9	PB1/A9	PB1	A9
24	PB2/A10	PB2/A10	PB2/A10	PB2	A10
25	PB3/A11	PB3/A11	PB3/A11	PB3	A11
26	PB4/A12	PB4/A12	PB4/A12	PB4	A12
27	PB5/A13	PB5/A13	PB5/A13	PB5	A13

Pin No.	Pin Name				Flash Memory Programmer Mode
	Mode 4	Mode 5	Mode 6	Mode 7	
TFP-100B TFP-100G					
28	PB6/A14	PB6/A14	PB6/A14	PB6	A14
29	PB7/A15	PB7/A15	PB7/A15	PB7	A15
30	PA0/A16	PA0/A16	PA0/A16	PA0	A16
31	PA1/A17	PA1/A17	PA1/A17	PA1	A17
32	PA2/A18	PA2/A18	PA2/A18	PA2	A18
33	PA3/A19	PA3/A19	PA3/A19	PA3	NC
34	P10/TIOCA0/ A20	P10/TIOCA0/ A20	P10/TIOCA0/ A20	P10/TIOCA0	NC
35	P11/TIOCB0/ A21	P11/TIOCB0/ A21	P11/TIOCB0/ A21	P11/TIOCB0	NC
36	P12/TIOCC0/ TCLKA/A22	P12/TIOCC0/ TCLKA/A22	P12/TIOCC0/ TCLKA/A22	P12/TIOCC0/ TCLKA	NC
37	P13/TIOCD0/ TCLKB/A23	P13/TIOCD0/ TCLKB/A23	P13/TIOCD0/ TCLKB/A23	P13/TIOCD0/ TCLKB	NC
38	P14/TIOCA1/ IRQ0	P14/TIOCA1/ IRQ0	P14/TIOCA1/ IRQ0	P14/TIOCA1/ IRQ0	VSS
39	EXTS0	EXTS0	EXTS0	EXTS0	NC
40	P16/TIOCA2/ IRQ1	P16/TIOCA2/ IRQ1	P16/TIOCA2/ IRQ1	P16/TIOCA2/ IRQ1	VSS
41	EXTS1	EXTS1	EXTS1	EXTS1	NC
42	AVSS	AVSS	AVSS	AVSS	VSS
43	TESTD	TESTD	TESTD	TESTD	NC
44	LOBAT	LOBAT	LOBAT	LOBAT	NC
45	P47/AN7	P47/AN7	P47/AN7	P47/AN7	NC
46	P46/AN6	P46/AN6	P46/AN6	P46/AN6	NC
47	P45/AN5	P45/AN5	P45/AN5	P45/AN5	NC
48	P44/AN4	P44/AN4	P44/AN4	P44/AN4	NC
49	P43/AN3	P43/AN3	P43/AN3	P43/AN3	NC
50	P42/AN2	P42/AN2	P42/AN2	P42/AN2	NC
51	P41/AN1	P41/AN1	P41/AN1	P41/AN1	NC
52	P40/AN0	P40/AN0	P40/AN0	P40/AN0	NC
53	Vref	Vref	Vref	Vref	VCC
54	AVCC	AVCC	AVCC	AVCC	VCC

Pin No.	Pin Name				
TFP-100B TFP-100G	Mode 4	Mode 5	Mode 6	Mode 7	Flash Memory Programmer Mode
55	MD0	MD0	MD0	MD0	VSS
56	MD1	MD1	MD1	MD1	VSS
57	OSC2	OSC2	OSC2	OSC2	NC
58	OSC1	OSC1	OSC1	OSC1	VCC
59	$\overline{\text{RES}}$	$\overline{\text{RES}}$	$\overline{\text{RES}}$	$\overline{\text{RES}}$	$\overline{\text{RES}}$
60	NMI	NMI	NMI	NMI	VCC
61	$\overline{\text{STBY}}$	$\overline{\text{STBY}}$	$\overline{\text{STBY}}$	$\overline{\text{STBY}}$	VCC
62	VCC	VCC	VCC	VCC	VCC
63	XTAL	XTAL	XTAL	XTAL	XTAL
64	VSS	VSS	VSS	VSS	VSS
65	EXTAL	EXTAL	EXTAL	EXTAL	EXTAL
66	FWE	FWE	FWE	FWE	FWE
67	MD2	MD2	MD2	MD2	VSS
68	PF7/ $\emptyset$	PF7/ $\emptyset$	PF7/ $\emptyset$	PF7/ $\emptyset$	NC
69	$\overline{\text{AS}}$	$\overline{\text{AS}}$	$\overline{\text{AS}}$	PF6	NC
70	$\overline{\text{RD}}$	$\overline{\text{RD}}$	$\overline{\text{RD}}$	PF5	NC
71	$\overline{\text{HWR}}$	$\overline{\text{HWR}}$	$\overline{\text{HWR}}$	PF4	NC
72	PF3/ $\overline{\text{LWR}}$ / $\overline{\text{ADTRG}}/\overline{\text{IRQ3}}$	PF3/ $\overline{\text{LWR}}$ / $\overline{\text{ADTRG}}/\overline{\text{IRQ3}}$	PF3/ $\overline{\text{LWR}}$ / $\overline{\text{ADTRG}}/\overline{\text{IRQ3}}$	PF3/ $\overline{\text{ADTRG}}/\overline{\text{IRQ3}}$	VCC
73	PF2/ $\overline{\text{WAIT}}$	PF2/ $\overline{\text{WAIT}}$	PF2/ $\overline{\text{WAIT}}$	PF2	NC
74	PF1/ $\overline{\text{BACK}}$ / BUZZ	PF1/ $\overline{\text{BACK}}$ / BUZZ	PF1/ $\overline{\text{BACK}}$ / BUZZ	PF1/BUZZ	NC
75	PF0/ $\overline{\text{BREQ}}$ / $\overline{\text{IRQ2}}$	PF0/ $\overline{\text{BREQ}}$ / $\overline{\text{IRQ2}}$	PF0/ $\overline{\text{BREQ}}$ / $\overline{\text{IRQ2}}$	PF0/ $\overline{\text{IRQ2}}$	VCC
76	P30/TxD0	P30/TxD0	P30/TxD0	P30/TxD0	NC
77	P31/RxD1	P31/RxD1	P31/RxD1	P31/RxD1	NC
78	P32/SCK0/ $\overline{\text{IRQ4}}$	P32/SCK0/ $\overline{\text{RQ4}}$	P32/SCK0/ $\overline{\text{IRQ4}}$	P32/SCK0/ $\overline{\text{IRQ4}}$	NC
79	P33/TxD1	P33/TxD1	P33/TxD1	P33/TxD1	NC
80	P34/RxD1	P34/RxD1	P34/RxD1	P34/RxD1	NC



Pin No.	Pin Name				Flash Memory Programmer Mode
	Mode 4	Mode 5	Mode 6	Mode 7	
TFP-100B TFP-100G					
81	P35/SCK1/ IRQ5	P35/SCK1/ IRQ5	P35/SCK1/ IRQ5	P35/SCK1/ IRQ5	NC
82	CLKOUT	CLKOUT	CLKOUT	CLKOUT	NC
83	S7	S7	S7	S7	NC
84	S6	S6	S6	S6	NC
85	S5	S5	S5	S5	NC
86	S4	S4	S4	S4	NC
87	S3	S3	S3	S3	NC
88	S2	S2	S2	S2	NC
89	S1	S1	S1	S1	NC
90	S0/IFIN	S0/IFIN	S0/IFIN	S0/IFIN	NC
91	SYMCLK	SYMCLK	SYMCLK	SYMCLK	NC
92	PG1/ $\overline{\text{CS3}}$ / IRQ7	PG1/ $\overline{\text{CS3}}$ / IRQ7	PG1/ $\overline{\text{CS3}}$ / IRQ7	PG1/IRQ7	NC
93	PG2/ $\overline{\text{CS2}}$	PG2/ $\overline{\text{CS2}}$	PG2/ $\overline{\text{CS2}}$	PG2	NC
94	PG3/ $\overline{\text{CS1}}$	PG3/ $\overline{\text{CS1}}$	PG3/ $\overline{\text{CS1}}$	PG3	NC
95	PG4/ $\overline{\text{CS0}}$	PG4/ $\overline{\text{CS0}}$	PG4/ $\overline{\text{CS0}}$	PG4	NC
96	PE0/D0	PE0/D0	PE0/D0	PE0	NC
97	PE1/D1	PE1/D1	PE1/D1	PE1	NC
98	PE2/D2	PE2/D2	PE2/D2	PE2	NC
99	PE3/D3	PE3/D3	PE3/D3	PE3	VCC
100	PE4/D4	PE4/D4	PE4/D4	PE4	VSS

### 1.3.3 Pin Functions

Table 1.3 outlines the pin functions.

**Table 1.3 Pin Functions**

Type	Symbol	I/O	Name and Function																													
Power	VCC	Input	<b>Power supply:</b> For connection to the power supply. All $V_{CC}$ pins should be connected to the system power supply.																													
	VSS	Input	<b>Ground:</b> For connection to ground (0 V). All $V_{SS}$ pins should be connected to the system power supply (0 V).																													
Clock	XTAL	Input	<b>Crystal:</b> Connects to a crystal oscillator. See section 18, Clock Pulse Generator, for typical connection diagrams for a crystal oscillator and external clock input.																													
	EXTAL	Input	<b>External clock:</b> Connects to a crystal oscillator. The EXTAL pin can also input an external clock. See section 18, Clock Pulse Generator, for typical connection diagrams for a crystal oscillator and external clock input.																													
	OSC1	Input	<b>Subclock:</b> Connects to a 76.8 kHz or 160 kHz crystal oscillator. See section 18, Clock Pulse Generator, for typical connection diagrams for a crystal oscillator.																													
	OSC2	Input	<b>Subclock:</b> Connects to a 76.8 kHz or 160 kHz crystal oscillator. See section 18, Clock Pulse Generator, for typical connection diagrams for a crystal oscillator.																													
	∅	Output	<b>System clock:</b> Supplies the system clock to an external device.																													
Operating mode control	MD2 to MD0	Input	<p><b>Mode pins:</b> These pins set the operating mode. The relation between the settings of pins MD2 to MD0 and the operating mode is shown below. These pins should not be changed while the LSI is operating.</p> <p>Except when changing the mode, the levels of mode pins MD2 to MD0 must be fixed by pulling the pins up or down.</p> <table border="1"> <thead> <tr> <th>MD2</th> <th>MD1</th> <th>MD0</th> <th>Operating Mode</th> </tr> </thead> <tbody> <tr> <td rowspan="6">0</td> <td rowspan="2">0</td> <td>0</td> <td>—</td> </tr> <tr> <td>1</td> <td>—</td> </tr> <tr> <td rowspan="2">1</td> <td>0</td> <td>—</td> </tr> <tr> <td>1</td> <td>—</td> </tr> <tr> <td rowspan="2">1</td> <td>0</td> <td>0</td> <td>Mode 4</td> </tr> <tr> <td>1</td> <td>1</td> <td>Mode 5</td> </tr> <tr> <td rowspan="2">1</td> <td>0</td> <td>0</td> <td>Mode 6</td> </tr> <tr> <td>1</td> <td>1</td> <td>Mode 7</td> </tr> </tbody> </table>	MD2	MD1	MD0	Operating Mode	0	0	0	—	1	—	1	0	—	1	—	1	0	0	Mode 4	1	1	Mode 5	1	0	0	Mode 6	1	1	Mode 7
			MD2	MD1	MD0	Operating Mode																										
0	0	0	—																													
		1	—																													
	1	0	—																													
		1	—																													
	1	0	0	Mode 4																												
		1	1	Mode 5																												
1	0	0	Mode 6																													
	1	1	Mode 7																													

Type	Symbol	I/O	Name and Function
System control	$\overline{\text{RES}}$	Input	<b>Reset input:</b> When this pin is driven low, the chip enters the power-on reset state.
	$\overline{\text{STBY}}$	Input	<b>Standby:</b> When this pin is driven low, a transition is made to hardware standby mode.
	$\overline{\text{BREQ}}$	Input	<b>Bus request:</b> Used by an external bus master to issue a bus request to the LSI.
	$\overline{\text{BACK}}$	Output	<b>Bus request acknowledge:</b> Indicates that the bus has been released to an external bus master.
	FWE	Input	<b>Flash write enable:</b> Enables or disables flash memory programming.
Interrupts	NMI	Input	<b>Nonmaskable interrupt:</b> Requests a nonmaskable interrupt. When this pin is not used, it should be fixed high.
	$\overline{\text{IRQ7}}$ to $\overline{\text{IRQ0}}$	Input	<b>Interrupt request 7 to 0:</b> These pins request a maskable interrupt. $\overline{\text{IRQ6}}$ is a dedicated interrupt for the FLEX™ decoder II.
Address bus	A23 to A0	Output	<b>Address bus:</b> These pins output an address.
Data bus	D15 to D0	I/O	<b>Data bus:</b> These pins constitute a bidirectional data bus.
Bus control	$\overline{\text{CS3}}$ to $\overline{\text{CS0}}$	Output	<b>Chip select:</b> Signals for selecting areas 3 to 0.
	$\overline{\text{AS}}$	Output	<b>Address strobe:</b> When this pin is low, it indicates that address output on the address bus is enabled.
	$\overline{\text{RD}}$	Output	<b>Read:</b> When this pin is low, it indicates that the external address space can be read.
	$\overline{\text{HWR}}$	Output	<b>High write:</b> A strobe signal that writes to external space and indicates that the upper half (D15 to D8) of the data bus is enabled.
	$\overline{\text{LWR}}$	Output	<b>Low write:</b> A strobe signal that writes to external space and indicates that the lower half (D7 to D0) of the data bus is enabled.
	$\overline{\text{WAIT}}$	Input	<b>Wait:</b> Requests insertion of a wait state in the bus cycle when accessing external 3-state address space.

Type	Symbol	I/O	Name and Function
16-bit timer-pulse unit (TPU)	TCLKB, TCLKA	Input	<b>Clock input B and A:</b> These pins input an external clock.
	TIOCA0, TIOCB0, TIOCC0, TIOCD0	I/O	<b>Input capture/output compare match A0 to D0:</b> The TGR0A to TGR0D input capture input or output compare output, or PWM output pins.
	TIOCA1	I/O	<b>Input capture/output compare match A1:</b> The TGR1A input capture input or output compare output, or PWM output pin.
	TIOCA2	I/O	<b>Input capture/output compare match A2:</b> The TGR2A input capture input or output compare output, or PWM output pin.
Watchdog timer (WDT)	BUZZ	Output	<b>BUZZ output:</b> Outputs pulses scaled by the watchdog timer.
Serial communication interface (SCI)	TxD3, TxD1, TxD0	Output	<b>Transmit data:</b> Data output pins. TxD3 is an internal dedicated pin for the FLEX™ decoder II interface.
	RxD3, RxD1, RxD0	Input	<b>Receive data:</b> Data input pins. RxD3 is an internal dedicated pin for the FLEX™ decoder II interface.
	SCK3	Output	<b>Serial clock:</b> Clock I/O pins.
	SCK1, SCK0	I/O	SCK3 is an internal dedicated pin for the FLEX™ decoder II interface.
A/D converter	AN7 to AN0	Input	<b>Analog 7 to 0:</b> Analog input pins.
	ADTRG	Input	<b>A/D conversion external trigger input:</b> Pin for input of an external trigger to start A/D conversion.
	AV <sub>CC</sub>	Input	This is the power supply pin for the A/D converter. When the A/D converter is not used, this pin should be connected to the system power supply (+3 V).
	AV <sub>SS</sub>	Input	This is the ground pin for the A/D converter. This pin should be connected to the system power supply (0 V).
	V <sub>ref</sub>	Input	This is the reference voltage input pin for the A/D converter. When the A/D converter is not used, this pin should be connected to the system power supply (+3 V).

Type	Symbol	I/O	Name and Function
I/O ports	P16, P14 to P10	I/O	<b>Port 1:</b> A 6-bit I/O port. Input or output can be designated for each bit by means of the port 1 data direction register (P1DDR).
	P35 to P30	I/O	<b>Port 3:</b> A 6-bit I/O port. Input or output can be designated for each bit by means of the port 3 data direction register (P3DDR).
	P47 to P40	Input	<b>Port 4:</b> An 8-bit input port.
	PA3 to PA0	I/O	<b>Port A:</b> A 4-bit I/O port. Input or output can be designated for each bit by means of the port A data direction register (PADDDR).
	PB7 to PB0	I/O	<b>Port B:</b> An 8-bit I/O port. Input or output can be designated for each bit by means of the port B data direction register (PBDDR).
	PC7 to PC0	I/O	<b>Port C:</b> An 8-bit I/O port. Input or output can be designated for each bit by means of the port C data direction register (PCDDR).
	PD7 to PD0	I/O	<b>Port D:</b> An 8-bit I/O port. Input or output can be designated for each bit by means of the port D data direction register (PDDDR).
	PE7 to PE0	I/O	<b>Port E:</b> An 8-bit I/O port. Input or output can be designated for each bit by means of the port E data direction register (PEDDDR).
	PF7 to PF0	I/O	<b>Port F:</b> An 8-bit I/O port. Input or output can be designated for each bit by means of the port F data direction register (PFDDR).
Internal I/O ports (dedicated ports for the FLEX™ decoder II interface)	PG4 to PG1	I/O	<b>Port G:</b> A 4-bit I/O port. Input or output can be designated for each bit by means of the port G data direction register (PGDDR).
	P36	I/O	<b>Port 3:</b> A 1-bit I/O port. Input or output can be designated for each bit by means of the port 3 data direction register (P3DDR).
	P77 to P74	I/O	<b>Port 7:</b> A 4-bit I/O port. Input or output can be designated for each bit by means of the port 7 data direction register (P7DDR).
	PG0	Input	<b>Port G:</b> A 1-bit input port.

Type	Symbol	I/O	Name and Function
FLEX™ decoder II	$\overline{\text{RESET}}$	Input	<b>Decoder reset:</b> A reset is executed when this pin goes low.
	EXTS1	Input	<b>Decode symbol input:</b> MSb of the symbol currently being decoded.
	EXTS0	Input	<b>Decode symbol input:</b> LSb of the symbol currently being decoded.
	LOBAT	Input	<b>Voltage drop detection input:</b> Input pin for the voltage drop detection signal.
	$\overline{\text{SS}}$	Input	<b>SPI mode select:</b> Slave mode is selected when this pin goes low.
	SCK	Input	<b>SPI clock input:</b> SPI clock input.
	MOSI	Input	<b>SPI receive data input:</b> SPI data input.
	MISO	Output	<b>SPI transmit data output:</b> SPI data output.
	$\overline{\text{READY}}$	Output	<b>Ready pin:</b> Goes low when the SPI is ready to transmit/receive.
	CLKOUT	Output	<b>Clock output:</b> 38.4 kHz or 40 kHz clock output (derived from on-chip crystal oscillator).
	SYMCLK	Output	<b>Symbol clock output:</b> Recovered symbol clock pin.
	S0	Output	<b>Receiver control output:</b> Receiver control signal output pin (when using external demodulator).
	S1 to S7	Output	<b>Receiver control output:</b> Three-state receiver control signal output.
IFIN	Input	<b>IF signal input:</b> Limited IF signal input pin (when using internal demodulator).	

# Section 2 CPU

## 2.1 Overview

The H8S/2000 CPU is a high-speed central processing unit with an internal 32-bit architecture that is upward-compatible with the H8/300 and H8/300H CPUs. The H8S/2000 CPU has sixteen 16-bit general registers, can address a 16-Mbyte (architecturally 4-Gbyte) linear address space, and is ideal for realtime control.

### 2.1.1 Features

The H8S/2000 CPU has the following features.

- Upward-compatible with H8/300 and H8/300H CPUs
  - Can execute H8/300 and H8/300H object programs
- General-register architecture
  - Sixteen 16-bit general registers (also usable as sixteen 8-bit registers or eight 32-bit registers)
- Sixty-five basic instructions
  - 8/16/32-bit arithmetic and logic instructions
  - Multiply and divide instructions
  - Powerful bit-manipulation instructions
- Eight addressing modes
  - Register direct [Rn]
  - Register indirect [@ERn]
  - Register indirect with displacement [@(d:16,ERn) or @(d:32,ERn)]
  - Register indirect with post-increment or pre-decrement [@ERn+ or @-ERn]
  - Absolute address [@aa:8, @aa:16, @aa:24, or @aa:32]
  - Immediate [#xx:8, #xx:16, or #xx:32]
  - Program-counter relative [@(d:8,PC) or @(d:16,PC)]
  - Memory indirect [@@aa:8]
- 16-Mbyte address space
  - Program: 16 Mbytes
  - Data: 16 Mbytes (4 Gbytes architecturally)

- High-speed operation
  - All frequently-used instructions execute in one or two states
  - Maximum clock rate: 13.5 MHz
  - 8/16/32-bit register-register add/subtract: 74 ns (at 13.5 MHz operation)
  - 8 × 8-bit register-register multiply: 888 ns (at 13.5 MHz operation)
  - 16 ÷ 8-bit register-register divide: 888 ns (at 13.5 MHz operation)
  - 16 × 16-bit register-register multiply: 1480 ns (at 13.5 MHz operation)
  - 32 ÷ 16-bit register-register divide: 1480 ns (at 13.5 MHz operation)
- Two CPU operating modes
  - Normal mode\*
  - Advanced mode
 Note: \* Not available in the LSI.
- Power-down state
  - Transition to power-down state by SLEEP instruction
  - CPU clock speed selection

### 2.1.2 Differences between H8S/2600 CPU and H8S/2000 CPU

The differences between the H8S/2600 CPU and the H8S/2000 CPU are as shown below.

- Register configuration
  - The MAC register is supported only by the H8S/2600 CPU.
- Basic instructions
  - The four instructions MAC, CLRMAC, LDMAC, and STMAC are supported only by the H8S/2600 CPU.
- Number of execution states
  - The number of execution states of the MULXU and MULXS instructions.

Instruction	Mnemonic	Internal Operation	
		H8S/2600	H8S/2000
MULXU	MULXU.B Rs, Rd	3	12
	MULXU.W Rs, ERd	4	20
MULXS	MULXS.B Rs, Rd	4	13
	MULXS.W Rs, ERd	5	21



There are also differences in the address space, CCR and EXR register functions, power-down state, etc., depending on the product.

### 2.1.3 Differences from H8/300 CPU

In comparison to the H8/300 CPU, the H8S/2000 CPU has the following enhancements.

- More general registers and control registers
  - Eight 16-bit expanded registers, plus one 8-bit and two 32-bit control registers, have been added.
- Expanded address space
  - Normal mode\* supports the same 64-kbyte address space as the H8/300 CPU.
  - Advanced mode supports a maximum 16-Mbyte address space.

Note: \* Not available in the LSI.

- Enhanced addressing
  - The addressing modes have been enhanced to make effective use of the 16-Mbyte address space.
- Enhanced instructions
  - Addressing modes of bit-manipulation instructions have been enhanced.
  - Signed multiply and divide instructions have been added.
  - Two-bit shift instructions have been added.
  - Instructions for saving and restoring multiple registers have been added.
  - A test and set instruction has been added.
- Higher speed
  - Basic instructions execute twice as fast.

### 2.1.4 Differences from H8/300H CPU

In comparison to the H8/300H CPU, the H8S/2000 CPU has the following enhancements.

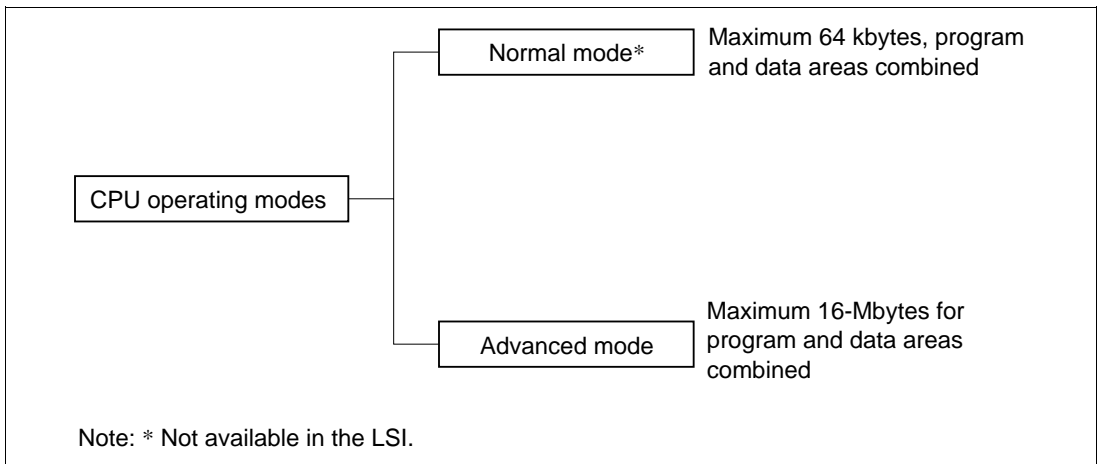
- Additional control register
  - One 8-bit and two 32-bit control registers have been added.
- Enhanced instructions
  - Addressing modes of bit-manipulation instructions have been enhanced.
  - Two-bit shift instructions have been added.
  - Instructions for saving and restoring multiple registers have been added.
  - A test and set instruction has been added.

- Higher speed
  - Basic instructions execute twice as fast.

## 2.2 CPU Operating Modes

The H8S/2000 CPU has two operating modes: normal\* and advanced. Normal mode supports a maximum 64-kbyte address space. Advanced mode supports a maximum 16-Mbyte total address space (architecturally a maximum 16-Mbyte program area and a maximum of 4 Gbytes for program and data areas combined). The mode is selected by the mode pins of the microcontroller.

Note: \* Not available in the LSI.



**Figure 2.1 CPU Operating Modes**

### (1) Normal Mode (not available in the LSI)

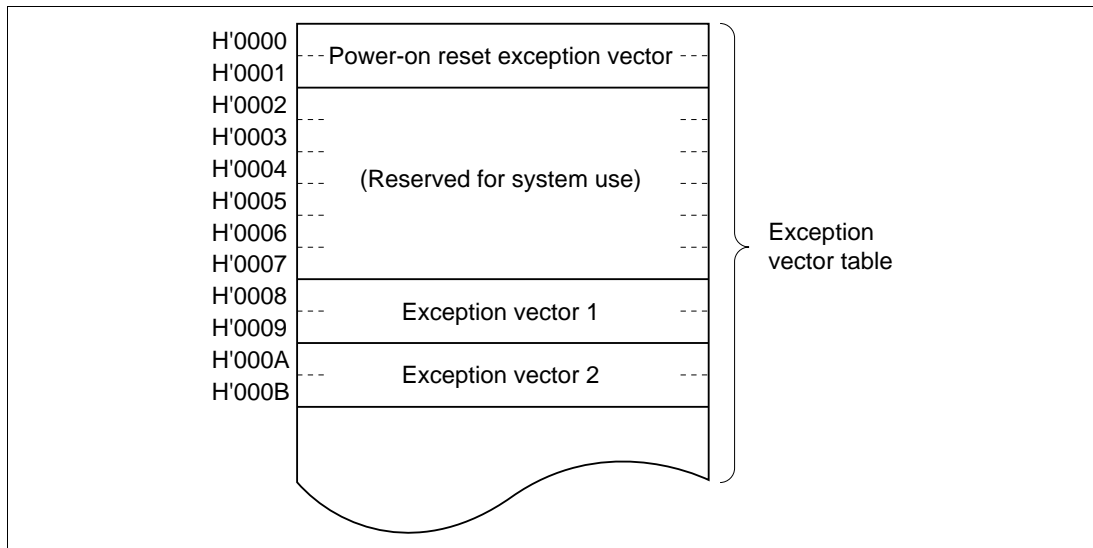
The exception vector table and stack have the same structure as in the H8/300 CPU.

**Address Space:** A maximum address space of 64 kbytes can be accessed.

**Extended Registers (En):** The extended registers (E0 to E7) can be used as 16-bit registers, or as the upper 16-bit segments of 32-bit registers. When En is used as a 16-bit register it can contain any value, even when the corresponding general register (Rn) is used as an address register. If the general register is referenced in the register indirect addressing mode with pre-decrement (@-Rn) or post-increment (@Rn+) and a carry or borrow occurs, however, the value in the corresponding extended register (En) will be affected.

**Instruction Set:** All instructions and addressing modes can be used. Only the lower 16 bits of effective addresses (EA) are valid.

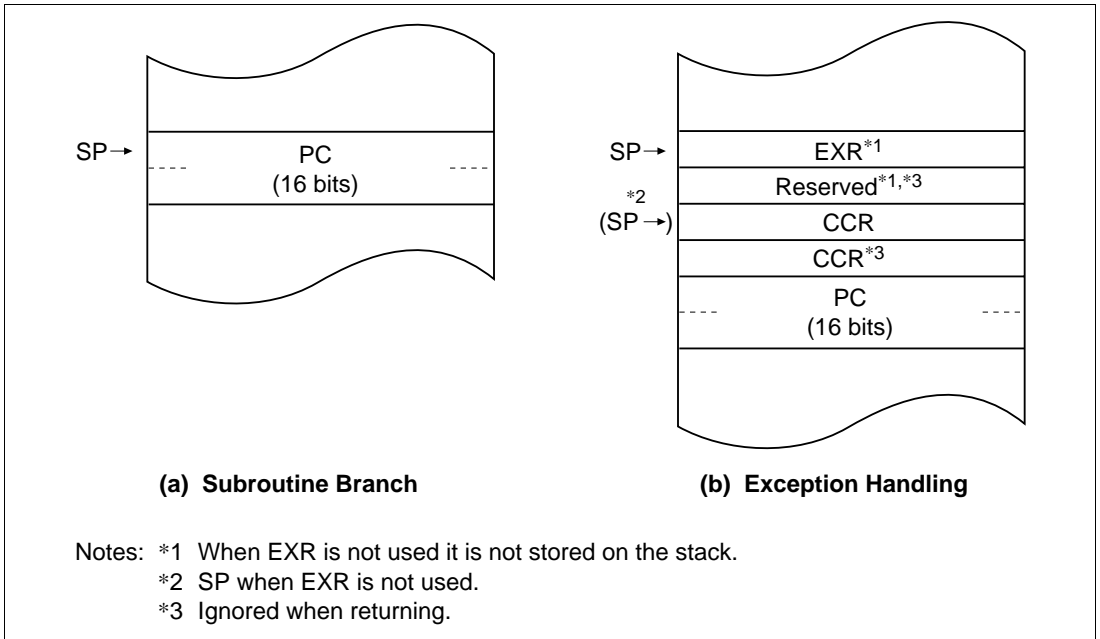
**Exception Vector Table and Memory Indirect Branch Addresses:** In normal mode the top area starting at H'0000 is allocated to the exception vector table. One branch address is stored per 16 bits. The configuration of the exception vector table in normal mode is shown in figure 2.2. For details of the exception vector table, see section 4, Exception Handling.



**Figure 2.2 Exception Vector Table (Normal Mode)**

The memory indirect addressing mode (@@aa:8) employed in the JMP and JSR instructions uses an 8-bit absolute address included in the instruction code to specify a memory operand that contains a branch address. In normal mode the operand is a 16-bit word operand, providing a 16-bit branch address. Branch addresses can be stored in the top area from H'0000 to H'00FF. Note that this area is also used for the exception vector table.

**Stack Structure:** When the program counter (PC) is pushed onto the stack in a subroutine call, and the PC, condition-code register (CCR), and extended control register (EXR) are pushed onto the stack in exception handling, they are stored as shown in figure 2.3. When EXR is invalid, it is not pushed onto the stack. For details, see section 4, Exception Handling.



**Figure 2.3 Stack Structure in Normal Mode**

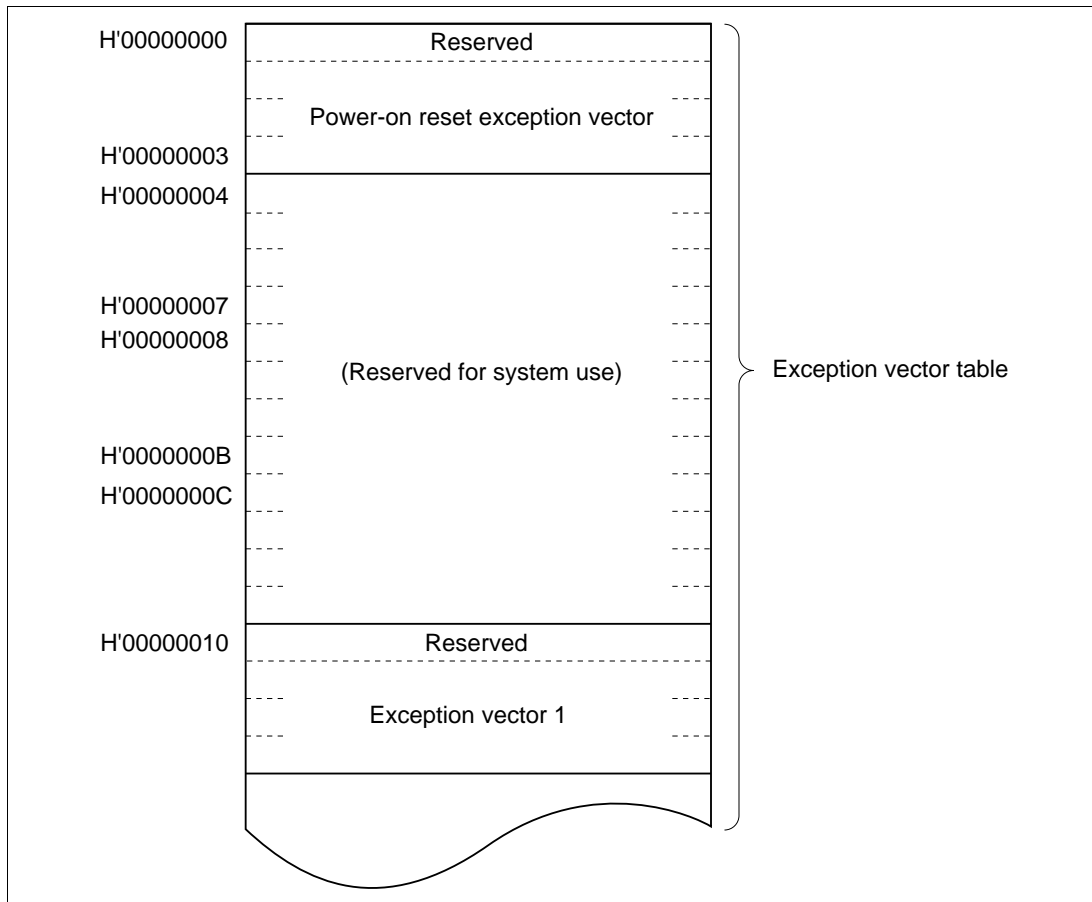
## (2) Advanced Mode

**Address Space:** Linear access is provided to a 16-Mbyte maximum address space (architecturally a maximum 16-Mbyte program area and a maximum 4-Gbyte data area, with a maximum of 4 Gbytes for program and data areas combined).

**Extended Registers (En):** The extended registers (E0 to E7) can be used as 16-bit registers, or as the upper 16-bit segments of 32-bit registers or address registers.

**Instruction Set:** All instructions and addressing modes can be used.

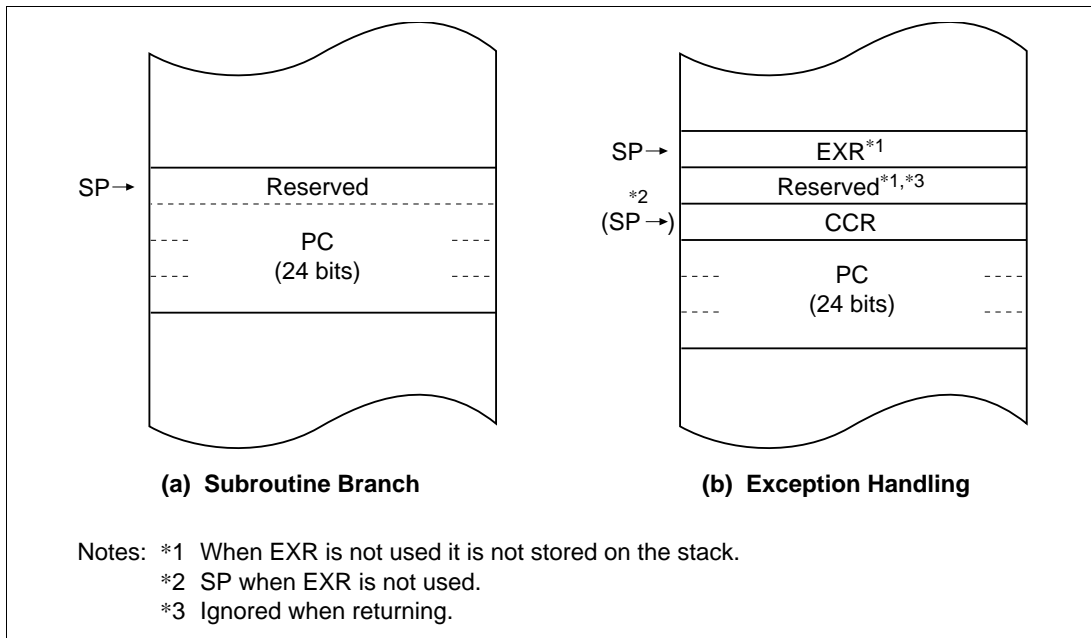
**Exception Vector Table and Memory Indirect Branch Addresses:** In advanced mode the top area starting at H'00000000 is allocated to the exception vector table in units of 32 bits. In each 32 bits, the upper 8 bits are ignored and a branch address is stored in the lower 24 bits (figure 2.4). For details of the exception vector table, see section 4, Exception Handling.



**Figure 2.4 Exception Vector Table (Advanced Mode)**

The memory indirect addressing mode (@@aa:8) employed in the JMP and JSR instructions uses an 8-bit absolute address included in the instruction code to specify a memory operand that contains a branch address. In advanced mode the operand is a 32-bit longword operand, providing a 32-bit branch address. The upper 8 bits of these 32 bits are a reserved area that is regarded as H'00. Branch addresses can be stored in the area from H'00000000 to H'000000FF. Note that the first part of this range is also the exception vector table.

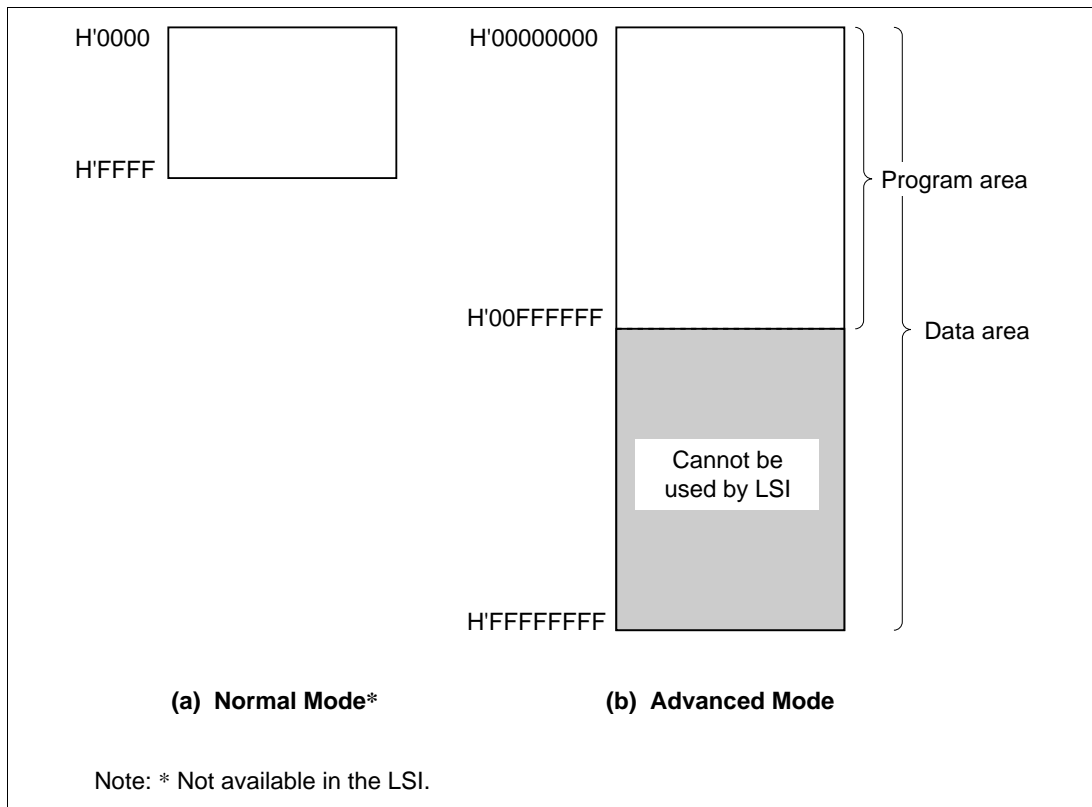
**Stack Structure:** In advanced mode, when the program counter (PC) is pushed onto the stack in a subroutine call, and the PC, condition-code register (CCR), and extended control register (EXR) are pushed onto the stack in exception handling, they are stored as shown in figure 2.5. When EXR is invalid, it is not pushed onto the stack. For details, see section 4, Exception Handling.



**Figure 2.5 Stack Structure in Advanced Mode**

## 2.3 Address Space

Figure 2.6 shows a memory map of the H8S/2000 CPU. The H8S/2000 CPU provides linear access to a maximum 64-kbyte address space in normal mode, and a maximum 16-Mbyte (architecturally 4-Gbyte) address space in advanced mode.



**Figure 2.6 Memory Map**

## 2.4 Register Configuration

### 2.4.1 Overview

The CPU has the internal registers shown in figure 2.7. There are two types of registers: general registers and control registers.

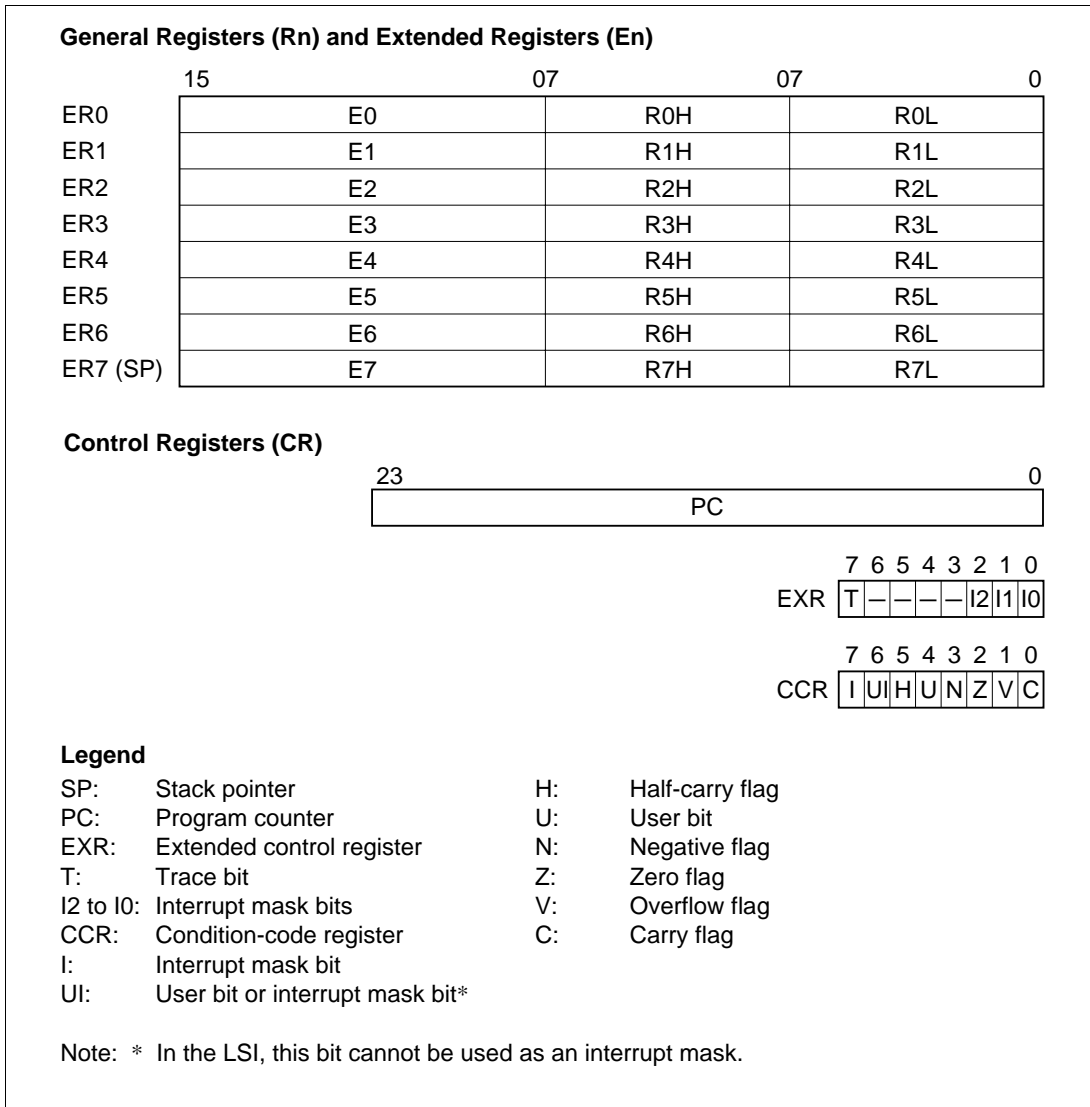


Figure 2.7 CPU Registers



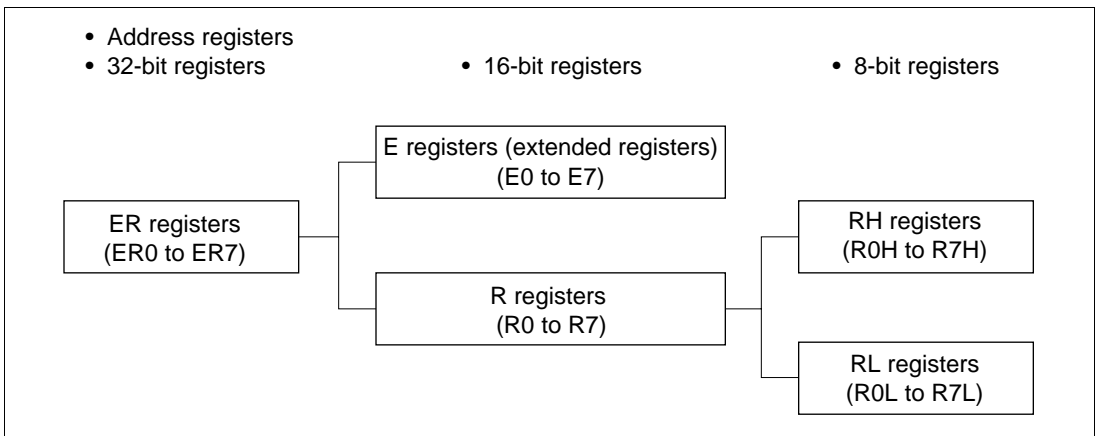
## 2.4.2 General Registers

The CPU has eight 32-bit general registers. These general registers are all functionally alike and can be used as both address registers and data registers. When a general register is used as a data register, it can be accessed as a 32-bit, 16-bit, or 8-bit register. When the general registers are used as 32-bit registers or address registers, they are designated by the letters ER (ER0 to ER7).

The ER registers divide into 16-bit general registers designated by the letters E (E0 to E7) and R (R0 to R7). These registers are functionally equivalent, providing a maximum sixteen 16-bit registers. The E registers (E0 to E7) are also referred to as extended registers.

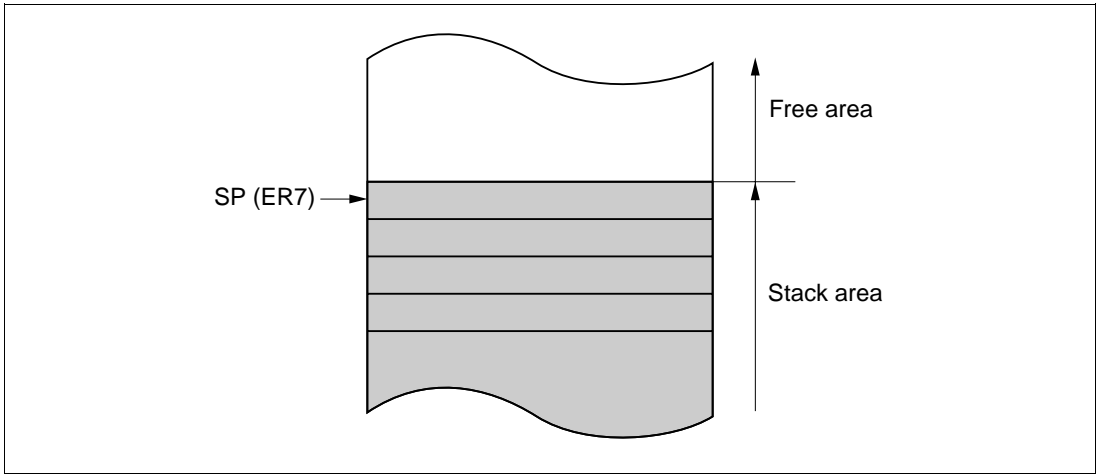
The R registers divide into 8-bit general registers designated by the letters RH (R0H to R7H) and RL (R0L to R7L). These registers are functionally equivalent, providing a maximum sixteen 8-bit registers.

Figure 2.8 illustrates the usage of the general registers. The usage of each register can be selected independently.



**Figure 2.8 Usage of General Registers**

General register ER7 has the function of stack pointer (SP) in addition to its general-register function, and is used implicitly in exception handling and subroutine calls. Figure 2.9 shows the stack.



**Figure 2.9 Stack**

### 2.4.3 Control Registers

The control registers are the 24-bit program counter (PC), 8-bit extended control register (EXR), and 8-bit condition-code register (CCR).

**(1) Program Counter (PC):** This 24-bit counter indicates the address of the next instruction the CPU will execute. The length of all CPU instructions is 2 bytes (one word), so the least significant PC bit is ignored. (When an instruction is fetched, the least significant PC bit is regarded as 0.)

**(2) Extended Control Register (EXR):** This 8-bit register contains the trace bit (T) and interrupt mask bit.

**Bit 7—Trace Bit (T):** Selects trace mode. When this bit is cleared to 0, instructions are executed in sequence. When this bit is set to 1, a trace exception is generated each time an instruction is executed.

**Bits 6 to 3—Reserved:** They are always read as 1.

**Bits 2 to 0—Interrupt Mask Bits (I2 to I0):** These bits designate the interrupt mask level (0 to 7). For details, refer to section 5, Interrupt Controller.

Operations can be performed on the EXR bits by the LDC, STC, ANDC, ORC, and XORC instructions. All interrupts, including NMI, are disabled for three states after one of these instructions is executed, except for STC.

**(3) Condition-Code Register (CCR):** This 8-bit register contains internal CPU status information, including an interrupt mask bit (I) and half-carry (H), negative (N), zero (Z), overflow (V), and carry (C) flags.

**Bit 7—Interrupt Mask Bit (I):** Masks interrupts other than NMI when set to 1. (NMI is accepted regardless of the I bit setting.) The I bit is set to 1 by hardware at the start of an exception-handling sequence. For details, refer to section 5, Interrupt Controller.

**Bit 6—User Bit or Interrupt Mask Bit (UI):** Can be written and read by software using the LDC, STC, ANDC, ORC, and XORC instructions. With the LSI, this bit cannot be used as an interrupt mask bit.

**Bit 5—Half-Carry Flag (H):** When the ADD.B, ADDX.B, SUB.B, SUBX.B, CMP.B, or NEG.B instruction is executed, this flag is set to 1 if there is a carry or borrow at bit 3, and cleared to 0 otherwise. When the ADD.W, SUB.W, CMP.W, or NEG.W instruction is executed, the H flag is set to 1 if there is a carry or borrow at bit 11, and cleared to 0 otherwise. When the ADD.L, SUB.L, CMP.L, or NEG.L instruction is executed, the H flag is set to 1 if there is a carry or borrow at bit 27, and cleared to 0 otherwise.

**Bit 4—User Bit (U):** Can be written and read by software using the LDC, STC, ANDC, ORC, and XORC instructions.

**Bit 3—Negative Flag (N):** Stores the value of the most significant bit (sign bit) of data.

**Bit 2—Zero Flag (Z):** Set to 1 to indicate zero data, and cleared to 0 to indicate non-zero data.

**Bit 1—Overflow Flag (V):** Set to 1 when an arithmetic overflow occurs, and cleared to 0 at other times.

**Bit 0—Carry Flag (C):** Set to 1 when a carry occurs, and cleared to 0 otherwise. Used by:

- Add instructions, to indicate a carry
- Subtract instructions, to indicate a borrow
- Shift and rotate instructions, to indicate a carry.

The carry flag is also used as a bit accumulator by bit manipulation instructions.

Some instructions leave some or all of the flag bits unchanged. For the action of each instruction on the flag bits, refer to Appendix A.1, List of Instructions.

Operations can be performed on the CCR bits by the LDC, STC, ANDC, ORC, and XORC instructions. The N, Z, V, and C flags are used as branching conditions for conditional branch (Bcc) instructions.

#### **2.4.4 Initial Register Values**

Reset exception handling loads the CPU's program counter (PC) from the vector table, clears the trace bit in EXR to 0, and sets the interrupt mask bits in CCR and EXR to 1. The other CCR bits and the general registers are not initialized. In particular, the stack pointer (ER7) is not initialized. The stack pointer should therefore be initialized by an MOV.L instruction executed immediately after a reset.

## 2.5 Data Formats

The CPU can process 1-bit, 4-bit (BCD), 8-bit (byte), 16-bit (word), and 32-bit (longword) data. Bit-manipulation instructions operate on 1-bit data by accessing bit  $n$  ( $n = 0, 1, 2, \dots, 7$ ) of byte operand data. The DAA and DAS decimal-adjust instructions treat byte data as two digits of 4-bit BCD data.

### 2.5.1 General Register Data Formats

Figure 2.10 shows the data formats in general registers.

Data Type	Register Number	Data Format
1-bit data	RnH	<p>7 0 7 6 5 4 3 2 1 0 Don't care</p>
1-bit data	RnL	<p>7 0 Don't care 7 6 5 4 3 2 1 0</p>
4-bit BCD data	RnH	<p>7 4 3 0 Upper Lower Don't care</p>
4-bit BCD data	RnL	<p>7 4 3 0 Don't care Upper Lower</p>
Byte data	RnH	<p>7 0 MSB LSB Don't care</p>
Byte data	RnL	<p>7 0 Don't care MSB LSB</p>

Figure 2.10 General Register Data Formats

Data Type	Register Number	Data Format
Word data	Rn	
Word data	En	
Longword data	ERn	

### Legend

ERn: General register ER

En: General register E

Rn: General register R

RnH: General register RH

RnL: General register RL

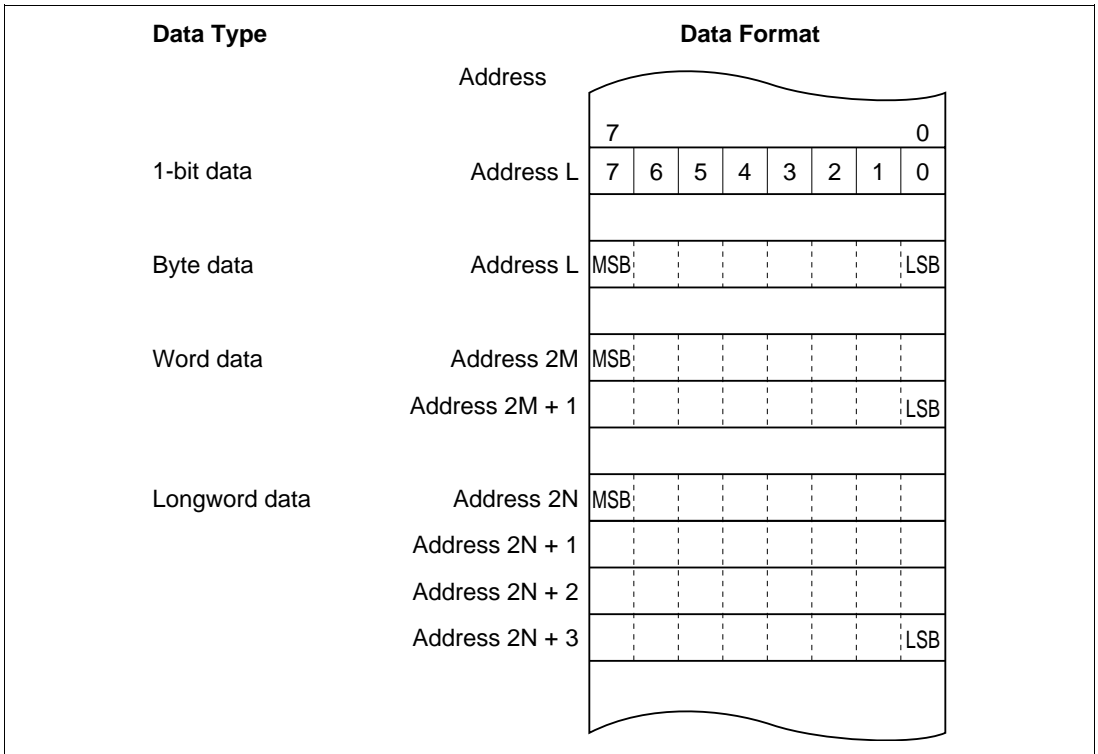
MSB: Most significant bit

LSB: Least significant bit

**Figure 2.10 General Register Data Formats (cont)**

## 2.5.2 Memory Data Formats

Figure 2.11 shows the data formats in memory. The CPU can access word data and longword data in memory, but word or longword data must begin at an even address. If an attempt is made to access word or longword data at an odd address, no address error occurs but the least significant bit of the address is regarded as 0, so the access starts at the preceding address. This also applies to instruction fetches.



**Figure 2.11 Memory Data Formats**

When SP (ER7) is used as an address register to access the stack, the operand size should be word size or longword size.

## 2.6 Instruction Set

### 2.6.1 Overview

The H8S/2000 CPU has 65 types of instructions. The instructions are classified by function in table 2.1.

**Table 2.1 Instruction Classification**

Function	Instructions	Size	Types
Data transfer	MOV	BWL	5
	POP* <sup>1</sup> , PUSH* <sup>1</sup>	WL	
	LDM, STM	L	
	MOVFP* <sup>3</sup> , MOVTP* <sup>3</sup>	B	
Arithmetic operations	ADD, SUB, CMP, NEG	BWL	19
	ADDX, SUBX, DAA, DAS	B	
	INC, DEC	BWL	
	ADDS, SUBS	L	
	MULXU, DIVXU, MULXS, DIVXS	BW	
	EXTU, EXTS	WL	
	TAS* <sup>4</sup>	B	
Logic operations	AND, OR, XOR, NOT	BWL	4
Shift	SHAL, SHAR, SHLL, SHLR, ROTL, ROTR, ROTXL, ROTXR	BWL	8
Bit manipulation	BSET, BCLR, BNOT, BTST, BLD, BILD, BST, BIST, BAND, BIAND, BOR, BIOR, BXOR, BIXOR	B	14
Branch	Bcc* <sup>2</sup> , JMP, BSR, JSR, RTS	—	5
System control	TRAPA, RTE, SLEEP, LDC, STC, ANDC, ORC, XORC, NOP	—	9
Block data transfer	EEPMOV	—	1

Total: 65

Notes: B-byte size; W-word size; L-longword size.

\*1 POP.W Rn and PUSH.W Rn are identical to MOV.W @SP+, Rn and MOV.W Rn, @-SP. POP.L ERn and PUSH.L ERn are identical to MOV.L @SP+, ERn and MOV.L ERn, @-SP.

\*2 Bcc is the general name for conditional branch instructions.

\*3 Cannot be used in the LSI.

\*4 Only register ER0, ER1, ER4, or ER5 should be used when using the TAS instruction.



## 2.6.2 Instructions and Addressing Modes

Table 2.2 indicates the combinations of instructions and addressing modes that the H8S/2000 CPU can use.

**Table 2.2 Combinations of Instructions and Addressing Modes**

Function	Instruction	Addressing Modes													
		#xx	Rn	@Rn	@(d:16,ERn)	@(d:32,ERn)	@-ERn/@ERn+	@aa:8	@aa:16	@aa:24	@aa:32	@(d:8,PC)	@(d:16,PC)	@aa:8	—
Data transfer	MOV	BWL	BWL	BWL	BWL	BWL	BWL	B	BWL	—	BWL	—	—	—	—
	POP, PUSH	—	—	—	—	—	—	—	—	—	—	—	—	—	WL
	LDM, STM	—	—	—	—	—	—	—	—	—	—	—	—	—	L
Arithmetic operations	MOVFP <sup>*1</sup> , MOVTP <sup>*1</sup>	—	—	—	—	—	—	—	—	—	B	—	—	—	—
	ADD, CMP	BWL	BWL	—	—	—	—	—	—	—	—	—	—	—	—
	SUB	WL	BWL	—	—	—	—	—	—	—	—	—	—	—	—
	ADDX, SUBX	B	B	—	—	—	—	—	—	—	—	—	—	—	—
	ADDS, SUBS	—	L	—	—	—	—	—	—	—	—	—	—	—	—
	INC, DEC	—	BWL	—	—	—	—	—	—	—	—	—	—	—	—
	DAA, DAS	—	B	—	—	—	—	—	—	—	—	—	—	—	—
	MULXU, DIVXU	—	BW	—	—	—	—	—	—	—	—	—	—	—	—
	MULXS, DIVXS	—	BW	—	—	—	—	—	—	—	—	—	—	—	—
	NEG	—	BWL	—	—	—	—	—	—	—	—	—	—	—	—
EXTU, EXTS	—	WL	—	—	—	—	—	—	—	—	—	—	—	—	
TAS <sup>*2</sup>	—	—	—	B	—	—	—	—	—	—	—	—	—	—	



## 2.6.3 Table of Instructions Classified by Function

Table 2.3 summarizes the instructions in each functional category. The notation used in table 2.3 is defined below.

### Operation Notation

Rd	General register (destination)*
Rs	General register (source)*
Rn	General register*
ERn	General register (32-bit register)
(EAd)	Destination operand
(EAs)	Source operand
EXR	Extended control register
CCR	Condition-code register
N	N (negative) flag in CCR
Z	Z (zero) flag in CCR
V	V (overflow) flag in CCR
C	C (carry) flag in CCR
PC	Program counter
SP	Stack pointer
#IMM	Immediate data
disp	Displacement
+	Addition
−	Subtraction
×	Multiplication
÷	Division
∧	Logical AND
∨	Logical OR
⊕	Logical exclusive OR
→	Move
¬	NOT (logical complement)
:8/:16/:24/:32	8-, 16-, 24-, or 32-bit length

Note: \* General registers include 8-bit registers (R0H to R7H, R0L to R7L), 16-bit registers (R0 to R7, E0 to E7), and 32-bit registers (ER0 to ER7).

**Table 2.3 Instructions Classified by Function**

Type	Instruction	Size* <sup>1</sup>	Function
Data transfer	MOV	B/W/L	(EAs) → Rd, Rs → (EAd) Moves data between two general registers or between a general register and memory, or moves immediate data to a general register.
	MOVFPPE	B	Cannot be used in the LSI.
	MOVTPPE	B	Cannot be used in the LSI.
	POP	W/L	@SP+ → Rn Pops a register from the stack. POP.W Rn is identical to MOV.W @SP+, Rn. POP.L ERn is identical to MOV.L @SP+, ERn.
	PUSH	W/L	Rn → @-SP Pushes a register onto the stack. PUSH.W Rn is identical to MOV.W Rn, @-SP. PUSH.L ERn is identical to MOV.L ERn, @-SP.
	LDM	L	@SP+ → Rn (register list) Pops two or more general registers from the stack.
	STM	L	Rn (register list) → @-SP Pushes two or more general registers onto the stack.
Arithmetic operations	ADD SUB	B/W/L	$Rd \pm Rs \rightarrow Rd$ , $Rd \pm \#IMM \rightarrow Rd$ Performs addition or subtraction on data in two general registers, or on immediate data and data in a general register. (Immediate byte data cannot be subtracted from byte data in a general register. Use the SUBX or ADD instruction.)
	ADDX SUBX	B	$Rd \pm Rs \pm C \rightarrow Rd$ , $Rd \pm \#IMM \pm C \rightarrow Rd$ Performs addition or subtraction with carry or borrow on byte data in two general registers, or on immediate data and data in a general register.
	INC DEC	B/W/L	$Rd \pm 1 \rightarrow Rd$ , $Rd \pm 2 \rightarrow Rd$ Increments or decrements a general register by 1 or 2. (Byte operands can be incremented or decremented by 1 only.)
	ADDS SUBS	L	$Rd \pm 1 \rightarrow Rd$ , $Rd \pm 2 \rightarrow Rd$ , $Rd \pm 4 \rightarrow Rd$ Adds or subtracts the value 1, 2, or 4 to or from data in a 32-bit register.
	DAA DAS	B	$Rd \text{ decimal adjust} \rightarrow Rd$ Decimal-adjusts an addition or subtraction result in a general register by referring to the CCR to produce 4-bit BCD data.

Type	Instruction	Size* <sup>1</sup>	Function
Arithmetic operations	MULXU	B/W	$Rd \times Rs \rightarrow Rd$ Performs unsigned multiplication on data in two general registers: either 8 bits $\times$ 8 bits $\rightarrow$ 16 bits or 16 bits $\times$ 16 bits $\rightarrow$ 32 bits.
	MULXS	B/W	$Rd \times Rs \rightarrow Rd$ Performs signed multiplication on data in two general registers: either 8 bits $\times$ 8 bits $\rightarrow$ 16 bits or 16 bits $\times$ 16 bits $\rightarrow$ 32 bits.
	DIVXU	B/W	$Rd \div Rs \rightarrow Rd$ Performs unsigned division on data in two general registers: either 16 bits $\div$ 8 bits $\rightarrow$ 8-bit quotient and 8-bit remainder or 32 bits $\div$ 16 bits $\rightarrow$ 16-bit quotient and 16-bit remainder.
	DIVXS	B/W	$Rd \div Rs \rightarrow Rd$ Performs signed division on data in two general registers: either 16 bits $\div$ 8 bits $\rightarrow$ 8-bit quotient and 8-bit remainder or 32 bits $\div$ 16 bits $\rightarrow$ 16-bit quotient and 16-bit remainder.
	CMP	B/W/L	$Rd - Rs, Rd - \#IMM$ Compares data in a general register with data in another general register or with immediate data, and sets CCR bits according to the result.
	NEG	B/W/L	$0 - Rd \rightarrow Rd$ Takes the two's complement (arithmetic complement) of data in a general register.
	EXTU	W/L	$Rd$ (zero extension) $\rightarrow Rd$ Extends the lower 8 bits of a 16-bit register to word size, or the lower 16 bits of a 32-bit register to longword size, by padding with zeros on the left.
	EXTS	W/L	$Rd$ (sign extension) $\rightarrow Rd$ Extends the lower 8 bits of a 16-bit register to word size, or the lower 16 bits of a 32-bit register to longword size, by extending the sign bit.
	TAS	B	$@ERd - 0, 1 \rightarrow (<bit 7> \text{ of } @ERd)^{*2}$ Tests memory contents, and sets the most significant bit (bit 7) to 1.

Type	Instruction	Size*1	Function
Logic operations	AND	B/W/L	$Rd \wedge Rs \rightarrow Rd$ , $Rd \wedge \#IMM \rightarrow Rd$ Performs a logical AND operation on a general register and another general register or immediate data.
	OR	B/W/L	$Rd \vee Rs \rightarrow Rd$ , $Rd \vee \#IMM \rightarrow Rd$ Performs a logical OR operation on a general register and another general register or immediate data.
	XOR	B/W/L	$Rd \oplus Rs \rightarrow Rd$ , $Rd \oplus \#IMM \rightarrow Rd$ Performs a logical exclusive OR operation on a general register and another general register or immediate data.
	NOT	B/W/L	$\neg (Rd) \rightarrow (Rd)$ Takes the one's complement of general register contents.
Shift operations	SHAL SHAR	B/W/L	$Rd \text{ (shift)} \rightarrow Rd$ Performs an arithmetic shift on general register contents. 1-bit or 2-bit shift is possible.
	SHLL SHLR	B/W/L	$Rd \text{ (shift)} \rightarrow Rd$ Performs a logical shift on general register contents. 1-bit or 2-bit shift is possible.
	ROTL ROTR	B/W/L	$Rd \text{ (rotate)} \rightarrow Rd$ Rotates general register contents. 1-bit or 2-bit rotation is possible.
	ROTXL ROTXR	B/W/L	$Rd \text{ (rotate)} \rightarrow Rd$ Rotates general register contents through the carry flag. 1-bit or 2-bit rotation is possible.
Bit-manipulation instructions	BSET	B	$1 \rightarrow \langle \text{bit-No.} \rangle \text{ of } \langle \text{EAd} \rangle$ Sets a specified bit in a general register or memory operand to 1. The bit number is specified by 3-bit immediate data or the lower three bits of a general register.
	BCLR	B	$0 \rightarrow \langle \text{bit-No.} \rangle \text{ of } \langle \text{EAd} \rangle$ Clears a specified bit in a general register or memory operand to 0. The bit number is specified by 3-bit immediate data or the lower three bits of a general register.
	BNOT	B	$\neg \langle \text{bit-No.} \rangle \text{ of } \langle \text{EAd} \rangle \rightarrow \langle \text{bit-No.} \rangle \text{ of } \langle \text{EAd} \rangle$ Inverts a specified bit in a general register or memory operand. The bit number is specified by 3-bit immediate data or the lower three bits of a general register.

Type	Instruction	Size*1	Function
Bit-manipulation instructions	BTST	B	$\neg$ (<bit-No.> of <EAd>) $\rightarrow$ Z Tests a specified bit in a general register or memory operand and sets or clears the Z flag accordingly. The bit number is specified by 3-bit immediate data or the lower three bits of a general register.
	BAND	B	$C \wedge$ (<bit-No.> of <EAd>) $\rightarrow$ C ANDs the carry flag with a specified bit in a general register or memory operand and stores the result in the carry flag.
	BIAND	B	$C \wedge [\neg$ (<bit-No.> of <EAd>)] $\rightarrow$ C ANDs the carry flag with the inverse of a specified bit in a general register or memory operand and stores the result in the carry flag. The bit number is specified by 3-bit immediate data.
	BOR	B	$C \vee$ (<bit-No.> of <EAd>) $\rightarrow$ C ORs the carry flag with a specified bit in a general register or memory operand and stores the result in the carry flag.
	BIOR	B	$C \vee [\neg$ (<bit-No.> of <EAd>)] $\rightarrow$ C ORs the carry flag with the inverse of a specified bit in a general register or memory operand and stores the result in the carry flag. The bit number is specified by 3-bit immediate data.
	BXOR	B	$C \oplus$ (<bit-No.> of <EAd>) $\rightarrow$ C Exclusive-ORs the carry flag with a specified bit in a general register or memory operand and stores the result in the carry flag.
	BIXOR	B	$C \oplus [\neg$ (<bit-No.> of <EAd>)] $\rightarrow$ C Exclusive-ORs the carry flag with the inverse of a specified bit in a general register or memory operand and stores the result in the carry flag. The bit number is specified by 3-bit immediate data.
	BLD	B	(<bit-No.> of <EAd>) $\rightarrow$ C Transfers a specified bit in a general register or memory operand to the carry flag.
	BILD	B	$\neg$ (<bit-No.> of <EAd>) $\rightarrow$ C Transfers the inverse of a specified bit in a general register or memory operand to the carry flag. The bit number is specified by 3-bit immediate data.

Type	Instruction	Size*1	Function		
Bit-manipulation instructions	BST	B	$C \rightarrow$ (<bit-No.> of <EAd>) Transfers the carry flag value to a specified bit in a general register or memory operand.		
	BIST	B	$\neg C \rightarrow$ (<bit-No.> of <EAd>) Transfers the inverse of the carry flag value to a specified bit in a general register or memory operand. The bit number is specified by 3-bit immediate data.		
Branch instructions	Bcc	—	Branches to a specified address if a specified condition is true. The branching conditions are listed below.		
			<b>Mnemonic</b>	<b>Description</b>	<b>Condition</b>
			BRA(BT)	Always (true)	Always
			BRN(BF)	Never (false)	Never
			BHI	High	$C \vee Z = 0$
			BLS	Low or same	$C \vee Z = 1$
			BCC(BHS)	Carry clear (high or same)	$C = 0$
			BCS(BLO)	Carry set (low)	$C = 1$
			BNE	Not equal	$Z = 0$
			BEQ	Equal	$Z = 1$
			BVC	Overflow clear	$V = 0$
			BVS	Overflow set	$V = 1$
			BPL	Plus	$N = 0$
			BMI	Minus	$N = 1$
			BGE	Greater or equal	$N \oplus V = 0$
			BLT	Less than	$N \oplus V = 1$
			BGT	Greater than	$Z \vee (N \oplus V) = 0$
BLE	Less or equal	$Z \vee (N \oplus V) = 1$			
System control instructions	JMP	—	Branches unconditionally to a specified address.		
	BSR	—	Branches to a subroutine at a specified address.		
	JSR	—	Branches to a subroutine at a specified address.		
	RTS	—	Returns from a subroutine		
	TRAPA	—	Starts trap-instruction exception handling.		
	RTE	—	Returns from an exception-handling routine.		
	SLEEP	—	Causes a transition to a power-down state.		



Type	Instruction	Size* <sup>1</sup>	Function
System control instructions	LDC	B/W	(EAs) → CCR, (EAs) → EXR Moves the source operand contents or immediate data to CCR or EXR. Although CCR and EXR are 8-bit registers, word-size transfers are performed between them and memory. The upper 8 bits are valid.
	STC	B/W	CCR → (EAd), EXR → (EAd) Transfers CCR or EXR contents to a general register or memory. Although CCR and EXR are 8-bit registers, word-size transfers are performed between them and memory. The upper 8 bits are valid.
	ANDC	B	CCR ∧ #IMM → CCR, EXR ∧ #IMM → EXR Logically ANDs the CCR or EXR contents with immediate data.
	ORC	B	CCR ∨ #IMM → CCR, EXR ∨ #IMM → EXR Logically ORs the CCR or EXR contents with immediate data.
	XORC	B	CCR ⊕ #IMM → CCR, EXR ⊕ #IMM → EXR Logically exclusive-ORs the CCR or EXR contents with immediate data.
	NOP	—	PC + 2 → PC Only increments the program counter.
Block data transfer instruction	EPMOV.B	—	if R4L ≠ 0 then Repeat @ER5+ → @ER6+ R4L-1 → R4L Until R4L = 0 else next;
	EPMOV.W	—	if R4 ≠ 0 then Repeat @ER5+ → @ER6+ R4-1 → R4 Until R4 = 0 else next;  Transfers a data block according to parameters set in general registers R4L or R4, ER5, and ER6.  R4L or R4: size of block (bytes) ER5: starting source address ER6: starting destination address  Execution of the next instruction begins as soon as the transfer is completed.

Notes: \*1 Size refers to the operand size.

B: Byte

W: Word

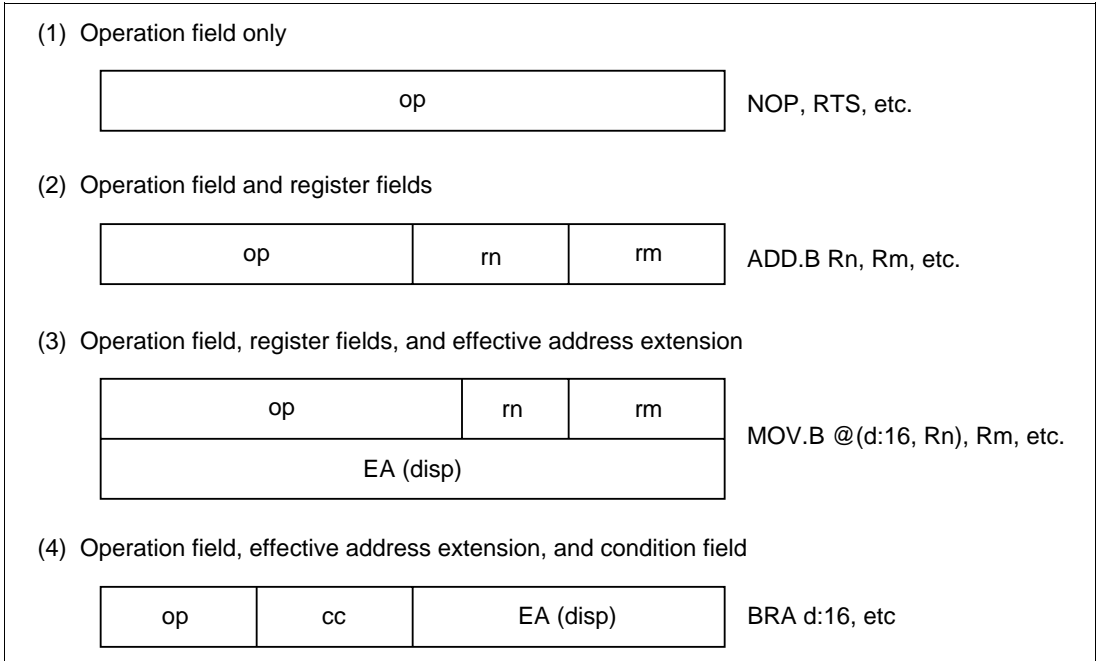
L: Longword

\*2 Only register ER0, ER1, ER4, or ER5 should be used when using the TAS instruction.

## 2.6.4 Basic Instruction Formats

The CPU instructions consist of 2-byte (1-word) units. An instruction consists of an operation field (op field), a register field (r field), an effective address extension (EA field), and a condition field (cc field).

Figure 2.12 shows examples of instruction formats.



**Figure 2.12 Instruction Formats (Examples)**

(1) **Operation Field:** Indicates the function of the instruction, the addressing mode, and the operation to be carried out on the operand. The operation field always includes the first four bits of the instruction. Some instructions have two operation fields.

(2) **Register Field:** Specifies a general register. Address registers are specified by 3 bits, data registers by 3 bits or 4 bits. Some instructions have two register fields. Some have no register field.

(3) **Effective Address Extension:** Eight, 16, or 32 bits specifying immediate data, an absolute address, or a displacement.

(4) **Condition Field:** Specifies the branching condition of Bcc instructions.

## 2.6.5 Notes on Use of Bit-Manipulation Instructions

The BSET, BCLR, BNOT, BST, and BIST instructions read a byte of data, carry out bit manipulation, then write back the byte of data. Caution is therefore required when using these instructions on a register containing write-only bits, or a port.

The BCLR instruction can be used to clear internal I/O register flags to 0. In this case, the relevant flag need not be read beforehand if it is clear that it has been set to 1 in an interrupt handling routine, etc.

## 2.7 Addressing Modes and Effective Address Calculation

### 2.7.1 Addressing Mode

The H8S/2000 CPU supports the eight addressing modes listed in table 2.4. Each instruction uses a subset of these addressing modes. Arithmetic and logic instructions can use the register direct and immediate modes. Data transfer instructions can use all addressing modes except program-counter relative and memory indirect. Bit manipulation instructions use register direct, register indirect, or absolute addressing mode to specify an operand, and register direct (BSET, BCLR, BNOT, and BTST instructions) or immediate (3-bit) addressing mode to specify a bit number in the operand.

**Table 2.4** Addressing Modes

No.	Addressing Mode	Symbol
1	Register direct	Rn
2	Register indirect	@ERn
3	Register indirect with displacement	@(d:16,ERn)/@(d:32,ERn)
4	Register indirect with post-increment Register indirect with pre-decrement	@ERn+ @-ERn
5	Absolute address	@aa:8/@aa:16/@aa:24/@aa:32
6	Immediate	#xx:8/#xx:16/#xx:32
7	Program-counter relative	@(d:8,PC)/@(d:16,PC)
8	Memory indirect	@ @aa:8

**(1) Register Direct—Rn:** The register field of the instruction specifies an 8-, 16-, or 32-bit general register containing the operand. R0H to R7H and R0L to R7L can be specified as 8-bit registers. R0 to R7 and E0 to E7 can be specified as 16-bit registers. ER0 to ER7 can be specified as 32-bit registers.

(2) **Register Indirect**—@ERn: The register field of the instruction code specifies an address register (ERn) which contains the address of the operand on memory. If the address is a program instruction address, the lower 24 bits are valid and the upper 8 bits are all assumed to be 0 (H'00).

(3) **Register Indirect with Displacement**—@(d:16, ERn) or @(d:32, ERn): A 16-bit or 32-bit displacement contained in the instruction is added to an address register (ERn) specified by the register field of the instruction, and the sum gives the address of a memory operand. A 16-bit displacement is sign-extended when added.

(4) **Register Indirect with Post-Increment or Pre-Decrement**—@ERn+ or @-ERn:

- Register indirect with post-increment—@ERn+

The register field of the instruction code specifies an address register (ERn) which contains the address of a memory operand. After the operand is accessed, 1, 2, or 4 is added to the address register contents and the sum is stored in the address register. The value added is 1 for byte access, 2 for word transfer instruction, or 4 for longword transfer instruction. For word or longword transfer instruction, the register value should be even.

- Register indirect with pre-decrement—@-ERn

The value 1, 2, or 4 is subtracted from an address register (ERn) specified by the register field in the instruction code, and the result becomes the address of a memory operand. The result is also stored in the address register. The value subtracted is 1 for byte access, 2 for word transfer instruction, or 4 for longword transfer instruction. For word or longword transfer instruction, the register value should be even.

(5) **Absolute Address**—@aa:8, @aa:16, @aa:24, or @aa:32: The instruction code contains the absolute address of a memory operand. The absolute address may be 8 bits long (@aa:8), 16 bits long (@aa:16), 24 bits long (@aa:24), or 32 bits long (@aa:32).

To access data, the absolute address should be 8 bits (@aa:8), 16 bits (@aa:16), or 32 bits (@aa:32) long. For an 8-bit absolute address, the upper 24 bits are all assumed to be 1 (H'FFFFFF). For a 16-bit absolute address the upper 16 bits are a sign extension. A 32-bit absolute address can access the entire address space.

A 24-bit absolute address (@aa:24) indicates the address of a program instruction. The upper 8 bits are all assumed to be 0 (H'00).

Table 2.5 indicates the accessible absolute address ranges.

**Table 2.5 Absolute Address Access Ranges**

<b>Absolute Address</b>		<b>Normal Mode*</b>	<b>Advanced Mode</b>
Data address	8 bits (@aa:8)	H'FF00 to H'FFFF	H'FFFF00 to H'FFFFFF
	16 bits (@aa:16)	H'0000 to H'FFFF	H'000000 to H'007FFF, H'FF8000 to H'FFFFFF
	32 bits (@aa:32)		H'000000 to H'FFFFFF
Program instruction address	24 bits (@aa:24)		

Note: \* Not available in the LSI.

**(6) Immediate—#xx:8, #xx:16, or #xx:32:** The instruction contains 8-bit (#xx:8), 16-bit (#xx:16), or 32-bit (#xx:32) immediate data as an operand.

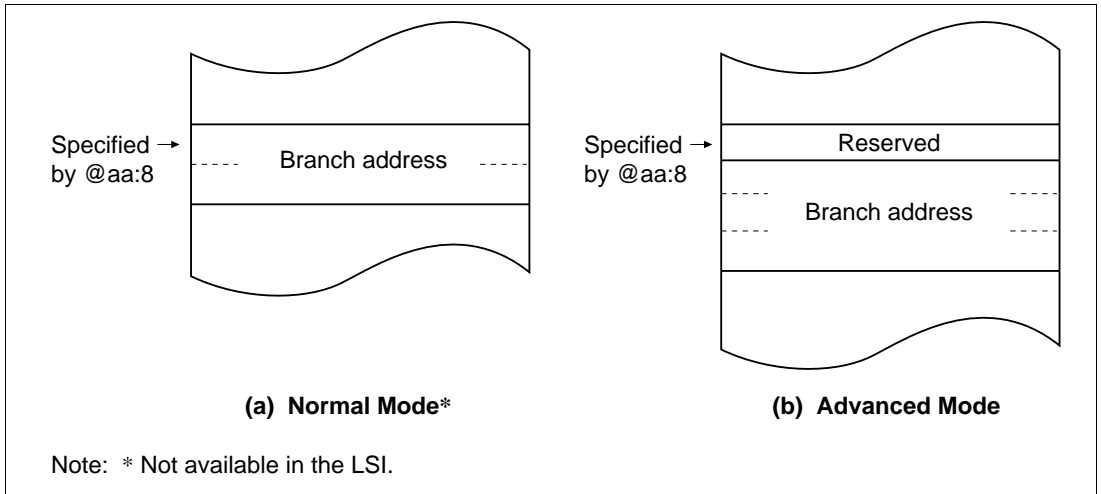
The ADDS, SUBS, INC, and DEC instructions contain immediate data implicitly. Some bit manipulation instructions contain 3-bit immediate data in the instruction code, specifying a bit number. The TRAPA instruction contains 2-bit immediate data in its instruction code, specifying a vector address.

**(7) Program-Counter Relative—@(d:8, PC) or @(d:16, PC):** This mode is used in the Bcc and BSR instructions. An 8-bit or 16-bit displacement contained in the instruction is sign-extended and added to the 24-bit PC contents to generate a branch address. Only the lower 24 bits of this branch address are valid; the upper 8 bits are all assumed to be 0 (H'00). The PC value to which the displacement is added is the address of the first byte of the next instruction, so the possible branching range is -126 to +128 bytes (-63 to +64 words) or -32766 to +32768 bytes (-16383 to +16384 words) from the branch instruction. The resulting value should be an even number.

**(8) Memory Indirect—@@aa:8:** This mode can be used by the JMP and JSR instructions. The instruction code contains an 8-bit absolute address specifying a memory operand. This memory operand contains a branch address. The upper bits of the absolute address are all assumed to be 0, so the address range is 0 to 255 (H'0000 to H'00FF\* in normal mode, H'000000 to H'0000FF in advanced mode). In normal mode the memory operand is a word operand and the branch address is 16 bits long. In advanced mode the memory operand is a longword operand, the first byte of which is assumed to be all 0 (H'00).

Note that the first part of the address range is also the exception vector area. For further details, refer to section 4, Exception Handling.

Note: \* Not available in the LSI.



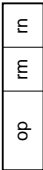




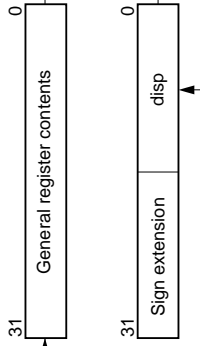
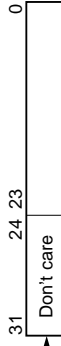
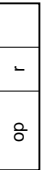
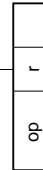
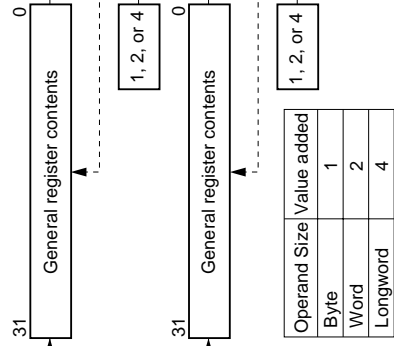

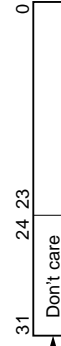
**Figure 2.13 Branch Address Specification in Memory Indirect Mode**






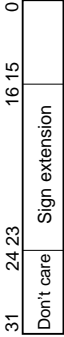
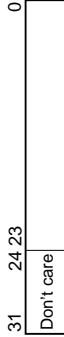
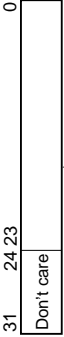

If an odd address is specified in word or longword memory access, or as a branch address, the least significant bit is regarded as 0, causing data to be accessed or instruction code to be fetched at the address preceding the specified address. (For further information, see section 2.5.2, Memory Data Formats.)

### 2.7.2 Effective Address Calculation

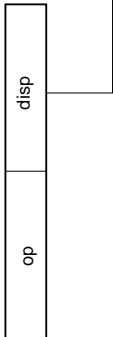
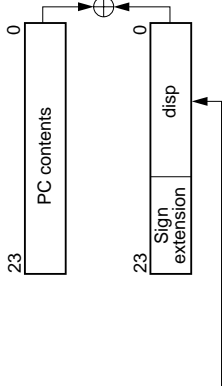
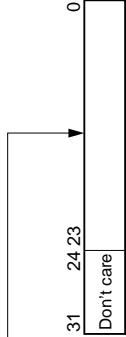
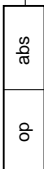
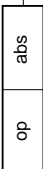
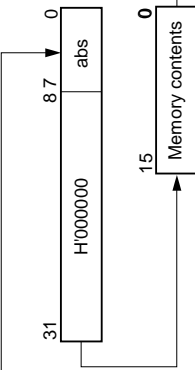
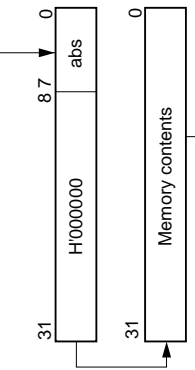


Table 2.6 indicates how effective addresses are calculated in each addressing mode. In normal mode the upper 8 bits of the effective address are ignored in order to generate a 16-bit address.

**Table 2.6 Effective Address Calculation**

No.	Addressing Mode and Instruction Format	Effective Address Calculation	Effective Address (EA)								
1	Register direct (Rn) 		Operand is general register contents.								
2	Register indirect (@ERn) 										
3	Register indirect with displacement @(d:16, ERn) or @(d:32, ERn) 										
4	Register indirect with post-increment or pre-decrement • Register indirect with post-increment @ERn+  • Register indirect with pre-decrement @-ERn 	 <table border="1" data-bbox="960 675 1069 898"> <thead> <tr> <th>Operand Size</th> <th>Value added</th> </tr> </thead> <tbody> <tr> <td>Byte</td> <td>1</td> </tr> <tr> <td>Word</td> <td>2</td> </tr> <tr> <td>Longword</td> <td>4</td> </tr> </tbody> </table>	Operand Size	Value added	Byte	1	Word	2	Longword	4	 
Operand Size	Value added										
Byte	1										
Word	2										
Longword	4										

No.	Addressing Mode and Instruction Format	Effective Address Calculation	Effective Address (EA)
5	<p>Absolute address</p> <p>@aa:8</p>  <p>@aa:16</p>  <p>@aa:24</p>  <p>@aa:32</p> 		   
6	<p>Immediate #xx:8/#xx:16/#xx:32</p> 		<p>Operand is immediate data.</p>



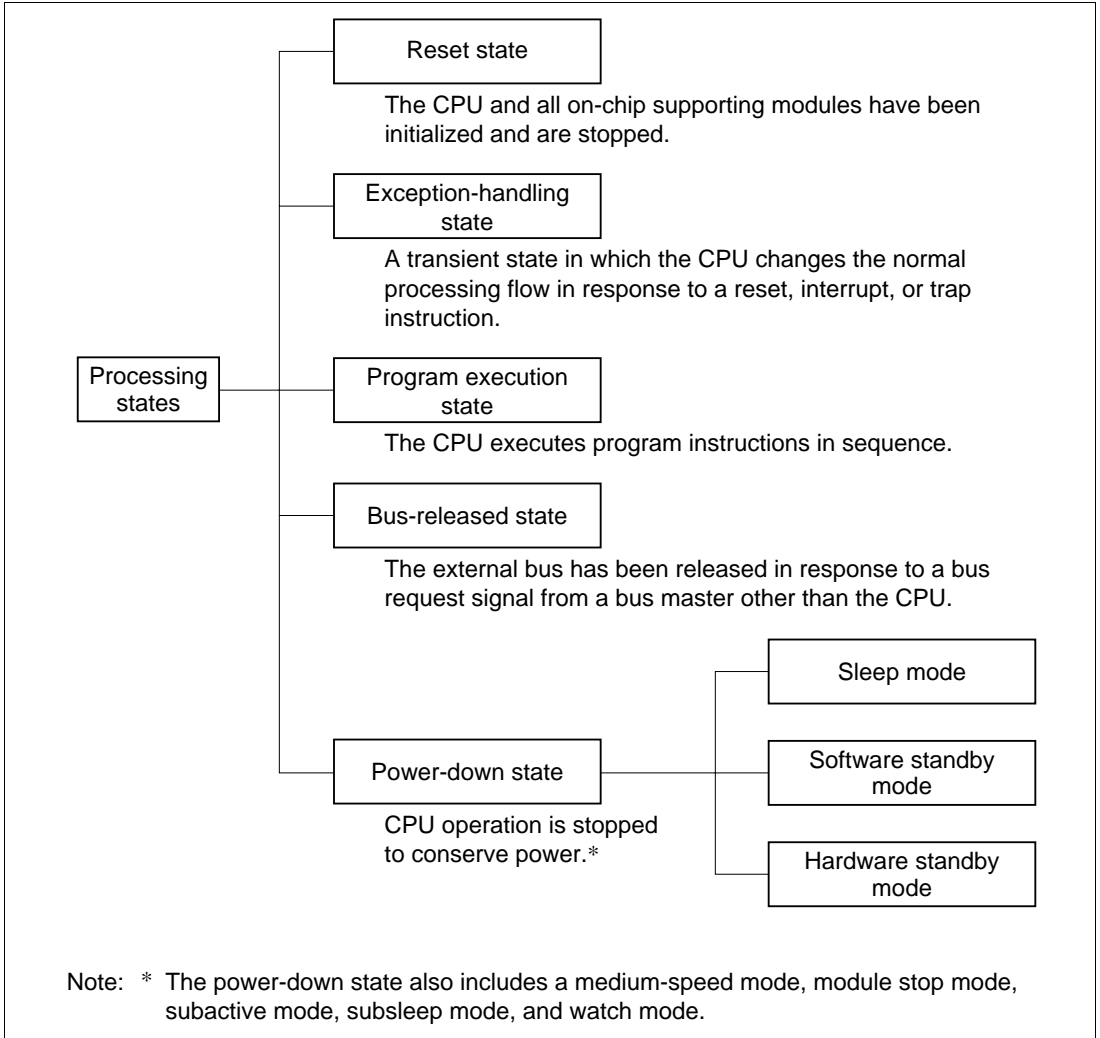
No.	Addressing Mode and Instruction Format	Effective Address Calculation	Effective Address (EA)
7	<p>Program-counter relative @(d:8, PC)/(d:16, PC)</p> 		
8	<p>Memory indirect @aa:8</p> <ul style="list-style-type: none"> <li>Normal mode*</li> </ul>  <ul style="list-style-type: none"> <li>Advanced mode</li> </ul> 	 	 

Note: \* Not available in the LSI.

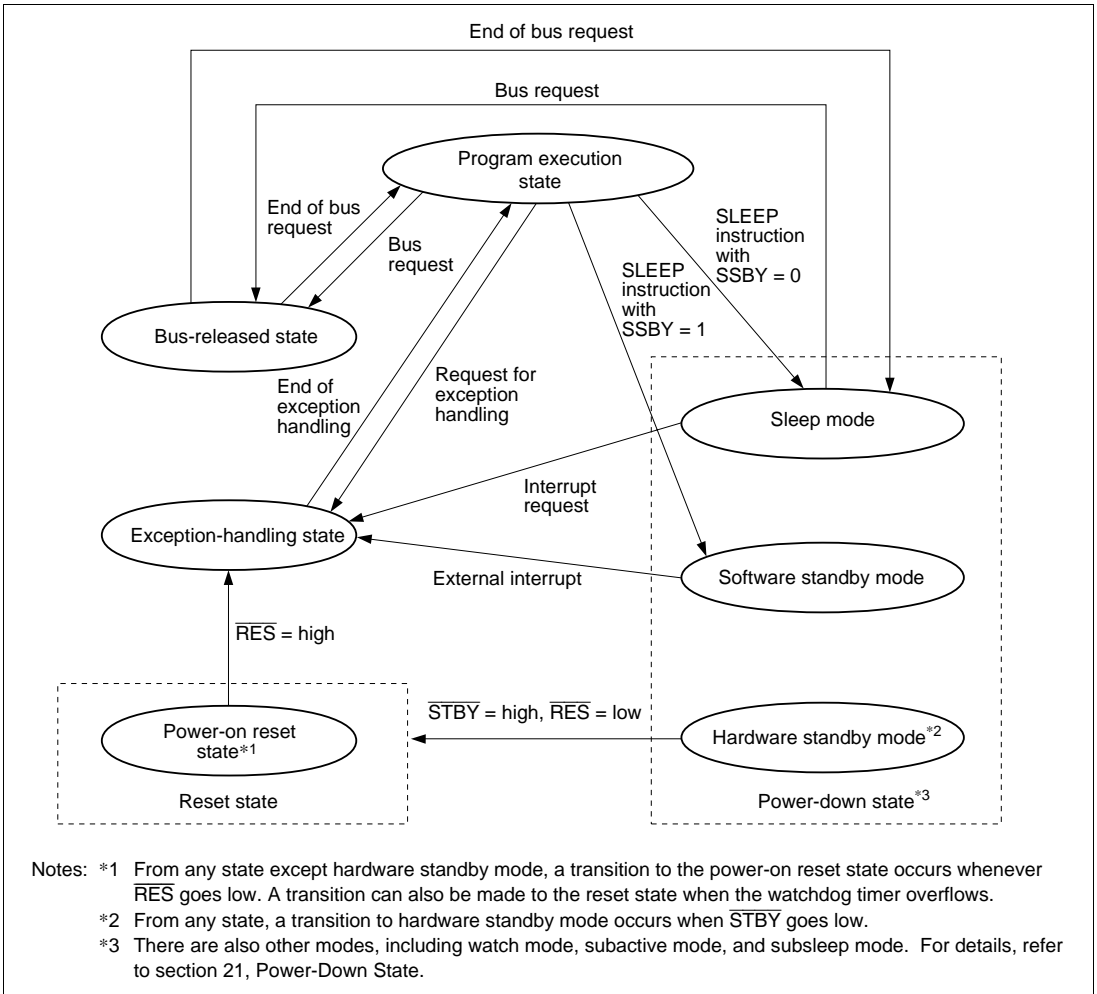
## 2.8 Processing States

### 2.8.1 Overview

The CPU has five main processing states: the reset state, exception handling state, program execution state, bus-released state, and power-down state. Figure 2.14 shows a diagram of the processing states. Figure 2.15 indicates the state transitions.



**Figure 2.14 Processing States**



**Figure 2.15 State Transitions**

## 2.8.2 Reset State

When the  $\overline{RES}$  input goes low all current processing stops and the CPU enters the power-on reset state. All interrupts are disabled in the reset state. Reset exception handling starts when the  $\overline{RES}$  signal changes from low to high.

The reset state can also be entered by a watchdog timer overflow. For details, refer to section 12, Watchdog Timer.

### 2.8.3 Exception-Handling State

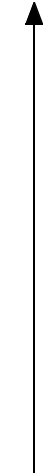
The exception-handling state is a transient state that occurs when the CPU alters the normal processing flow due to a reset, interrupt, or trap instruction. The CPU fetches a start address (vector) from the exception vector table and branches to that address.

#### (1) Types of Exception Handling and Their Priority

Exception handling is performed for resets, traces, interrupts, and trap instructions. Table 2.7 indicates the types of exception handling and their priority. Trap instruction exception handling is always accepted, in the program execution state.

Exception handling and the stack structure depend on the interrupt control mode set in SYSCR.

**Table 2.7 Exception Handling Types and Priority**

Priority	Type of Exception	Detection Timing	Start of Exception Handling
 High	Reset	Synchronized with clock	Exception handling starts immediately after a low-to-high transition at the $\overline{\text{RES}}$ pin, or when the watchdog timer overflows.
	Trace	End of instruction execution or end of exception-handling sequence* <sup>1</sup>	When the trace (T) bit is set to 1, the trace starts at the end of the current instruction or current exception-handling sequence
	Interrupt	End of instruction execution or end of exception-handling sequence* <sup>2</sup>	When an interrupt is requested, exception handling starts at the end of the current instruction or current exception-handling sequence
	Trap instruction	When TRAPA instruction is executed	Exception handling starts when a trap (TRAPA) instruction is executed* <sup>3</sup>
Low			

Notes: \*1 Traces are enabled only in interrupt control mode 2. Trace exception-handling is not executed at the end of the RTE instruction.

\*2 Interrupts are not detected at the end of the ANDC, ORC, XORC, and LDC instructions, or immediately after reset exception handling.

\*3 Trap instruction exception handling is always accepted, in the program execution state.

## (2) Reset Exception Handling

After the  $\overline{\text{RES}}$  pin has gone low and the reset state has been entered, reset exception handling starts when  $\overline{\text{RES}}$  goes high again. When reset exception handling starts the CPU fetches a start address (vector) from the exception vector table and starts program execution from that address. All interrupts, including NMI, are disabled during reset exception handling and after it ends.

## (3) Traces

Traces are enabled only in interrupt control mode 2. Trace mode is entered when the T bit of EXR is set to 1. When trace mode is established, trace exception handling starts at the end of each instruction.

At the end of a trace exception-handling sequence, the T bit of EXR is cleared to 0 and trace mode is cleared. Interrupt masks are not affected.

The T bit saved on the stack retains its value of 1, and when the RTE instruction is executed to return from the trace exception-handling routine, trace mode is entered again. Trace exception-handling is not executed at the end of the RTE instruction.

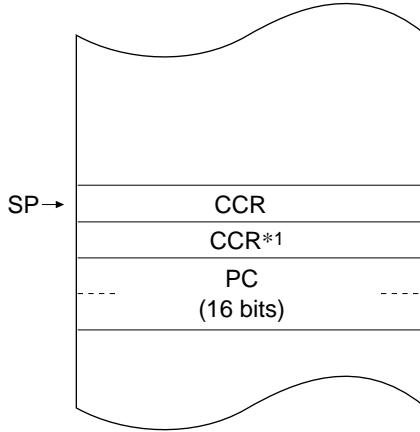
Trace mode is not entered in interrupt control mode 0, regardless of the state of the T bit.

## (4) Interrupt Exception Handling and Trap Instruction Exception Handling

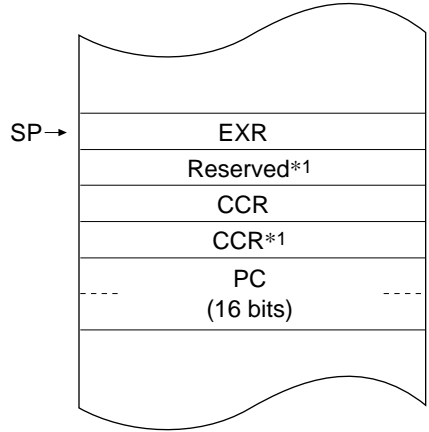
When interrupt or trap-instruction exception handling begins, the CPU references the stack pointer (ER7) and pushes the program counter and other control registers onto the stack. Next, the CPU alters the settings of the interrupt mask bits in the control registers. Then the CPU fetches a start address (vector) from the exception vector table and program execution starts from that start address.

Figure 2.16 shows the stack after exception handling ends.

Normal mode\*2

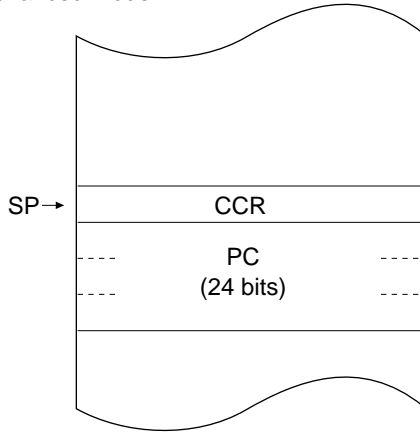


(a) Interrupt control mode 0

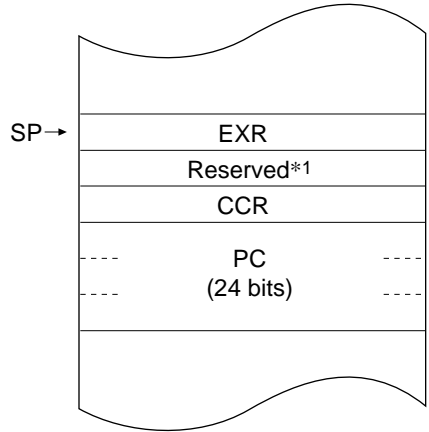


(b) Interrupt control mode 2

Advanced mode



(c) Interrupt control mode 0



(d) Interrupt control mode 2

Notes: \*1 Ignored when returning.  
\*2 Not available in the LSI.

**Figure 2.16 Stack Structure after Exception Handling (Examples)**

## 2.8.4 Program Execution State

In this state the CPU executes program instructions in sequence.

## 2.8.5 Bus-Released State

This is a state in which the bus has been released in response to a bus request from a bus master other than the CPU. While the bus is released, the CPU halts operations.

There is one other bus master in addition to the CPU: the data transfer controller (DTC).

For further details, refer to section 7, Bus Controller.

## 2.8.6 Power-Down State

The power-down state includes both modes in which the CPU stops operating and modes in which the CPU does not stop. There are five modes in which the CPU stops operating: sleep mode, software standby mode, hardware standby mode, subsleep mode, and watch mode. There are also three other power-down modes: medium-speed mode, module stop mode, and subactive mode. In medium-speed mode the CPU and other bus masters operate on a medium-speed clock. Module stop mode permits halting of the operation of individual modules, other than the CPU. Subactive mode, subsleep mode, and watch mode are power-down states in which subclock input is used. For details, refer to section 21, Power-Down State.

**(1) Sleep Mode:** A transition to sleep mode is made if the SLEEP instruction is executed while the SSBY bit in SBYCR and the LSON bit in LPWRCR are both cleared to 0. In sleep mode, CPU operations stop immediately after execution of the SLEEP instruction. The contents of CPU registers are retained.

**(2) Software Standby Mode:** A transition to software standby mode is made if the SLEEP instruction is executed while the SSBY bit in SBYCR is set to 1, and the LSON bit in LPWRCR and the PSS bit in TCSR (WDT1) are both cleared to 0. In software standby mode, the CPU and clock halt and all MCU operations stop. As long as a specified voltage is supplied, the contents of CPU registers and on-chip RAM are retained. The I/O ports also remain in their existing states.

**(3) Hardware Standby Mode:** A transition to hardware standby mode is made when the STBY pin goes low. In hardware standby mode, the CPU and clock halt and all MCU operations stop. The on-chip supporting modules are reset, but as long as a specified voltage is supplied, on-chip RAM contents are retained.

## 2.9 Basic Timing

### 2.9.1 Overview

The H8S/2000 CPU is driven by a system clock, denoted by the symbol  $\phi$ . The period from one rising edge of  $\phi$  to the next is referred to as a "state." The memory cycle or bus cycle consists of one, two, or three states. Different methods are used to access on-chip memory, on-chip supporting modules, and the external address space.

### 2.9.2 On-Chip Memory (ROM, RAM)

On-chip memory is accessed in one state. The data bus is 16 bits wide, permitting both byte and word transfer instruction. Figure 2.17 shows the on-chip memory access cycle. Figure 2.18 shows the pin states.

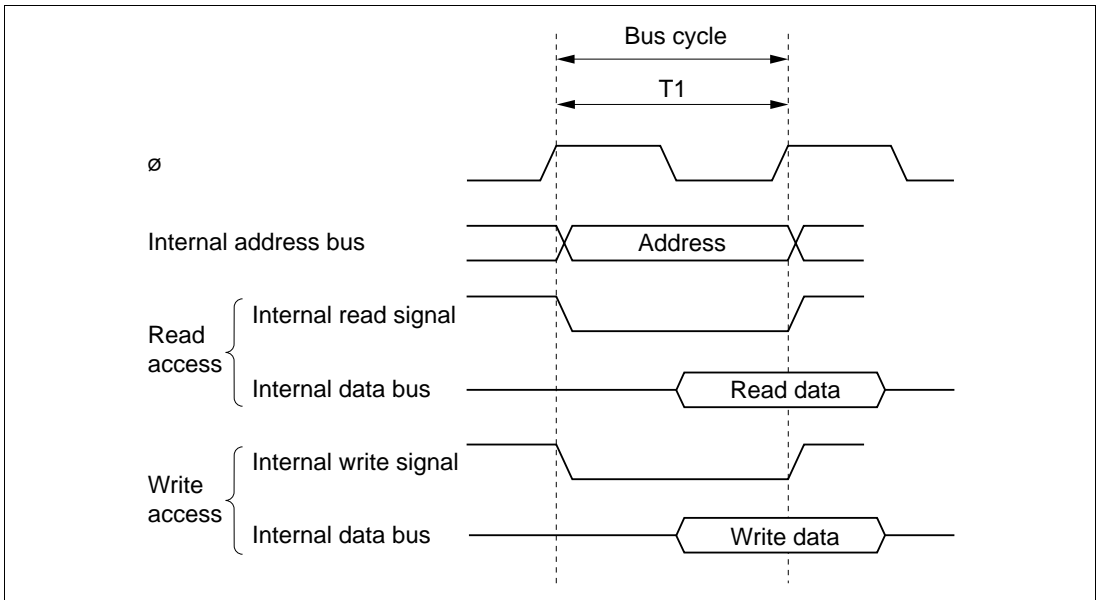
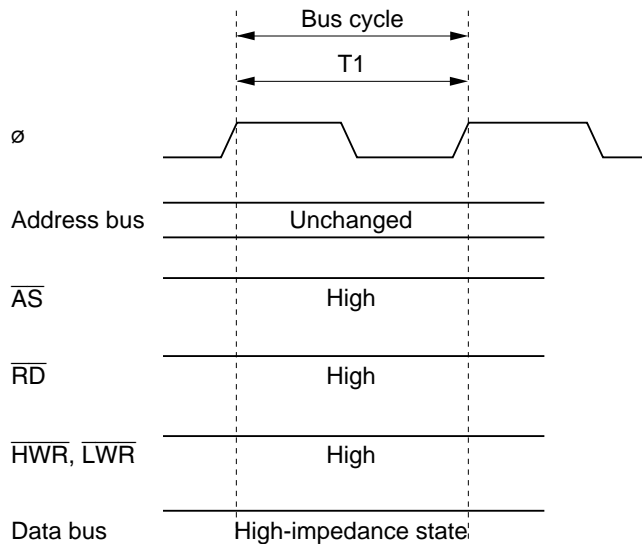


Figure 2.17 On-Chip Memory Access Cycle

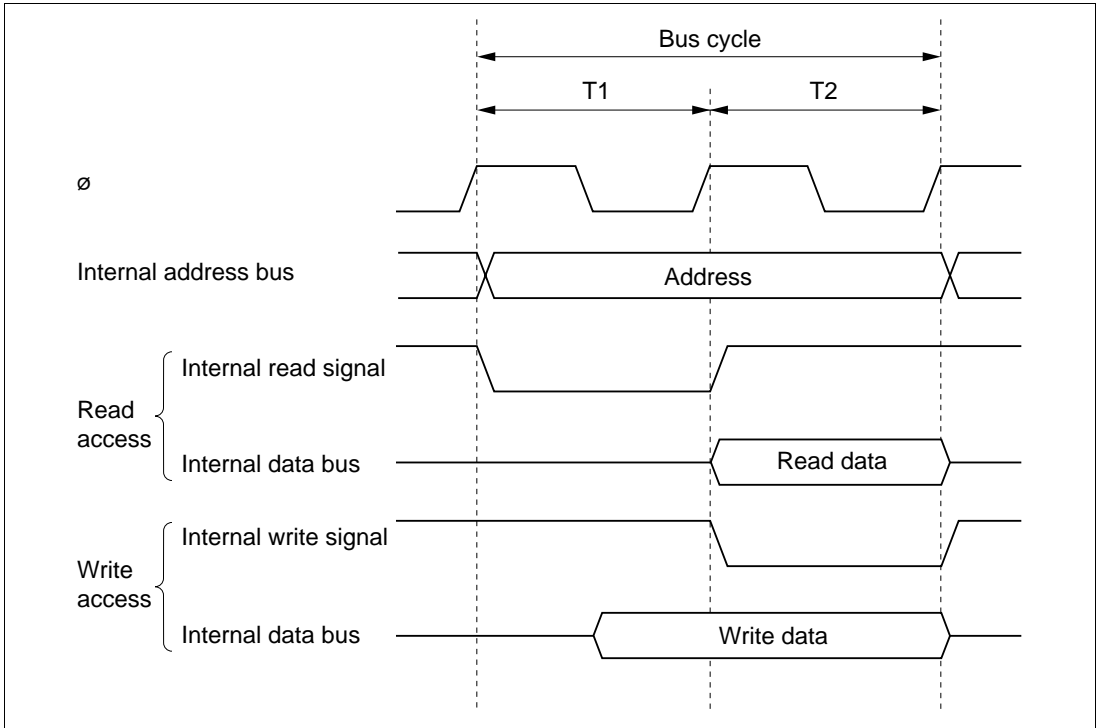




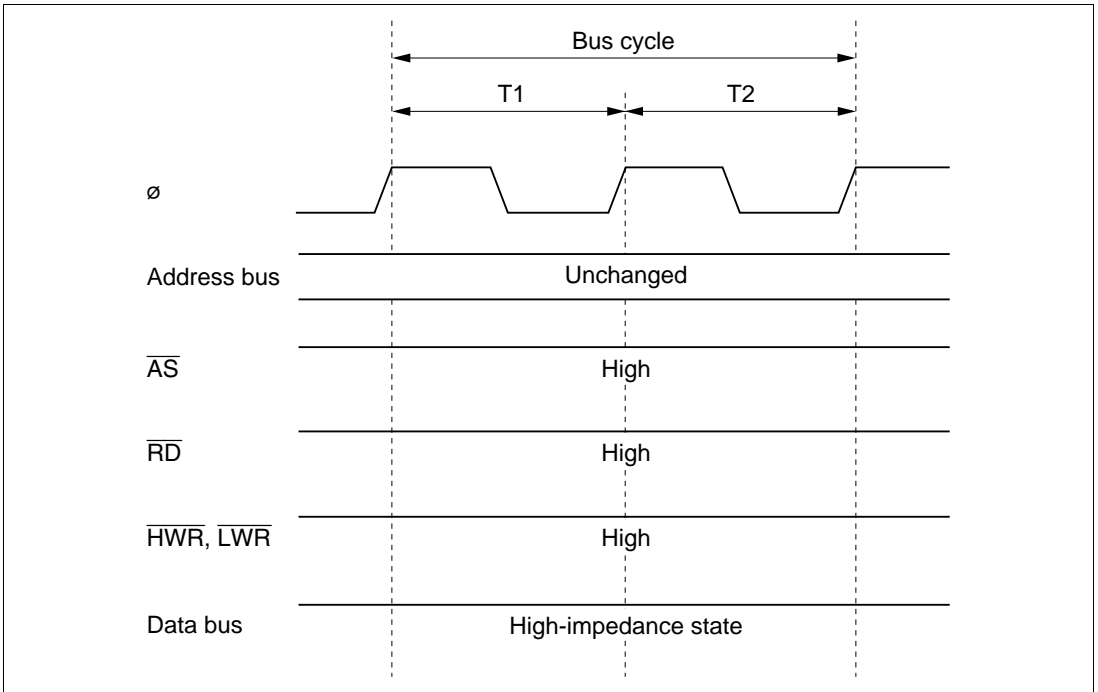
**Figure 2.18 Pin States during On-Chip Memory Access**

### 2.9.3 On-Chip Supporting Module Access Timing

The on-chip supporting modules are accessed in two states. The data bus is either 8 bits or 16 bits wide, depending on the particular internal I/O register being accessed. Figure 2.19 shows the access timing for the on-chip supporting modules. Figure 2.20 shows the pin states.



**Figure 2.19 On-Chip Supporting Module Access Cycle**



**Figure 2.20 Pin States during On-Chip Supporting Module Access**

#### 2.9.4 External Address Space Access Timing

The external address space is accessed with an 8-bit or 16-bit data bus width in a two-state or three-state bus cycle. In three-state access, wait states can be inserted. For further details, refer to section 7, Bus Controller.

## 2.10 Usage Note

Only register ER0, ER1, ER4, or ER5 should be used when using the TAS instruction. The TAS instruction is not generated by the Hitachi H8S and H8/300 series C/C++ compilers. If the TAS instruction is used as a user-defined intrinsic function, ensure that only register ER0, ER1, ER4, or ER5 is used.

### 2.10.1 STM/LDM Instruction

With the STM or LDM instruction, the ER7 register is used as the stack pointer, and thus cannot be used as a register that allows save (STM) or restore (LDM) operation.

With a single STM or LDM instruction, two to four registers can be saved or restored. The available registers are as follows:

- For two registers: ER0 and ER1, ER2 and ER3, or ER4 and ER5
- For three registers: ER0 to ER2, or ER4 to ER6
- For four registers: ER0 to ER3

For the Hitachi H8S or H8/300 Series C/C++ compiler, the STM/LDM instruction including ER7 is not created.

# Section 3 MCU Operating Modes

## 3.1 Overview

### 3.1.1 Operating Mode Selection

The LSI has four operating modes (modes 4 to 7). These modes enable selection of the CPU operating mode, enabling/disabling of on-chip ROM, and the initial bus width setting, by setting the mode pins (MD2 to MD0).

Table 3.1 lists the MCU operating modes.

**Table 3.1 MCU Operating Mode Selection**

MCU Operating Mode	MD2	MD1	MD0	CPU Operating Mode	Description	External Data Bus	
						On-Chip ROM	Initial Width
0*	0	0	0	—	—	—	—
1*			1				
2*		1	0				
3*			1				
4	1	0	0	Advanced	On-chip ROM disabled, Disabled expanded mode	16 bits	16 bits
5			1			8 bits	16 bits
6		1	0		On-chip ROM enabled, Enabled expanded mode	8 bits	16 bits
7			1		Single-chip mode	—	—

Note: \* Not available in the LSI.

The CPU's architecture allows for 4 Gbytes of address space, but the LSI actually accesses a maximum of 16 Mbytes.

Modes 4 to 6 are externally expanded modes that allow access to external memory and peripheral devices.

The external expansion modes allow switching between 8-bit and 16-bit bus modes. After program execution starts, an 8-bit or 16-bit address space can be set for each area, depending on the bus controller setting. If 16-bit access is selected for any one area, 16-bit bus mode is set; if 8-bit access is selected for all areas, 8-bit bus mode is set.

Note that the functions of each pin depend on the operating mode.

The LSI can be used only in modes 4 to 7. This means that the mode pins must be set to select one of these modes. Do not change the inputs at the mode pins during operation.

### 3.1.2 Register Configuration

The LSI has a mode control register (MDCR) that indicates the inputs at the mode pins (MD2 to MD0), and a system control register (SYSCR) that controls the operation of the LSI. Table 3.2 summarizes these registers.

**Table 3.2 MCU Registers**

Name	Abbreviation	R/W	Initial Value	Address*
Mode control register	MDCR	R	Undetermined	H'FDE7
System control register	SYSCR	R/W	H'01	H'FDE5

Note: \* Lower 16 bits of the address.

## 3.2 Register Descriptions

### 3.2.1 Mode Control Register (MDCR)

Bit	:	7	6	5	4	3	2	1	0
		—	—	—	—	—	MDS2	MDS1	MDS0
Initial value:		1	0	0	0	0	—*	—*	—*
R/W	:	—	—	—	—	—	R	R	R

Note: \* Determined by pins MD2 to MD0.

MDCR is an 8-bit read-only register that indicates the current operating mode of the LSI.

**Bit 7—Reserved:** This bit cannot be modified and is always read as 1.

**Bits 6 to 3—Reserved:** These bits cannot be modified and are always read as 0.

**Bits 2 to 0—Mode Select 2 to 0 (MDS2 to MDS0):** These bits indicate the input levels at pins MD2 to MD0 (the current operating mode). Bits MDS2 to MDS0 correspond to MD2 to MD0. MDS2 to MDS0 are read-only bits—they cannot be written to. The mode pin (MD2 to MD0) input levels are latched into these bits when MDCR is read. These latches are canceled by a power-on reset.

### 3.2.2 System Control Register (SYSCR)

Bit	:	7	6	5	4	3	2	1	0
		—	—	INTM1	INTM0	NMIEG	—	—	RAME
Initial value:		0	0	0	0	0	0	0	1
R/W	:	R/W	—	R/W	R/W	R/W	R/W	—	R/W

SYSCR is an 8-bit readable/writable register that selects the interrupt control mode, the detected edge for NMI, and enables or disables on-chip RAM.

SYSCR is initialized to H'01 by a power-on reset and in hardware standby mode. SYSCR is not initialized in software standby mode.

**Bit 7—Reserved:** Only 0 should be written to this bit.

**Bit 6—Reserved:** This bit cannot be modified and is always read as 0.

**Bits 5 and 4—Interrupt Control Mode 1 and 0 (INTM1, INTM0):** These bits select the control mode of the interrupt controller. For details of the interrupt control modes, see section 5.4.1, Interrupt Control Modes and Interrupt Operation.

Bit 5	Bit 4	Interrupt Control Mode	Description
INTM1	INTM0		
0	0	0	Control of interrupts by I bit (Initial value)
	1	—	Setting prohibited
1	0	2	Control of interrupts by I2 to I0 bits and IPR
	1	—	Setting prohibited

**Bit 3—NMI Edge Select (NMIEG):** Selects the valid edge of the NMI interrupt input.

#### Bit 3

NMIEG	Description
0	An interrupt is requested at the falling edge of NMI input (Initial value)
1	An interrupt is requested at the rising edge of NMI input

**Bit 2—Reserved:** Only 0 should be written to this bit.

**Bit 1—Reserved:** This bit cannot be modified and is always read as 0.

**Bit 0—RAM Enable (RAME):** Enables or disables the on-chip RAM. The RAME bit is initialized when the reset status is released. It is not initialized in software standby mode.

#### Bit 0

RAME	Description
0	On-chip RAM is disabled
1	On-chip RAM is enabled (Initial value)

Note: When the DTC is used, the RAME bit must be set to 1.

## 3.3 Operating Mode Descriptions

### 3.3.1 Mode 4

The CPU can access a 16-Mbyte address space in advanced mode. The on-chip ROM is disabled.

Pins P13 to P10, and ports A, B, and C function as an address bus, ports D and E function as a data bus, and part of port F carries bus control signals.

Pins P13 to P11 function as input ports immediately after a reset. Address (A23 to A21) output can be enabled or disabled by bits AE3 to AE0 in the pin function control register (PFCR) regardless of the corresponding data direction register (DDR) values. Pin 10 and ports A and B function as address (A20 to A8) outputs immediately after a reset. Address output can be enabled or disabled by bits AE3 to AE0 in PFCR regardless of the corresponding DDR values. Pins for which address output is disabled among pins P13 to P10 and in ports A and B become port outputs when the corresponding DDR bits are set to 1.

Port C always has an address (A7 to A0) output function.

The initial bus mode after a reset is 16 bits, with 16-bit access to all areas. However, note that if 8-bit access is designated by the bus controller for all areas, the bus mode switches to 8 bits.

### 3.3.2 Mode 5

The CPU can access a 16-Mbyte address space in advanced mode. The on-chip ROM is disabled.

Pins P13 to P10, and ports A, B, and C function as an address bus, ports D and E function as a data bus, and part of port F carries bus control signals.

Pins P13 to P11 function as input ports immediately after a reset. Address (A23 to A21) output can be enabled or disabled by bits AE3 to AE0 in the pin function control register (PFCR) regardless of the corresponding data direction register (DDR) values. Pin 10 and ports A and B function as address (A20 to A8) outputs immediately after a reset. Address output can be enabled



or disabled by bits AE3 to AE0 in PFCR regardless of the corresponding DDR values. Pins for which address output is disabled among pins P13 to P10 and in ports A and B become port outputs when the corresponding DDR bits are set to 1.

Port C always has an address (A7 to A0) output function.

The initial bus mode after a reset is 8 bits, with 8-bit access to all areas. However, note that if 16-bit access is designated by the bus controller for any area, the bus mode switches to 16 bits and port E becomes a data bus.

### **3.3.3 Mode 6**

The CPU can access a 16-Mbyte address space in advanced mode. The on-chip ROM is enabled.

Pins P13 to P10, and ports A and B function as input ports immediately after a reset. Address (A23 to A8) output can be enabled or disabled by bits AE3 to AE0 in the pin function control register (PFCR) regardless of the corresponding data direction register (DDR) values. Pins for which address output is disabled among pins P13 to P10 and in ports A and B become port outputs when the corresponding DDR bits are set to 1.

Ports D and E function as a data bus, and part of port F carries data bus signals.

Port C is an input port immediately after a reset. Addresses A7 to A0 are output by setting the corresponding DDR bits to 1.

The initial bus mode after a reset is 8 bits, with 8-bit access to all areas. However, note that if 16-bit access is designated by the bus controller for any area, the bus mode switches to 16 bits and port E becomes a data bus.

### **3.3.4 Mode 7**

The CPU can access a 16-Mbyte address space in advanced mode. The on-chip ROM is enabled, but external addresses cannot be accessed.

All I/O ports are available for use as input-output ports.

### 3.4 Pin Functions in Each Operating Mode

The pin functions of ports 1, and A to F vary depending on the operating mode. Table 3.3 shows their functions in each operating mode.

**Table 3.3 Pin Functions in Each Operating Mode**

Port		Mode 4	Mode 5	Mode 6	Mode 7
Port 1	P13 to P11	P*/A	P*/A	P*/A	P
	P10	P/A*	P/A*	P*/A	P
Port A	PA3 to PA0	P/A*	P/A*	P*/A	P
Port B		P/A*	P/A*	P*/A	P
Port C		A	A	P*/A	P
Port D		D	D	D	P
Port E		P/D*	P*/D	P*/D	P
Port F	PF7	P/C*	P/C*	P/C*	P*/C
	PF6 to PF4	C	C	C	P
	PF3	P/C*	P*/C	P*/C	
	PF2 to PF0	P*/C	P*/C	P*/C	

#### Legend

P: I/O port

A: Address bus output

D: Data bus I/O

C: Control signals, clock I/O

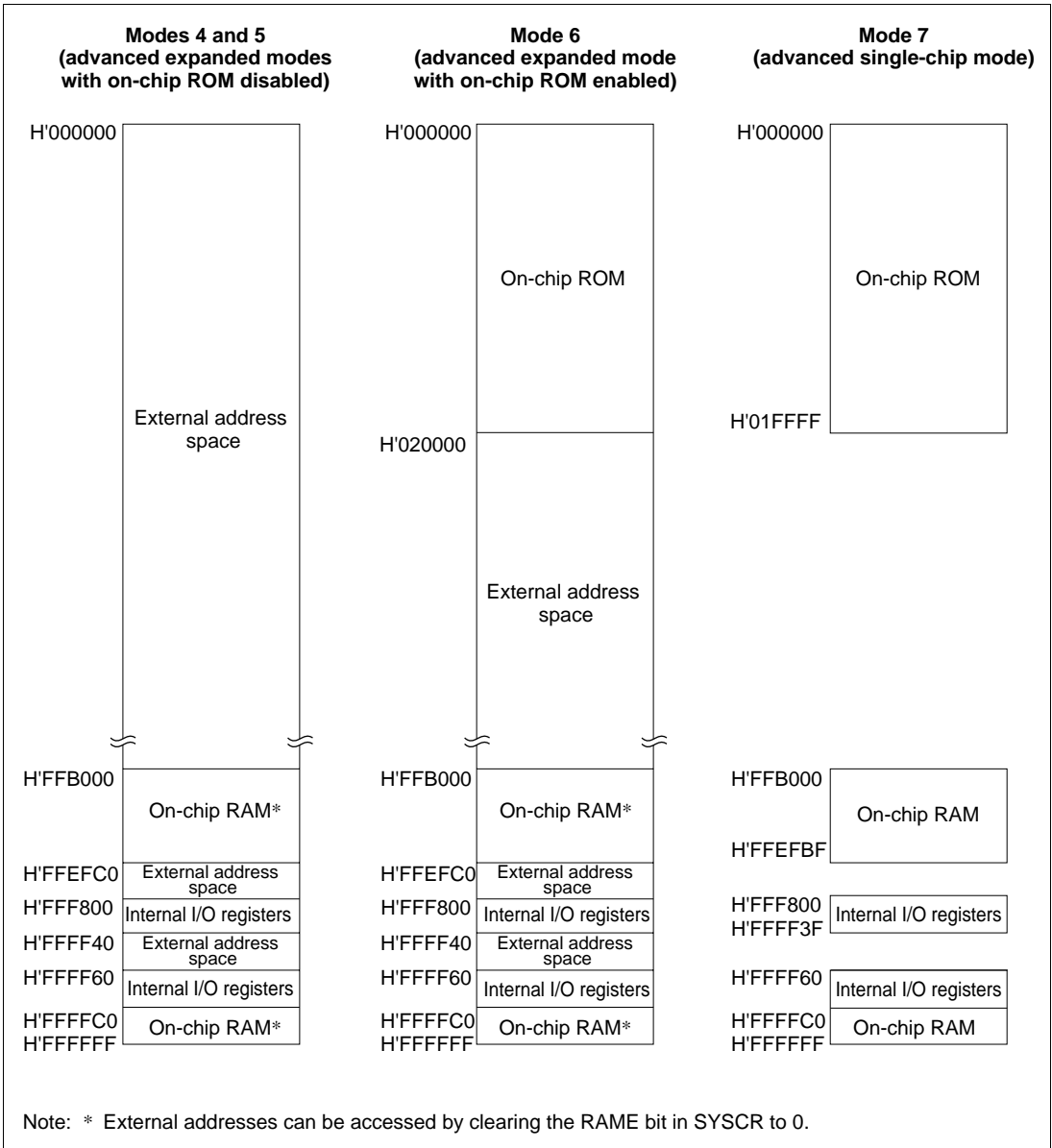
\*: After reset

### 3.5 Memory Map in Each Operating Mode

Figure 3.1 shows the memory map in each operating mode.

The address space is 16 Mbytes in modes 4 to 7 (advanced modes).

The address space is divided into eight areas for modes 4 to 7. For details, see section 7, Bus Controller.



**Figure 3.1 Memory Map in Each Operating Mode in the LSI**



# Section 4 Exception Handling

## 4.1 Overview

### 4.1.1 Exception Handling Types and Priority

As table 4.1 indicates, exception handling may be caused by a reset, trace, trap instruction, or interrupt. Exception handling is prioritized as shown in table 4.1. If two or more exceptions occur simultaneously, they are accepted and processed in order of priority. Trap instruction exceptions are accepted at all times, in the program execution state.

Exception handling sources, the stack structure, and the operation of the CPU vary depending on the interrupt control mode set by the INTM0 and INTM1 bits of SYSCR.

**Table 4.1 Exception Handling Types and Priority**

Priority	Exception Handling Type	Start of Exception Handling
High ↑	Reset	Starts immediately after a low-to-high transition at the $\overline{RES}$ pin, or when the watchdog timer overflows. The CPU enters the power-on reset state when the $\overline{RES}$ pin is low.
	Trace* <sup>1</sup>	Starts when execution of the current instruction or exception handling ends, if the trace (T) bit is set to 1
	Interrupt	Starts when execution of the current instruction or exception handling ends, if an interrupt request has been issued* <sup>2</sup>
Low	Trap instruction (TRAPA)* <sup>3</sup>	Started by execution of a trap instruction (TRAPA)

Notes: \*1 Traces are enabled only in interrupt control mode 2. Trace exception handling is not executed after execution of an RTE instruction.

\*2 Interrupt detection is not performed on completion of ANDC, ORC, XORC, or LDC instruction execution, or on completion of reset exception handling.

\*3 Trap instruction exception handling requests are accepted at all times in program execution state.

## 4.1.2 Exception Handling Operation

Exceptions originate from various sources. Trap instructions and interrupts are handled as follows:

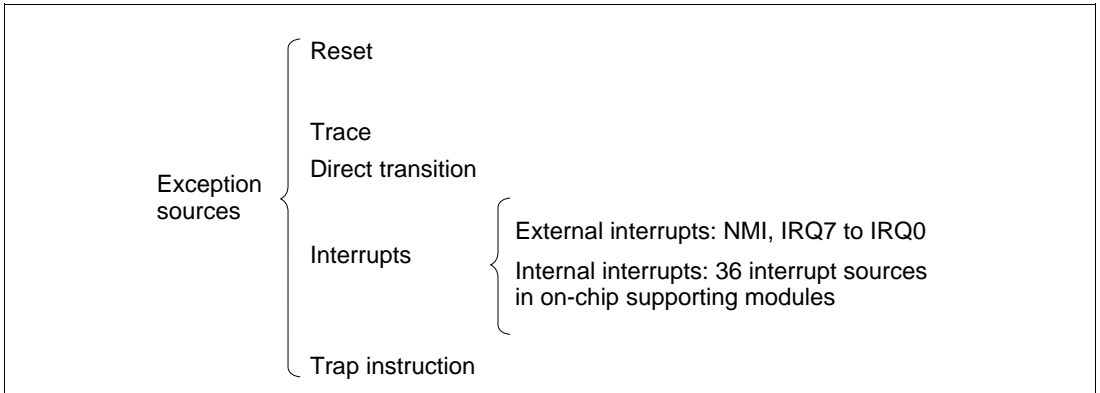
1. The program counter (PC), condition code register (CCR), and extended register (EXR) are pushed onto the stack.
2. The interrupt mask bits are updated. The T bit is cleared to 0.
3. A vector address corresponding to the exception source is generated, and program execution starts from that address.

For a reset exception, steps 2 and 3 above are carried out.

## 4.1.3 Exception Sources and Vector Table

The exception sources are classified as shown in figure 4.1. Different vector addresses are assigned to different exception sources.

Table 4.2 lists the exception sources and their vector addresses.



**Figure 4.1 Exception Sources**

**Table 4.2 Exception Vector Table**

Exception Source		Vector Number	Vector Address* <sup>1</sup>
			Advanced Mode
Power-on reset		0	H'0000 to H'0003
Reserved for system use		1	H'0004 to H'0007
		2	H'0008 to H'000B
		3	H'000C to H'000F
		4	H'0010 to H'0013
Trace		5	H'0014 to H'0017
Direct transition* <sup>3</sup>		6	H'0018 to H'001B
External interrupt	NMI	7	H'001C to H'001F
Trap instruction (4 sources)		8	H'0020 to H'0023
		9	H'0024 to H'0027
		10	H'0028 to H'002B
		11	H'002C to H'002F
Reserved for system use		12	H'0030 to H'0033
		13	H'0034 to H'0037
		14	H'0038 to H'003B
		15	H'003C to H'003F
External interrupt	IRQ0	16	H'0040 to H'0043
	IRQ1	17	H'0044 to H'0047
	IRQ2	18	H'0048 to H'004B
	IRQ3	19	H'004C to H'004F
	IRQ4	20	H'0050 to H'0053
	IRQ5	21	H'0054 to H'0057
	IRQ6	22	H'0058 to H'005B
	IRQ7	23	H'005C to H'005F
Internal interrupt* <sup>2</sup>		24	H'0060 to H'0063
		123	H'01EC to H'01EF

Notes: \*1 Lower 16 bits of the address.

\*2 For details of internal interrupt vectors, see section 5.3.3, Interrupt Exception Handling Vector Table.

\*3 For details of direct transition, see section 19.11, Direct Transition.

## 4.2 Reset

### 4.2.1 Overview

A reset has the highest exception priority.

When the  $\overline{\text{RES}}$  pin goes low, all processing halts and the LSI enters the reset state. A reset initializes the internal state of the CPU and the registers of on-chip supporting modules. Immediately after a reset, interrupt control mode 0 is set.

Reset exception handling begins when the  $\overline{\text{RES}}$  pin changes from low to high.

The LSI can also be reset by overflow of the watchdog timer. For details see section 12, Watchdog Timer.

### 4.2.2 Reset Sequence

The LSI enters the reset state when the  $\overline{\text{RES}}$  pin goes low.

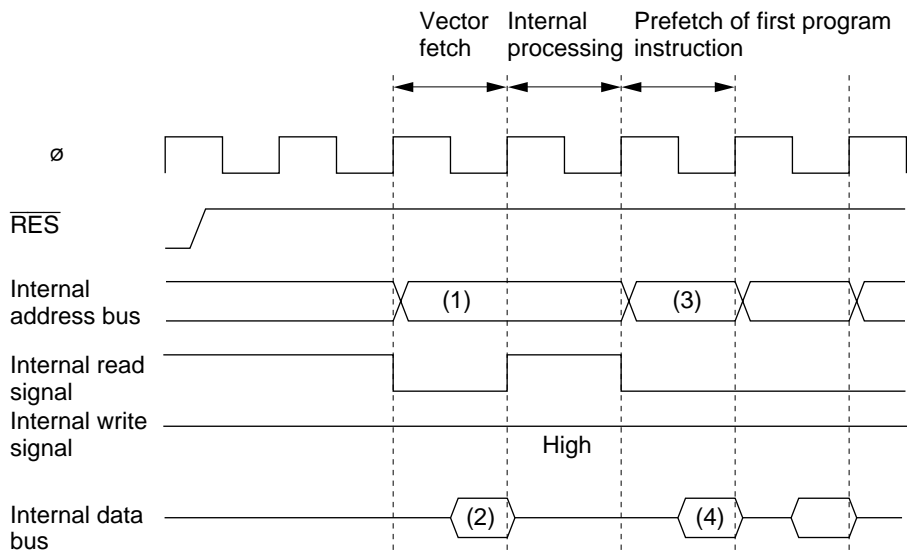
To ensure that the LSI is reset, hold the  $\overline{\text{RES}}$  pin low for at least 20 ms at power-up. To reset the LSI during operation, hold the  $\overline{\text{RES}}$  pin low for at least 20 states.

When the  $\overline{\text{RES}}$  pin goes high after being held low for the necessary time, the chip starts reset exception handling as follows:

1. The internal state of the CPU and the registers of the on-chip supporting modules are initialized, the T bit is cleared to 0 in EXR, and the I bit is set to 1 in EXR and CCR.
2. The reset exception handling vector address is read and transferred to the PC, and program execution starts from the address indicated by the PC.

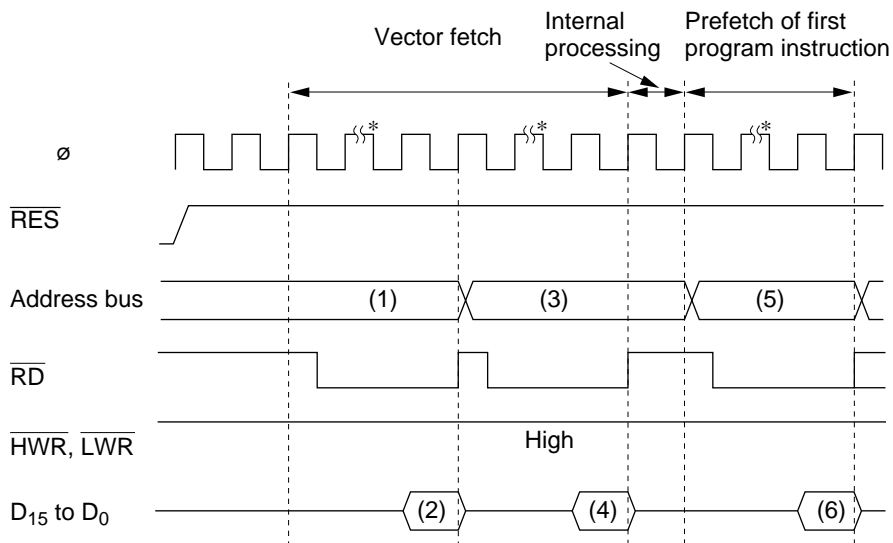
Figures 4.2 and 4.3 show examples of the reset sequence.





- (1) Reset exception handling vector address ((1) = H'0000)
- (2) Start address (contents of reset exception handling vector address)
- (3) Start address ((3) = (2))
- (4) First program instruction

**Figure 4.2 Reset Sequence (Modes 2 and 3: Not available in the LSI)**



- (1) (3) Reset exception handling vector address ((1) = H'000000, (3) = H'000002)  
 (2) (4) Start address (contents of reset exception handling vector address)  
 (5) Start address ((5) = (2) (4))  
 (6) First program instruction

Note: \* 3 program wait states are inserted.

**Figure 4.3 Reset Sequence (Mode 4)**

### 4.2.3 Interrupts after Reset

If an interrupt is accepted after a reset but before the stack pointer (SP) is initialized, the PC and CCR will not be saved correctly, leading to a program crash. To prevent this, all interrupt requests, including NMI, are disabled immediately after a reset. Since the first instruction of a program is always executed immediately after the reset state ends, make sure that this instruction initializes the stack pointer (example: `MOV.L #xx:32, SP`).

### 4.2.4 State of On-Chip Supporting Modules after Reset Release

After reset release, MSTPCRA is initialized to H'3F, MSTPCRB and MSTPCRC are initialized to H'FF, and all modules except the DTC enter module stop mode. Consequently, on-chip supporting module registers cannot be read or written to. Register reading and writing is enabled when module stop mode is exited.

## 4.3 Traces

Traces are enabled in interrupt control mode 2. Trace mode is not activated in interrupt control mode 0, irrespective of the state of the T bit. For details of interrupt control modes, see section 5, Interrupt Controller.

If the T bit in EXR is set to 1, trace mode is activated. In trace mode, a trace exception occurs on completion of each instruction.

Trace mode is canceled by clearing the T bit in EXR to 0. It is not affected by interrupt masking.

Table 4.4 shows the state of CCR and EXR after execution of trace exception handling.

Interrupts are accepted even within the trace exception handling routine.

The T bit saved on the stack retains its value of 1, and when control is returned from the trace exception handling routine by the RTE instruction, trace mode resumes.

Trace exception handling is not carried out after execution of the RTE instruction.

**Table 4.3 Status of CCR and EXR after Trace Exception Handling**

Interrupt Control Mode	CCR		EXR	
	I	UI	I2 to I0	T
0	Trace exception handling cannot be used.			
2	1	—	—	0

### Legend

1: Set to 1

0: Cleared to 0

—: Retains value prior to execution.

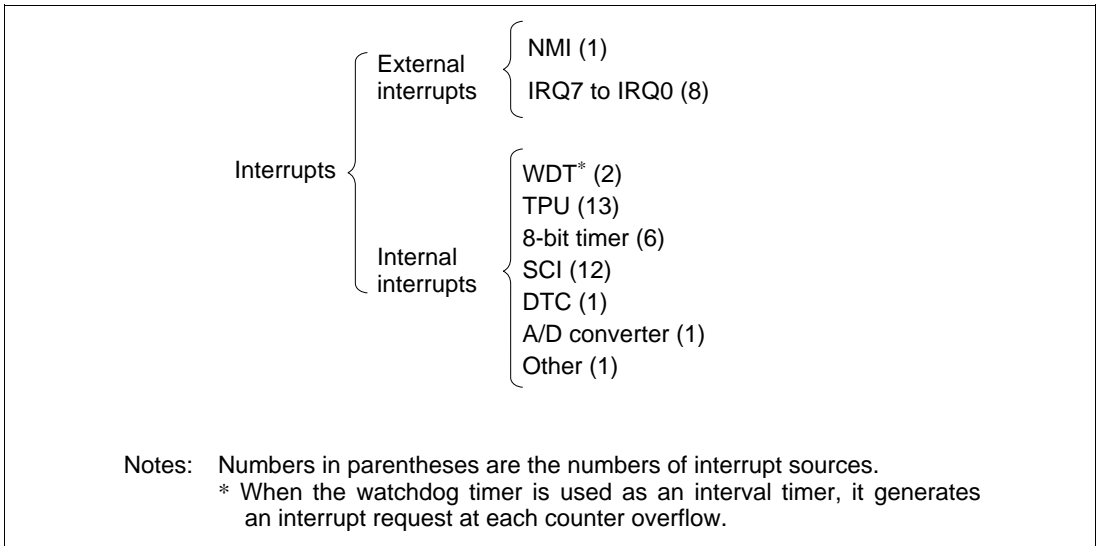
## 4.4 Interrupts

Interrupt exception handling can be requested by nine external sources (NMI, IRQ7 to IRQ0) and 36 internal sources in the on-chip supporting modules. Figure 4.4 classifies the interrupt sources and the number of interrupts of each type.

The on-chip supporting modules that can request interrupts include the watchdog timer (WDT), 16-bit timer-pulse unit (TPU), 8-bit timer, serial communication interface (SCI), data transfer controller (DTC), PC break controller (PBC) and A/D converter. Each interrupt source has a separate vector address.

NMI is the highest-priority interrupt. Interrupts are controlled by the interrupt controller. The interrupt controller has two interrupt control modes and can assign interrupts other than NMI to eight priority/mask levels to enable multiplexed interrupt control.

For details of interrupts, see section 5, Interrupt Controller.



**Figure 4.4 Interrupt Sources and Number of Interrupts**

## 4.5 Trap Instruction

Trap instruction exception handling starts when a TRAPA instruction is executed. Trap instruction exception handling can be executed at all times in the program execution state.

The TRAPA instruction fetches a start address from a vector table entry corresponding to a vector number from 0 to 3, as specified in the instruction code.

Table 4.4 shows the status of CCR and EXR after execution of trap instruction exception handling.

**Table 4.4 Status of CCR and EXR after Trap Instruction Exception Handling**

Interrupt Control Mode	CCR		EXR	
	I	UI	I2 to I0	T
0	1	—	—	—
2	1	—	—	0

### Legend

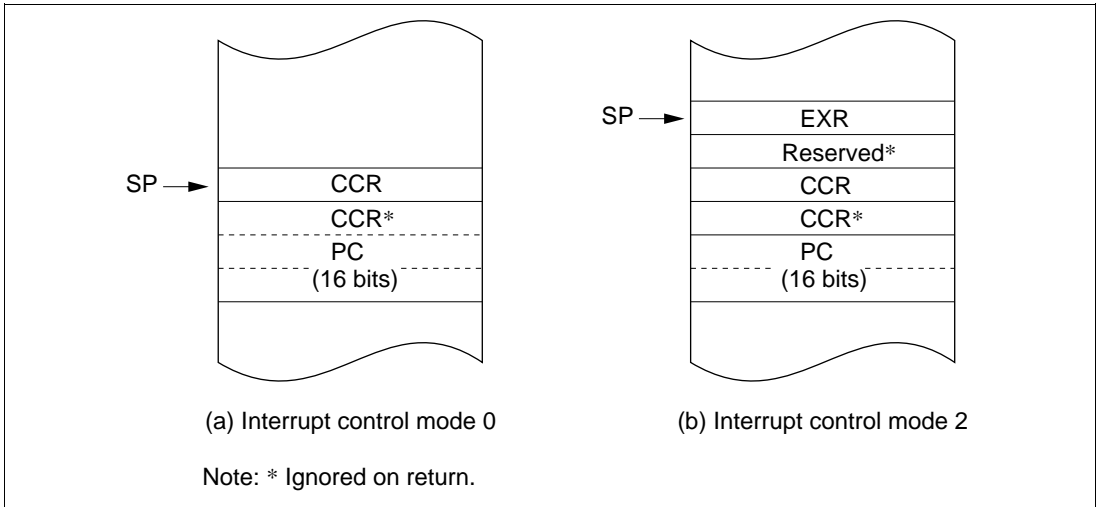
1: Set to 1

0: Cleared to 0

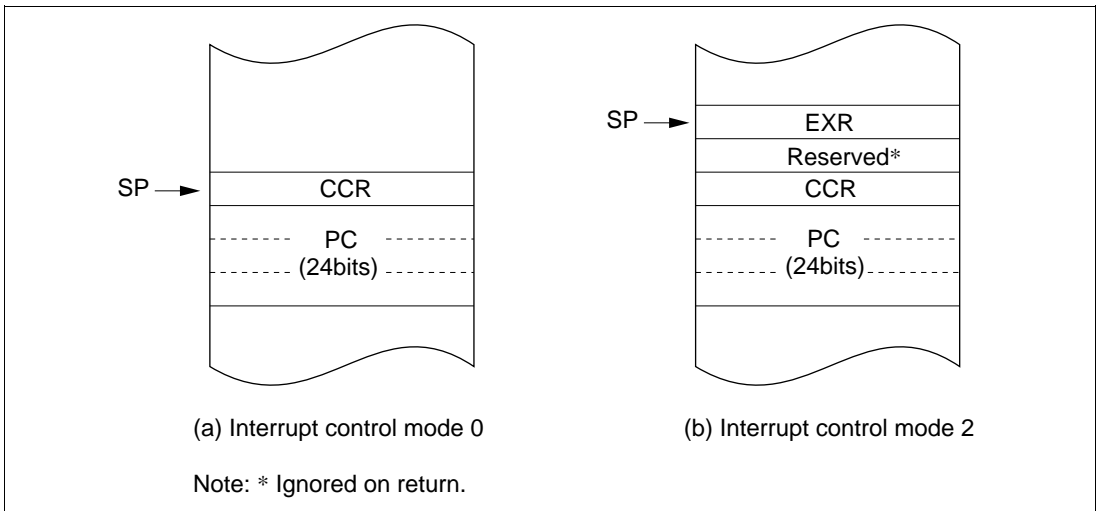
—: Retains value prior to execution.

## 4.6 Stack Status after Exception Handling

Figure 4.5 shows the stack after completion of trap instruction exception handling and interrupt exception handling.



**Figure 4.5 (1) Stack Status after Exception Handling (Normal Modes: Not available in the LSI)**



**Figure 4.5 (2) Stack Status after Exception Handling (Advanced Modes)**

## 4.7 Notes on Use of the Stack

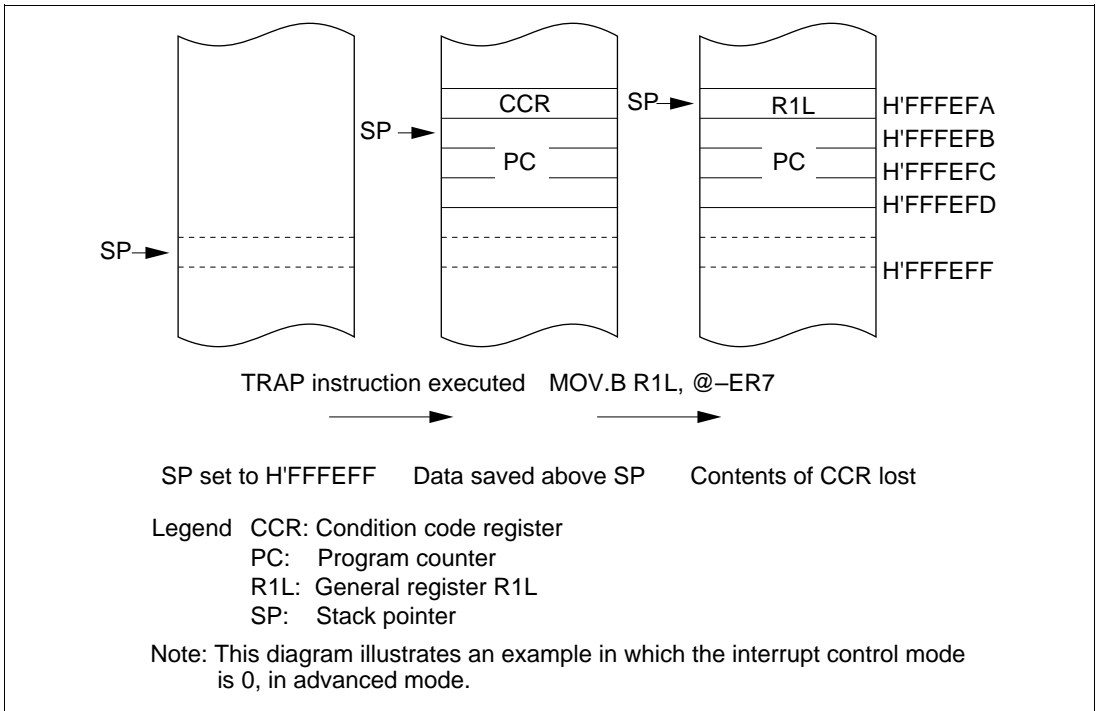
When accessing word data or longword data, the LSI assumes that the lowest address bit is 0. The stack should always be accessed by word transfer instruction or longword transfer instruction, and the value of the stack pointer (SP: ER7) should always be kept even. Use the following instructions to save registers:

```
PUSH.W  Rn    (or MOV.W Rn, @-SP)
PUSH.L  ERn   (or MOV.L ERn, @-SP)
```

Use the following instructions to restore registers:

```
POP.W   Rn    (or MOV.W @SP+, Rn)
POP.L   ERn   (or MOV.L @SP+, ERn)
```

Setting SP to an odd value may lead to a malfunction. Figure 4.6 shows an example of what happens when the SP value is odd.



**Figure 4.6 Operation when SP Value is Odd**





# Section 5 Interrupt Controller

## 5.1 Overview

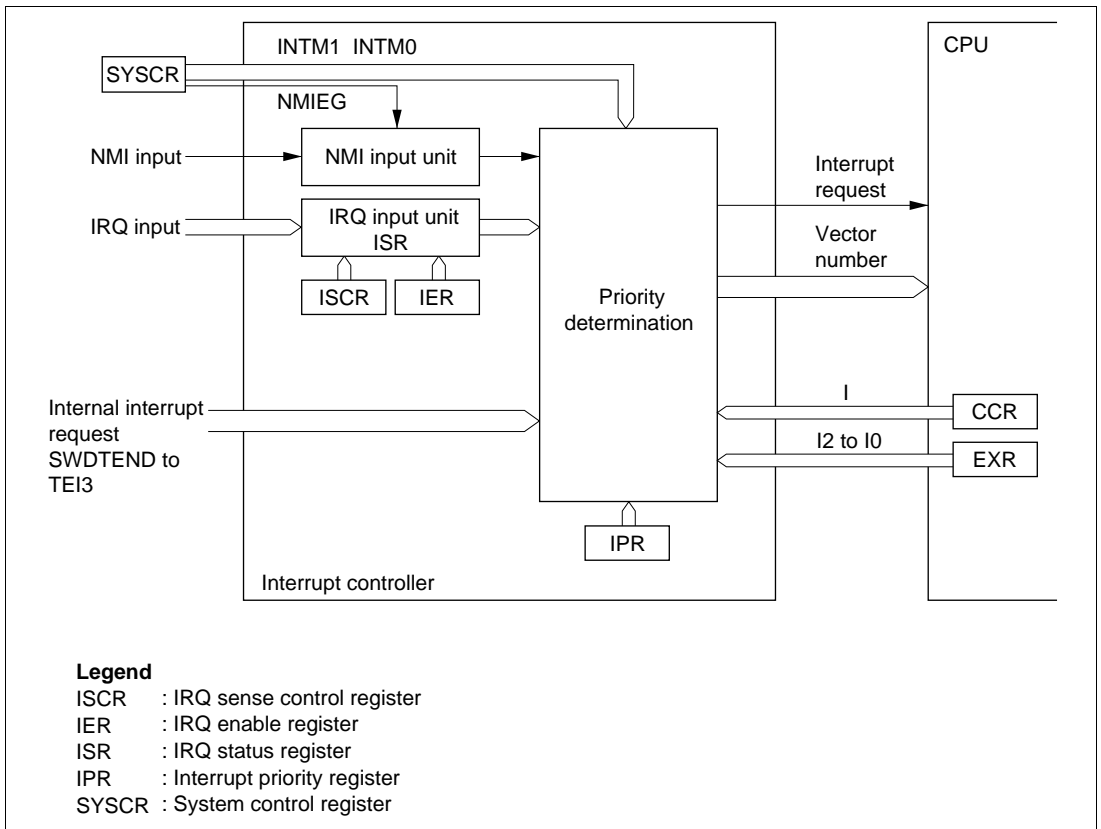
### 5.1.1 Features

The LSI controls interrupts by means of an interrupt controller. The interrupt controller has the following features:

- Two interrupt control modes
  - Any of two interrupt control modes can be set by means of the INTM1 and INTM0 bits in the system control register (SYSCR).
- Priorities settable with IPR
  - An interrupt priority register (IPR) is provided for setting interrupt priorities. Eight priority levels can be set for each module for all interrupts except NMI.
  - NMI is assigned the highest priority level of 8, and can be accepted at all times.
- Independent vector addresses
  - All interrupt sources are assigned independent vector addresses, making it unnecessary for the source to be identified in the interrupt handling routine.
- Nine external interrupts ( $\overline{\text{IRQ6}}$  is an interrupt only for the FLEX™ decoder II.)
  - NMI is the highest-priority interrupt, and is accepted at all times. Rising edge or falling edge can be selected for NMI.
  - Falling edge, rising edge, or both edge detection, or level sensing, can be selected for IRQ7 to IRQ0.
- DTC control
  - DTC activation is performed by means of interrupts.

## 5.1.2 Block Diagram

A block diagram of the interrupt controller is shown in Figure 5.1.



**Figure 5.1 Block Diagram of Interrupt Controller**

## 5.1.3 Pin Configuration

Table 5.1 summarizes the pins of the interrupt controller.

**Table 5.1 Interrupt Controller Pins**

Name	Symbol	I/O	Function
Nonmaskable interrupt	NMI	Input	Nonmaskable external interrupt; rising or falling edge can be selected
External interrupt requests 7 to 0	$\overline{IRQ7}$ to $\overline{IRQ0}$	Input	Maskable external interrupts; rising, falling, or both edges, or level sensing, can be selected ( $\overline{IRQ6}$ is a dedicated interrupt for the FLEX™ decoder II)

## 5.1.4 Register Configuration

Table 5.2 summarizes the registers of the interrupt controller.

**Table 5.2 Interrupt Controller Registers**

Name	Abbreviation	R/W	Initial Value	Address* <sup>1</sup>
System control register	SYSCR	R/W	H'01	H'FDE5
IRQ sense control register H	ISCRH	R/W	H'00	H'FE12
IRQ sense control register L	ISCR L	R/W	H'00	H'FE13
IRQ enable register	IER	R/W	H'00	H'FE14
IRQ status register	ISR	R/(W)* <sup>2</sup>	H'00	H'FE15
Interrupt priority register A	IPRA	R/W	H'77	H'FEC0
Interrupt priority register B	IPRB	R/W	H'77	H'FEC1
Interrupt priority register C	IPRC	R/W	H'77	H'FEC2
Interrupt priority register D	IPRD	R/W	H'77	H'FEC3
Interrupt priority register E	IPRE	R/W	H'77	H'FEC4
Interrupt priority register F	IPRF	R/W	H'77	H'FEC5
Interrupt priority register G	IPRG	R/W	H'77	H'FEC6
Interrupt priority register I	IPRI	R/W	H'77	H'FEC8
Interrupt priority register J	IPRJ	R/W	H'77	H'FEC9
Interrupt priority register K	IPRK	R/W	H'77	H'FECA
Interrupt priority register O	IPRO	R/W	H'77	H'FECE

Notes: \*1 Lower 16 bits of the address.

\*2 Can only be written with 0 for flag clearing.

## 5.2 Register Descriptions

### 5.2.1 System Control Register (SYSCR)

Bit	:	7	6	5	4	3	2	1	0
		—	—	INTM1	INTM0	NMIEG	—	—	RAME
Initial value:		0	0	0	0	0	0	0	1
R/W	:	R/W	—	R/W	R/W	R/W	R/W	—	R/W

SYSCR is an 8-bit readable/writable register that selects the interrupt control mode, and the detected edge for NMI.

Only bits 5 to 3 are described here; for details of the other bits, see section 3.2.2, System Control Register (SYSCR).

SYSCR is initialized to H'01 by a power-on reset and in hardware standby mode. SYSCR is not initialized in software standby mode.

**Bits 5 and 4—Interrupt Control Mode 1 and 0 (INTM1, INTM0):** These bits select one of two interrupt control modes for the interrupt controller.

Bit 5	Bit 4	Interrupt	
INTM1	INTM0	Control Mode	Description
0	0	0	Interrupts are controlled by I bit (Initial value)
	1	—	Setting prohibited
1	0	2	Interrupts are controlled by bits I2 to I0, and IPR
	1	—	Setting prohibited

**Bit 3—NMI Edge Select (NMIEG):** Selects the input edge for the NMI pin.

#### Bit 3

NMIEG	Description
0	Interrupt request generated at falling edge of NMI input (Initial value)
1	Interrupt request generated at rising edge of NMI input

## 5.2.2 Interrupt Priority Registers A to G, I to K, O (IPRA to IPRG, IPRI to IPRK, IPRO)

Bit	:	7	6	5	4	3	2	1	0
		—	IPR6	IPR5	IPR4	—	IPR2	IPR1	IPR0
Initial value:		0	1	1	1	0	1	1	1
R/W	:	—	R/W	R/W	R/W	—	R/W	R/W	R/W

The IPR registers are thirteen 8-bit readable/writable registers that set priorities (levels 7 to 0) for interrupts other than NMI.

The correspondence between IPR settings and interrupt sources is shown in table 5.3.

The IPR registers set a priority (level 7 to 0) for each interrupt source other than NMI.

The IPR registers are initialized to H'77 by a reset and in hardware standby mode.

They are not initialized in software standby mode.

**Bits 7 and 3—Reserved:** These bits cannot be modified and are always read as 0.

**Table 5.3 Correspondence between Interrupt Sources and IPR Settings**

Register	Bits	
	6 to 4	2 to 0
IPRA	IRQ0	IRQ1
IPRB	IRQ2	IRQ4
	IRQ3	IRQ5
IPRC	IRQ6	DTC
	IRQ7	
IPRD	Watchdog timer 0	—* <sup>1</sup>
IPRE	PC break	A/D converter, watchdog timer 1
IPRF	TPU channel 0	TPU channel 1
IPRG	TPU channel 2	—* <sup>2</sup>
IPRI	8-bit timer channel 0	8-bit timer channel 1
IPRJ	—* <sup>1</sup>	SCI channel 0
IPRK	SCI channel 1	—* <sup>2</sup>
IPRO	SCI channel 3	—* <sup>1</sup>

Notes: \*<sup>1</sup> Reserved bits. These bits cannot be modified and are always read as 1.

\*<sup>2</sup> Reserved bits. Only 1 may be written to these bits.

As shown in table 5.3, multiple interrupts are assigned to one IPR. Setting a value in the range from H'0 to H'7 in the 3-bit groups of bits 6 to 4 and 2 to 0 sets the priority of the corresponding interrupt. The lowest priority level, level 0, is assigned by setting H'0, and the highest priority level, level 7, by setting H'7.

When interrupt requests are generated, the highest-priority interrupt according to the priority levels set in the IPR registers is selected. This interrupt level is then compared with the interrupt mask level set by the interrupt mask bits (I2 to I0) in the extend register (EXR) in the CPU, and if the priority level of the interrupt is higher than the set mask level, an interrupt request is issued to the CPU.

### 5.2.3 IRQ Enable Register (IER)

Bit	:	7	6	5	4	3	2	1	0
		IRQ7E	IRQ6E	IRQ5E	IRQ4E	IRQ3E	IRQ2E	IRQ1E	IRQ0E
Initial value:		0	0	0	0	0	0	0	0
R/W	:	R/W	R/W	R/W	R/W	R/W	R/W	R/W	R/W

IER is an 8-bit readable/writable register that controls enabling and disabling of interrupt requests IRQ7 to IRQ0.

IER is initialized to H'00 by a reset and in hardware standby mode.

It is not initialized in software standby mode.

**Bits 7 to 0—IRQ7 to IRQ0 Enable (IRQ7E to IRQ0E):** These bits select whether IRQ7 to IRQ0 are enabled or disabled.

**Bit n**

IRQnE	Description
0	IRQn interrupts disabled (Initial value)
1	IRQn interrupts enabled

(n = 7 to 0)

### 5.2.4 IRQ Sense Control Registers H and L (ISCRH, ISCR L)

**ISCRH**

Bit	:	15	14	13	12	11	10	9	8
		IRQ7SCB	IRQ7SCA	IRQ6SCB	IRQ6SCA	IRQ5SCB	IRQ5SCA	IRQ4SCB	IRQ4SCA
Initial value:		0	0	0	0	0	0	0	0
R/W	:	R/W	R/W	R/W	R/W	R/W	R/W	R/W	R/W

**ISCR L**

Bit	:	7	6	5	4	3	2	1	0
		IRQ3SCB	IRQ3SCA	IRQ2SCB	IRQ2SCA	IRQ1SCB	IRQ1SCA	IRQ0SCB	IRQ0SCA
Initial value:		0	0	0	0	0	0	0	0
R/W	:	R/W	R/W	R/W	R/W	R/W	R/W	R/W	R/W

The ISCR registers are 16-bit readable/writable registers that select rising edge, falling edge, or both edge detection, or level sensing, for the input at pins  $\overline{\text{IRQ7}}$  to  $\overline{\text{IRQ0}}$ .

The ISCR registers are initialized to H'0000 by a reset and in hardware standby mode.

They are not initialized in software standby mode.

### Bits 15 to 0—IRQ7 Sense Control A and B (IRQ7SCA, IRQ7SCB) to IRQ0 Sense Control A and B (IRQ0SCA, IRQ0SCB)

#### Bits 15 to 0

IRQ7SCB to IRQ0SCB	IRQ7SCA to IRQ0SCA	Description
0	0	Interrupt request generated at $\overline{\text{IRQ7}}$ to $\overline{\text{IRQ0}}$ input low level (initial value)
	1	Interrupt request generated at falling edge of $\overline{\text{IRQ7}}$ to $\overline{\text{IRQ0}}$ input
1	0	Interrupt request generated at rising edge of $\overline{\text{IRQ7}}$ to $\overline{\text{IRQ0}}$ input
	1	Interrupt request generated at both falling and rising edges of $\overline{\text{IRQ7}}$ to $\overline{\text{IRQ0}}$ input

### 5.2.5 IRQ Status Register (ISR)

Bit	:	7	6	5	4	3	2	1	0
		IRQ7F	IRQ6F	IRQ5F	IRQ4F	IRQ3F	IRQ2F	IRQ1F	IRQ0F
Initial value:		0	0	0	0	0	0	0	0
R/W	:	R/(W)*	R/(W)*	R/(W)*	R/(W)*	R/(W)*	R/(W)*	R/(W)*	R/(W)*

Note: \* Only 0 can be written, to clear the flag.

ISR is an 8-bit readable/writable register that indicates the status of IRQ7 to IRQ0 interrupt requests.

ISR is initialized to H'00 by a reset and in hardware standby mode.

It is not initialized in software standby mode.

**Bits 7 to 0—IRQ7 to IRQ0 flags (IRQ7F to IRQ0F):** These bits indicate the status of IRQ7 to IRQ0 interrupt requests.

**Bit n**

IRQnF	Description	
0	[Clearing conditions]	(Initial value)
	<ul style="list-style-type: none"> <li>• Cleared by reading IRQnF flag when IRQnF = 1, then writing 0 to IRQnF flag</li> <li>• When interrupt exception handling is executed when low-level detection is set (IRQnSCB = IRQnSCA = 0) and <math>\overline{\text{IRQn}}</math> input is high</li> <li>• When IRQn interrupt exception handling is executed when falling, rising, or both-edge detection is set (IRQnSCB = 1 or IRQnSCA = 1)</li> <li>• When the DTC is activated by an IRQn interrupt, and the DISEL bit in MRB of the DTC is cleared to 0</li> </ul>	
1	[Setting conditions]	
	<ul style="list-style-type: none"> <li>• When <math>\overline{\text{IRQn}}</math> input goes low when low-level detection is set (IRQnSCB = IRQnSCA = 0)</li> <li>• When a falling edge occurs in <math>\overline{\text{IRQn}}</math> input when falling edge detection is set (IRQnSCB = 0, IRQnSCA = 1)</li> <li>• When a rising edge occurs in <math>\overline{\text{IRQn}}</math> input when rising edge detection is set (IRQnSCB = 1, IRQnSCA = 0)</li> <li>• When a falling or rising edge occurs in <math>\overline{\text{IRQn}}</math> input when both-edge detection is set (IRQnSCB = IRQnSCA = 1)</li> </ul>	
		(n = 7 to 0)

### 5.3 Interrupt Sources

Interrupt sources comprise external interrupts (NMI and IRQ7 to IRQ0) and internal interrupts (36 sources).

#### 5.3.1 External Interrupts

There are nine external interrupts: NMI and IRQ7 to IRQ0. These interrupts can be used to restore the LSI from software standby mode.

**NMI Interrupt:** NMI is the highest-priority interrupt, and is always accepted by the CPU regardless of the interrupt control mode or the status of the CPU interrupt mask bits. The NMIEG bit in SYSCR can be used to select whether an interrupt is requested at a rising edge or a falling edge on the NMI pin.

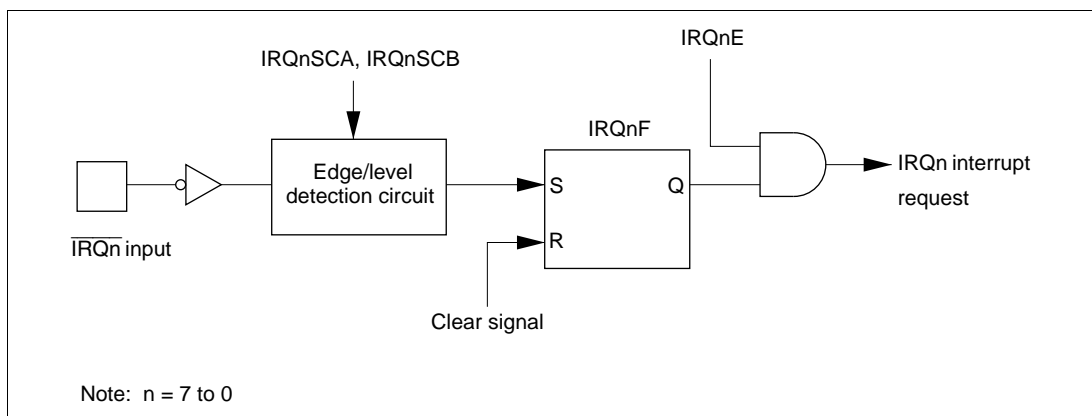
The vector number for NMI interrupt exception handling is 7.



**IRQ7 to IRQ0 Interrupts:** Interrupts IRQ7 to IRQ0 are requested by an input signal at pins  $\overline{\text{IRQ7}}$  to  $\overline{\text{IRQ0}}$ . Interrupts IRQ7 to IRQ0 have the following features:

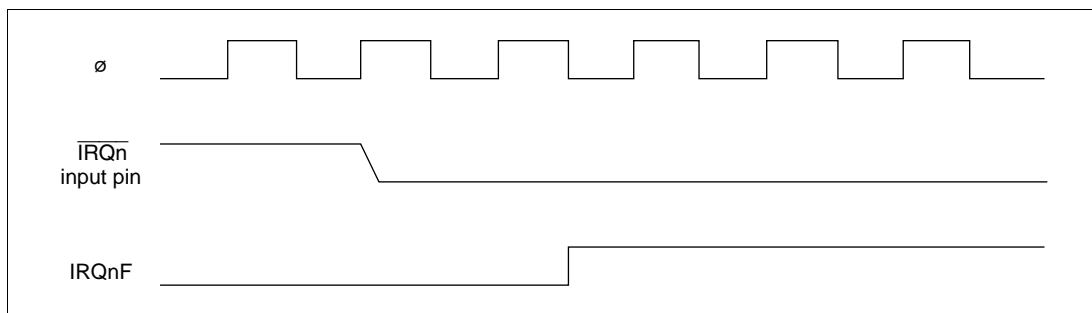
- Using ISCR, it is possible to select whether an interrupt is generated by a low level, falling edge, rising edge, or both edges, at pins  $\overline{\text{IRQ7}}$  to  $\overline{\text{IRQ0}}$ .
- Enabling or disabling of interrupt requests IRQ7 to IRQ0 can be selected with IER.
- The interrupt priority level can be set with IPR.
- The status of interrupt requests IRQ7 to IRQ0 is indicated in ISR. ISR flags can be cleared to 0 by software.

A block diagram of interrupts IRQ7 to IRQ0 is shown in figure 5.2.



**Figure 5.2 Block Diagram of Interrupts IRQ7 to IRQ0**

Figure 5.3 shows the timing of setting IRQnF.



**Figure 5.3 Timing of Setting IRQnF**

The vector numbers for IRQ7 to IRQ0 interrupt exception handling are 23 to 16.

Detection of IRQ7 to IRQ0 interrupts does not depend on whether the relevant pin has been set for input or output. However, when a pin is used as an external interrupt input pin, do not clear the

corresponding DDR to 0 and use the pin as an I/O pin for another function. Since interrupt request flags IRQ7F to IRQ0F are set when the setting condition is satisfied, regardless of the IER setting, only the necessary flags should be referenced.

### 5.3.2 Internal Interrupts

There are 36 sources for internal interrupts from on-chip supporting modules.

- For each on-chip supporting module there are flags that indicate the interrupt request status, and enable bits that select enabling or disabling of these interrupts. If both of these are set to 1 for a particular interrupt source, an interrupt request is issued to the interrupt controller.
- The interrupt priority level can be set by means of IPR.
- The DTC can be activated by a TPU, 8-bit timer, SCI, or other interrupt request. When the DTC is activated by an interrupt, the interrupt control mode and interrupt mask bits are not affected.

### 5.3.3 Interrupt Exception Handling Vector Table

Table 5.4 shows interrupt exception handling sources, vector addresses, and interrupt priorities. For default priorities, the lower the vector number, the higher the priority.

Priorities among modules can be set by means of the IPR. The situation when two or more modules are set to the same priority, and priorities within a module, are fixed as shown in table 5.4.

**Table 5.4 Interrupt Sources, Vector Addresses, and Interrupt Priorities**

Interrupt Source	Origin of Interrupt Source	Vector Number	Vector Address*	IPR	Priority
			Advanced Mode		
NMI	External pin	7	H'001C		High ↑
IRQ0		16	H'0040	IPRA6 to 4	
IRQ1		17	H'0044	IPRA2 to 0	
IRQ2		18	H'0048	IPRB6 to 4	
IRQ3		19	H'004C		
IRQ4		20	H'0050	IPRB2 to 0	
IRQ5		21	H'0054		
IRQ6 (dedicated to the FLEX™ decoder II)		22	H'0058	IPRC6 to 4	
IRQ7		23	H'005C		
SWDTEND (software activation interrupt end)		DTC	24	H'0060	
WOVI0 (interval timer 0)	Watchdog timer 0	25	H'0064	IPRD6 to 4	
PC break	PC break	27	H'006C	IPRE6 to 4	
ADI (A/D conversion end)	A/D	28	H'0070	IPRE2 to 0	
WOVI1 (interval timer 1)	Watchdog timer 1	29	H'0074		
Reserved	—	30	H'0078		
		31	H'007C		
TGIOA (TGR0A input capture/compare match)	TPU channel 0	32	H'0080	IPRF6 to 4	
TGIOB (TGR0B input capture/compare match)		33	H'0084		
TGIOC (TGR0C input capture/compare match)		34	H'0088		
TGIOD (TGR0D input capture/compare match)		35	H'008C		
TCIOV (overflow 0)		36	H'0090		
Reserved		—	37	H'0094	
	38		H'0098		
	39		H'009C		
					Low

Interrupt Source	Origin of Interrupt Source	Vector Number	Vector Address*	IPR	Priority
			Advanced Mode		
TGI1A (TGR1A input capture/compare match)	TPU channel 1	40	H'00A0	IPRF2 to 0	↑ High
TGI1B (TGR1B compare match)		41	H'00A4		
TCI1V (overflow 1)		42	H'00A8		
TCI1U (underflow 1)		43	H'00AC		
TGI2A (TGR2A input capture/compare match)	TPU channel 2	44	H'00B0	IPRG6 to 4	
TGI2B (TGR2B compare match)		45	H'00B4		
TCI2V (overflow 2)		46	H'00B8		
TCI2U (underflow 2)		47	H'00BC		
CMI A0 (compare match A)	8-bit timer channel 0	64	H'0100	IPRI6 to 4	
CMI B0 (compare match B)		65	H'0104		
OVI0 (overflow)		66	H'0108		
Reserved	—	67	H'010C		
CMI A1 (compare match A)	8-bit timer channel 1	68	H'0110	IPRI2 to 0	
CMI B1 (compare match B)		69	H'0114		
OVI1 (overflow)		70	H'0118		
Reserved	—	71	H'011C		
ERI0 (receive error 0)	SCI channel 0	80	H'0140	IPRJ2 to 0	
RXI0 (reception completed 0)		81	H'0144		
TXI0 (transmit data empty 0)		82	H'0148		
TEI0 (transmission end 0)		83	H'014C		
ERI1 (receive error 1)	SCI channel 1	84	H'0150	IPRK6 to 4	
RXI1 (reception completed 1)		85	H'0154		
TXI1 (transmit data empty 1)		86	H'0158		
TEI1 (transmission end 1)		87	H'015C		
ERI3 (receive error 3)	SCI channel 3	120	H'01E0	IPRO6 to 4	
RXI3 (reception completed 3)		121	H'01E4		
TXI3 (transmit data empty 3)		122	H'01E8		
TEI3 (transmission end 3)		123	H'01EC		
					Low

Note: \* Lower 16 bits of the start address.

## 5.4 Interrupt Operation

### 5.4.1 Interrupt Control Modes and Interrupt Operation

Interrupt operations in the LSI differ depending on the interrupt control mode.

NMI interrupts are accepted at all times except in the reset state and the hardware standby state. In the case of IRQ interrupts and on-chip supporting module interrupts, an enable bit is provided for each interrupt. Clearing an enable bit to 0 disables the corresponding interrupt request. Interrupt sources for which the enable bits are set to 1 are controlled by the interrupt controller.

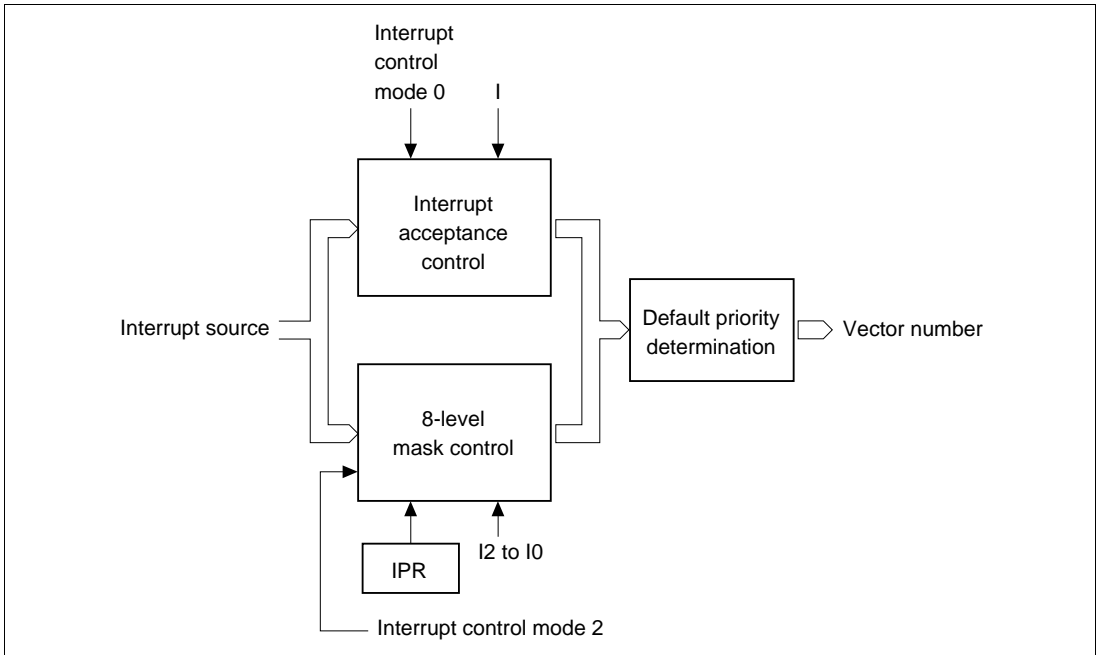
Table 5.5 shows the interrupt control modes.

The interrupt controller performs interrupt control according to the interrupt control mode set by the INTM1 and INTM0 bits in SYSCR, the priorities set in IPR, and the masking state indicated by the I and UI bits in the CPU's CCR, and bits I2 to I0 in EXR.

**Table 5.5 Interrupt Control Modes**

Interrupt Control Mode	SYSCR		Priority Setting Registers	Interrupt Mask Bits	Description
	INTM1	INTM0			
0	0	0	—	I	Interrupt mask control is performed by the I bit.
—	—	1	—	—	Setting prohibited
2	1	0	IPR	I2 to I0	8-level interrupt mask control is performed by bits I2 to I0. 8 priority levels can be set with IPR.
—	—	1	—	—	Setting prohibited

Figure 5.4 shows a block diagram of the priority decision circuit.



**Figure 5.4 Block Diagram of Interrupt Control Operation**

### (1) Interrupt Acceptance Control

In interrupt control mode 0, interrupt acceptance is controlled by the I bit in CCR.

Table 5.6 shows the interrupts selected in each interrupt control mode.

**Table 5.6 Interrupts Selected in Each Interrupt Control Mode (1)**

Interrupt Control Mode	Interrupt Mask Bits	
	I	Selected Interrupts
0	0	All interrupts
	1	NMI interrupts
2	*	All interrupts

\* : Don't care

## (2) 8-Level Control

In interrupt control mode 2, 8-level mask level determination is performed for the selected interrupts in interrupt acceptance control according to the interrupt priority level (IPR).

The interrupt source selected is the interrupt with the highest priority level, and whose priority level set in IPR is higher than the mask level.

**Table 5.7 Interrupts Selected in Each Interrupt Control Mode (2)**

Interrupt Control Mode	Selected Interrupts
0	All interrupts
2	Highest-priority-level (IPR) interrupt whose priority level is greater than the mask level (IPR > I2 to I0).

## (3) Default Priority Determination

When an interrupt is selected by 8-level control, its priority is determined and a vector number is generated.

If the same value is set for IPR, acceptance of multiple interrupts is enabled, and so only the interrupt source with the highest priority according to the preset default priorities is selected and has a vector number generated.

Interrupt sources with a lower priority than the accepted interrupt source are held pending.

Table 5.8 shows operations and control signal functions in each interrupt control mode.

**Table 5.8 Operations and Control Signal Functions in Each Interrupt Control Mode**

Interrupt Control Mode	Setting		Interrupt Acceptance Control		8-Level Control			Default Priority Determination	T (Trace)
	INTM1	INTM0	I	IM	I2 to I0	IPR	PR		
0	0	0	○	IM	X	—	—*2	○	—
2	1	0	X	—*1	○	IM	PR	○	T

### Legend

- : Interrupt operation control performed
- X : No operation. (All interrupts enabled)
- IM : Used as interrupt mask bit
- PR : Sets priority.
- : Not used.

Notes: \*1 Set to 1 when interrupt is accepted.

\*2 Keep the initial setting.

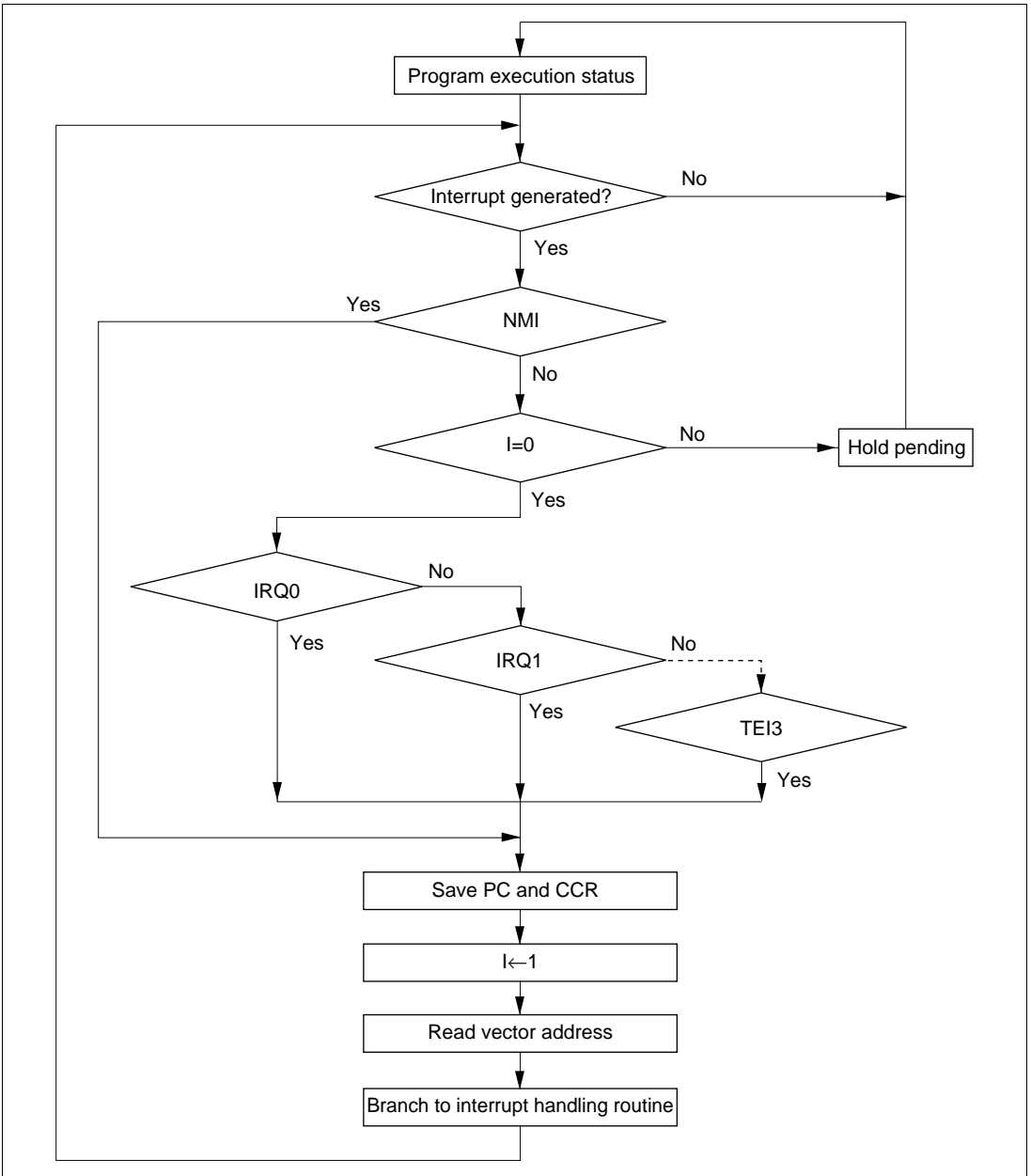
## 5.4.2 Interrupt Control Mode 0

Enabling and disabling of IRQ interrupts and on-chip supporting module interrupts can be set by means of the I bit in the CPU's CCR. Interrupts are enabled when the I bit is cleared to 0, and disabled when set to 1.

Figure 5.5 shows a flowchart of the interrupt acceptance operation in this case.

- [1] If an interrupt source occurs when the corresponding interrupt enable bit is set to 1, an interrupt request is sent to the interrupt controller.
- [2] The I bit is then referenced. If the I bit is cleared to 0, the interrupt request is accepted. If the I bit is set to 1, only an NMI interrupt is accepted, and other interrupt requests are held pending.
- [3] Interrupt requests are sent to the interrupt controller, the highest-ranked interrupt according to the priority system is accepted, and other interrupt requests are held pending.
- [4] When an interrupt request is accepted, interrupt exception handling starts after execution of the current instruction has been completed.
- [5] The PC and CCR are saved to the stack area by interrupt exception handling. The PC saved on the stack shows the address of the first instruction to be executed after returning from the interrupt handling routine.
- [6] Next, the I bit in CCR is set to 1. This masks all interrupts except NMI.
- [7] A vector address is generated for the accepted interrupt, and execution of the interrupt handling routine starts at the address indicated by the contents of that vector address.





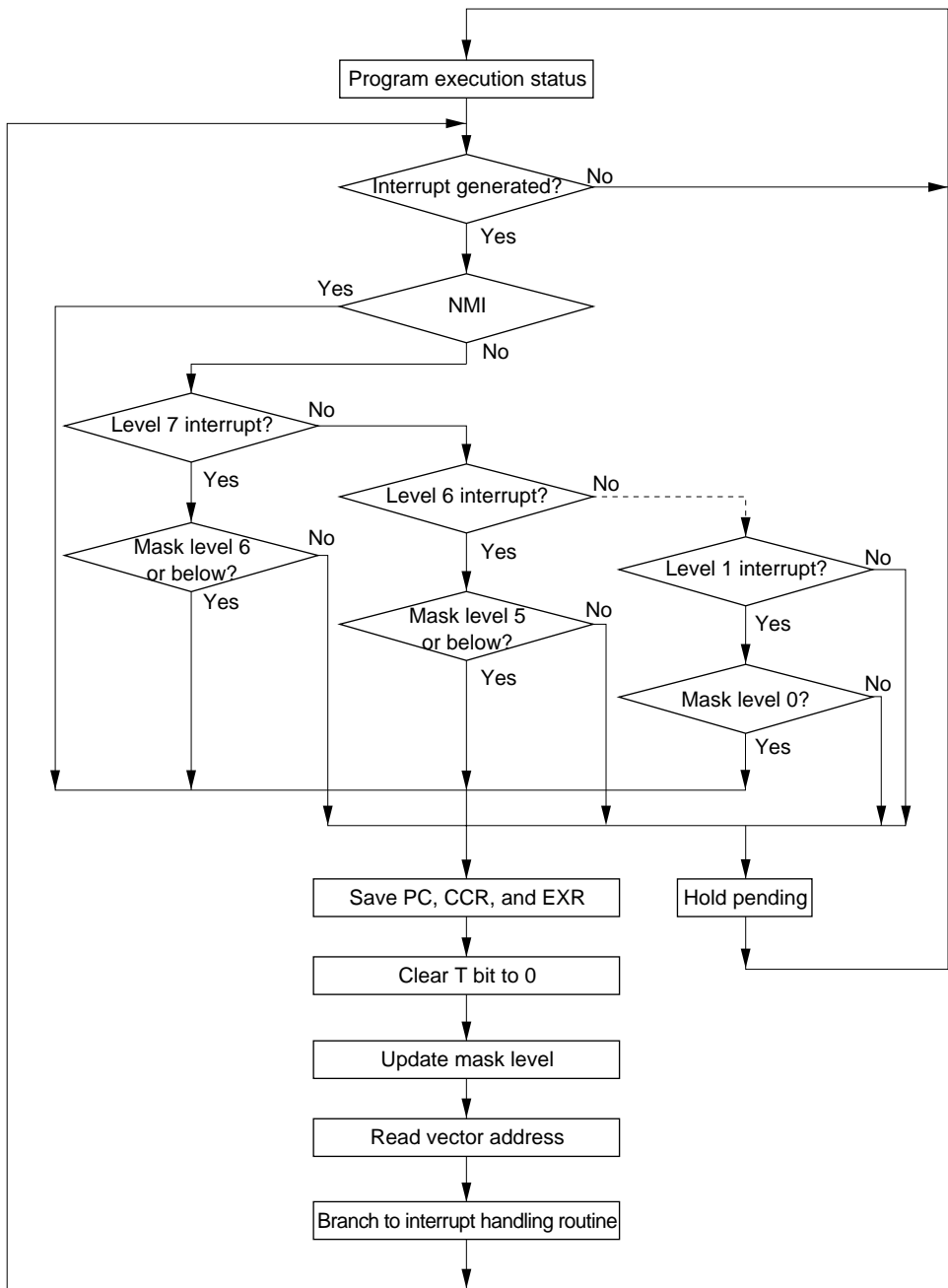
**Figure 5.5** Flowchart of Procedure Up to Interrupt Acceptance in Interrupt Control Mode 0

### 5.4.3 Interrupt Control Mode 2

Eight-level masking is implemented for IRQ interrupts and on-chip supporting module interrupts by comparing the interrupt mask level set by bits I2 to I0 of EXR in the CPU with IPR.

Figure 5.6 shows a flowchart of the interrupt acceptance operation in this case.

- [1] If an interrupt source occurs when the corresponding interrupt enable bit is set to 1, an interrupt request is sent to the interrupt controller.
- [2] When interrupt requests are sent to the interrupt controller, the interrupt with the highest priority according to the interrupt priority levels set in IPR is selected, and lower-priority interrupt requests are held pending. If a number of interrupt requests with the same priority are generated at the same time, the interrupt request with the highest priority according to the priority system shown in table 5.4 is selected.
- [3] Next, the priority of the selected interrupt request is compared with the interrupt mask level set in EXR. An interrupt request with a priority no higher than the mask level set at that time is held pending, and only an interrupt request with a priority higher than the interrupt mask level is accepted.
- [4] When an interrupt request is accepted, interrupt exception handling starts after execution of the current instruction has been completed.
- [5] The PC, CCR, and EXR are saved to the stack area by interrupt exception handling. The PC saved on the stack shows the address of the first instruction to be executed after returning from the interrupt handling routine.
- [6] The T bit in EXR is cleared to 0. The interrupt mask level is rewritten with the priority level of the accepted interrupt.  
If the accepted interrupt is NMI, the interrupt mask level is set to H'7.
- [7] A vector address is generated for the accepted interrupt, and execution of the interrupt handling routine starts at the address indicated by the contents of that vector address.



**Figure 5.6 Flowchart of Procedure Up to Interrupt Acceptance in Interrupt Control Mode 2**

## 5.4.4 Interrupt Exception Handling Sequence

Figure 5.7 shows the interrupt exception handling sequence. The example shown is for the case where interrupt control mode 0 is set in advanced mode, and the program area and stack area are in on-chip memory.

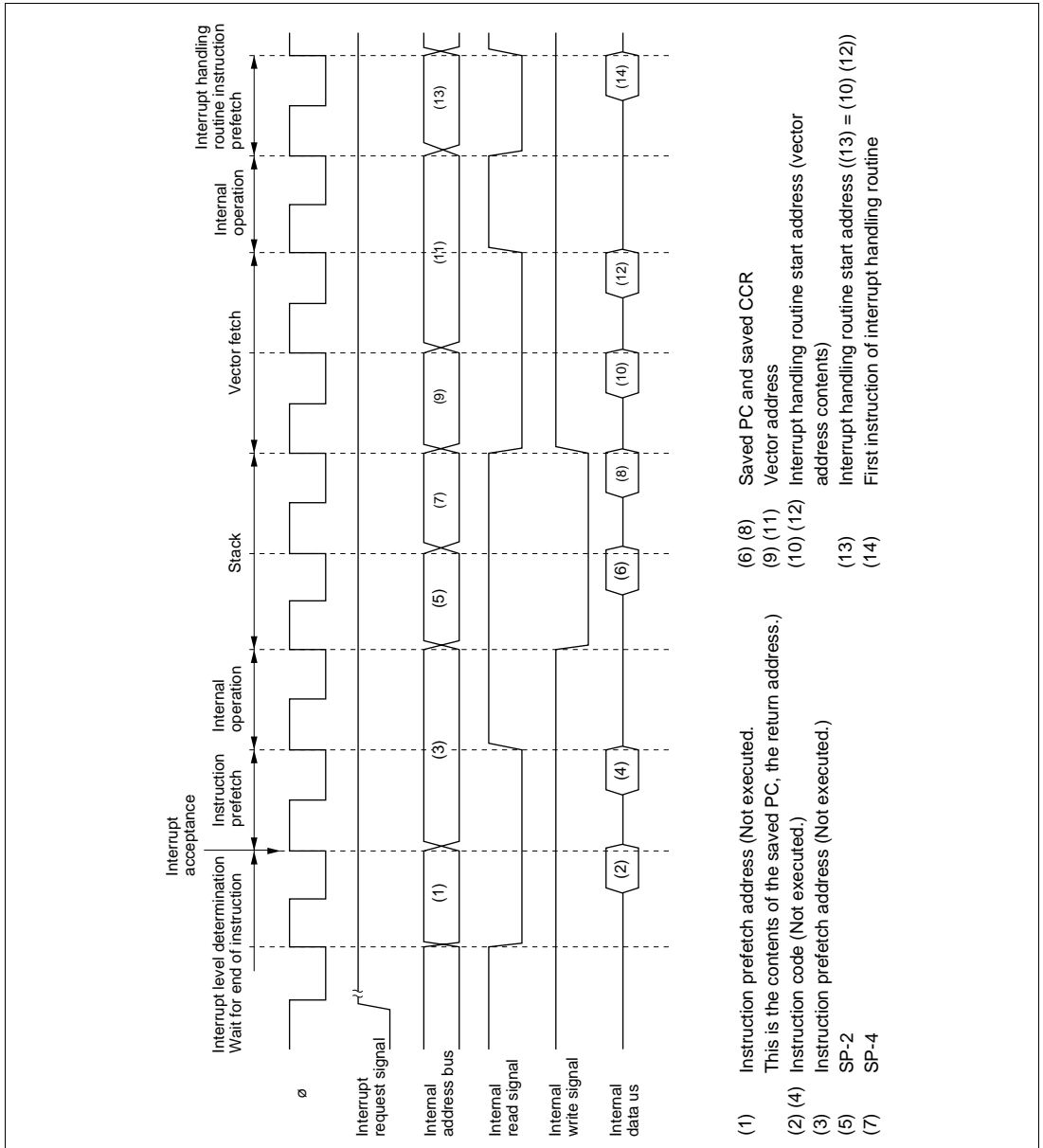


Figure 5.7 Interrupt Exception Handling

## 5.4.5 Interrupt Response Times

The LSI is capable of fast word transfer instruction to on-chip memory, and the program area is provided in on-chip ROM and the stack area in on-chip RAM, enabling high-speed processing.

Table 5.9 shows interrupt response times - the interval between generation of an interrupt request and execution of the first instruction in the interrupt handling routine. The execution status symbols used in table 5.9 are explained in table 5.10.

**Table 5.9 Interrupt Response Times**

No.	Execution Status	Normal Mode* <sup>5</sup>		Advanced Mode	
		INTM1 = 0	INTM1 = 1	INTM1 = 0	INTM1 = 1
1	Interrupt priority determination* <sup>1</sup>	3	3	3	3
2	Number of wait states until executing instruction ends* <sup>2</sup>	(1 to 19) +2·S <sub>I</sub>	(1 to 19) +2·S <sub>I</sub>	(1 to 19) +2·S <sub>I</sub>	(1 to 19) +2·S <sub>I</sub>
3	PC, CCR, EXR stack save	2·S <sub>K</sub>	3·S <sub>K</sub>	2·S <sub>K</sub>	3·S <sub>K</sub>
4	Vector fetch	S <sub>I</sub>	S <sub>I</sub>	2·S <sub>I</sub>	2·S <sub>I</sub>
5	Instruction fetch* <sup>3</sup>	2·S <sub>I</sub>	2·S <sub>I</sub>	2·S <sub>I</sub>	2·S <sub>I</sub>
6	Internal processing* <sup>4</sup>	2	2	2	2
Total (using on-chip memory)		11 to 31	12 to 32	12 to 32	13 to 33

Notes: \*1 Two states in case of internal interrupt.

\*2 Refers to MULXS and DIVXS instructions.

\*3 Prefetch after interrupt acceptance and interrupt handling routine prefetch.

\*4 Internal processing after interrupt acceptance and internal processing after vector fetch.

\*5 Not available in the LSI.

**Table 5.10 Number of States in Interrupt Handling Routine Execution Statuses**

Symbol		Object of Access				
		Internal Memory	External Device		3-State Access	
			8 Bit Bus 2-State Access	16 Bit Bus 2-State Access		
Instruction fetch	S <sub>I</sub>	1	4	6+2m	2	3+m
Branch address read	S <sub>J</sub>					
Stack manipulation	S <sub>K</sub>					

m: Number of wait states in an external device access.

## 5.5 Usage Notes

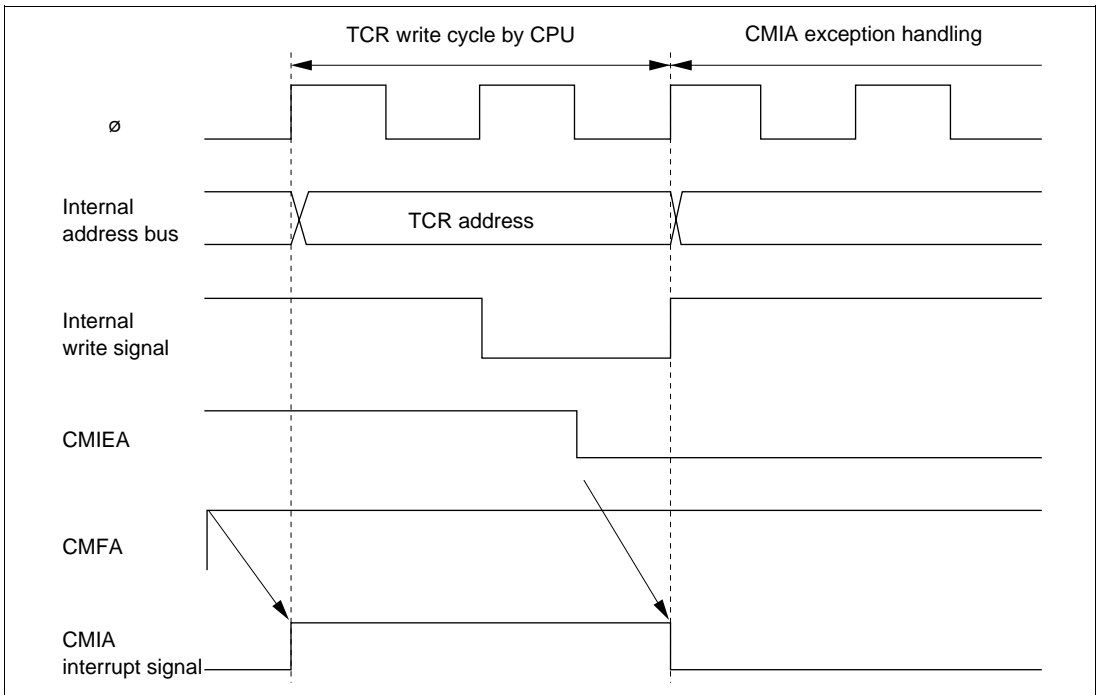
### 5.5.1 Contention between Interrupt Generation and Disabling

When an interrupt enable bit is cleared to 0 to disable interrupts, the disabling becomes effective after execution of the instruction.

In other words, when an interrupt enable bit is cleared to 0 by an instruction such as BCLR or MOV, if an interrupt is generated during execution of the instruction, the interrupt concerned will still be enabled on completion of the instruction, and so interrupt exception handling for that interrupt will be executed on completion of the instruction. However, if there is an interrupt request of higher priority than that interrupt, interrupt exception handling will be executed for the higher-priority interrupt, and the lower-priority interrupt will be ignored.

The same also applies when an interrupt source flag is cleared to 0.

Figure 5.8 shows an example in which the CMIEA bit in 8-bit timer TCR is cleared to 0.



**Figure 5.8 Contention between Interrupt Generation and Disabling**

The above contention will not occur if an enable bit or interrupt source flag is cleared to 0 while the interrupt is masked.

## 5.5.2 Instructions that Disable Interrupts

Instructions that disable interrupts are LDC, ANDC, ORC, and XORC. After any of these instructions is executed, all interrupts including NMI are disabled and the next instruction is always executed. When the I bit is set by one of these instructions, the new value becomes valid two states after execution of the instruction ends.

## 5.5.3 Times when Interrupts are Disabled

There are times when interrupt acceptance is disabled by the interrupt controller.

The interrupt controller disables interrupt acceptance for a 3-state period after the CPU has updated the mask level with an LDC, ANDC, ORC, or XORC instruction.

## 5.5.4 Interrupts during Execution of EEPMOV Instruction

Interrupt operation differs between the EEPMOV.B instruction and the EEPMOV.W instruction.

With the EEPMOV.B instruction, an interrupt request (including NMI) issued during the transfer is not accepted until the move is completed.

With the EEPMOV.W instruction, if an interrupt request is issued during the transfer, interrupt exception handling starts at a break in the transfer cycle. The PC value saved on the stack in this case is the address of the next instruction.

Therefore, if an interrupt is generated during execution of an EEPMOV.W instruction, the following coding should be used.

```
L1:  EEPMOV.W
      MOV.W   R4,R4
      BNE    L1
```

## 5.6 DTC Activation by Interrupt

### 5.6.1 Overview

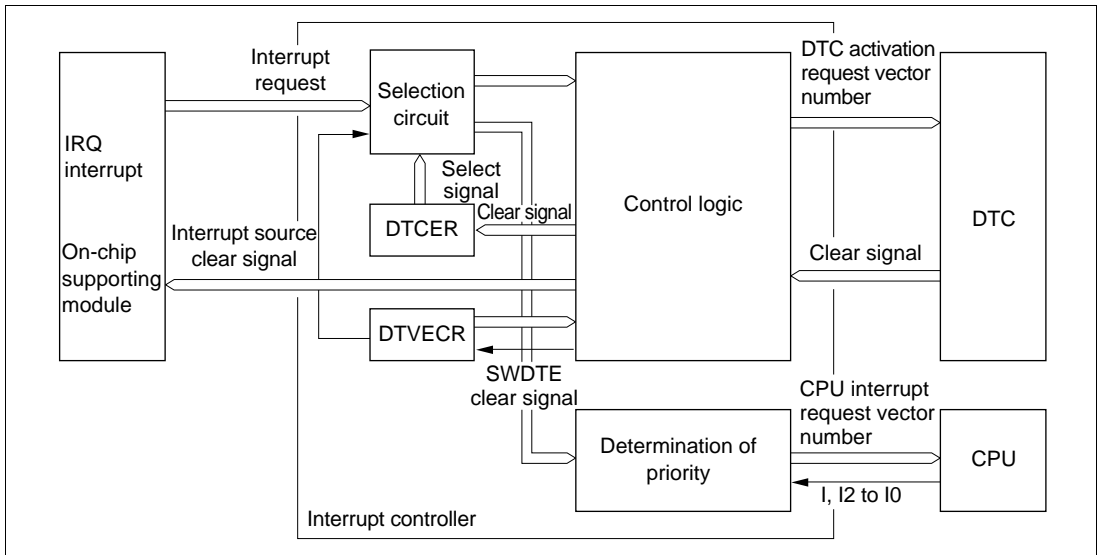
The DTC can be activated by an interrupt. In this case, the following options are available:

- Interrupt request to CPU
- Activation request to DTC
- Selection of a number of the above

For details of interrupt requests that can be used with to activate the DTC, see section 8, Data Transfer Controller.

### 5.6.2 Block Diagram

Figure 5.9 shows a block diagram of the DTC interrupt controller.



**Figure 5.9** Interrupt Control for DTC



### 5.6.3 Operation

The interrupt controller has three main functions in DTC control.

**(1) Selection of Interrupt Source:** Interrupt sources can be specified as DTC activation requests or CPU interrupt requests by means of the DTCE bit of DTCERA to DTCERF, and DTCERI in the DTC.

After a DTC data transfer, the DTCE bit can be cleared to 0 and an interrupt request sent to the CPU in accordance with the specification of the DISEL bit of MRB in the DTC.

When the DTC has performed the specified number of data transfers and the transfer counter value is zero, the DTCE bit is cleared to 0 and an interrupt request is sent to the CPU after the DTC data transfer.

**(2) Determination of Priority:** The DTC activation source is selected in accordance with the default priority order, and is not affected by mask or priority levels. See section 8.3.3, DTC Vector Table, for the respective priorities.

**(3) Operation Order:** If the same interrupt is selected as a DTC activation source and a CPU interrupt source, the DTC data transfer is performed first, followed by CPU interrupt exception handling.

Table 5.11 summarizes interrupt source selection and interrupt source clearance control according to the settings of the DTCE bit of DTCERA to DTCERF and DTCERI in the DTC, and the DISEL bit of MRB in the DTC.

**Table 5.11 Interrupt Source Selection and Clearing Control**

Settings		Interrupt Source Selection/Clearing Control	
DTC		DTC	CPU
DTCE	DISEL		
0	*	X	Δ
1	0	Δ	X
	1	○	Δ

#### Legend

- Δ : The relevant interrupt is used. Interrupt source clearing is performed.  
(The CPU should clear the source flag in the interrupt handling routine.)
- : The relevant interrupt is used. The interrupt source is not cleared.
- X : The relevant bit cannot be used.
- \* : Don't care

**(4) Usage Note:** SCI and A/D converter interrupt sources are cleared when the DTC reads or writes to the prescribed register, and are not dependent on the DTCE and DISEL bits.

# Section 6 PC Break Controller (PBC)

## 6.1 Overview

The PC break controller (PBC) provides functions that simplify program debugging. Using these functions, it is easy to create a self-monitoring debugger, enabling programs to be debugged with the chip alone, without using an in-circuit emulator. Four break conditions can be set in the PBC: instruction fetch, data read, data write, and data read/write.

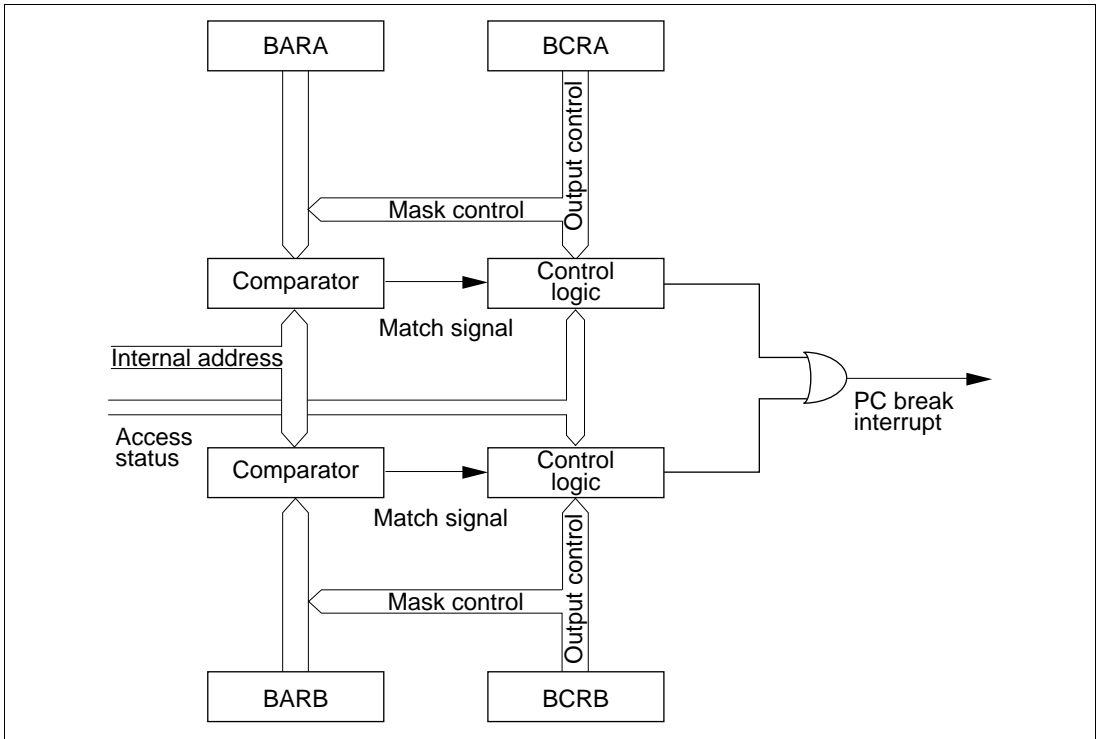
### 6.1.1 Features

The PC break controller has the following features:

- Two break channels (A and B)
- The following can be set as break compare conditions:
  - 24 address bits
    - Bit masking possible
  - Bus cycle
    - Instruction fetch
    - Data access: data read, data write, data read/write
  - Bus master
    - Either CPU or CPU/DTC can be selected
- The timing of PC break exception handling after the occurrence of a break condition is as follows:
  - Immediately before execution of the instruction fetched at the set address (instruction fetch)
  - Immediately after execution of the instruction that accesses data at the set address (data access)
- Module stop mode can be set
  - The initial setting is for PBC operation to be halted. Register access is enabled by clearing module stop mode.

## 6.1.2 Block Diagram

Figure 6.1 shows a block diagram of the PC break controller.



**Figure 6.1 Block Diagram of PC Break Controller**

### 6.1.3 Register Configuration

Table 6.1 shows the PC break controller registers.

**Table 6.1 PC Break Controller Registers**

Name	Abbreviation	R/W	Initial Value	Address* <sup>1</sup>
Break address register A	BARA	R/W	H'000000	H'FE00
Break address register B	BARB	R/W	H'000000	H'FE04
Break control register A	BCRA	R(W)* <sup>2</sup>	H'00	H'FE08
Break control register B	BCRB	R(W)* <sup>2</sup>	H'00	H'FE09
Module stop control register C	MSTPCRC	R/W	H'FF	H'FDEA

Notes: \*1 Lower 16 bits of the address.

\*2 Only 0 can be written, to clear the flag.

## 6.2 Register Descriptions

### 6.2.1 Break Address Register A (BARA)

Bit	31	...	24	23	22	21	20	19	18	17	16	...	7	6	5	4	3	2	1	0
	—	...	—	BAA 23	BAA 22	BAA 21	BAA 20	BAA 19	BAA 18	BAA 17	BAA 16	...	BAA 7	BAA 6	BAA 5	BAA 4	BAA 3	BAA 2	BAA 1	BAA 0
Initial value	Unde- fined	...	Unde- fined	0	0	0	0	0	0	0	0	...	0	0	0	0	0	0	0	0
Read/Write	—	...	—	R/W	R/W	R/W	R/W	R/W	R/W	R/W	R/W	...	R/W	R/W	R/W	R/W	R/W	R/W	R/W	R/W

BARA is a 32-bit readable/writable register that specifies the channel A break address.

BAA23 to BAA0 are initialized to H'000000 by a power-on reset and in hardware standby mode.

**Bits 31 to 24—Reserved:** These bits return an undefined value if read, and cannot be modified.

**Bits 23 to 0—Break Address A23 to A0 (BAA23 to BAA0):** These bits hold the channel A PC break address.

## 6.2.2 Break Address Register B (BARB)

BARB is the channel B break address register. The bit configuration is the same as for BARA.

## 6.2.3 Break Control Register A (BCRA)

Bit	:	7	6	5	4	3	2	1	0
		CMFA	CDA	BAMRA2	BAMRA1	BAMRA0	CSELA1	CSELA0	BIEA
Initial value	:	0	0	0	0	0	0	0	0
R/W	:	R(W)*	R/W	R/W	R/W	R/W	R/W	R/W	R/W

Note: \* Only 0 can be written to bit 7, to clear this flag.

BCRA is an 8-bit readable/writable register that controls channel A PC breaks. BCRA (1) selects the break condition bus master, (2) specifies bits subject to address comparison masking, and (3) specifies whether the break condition is applied to an instruction fetch or a data access. It also contains a condition match flag.

BCRA is initialized to H'00 by a power-on reset and in hardware standby mode.

**Bit 7—Condition Match Flag A (CMFA):** Set to 1 when a break condition set for channel A is satisfied. This flag is not cleared to 0.

### Bit 7

CMFA	Description
0	[Clearing condition] When 0 is written to CMFA after reading* CMFA = 1 (Initial value)
1	[Setting condition] When a condition set for channel A is satisfied

Note: \* Read the state wherein CMFA = 1 twice or more, when the CMFA is polled after inhibiting the PC break interrupt.

**Bit 6—CPU Cycle/DTC Cycle Select A (CDA):** Selects the channel A break condition bus master.

### Bit 6

CDA	Description
0	PC break is performed when CPU is bus master (Initial value)
1	PC break is performed when CPU or DTC is bus master

**Bits 5 to 3—Break Address Mask Register A2 to A0 (BAMRA2 to BAMRA0):** These bits specify which bits of the break address (BAA23 to BAA0) set in BARA are to be masked.

Bit 5	Bit 4	Bit 3	Description
BAMRA2	BAMRA1	BAMRA0	
0	0	0	All BARA bits are unmasked and included in break conditions (Initial value)
		1	BAA0 (lowest bit) is masked, and not included in break conditions
	1	0	BAA1 to 0 (lower 2 bits) are masked, and not included in break conditions
1	0	1	BAA2 to 0 (lower 3 bits) are masked, and not included in break conditions
		0	BAA3 to 0 (lower 4 bits) are masked, and not included in break conditions
	1	BAA7 to 0 (lower 8 bits) are masked, and not included in break conditions	
	1	0	BAA11 to 0 (lower 12 bits) are masked, and not included in break conditions
	1	BAA15 to 0 (lower 16 bits) are masked, and not included in break conditions	

**Bits 2 and 1—Break Condition Select A (CSELA1, CSELA0):** These bits selection an instruction fetch, data read, data write, or data read/write cycle as the channel A break condition.

Bit 2	Bit 1	Description
CSELA1	CSELA0	
0	0	Instruction fetch is used as break condition (Initial value)
	1	Data read cycle is used as break condition
1	0	Data write cycle is used as break condition
	1	Data read/write cycle is used as break condition

**Bit 0—Break Interrupt Enable A (BIEA):** Enables or disables channel A PC break interrupts.

Bit 0	Description
BIEA	
0	PC break interrupts are disabled (Initial value)
1	PC break interrupts are enabled

## 6.2.4 Break Control Register B (BCRB)

BCRB is the channel B break control register. The bit configuration is the same as for BCRA.

## 6.2.5 Module Stop Control Register C (MSTPCRC)

Bit	:	7	6	5	4	3	2	1	0
		MSTPC7	MSTPC6	MSTPC5	MSTPC4	MSTPC3	MSTPC2	MSTPC1	MSTPC0
Initial value	:	1	1	1	1	1	1	1	1
R/W	:	R/W	R/W	R/W	R/W	R/W	R/W	R/W	R/W

MSTPCRC is an 8-bit readable/writable register that performs module stop mode control.

When the MSTPC4 bit is set to 1, PC break controller operation is stopped at the end of the bus cycle, and module stop mode is entered. Register read/write accesses are not possible in module stop mode. For details, see section 19.5, Module Stop Mode.

MSTPCRC is initialized to H'FF by a reset and in hardware standby mode. It is not initialized in software standby mode.

**Bit 4—Module Stop (MSTPC4):** Specifies the PC break controller module stop mode.

### Bit 4

MSTPC4	Description
0	PC break controller module stop mode is cleared
1	PC break controller module stop mode is set (Initial value)



## 6.3 Operation

The operation flow from break condition setting to PC break interrupt exception handling is shown in sections 6.3.1 and 6.3.2, taking the example of channel A.

### 6.3.1 PC Break Interrupt Due to Instruction Fetch

#### (1) Initial settings

- Set the break address in BARA. For a PC break caused by an instruction fetch, set the address of the first instruction byte as the break address.
- Set the break conditions in BCRA.

**BCRA bit 6 (CDA):** With a PC break caused by an instruction fetch, the bus master must be the CPU. Set 0 to select the CPU.

**BCRA bits 5 to 3 (BAMA2 to 0):** Set the address bits to be masked.

**BCRA bits 2 to 1 (CSELA1 to 0):** Set 00 to specify an instruction fetch as the break condition.

**BCRA bit 0 (BIEA):** Set to 1 to enable break interrupts.

#### (2) Satisfaction of break condition

- When the instruction at the set address is fetched, a PC break request is generated immediately before execution of the fetched instruction, and the condition match flag (CMFA) is set.

#### (3) Interrupt handling

- After priority determination by the interrupt controller, PC break interrupt exception handling is started.

### 6.3.2 PC Break Interrupt Due to Data Access

#### (1) Initial settings

- Set the break address in BARA. For a PC break caused by a data access, set the target ROM, RAM, I/O, or external address space address as the break address. Stack operations and branch address reads are included in data accesses.
- Set the break conditions in BCRA.

**BCRA bit 6 (CDA):** Select the bus master.

**BCRA bits 5 to 3 (BAMA2 to 0):** Set the address bits to be masked.

**BCRA bits 2 to 1 (CSELA1 to 0):** Set 01, 10, or 11 to specify data access as the break condition.

**BCRA bit 0 (BIEA):** Set to 1 to enable break interrupts.

## (2) Satisfaction of break condition

- After execution of the instruction that performs a data access on the set address, a PC break request is generated and the condition match flag (CMFA) is set.

## (3) Interrupt handling

- After priority determination by the interrupt controller, PC break interrupt exception handling is started.

### 6.3.3 Notes on PC Break Interrupt Handling

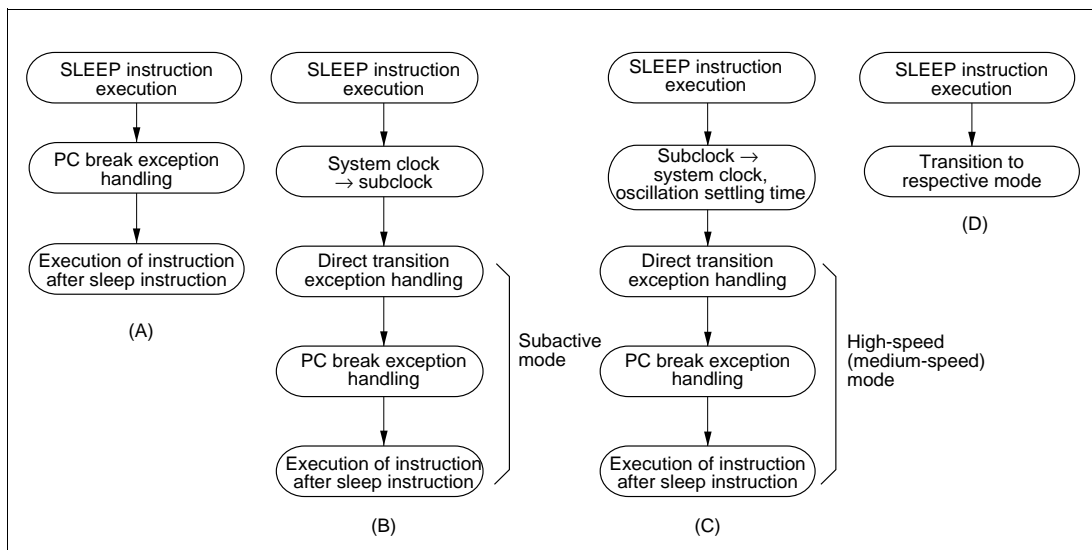
- (1) The PC break interrupt is shared by channels A and B. The channel from which the request was issued must be determined by the interrupt handler.
- (2) The CMFA and CMFB flags are not cleared to 0, so 0 must be written to CMFA or CMFB after first reading the flag while it is set to 1. If the flag is left set to 1, another interrupt will be requested after interrupt handling ends.
- (3) A PC break interrupt generated when the DTC is the bus master is accepted after the bus has been transferred to the CPU by the bus controller.

### 6.3.4 Operation in Transitions to Power-Down Modes

The operation when a PC break interrupt is set for an instruction fetch at the address after a SLEEP instruction is shown below.

- (1) When the SLEEP instruction causes a transition from high-speed (medium-speed) mode to sleep mode, or from subactive mode to subsleep mode:  
After execution of the SLEEP instruction, a transition is not made to sleep mode or subsleep mode, and PC break interrupt handling is executed. After execution of PC break interrupt handling, the instruction at the address after the SLEEP instruction is executed (figure 6.2 (A)).
- (2) When the SLEEP instruction causes a transition from high-speed (medium-speed) mode to subactive mode:  
After execution of the SLEEP instruction, a transition is made to subactive mode via direct transition exception handling. After the transition, PC break interrupt handling is executed, then the instruction at the address after the SLEEP instruction is executed (figure 6.2 (B)).
- (3) When the SLEEP instruction causes a transition from subactive mode to high-speed (medium-speed) mode:  
After execution of the SLEEP instruction, and following the clock oscillation settling time, a transition is made to high-speed (medium-speed) mode via direct transition exception handling. After the transition, PC break interrupt handling is executed, then the instruction at the address after the SLEEP instruction is executed (figure 6.2 (C)).

- (4) When the SLEEP instruction causes a transition to software standby mode or watch mode:  
 After execution of the SLEEP instruction, a transition is made to the respective mode, and PC break interrupt handling is not executed. However, the CMFA or CMFB flag is set (figure 6.2 (D)).



**Figure 6.2 Operation in Power-Down Mode Transitions**

### 6.3.5 PC Break Operation in Continuous Data Transfer

If a PC break interrupt is generated when the following operations are being performed, exception handling is executed on completion of the specified transfer.

- (1) When a PC break interrupt is generated at the transfer address of an EEPMOV.B instruction:  
 PC break exception handling is executed after all data transfers have been completed and the EEPMOV.B instruction has ended.
- (2) When a PC break interrupt is generated at a DTC transfer address:  
 PC break exception handling is executed after the DTC has completed the specified number of data transfers, or after data for which the DISEL bit is set to 1 has been transferred.

### 6.3.6 When Instruction Execution is Delayed by One State

Caution is required in the following cases, as instruction execution is one state later than usual.

- (1) When the PBC is enabled (i.e. when the break interrupt enable bit is set to 1), execution of a one-word branch instruction (Bcc d:8, BSR, JSR, JMP, TRAPA, RTE, or RTS) located in on-chip ROM or RAM is always delayed by one state.
- (2) When break interruption by instruction fetch is set, the set address indicates on-chip ROM or RAM space, and that address is used for data access, the instruction that executes the data access is one state later than in normal operation.
- (3) When break interruption by instruction fetch is set and a break interrupt is generated, if the executing instruction immediately preceding the set instruction has one of the addressing modes shown below, and that address indicates on-chip ROM or RAM, the instruction will be one state later than in normal operation.  
@ERn, @(d:16,ERn), @(d:32,ERn), @-ERn/ERn+, @aa:8, @aa:24, @aa:32, @(d:8,PC), @(d:16,PC), @@aa:8
- (4) When break interruption by instruction fetch is set and a break interrupt is generated, if the executing instruction immediately preceding the set instruction is NOP or SLEEP, or has #xx,Rn as its addressing mode, and that instruction is located in on-chip ROM or RAM, the instruction will be one state later than in normal operation.

### 6.3.7 Additional Notes

- (1) When a PC break is set for an instruction fetch at the address following a BSR, JSR, JMP, TRAPA, RTE, or RTS instruction:  
Even if the instruction at the address following a BSR, JSR, JMP, TRAPA, RTE, or RTS instruction is fetched, it is not executed, and so a PC break interrupt is not generated by the instruction fetch at the next address.
- (2) When the I bit is set by an LDC, ANDC, ORC, or XORC instruction, a PC break interrupt becomes valid two states after the end of the executing instruction. If a PC break interrupt is set for the instruction following one of these instructions, since interrupts, including NMI, are disabled for a 3-state period in the case of LDC, ANDC, ORC, and XORC, the next instruction is always executed. For details, see section 5, Interrupt Controller.
- (3) When a PC break is set for an instruction fetch at the address following a Bcc instruction:  
A PC break interrupt is generated if the instruction at the next address is executed in accordance with the branch condition, but is not generated if the instruction at the next address is not executed.
- (4) When a PC break is set for an instruction fetch at the branch destination address of a Bcc instruction:  
A PC break interrupt is generated if the instruction at the branch destination is executed in accordance with the branch condition, but is not generated if the instruction at the branch destination is not executed.



# Section 7 Bus Controller

## 7.1 Overview

The LSI has a built-in bus controller (BSC) that manages the external address space divided into eight areas. The bus specifications, such as bus width and number of access states, can be set independently for each area, enabling multiple memories to be connected easily.

The bus controller also has a bus arbitration function, and controls the operation of the internal bus masters: the CPU and data transfer controller (DTC).

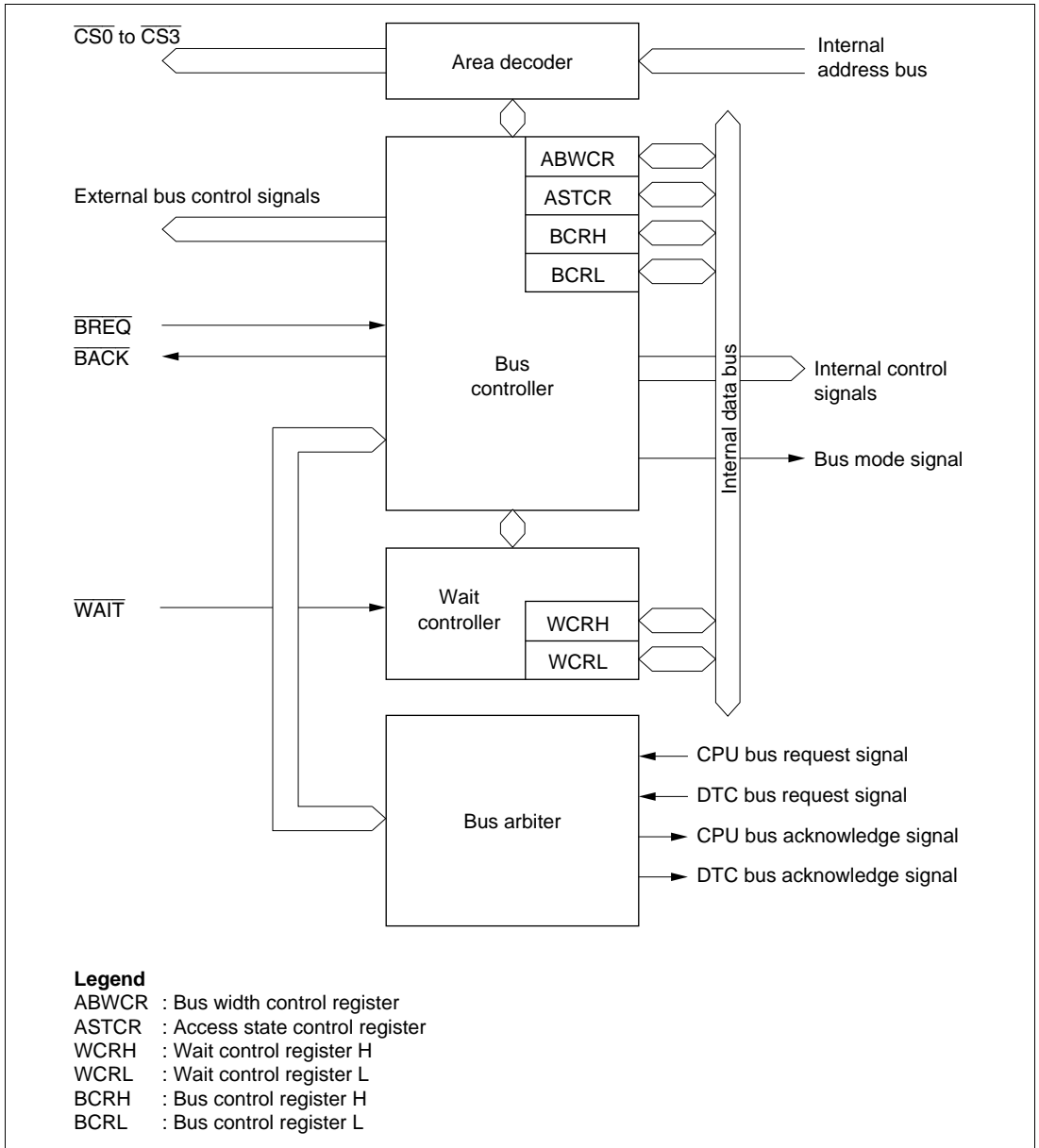
### 7.1.1 Features

The features of the bus controller are listed below.

- Manages external address space in area units
  - Manages the external space as 8 areas of 2-Mbytes
  - Bus specifications can be set independently for each area
  - Burst ROM interface can be set
- Basic bus interface
  - Chip select ( $\overline{CS0}$  to  $\overline{CS3}$ ) can be output for areas 0 to 3
  - 8-bit access or 16-bit access can be selected for each area
  - 2-state access or 3-state access can be selected for each area
  - Program wait states can be inserted for each area
- Burst ROM interface
  - Burst ROM interface can be set for area 0
  - Choice of 1- or 2-state burst access
- Idle cycle insertion
  - An idle cycle can be inserted in case of an external read cycle between different areas
  - An idle cycle can be inserted in case of an external write cycle immediately after an external read cycle
- Bus arbitration function
  - Includes a bus arbiter that arbitrates bus mastership among the CPU and DTC
- Other features
  - External bus release function

## 7.1.2 Block Diagram

Figure 7.1 shows a block diagram of the bus controller.



**Figure 7.1 Block Diagram of Bus Controller**



### 7.1.3 Pin Configuration

Table 7.1 summarizes the pins of the bus controller.

**Table 7.1 Bus Controller Pins**

<b>Name</b>	<b>Symbol</b>	<b>I/O</b>	<b>Function</b>
Address strobe	$\overline{AS}$	Output	Strobe signal indicating that address output on address bus is enabled.
Read	$\overline{RD}$	Output	Strobe signal indicating that external space is being read.
High write	$\overline{HWR}$	Output	Strobe signal indicating that external space is to be written, and upper half (D15 to D8) of data bus is enabled.
Low write	$\overline{LWR}$	Output	Strobe signal indicating that external space is to be written, and lower half (D7 to D0) of data bus is enabled.
Chip select 0 to 3	$\overline{CS0}$ to $\overline{CS3}$	Output	Strobe signal indicating that areas 0 to 3 are selected.
Wait	$\overline{WAIT}$	Input	Wait request signal when accessing external 3-state access space.
Bus request	$\overline{BREQ}$	Input	Request signal that releases bus to external device.
Bus request acknowledge	$\overline{BACK}$	Output	Acknowledge signal indicating that bus has been released.

## 7.1.4 Register Configuration

Table 7.2 summarizes the registers of the bus controller.

**Table 7.2 Bus Controller Registers**

Name	Abbreviation	R/W	Initial value	Address* <sup>1</sup>
Bus width control register	ABWCR	R/W	H'FF/H'00* <sup>2</sup>	H'FED0
Access state control register	ASTCR	R/W	H'FF	H'FED1
Wait control register H	WCRH	R/W	H'FF	H'FED2
Wait control register L	WCRL	R/W	H'FF	H'FED3
Bus control register H	BCRH	R/W	H'D0	H'FED4
Bus control register L	BCRL	R/W	H'08	H'FED5
Pin function control register	PFCR	R/W	H'0D/H'00* <sup>3</sup>	H'FDEB

Notes: \*1 Lower 16 bits of the address.

\*2 Determined by the MCU operating mode. Initialized to H'00 in mode 4, and to H'FF in modes 5 to 7.

\*3 Initialized to H'0D in modes 4 and 5, and to H'00 in modes 6 and 7.

## 7.2 Register Descriptions

### 7.2.1 Bus Width Control Register (ABWCR)

Bit	:	7	6	5	4	3	2	1	0
		ABW7	ABW6	ABW5	ABW4	ABW3	ABW2	ABW1	ABW0
Modes 5 to 7									
Initial value	:	1	1	1	1	1	1	1	1
R/W	:	R/W	R/W	R/W	R/W	R/W	R/W	R/W	R/W
Mode 4									
Initial value	:	0	0	0	0	0	0	0	0
R/W	:	R/W	R/W	R/W	R/W	R/W	R/W	R/W	R/W

ABWCR is an 8-bit readable/writable register that designates each area for either 8-bit access or 16-bit access.

ABWCR sets the data bus width for the external memory space. The bus width for on-chip memory and internal I/O registers is fixed regardless of the settings in ABWCR.

After a power-on reset and in hardware standby mode, ABWCR is initialized to H'FF in modes 5, 6, 7, and to H'00 in mode 4. It is not initialized in software standby mode.

**Bits 7 to 0—Area 7 to 0 Bus Width Control (ABW7 to ABW0):** These bits select whether the corresponding area is to be designated for 8-bit access or 16-bit access.

**Bit n**

<b>ABWn</b>	<b>Description</b>
0	Area n is designated for 16-bit access
1	Area n is designated for 8-bit access

(n = 7 to 0)

## 7.2.2 Access State Control Register (ASTCR)

Bit	:	7	6	5	4	3	2	1	0
		AST7	AST6	AST5	AST4	AST3	AST2	AST1	AST0
Initial value :		1	1	1	1	1	1	1	1
R/W	:	R/W	R/W	R/W	R/W	R/W	R/W	R/W	R/W

ASTCR is an 8-bit readable/writable register that designates each area as either a 2-state access space or a 3-state access space.

ASTCR sets the number of access states for the external memory space. The number of access states for on-chip memory and internal I/O registers is fixed regardless of the settings in ASTCR.

ASTCR is initialized to H'FF by a power-on reset and in hardware standby mode. It is not initialized in software standby mode.

**Bits 7 to 0—Area 7 to 0 Access State Control (AST7 to AST0):** These bits select whether the corresponding area is to be designated as a 2-state access space or a 3-state access space.

Wait state insertion is enabled or disabled at the same time.

**Bit n**

<b>ASTn</b>	<b>Description</b>
0	Area n is designated for 2-state access Wait state insertion in area n external space is disabled
1	Area n is designated for 3-state access Wait state insertion in area n external space is enabled

(Initial value)

(n = 7 to 0)

### 7.2.3 Wait Control Registers H and L (WCRH, WCRL)

WCRH and WCRL are 8-bit readable/writable registers that select the number of program wait states for each area.

Program waits are not inserted in the case of on-chip memory or internal I/O registers.

WCRH and WCRL are initialized to H'FF by a power-on reset and in hardware standby mode. They are not initialized in software standby mode.

#### WCRH

Bit	:	7	6	5	4	3	2	1	0
		W71	W70	W61	W60	W51	W50	W41	W40
Initial value	:	1	1	1	1	1	1	1	1
R/W	:	R/W	R/W	R/W	R/W	R/W	R/W	R/W	R/W

**Bits 7 and 6—Area 7 Wait Control 1 and 0 (W71, W70):** These bits select the number of program wait states when area 7 in external space is accessed while the AST7 bit in ASTCR is set to 1.

Bit 7	Bit 6	Description
W71	W70	
0	0	Program wait not inserted when external space area 7 is accessed
	1	1 program wait state inserted when external space area 7 is accessed
1	0	2 program wait states inserted when external space area 7 is accessed
	1	3 program wait states inserted when external space area 7 is accessed (Initial value)

**Bits 5 and 4—Area 6 Wait Control 1 and 0 (W61, W60):** These bits select the number of program wait states when area 6 in external space is accessed while the AST6 bit in ASTCR is set to 1.

Bit 5	Bit 4	Description
W61	W60	
0	0	Program wait not inserted when external space area 6 is accessed
	1	1 program wait state inserted when external space area 6 is accessed
1	0	2 program wait states inserted when external space area 6 is accessed
	1	3 program wait states inserted when external space area 6 is accessed (Initial value)

**Bits 3 and 2—Area 5 Wait Control 1 and 0 (W51, W50):** These bits select the number of program wait states when area 5 in external space is accessed while the AST5 bit in ASTCR is set to 1.

Bit 3	Bit 2	Description
W51	W50	
0	0	Program wait not inserted when external space area 5 is accessed
	1	1 program wait state inserted when external space area 5 is accessed
1	0	2 program wait states inserted when external space area 5 is accessed
	1	3 program wait states inserted when external space area 5 is accessed (Initial value)

**Bits 1 and 0—Area 4 Wait Control 1 and 0 (W41, W40):** These bits select the number of program wait states when area 4 in external space is accessed while the AST4 bit in ASTCR is set to 1.

Bit 1	Bit 0	Description
W41	W40	
0	0	Program wait not inserted when external space area 4 is accessed
	1	1 program wait state inserted when external space area 4 is accessed
1	0	2 program wait states inserted when external space area 4 is accessed
	1	3 program wait states inserted when external space area 4 is accessed (Initial value)

## WCRL

Bit	:	7	6	5	4	3	2	1	0
		W31	W30	W21	W20	W11	W10	W01	W00
Initial value	:	1	1	1	1	1	1	1	1
R/W	:	R/W	R/W	R/W	R/W	R/W	R/W	R/W	R/W

**Bits 7 and 6—Area 3 Wait Control 1 and 0 (W31, W30):** These bits select the number of program wait states when area 3 in external space is accessed while the AST3 bit in ASTCR is set to 1.

Bit 7	Bit 6	
W31	W30	Description
0	0	Program wait not inserted when external space area 3 is accessed
	1	1 program wait state inserted when external space area 3 is accessed
1	0	2 program wait states inserted when external space area 3 is accessed
	1	3 program wait states inserted when external space area 3 is accessed (Initial value)

**Bits 5 and 4—Area 2 Wait Control 1 and 0 (W21, W20):** These bits select the number of program wait states when area 2 in external space is accessed while the AST2 bit in ASTCR is set to 1.

Bit 5	Bit 4	
W21	W20	Description
0	0	Program wait not inserted when external space area 2 is accessed
	1	1 program wait state inserted when external space area 2 is accessed
1	0	2 program wait states inserted when external space area 2 is accessed
	1	3 program wait states inserted when external space area 2 is accessed (Initial value)

**Bits 3 and 2—Area 1 Wait Control 1 and 0 (W11, W10):** These bits select the number of program wait states when area 1 in external space is accessed while the AST1 bit in ASTCR is set to 1.

Bit 3	Bit 2	
W11	W10	Description
0	0	Program wait not inserted when external space area 1 is accessed
	1	1 program wait state inserted when external space area 1 is accessed
1	0	2 program wait states inserted when external space area 1 is accessed
	1	3 program wait states inserted when external space area 1 is accessed (Initial value)

**Bits 1 and 0—Area 0 Wait Control 1 and 0 (W01, W00):** These bits select the number of program wait states when area 0 in external space is accessed while the AST0 bit in ASTCR is set to 1.

Bit 1	Bit 0	Description
W01	0	Program wait not inserted when external space area 0 is accessed
	1	1 program wait state inserted when external space area 0 is accessed
1	0	2 program wait states inserted when external space area 0 is accessed
	1	3 program wait states inserted when external space area 0 is accessed (Initial value)

#### 7.2.4 Bus Control Register H (BCRH)

Bit	:	7	6	5	4	3	2	1	0
		ICIS1	ICIS0	BRSTRM	BRSTS1	BRSTS0	—	—	—
Initial value	:	1	1	0	1	0	0	0	0
R/W	:	R/W	R/W	R/W	R/W	R/W	R/W	R/W	R/W

BCRH is an 8-bit readable/writable register that selects enabling or disabling of idle cycle insertion, and the memory interface for area 0.

BCRH is initialized to H'D0 by a power-on reset and in hardware standby mode. It is not initialized in software standby mode.

**Bit 7—Idle Cycle Insert 1 (ICIS1):** Selects whether or not one idle cycle state is to be inserted between bus cycles when successive external read cycles are performed in different areas.

Bit 7	Description
ICIS1	
0	Idle cycle not inserted in case of successive external read cycles in different areas
1	Idle cycle inserted in case of successive external read cycles in different areas (Initial value)

**Bit 6—Idle Cycle Insert 0 (ICIS0):** Selects whether or not one idle cycle state is to be inserted between bus cycles when successive external read and external write cycles are performed .

**Bit 6**

ICIS0	Description
0	Idle cycle not inserted in case of successive external read and external write cycles
1	Idle cycle inserted in case of successive external read and external write cycles (Initial value)

**Bit 5—Burst ROM Enable (BRSTRM):** Selects whether area 0 is used as a burst ROM interface.

**Bit 5**

BRSTRM	Description
0	Area 0 is basic bus interface (Initial value)
1	Area 0 is burst ROM interface

**Bit 4—Burst Cycle Select 1 (BRSTS1):** Selects the number of burst cycles for the burst ROM interface.

**Bit 4**

BRSTS1	Description
0	Burst cycle comprises 1 state
1	Burst cycle comprises 2 states (Initial value)

**Bit 3—Burst Cycle Select 0 (BRSTS0):** Selects the number of words that can be accessed in a burst ROM interface burst access.

**Bit 3**

BRSTS0	Description
0	Max. 4 words in burst access (Initial value)
1	Max. 8 words in burst access

**Bits 2 to 0—Reserved:** Only 0 should be written to these bits.



## 7.2.5 Bus Control Register L (BCRL)

Bit	:	7	6	5	4	3	2	1	0
		BRLE	—	—	—	—	—	—	WAITE
Initial value :		0	0	0	0	1	0	0	0
R/W	:	R/W	R/W	—	R/W	R/W	R/W	R/W	R/W

BCRL is an 8-bit readable/writable register that performs selection of the external bus-released state protocol, and enabling or disabling of  $\overline{\text{WAIT}}$  pin input.

BCRL is initialized to H'08 by a power-on reset and in hardware standby mode. It is not initialized in software standby mode.

**Bit 7—Bus Release Enable (BRLE):** Enables or disables external bus release.

### Bit 7

BRLE	Description
0	External bus release is disabled. $\overline{\text{BREQ}}$ and $\overline{\text{BACK}}$ can be used as I/O ports. (Initial value)
1	External bus release is enabled.

**Bit 6—Reserved:** Only 0 should be written to this bit.

**Bit 5—Reserved:** This bit cannot be modified and is always read as 0.

**Bit 4—Reserved:** Only 0 should be written to this bit.

**Bit 3—Reserved:** Only 1 should be written to this bit.

**Bits 2 and 1—Reserved:** Only 0 should be written to these bits.

**Bit 0—WAIT Pin Enable (WAITE):** Selects enabling or disabling of wait input by the  $\overline{\text{WAIT}}$  pin.

### Bit 0

WAITE	Description
0	Wait input by $\overline{\text{WAIT}}$ pin disabled. $\overline{\text{WAIT}}$ pin can be used as I/O port. (Initial value)
1	Wait input by $\overline{\text{WAIT}}$ pin enabled

## 7.2.6 Pin Function Control Register (PFCR)

Bit	:	7	6	5	4	3	2	1	0
		—	—	BUZZE	—	AE3	AE2	AE1	AE0
Modes 4 and 5									
Initial value	:	0	0	0	0	1	1	0	1
Modes 6 and 7									
Initial value	:	0	0	0	0	0	0	0	0
R/W	:	R/W	R/W	R/W	R/W	R/W	R/W	R/W	R/W

PFCR is an 8-bit readable/writable register that performs address output control in external expanded mode.

PFCR is initialized to H'0D (modes 4 and 5) or H'00 (modes 6 and 7) by a power-on reset and in hardware standby mode. It retains its previous state in software standby mode.

**Bits 7 and 6—Reserved:** Only 0 should be written to these bits.

**Bit 5—BUZZ Output Enable (BUZZE):** Enables or disables BUZZ output from the PF1 pin. The WDT1 input clock selected with bits PSS and CKS2 to CKS0 is output as the BUZZ signal.

### Bit 5

BUZZE	Description
0	Functions as PF1 I/O pin (Initial value)
1	Functions as BUZZ output pin

**Bit 4—Reserved:** Only 0 should be written to this bit.

**Bits 3 to 0—Address Output Enable 3 to 0 (AE3 to AE0):** These bits select enabling or disabling of address outputs A8 to A23 in ROMless expanded mode and modes with ROM. When a pin is enabled for address output, the address is output regardless of the corresponding DDR setting. When a pin is disabled for address output, it becomes an output port when the corresponding DDR bit is set to 1.

Bit 3	Bit 2	Bit 1	Bit 0	Description
AE3	AE2	AE1	AE0	
0	0	0	0	A8 to A23 output disabled (Initial value*1)
			1	A8 output enabled; A9 to A23 output disabled
		1	0	A8, A9 output enabled; A10 to A23 output disabled
			1	A8 to A10 output enabled; A11 to A23 output disabled
	1	0	0	A8 to A11 output enabled; A12 to A23 output disabled
			1	A8 to A12 output enabled; A13 to A23 output disabled
		1	0	A8 to A13 output enabled; A14 to A23 output disabled
			1	A8 to A14 output enabled; A15 to A23 output disabled
1	0	0	0	A8 to A15 output enabled; A16 to A23 output disabled
			1	A8 to A16 output enabled; A17 to A23 output disabled
		1	0	A8 to A17 output enabled; A18 to A23 output disabled
			1	A8 to A18 output enabled; A19 to A23 output disabled
	1	0	0	A8 to A19 output enabled; A20 to A23 output disabled
			1	A8 to A20 output enabled; A21 to A23 output disabled (Initial value*2)
		1	0	A8 to A21 output enabled; A22, A23 output disabled
			1	A8 to A23 output enabled

Notes: \*1 In expanded mode with ROM, bits AE3 to AE0 are initialized to B'0000.

In expanded mode with ROM, address pins A0 to A7 are made address outputs by setting the corresponding DDR bits to 1.

\*2 In ROMless expanded mode, bits AE3 to AE0 are initialized to B'1101.

In ROMless expanded mode, address pins A0 to A7 are always made address output.

## 7.3 Overview of Bus Control

### 7.3.1 Area Partitioning

In advanced mode, the bus controller partitions the 16 Mbytes address space into eight areas, 0 to 7, in 2-Mbyte units, and performs bus control for external space in area units. In normal mode, it controls a 64-kbyte address space comprising part of area 0 (not available in the LSI). Figure 7.2 shows an outline of the memory map.

Chip select signals ( $\overline{CS0}$  to  $\overline{CS3}$ ) can be output for areas 0 to 3.

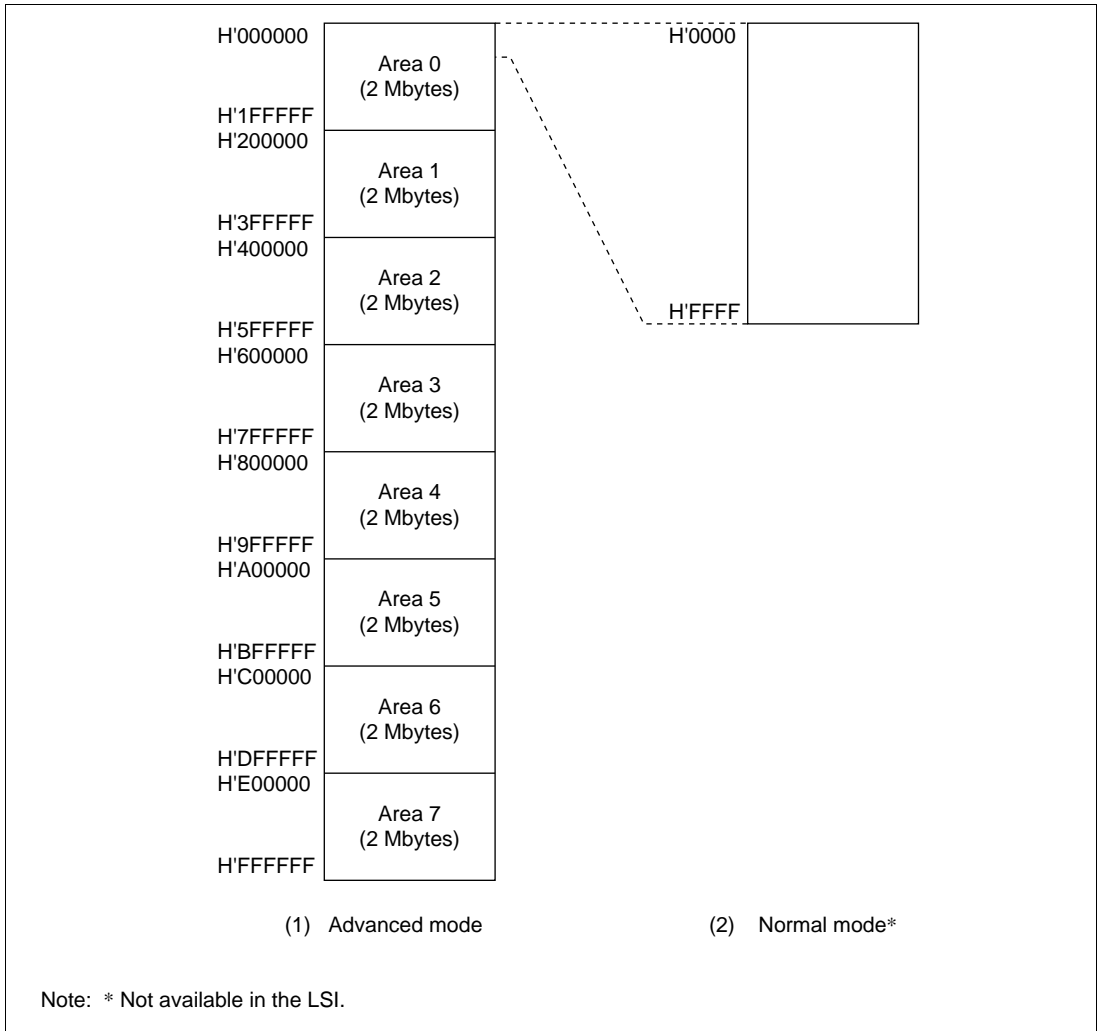


Figure 7.2 Overview of Area Partitioning

### 7.3.2 Bus Specifications

The external space bus specifications consist of three elements: bus width, number of access states, and number of program wait states.

The bus width and number of access states for on-chip memory and internal I/O registers are fixed, and are not affected by the bus controller.

**(1) Bus Width:** A bus width of 8 or 16 bits can be selected with ABWCR. An area for which an 8-bit bus is selected functions as an 8-bit access space, and an area for which a 16-bit bus is selected functions as a 16-bit access space.

If all areas are designated for 8-bit access, 8-bit bus mode is set; if any area is designated for 16-bit access, 16-bit bus mode is set. When the burst ROM interface is designated, 16-bit bus mode is always set.

**(2) Number of Access States:** Two or three access states can be selected with ASTCR. An area for which 2-state access is selected functions as a 2-state access space, and an area for which 3-state access is selected functions as a 3-state access space.

With the burst ROM interface, the number of access states may be determined without regard to ASTCR.

When 2-state access space is designated, wait insertion is disabled.

**(3) Number of Program Wait States:** When 3-state access space is designated by ASTCR, the number of program wait states to be inserted automatically is selected with WCRH and WCRL. From 0 to 3 program wait states can be selected.

Table 7.3 shows the bus specifications for each basic bus interface area.

**Table 7.3 Bus Specifications for Each Area (Basic Bus Interface)**

ABWCR	ASTCR	WCRH, WCRL		Bus Specifications (Basic Bus Interface)		
		Wn1	Wn0	Bus Width	Access States	Program Wait States
0	0	—	—	16	2	0
	1	0	0		3	0
			1		1	
			1		2	
			1		3	
1	0	—	—	8	2	0
	1	0	0		3	0
			1		1	
			1		2	
			1		3	

(n = 7 to 0)

### 7.3.3 Memory Interfaces

The LSI memory interfaces comprise a basic bus interface that allows direct connection of ROM, SRAM, and so on, and a burst ROM interface (for area 0 only) that allows direct connection of burst ROM.

An area for which the basic bus interface is designated functions as normal space, and an area for which the burst ROM interface is designated functions as burst ROM space.

### 7.3.4 Interface Specifications for Each Area

The initial state of each area is basic bus interface, 3-state access space. The initial bus width is selected according to the operating mode. The bus specifications described here cover basic items only, and the sections on each memory interface (7.4 and 7.5) should be referred to for further details.

**Area 0:** Area 0 includes on-chip ROM, and in ROM-disabled expansion mode, all of area 0 is external space. In ROM-enabled expansion mode, the space excluding on-chip ROM is external space.

When area 0 external space is accessed, the  $\overline{CS0}$  signal can be output.

Either basic bus interface or burst ROM interface can be selected for area 0.

**Areas 1 to 6:** In external expansion mode, all of areas 1 to 6 is external space.

When area 1 to 6 external space is accessed, the  $\overline{CS1}$  to  $\overline{CS3}$  pin signals respectively can be output.

Only the basic bus interface can be used for areas 1 to 6.

**Area 7:** Area 7 includes the on-chip RAM and internal I/O registers. In external expansion mode, the space excluding the on-chip RAM and internal I/O registers is external space. The on-chip RAM is enabled when the RAME bit in the system control register (SYSCR) is set to 1; when the RAME bit is cleared to 0, the on-chip RAM is disabled and the corresponding space becomes external space.

Only the basic bus interface can be used for the area 7.

### 7.3.5 Chip Select Signals

The LSI can output chip select signals ( $\overline{CS0}$  to  $\overline{CS3}$ ) to areas 0 to 3, the signal being driven low when the corresponding external space area is accessed.

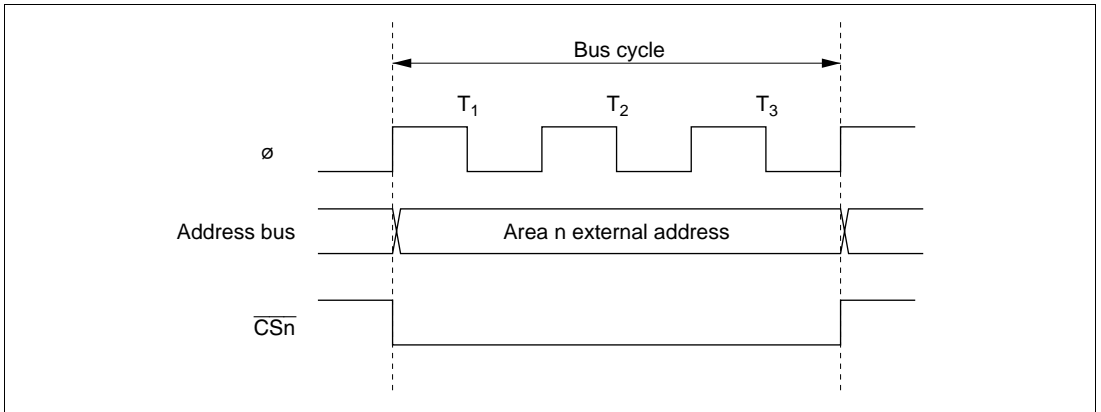
Figure 7.3 shows an example of  $\overline{CSn}$  ( $n = 0$  to 3) output timing.

Enabling or disabling of the  $\overline{CSn}$  signal is performed by setting the data direction register (DDR) for the port corresponding to the particular  $\overline{CSn}$  pin.

In ROM-disabled expansion mode, the  $\overline{CS0}$  pin is placed in the output state after a power-on reset. Pins  $\overline{CS1}$  to  $\overline{CS3}$  are placed in the input state after a power-on reset, and so the corresponding DDR should be set to 1 when outputting signals  $\overline{CS1}$  to  $\overline{CS3}$ .

In ROM-enabled expansion mode, pins  $\overline{CS0}$  to  $\overline{CS3}$  are all placed in the input state after a power-on reset, and so the corresponding DDR should be set to 1 when outputting signals  $\overline{CS0}$  to  $\overline{CS3}$ .

For details, see section 9, I/O Ports.



**Figure 7.3  $\overline{CSn}$  Signal Output Timing (n = 0 to 3)**



## 7.4 Basic Bus Interface

### 7.4.1 Overview

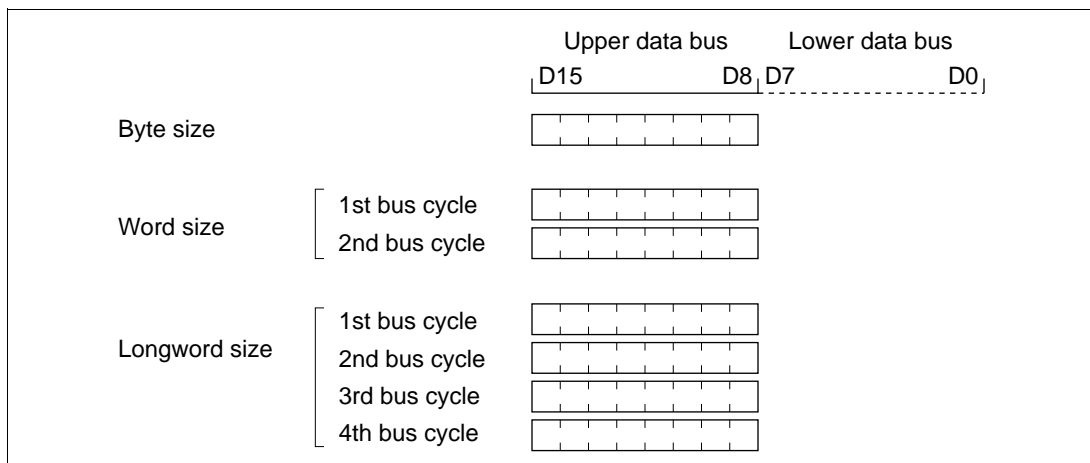
The basic bus interface enables direct connection of ROM, SRAM, and so on.

The bus specifications can be selected with ABWCR, ASTCR, WCRH, and WCRL (see table 7.3).

### 7.4.2 Data Size and Data Alignment

Data sizes for the CPU and other internal bus masters are byte, word, and longword. The bus controller has a data alignment function, and when accessing external space, controls whether the upper data bus (D15 to D8) or lower data bus (D7 to D0) is used according to the bus specifications for the area being accessed (8-bit access space or 16-bit access space) and the data size.

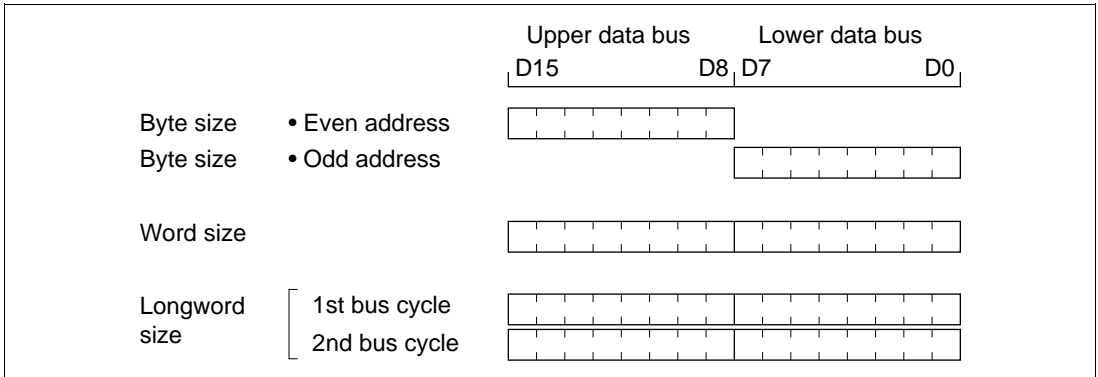
**8-Bit Access Space:** Figure 7.4 illustrates data alignment control for the 8-bit access space. With the 8-bit access space, the upper data bus (D15 to D8) is always used for accesses. The amount of data that can be accessed at one time is one byte: a word transfer instruction is performed as two byte accesses, and a longword transfer instruction, as four byte accesses.



**Figure 7.4 Access Sizes and Data Alignment Control (8-Bit Access Space)**

**16-Bit Access Space:** Figure 7.5 illustrates data alignment control for the 16-bit access space. With the 16-bit access space, the upper data bus (D15 to D8) and lower data bus (D7 to D0) are used for accesses. The amount of data that can be accessed at one time is one byte or one word, and a longword transfer instruction is executed as two word transfer instructions.

In byte access, whether the upper or lower data bus is used is determined by whether the address is even or odd. The upper data bus is used for an even address, and the lower data bus for an odd address.



**Figure 7.5 Access Sizes and Data Alignment Control (16-Bit Access Space)**

### 7.4.3 Valid Strobes

Table 7.4 shows the data buses used and valid strobes for the access spaces.

In a read, the  $\overline{RD}$  signal is valid without discrimination between the upper and lower halves of the data bus.

In a write, the  $\overline{HWR}$  signal is valid for the upper half of the data bus, and the  $\overline{LWR}$  signal for the lower half.

**Table 7.4 Data Buses Used and Valid Strobes**

Area	Access Size	Read/Write	Address	Valid Strobe	Upper Data Bus (D15 to D8)	Lower data bus (D7 to D0)
8-bit access space	Byte	Read	—	$\overline{RD}$	Valid	Invalid
		Write	—	$\overline{HWR}$		Hi-Z
16-bit access space	Byte	Read	Even	$\overline{RD}$	Valid	Invalid
			Odd		Invalid	Valid
	Write	Even	$\overline{HWR}$	Valid	Hi-Z	
		Odd	$\overline{LWR}$	Hi-Z	Valid	
Word	Read	—	$\overline{RD}$	Valid	Valid	
	Write	—	$\overline{HWR}, \overline{LWR}$	Valid	Valid	

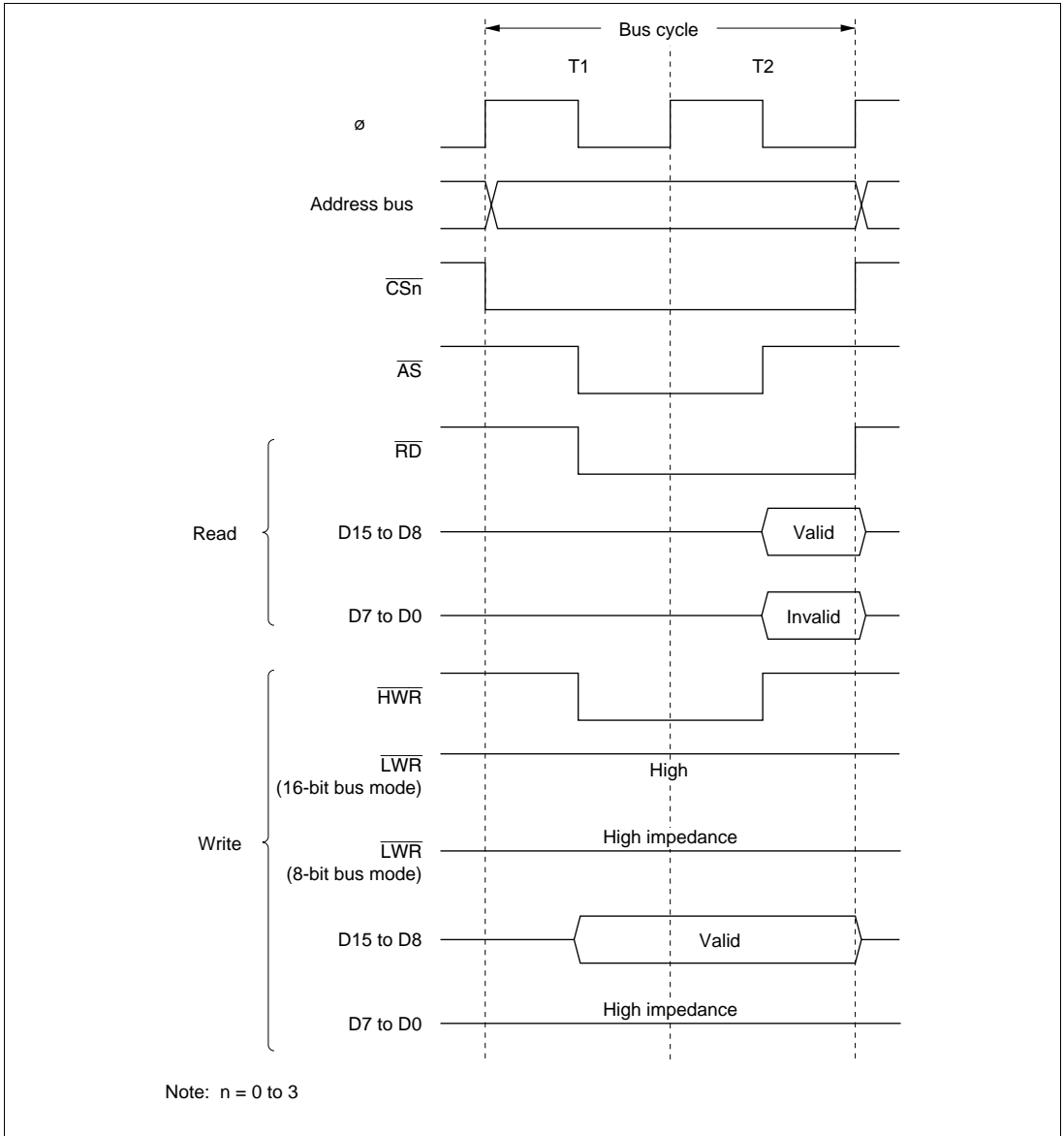
Hi-Z: High impedance.

Invalid: Input state; input value is ignored.

## 7.4.4 Basic Timing

**8-Bit 2-State Access Space:** Figure 7.6 shows the bus timing for an 8-bit 2-state access space. When an 8-bit access space is accessed, the upper half (D15 to D8) of the data bus is used.

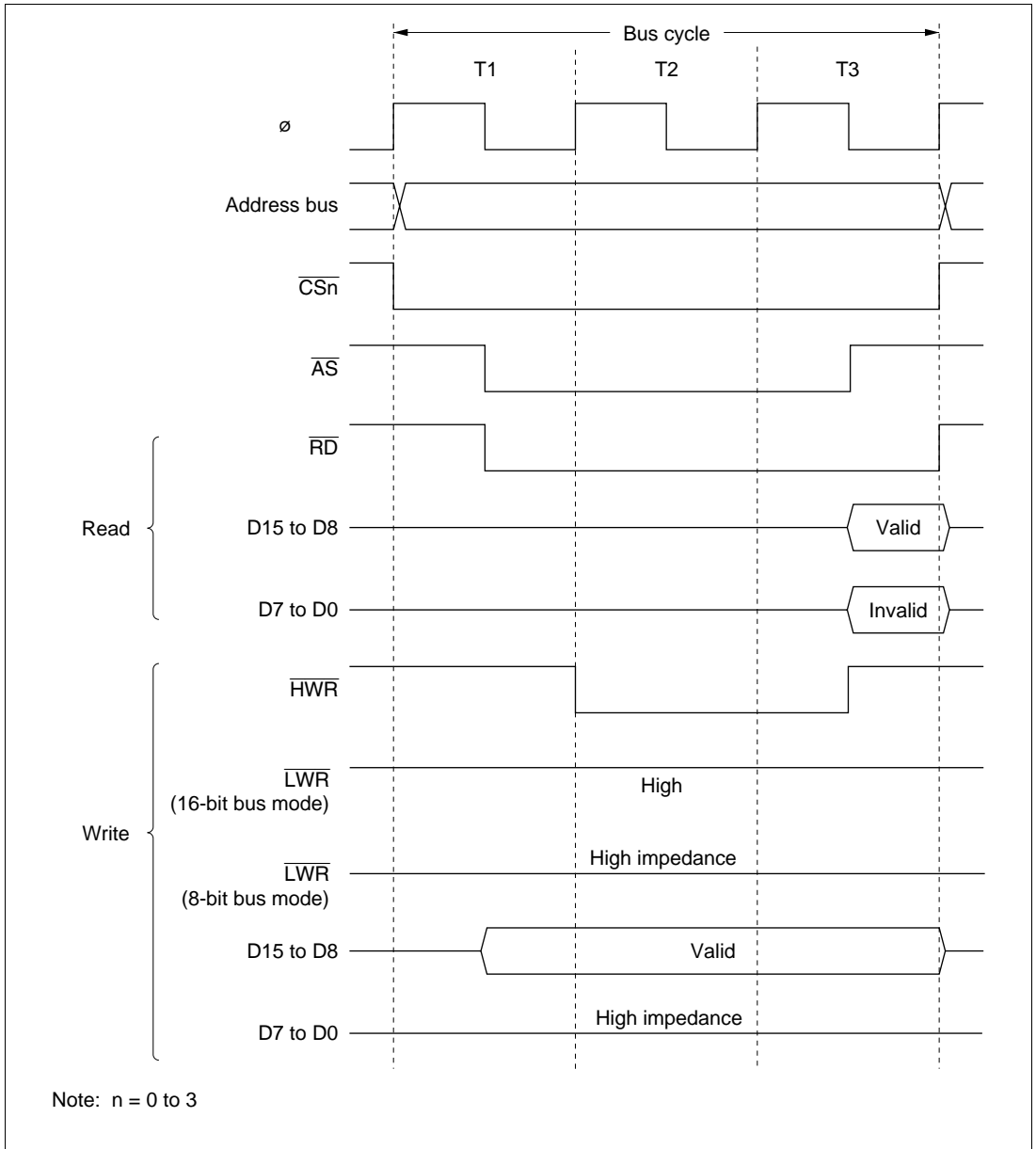
Wait states cannot be inserted.



**Figure 7.6 Bus Timing for 8-Bit 2-State Access Space**

**8-Bit 3-State Access Space:** Figure 7.7 shows the bus timing for an 8-bit 3-state access space. When an 8-bit access space is accessed, the upper half (D15 to D8) of the data bus is used.

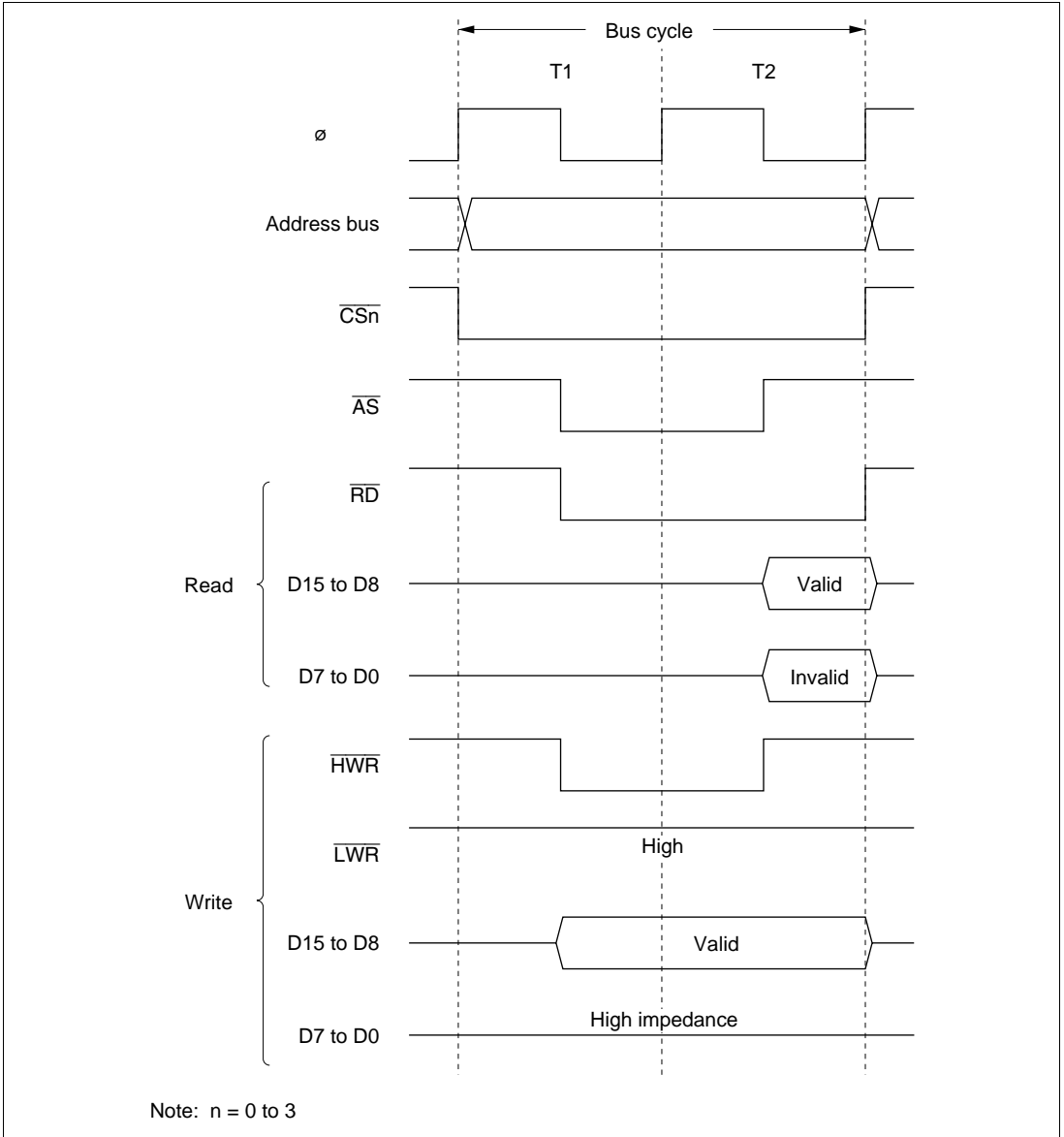
Wait states can be inserted.



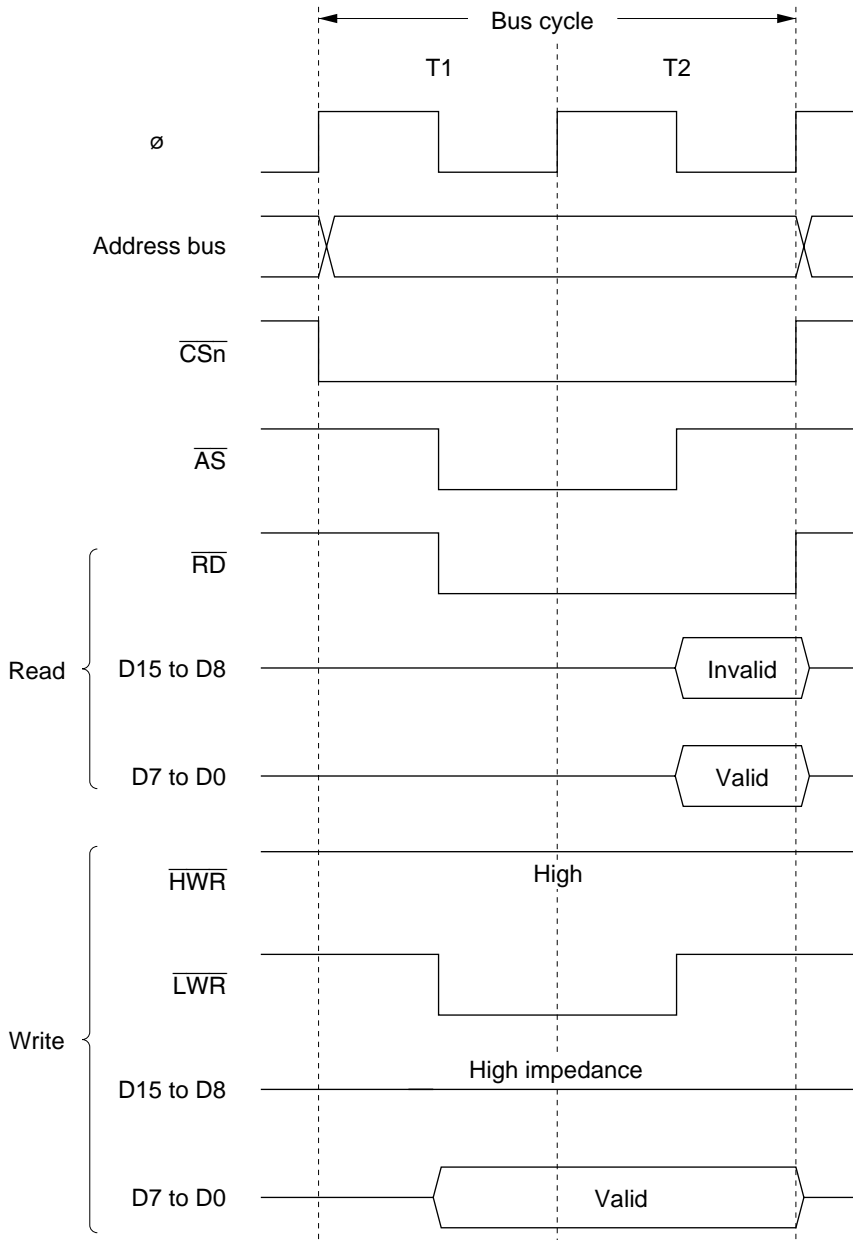
**Figure 7.7 Bus Timing for 8-Bit 3-State Access Space**

**16-Bit 2-State Access Space:** Figures 7.8 to 7.10 show bus timings for a 16-bit 2-state access space. When a 16-bit access space is accessed, the upper half (D15 to D8) of the data bus is used for the even address, and the lower half (D7 to D0) for the odd address.

Wait states cannot be inserted.

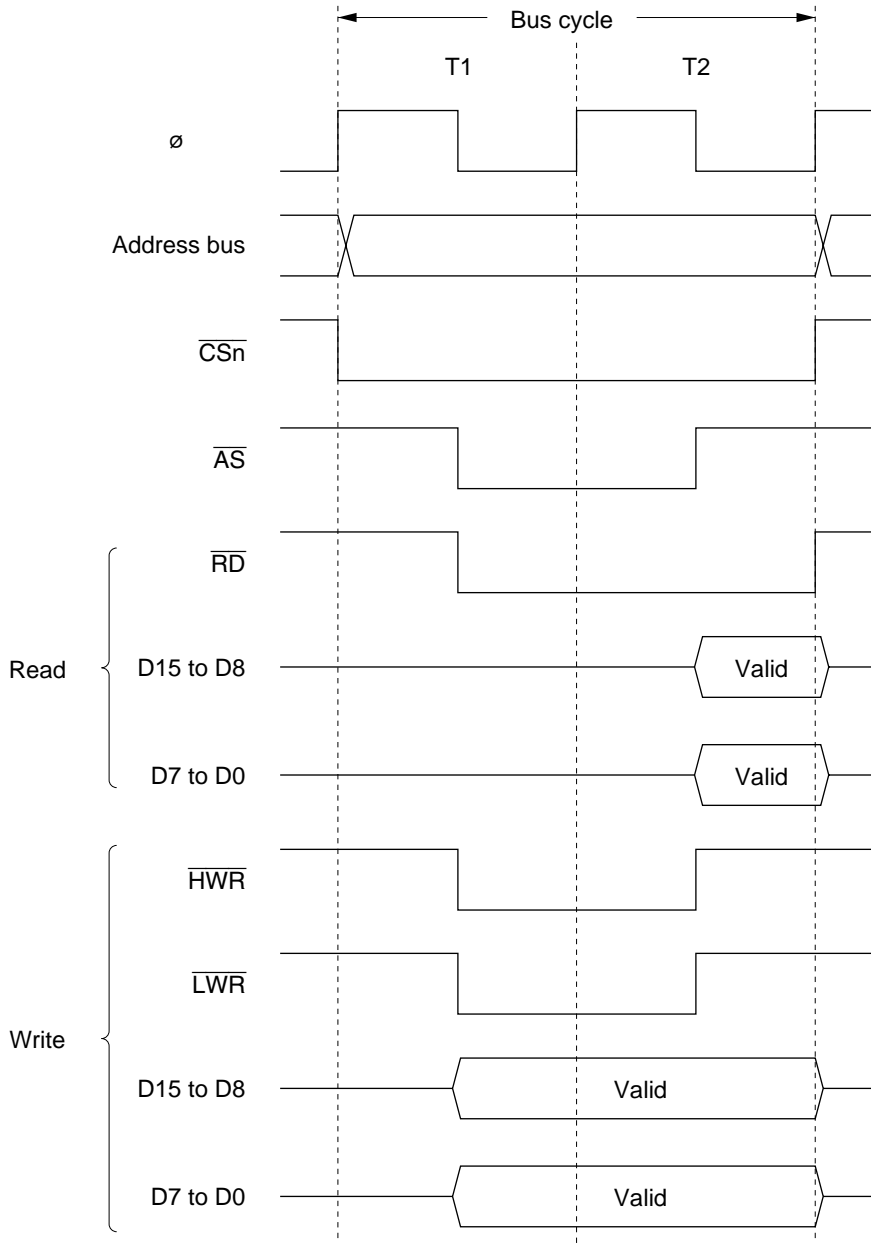


**Figure 7.8 Bus Timing for 16-Bit 2-State Access Space (Even Address Byte Access)**



Note: n = 0 to 3

Figure 7.9 Bus Timing for 16-Bit 2-State Access Space (Odd Address Byte Access)

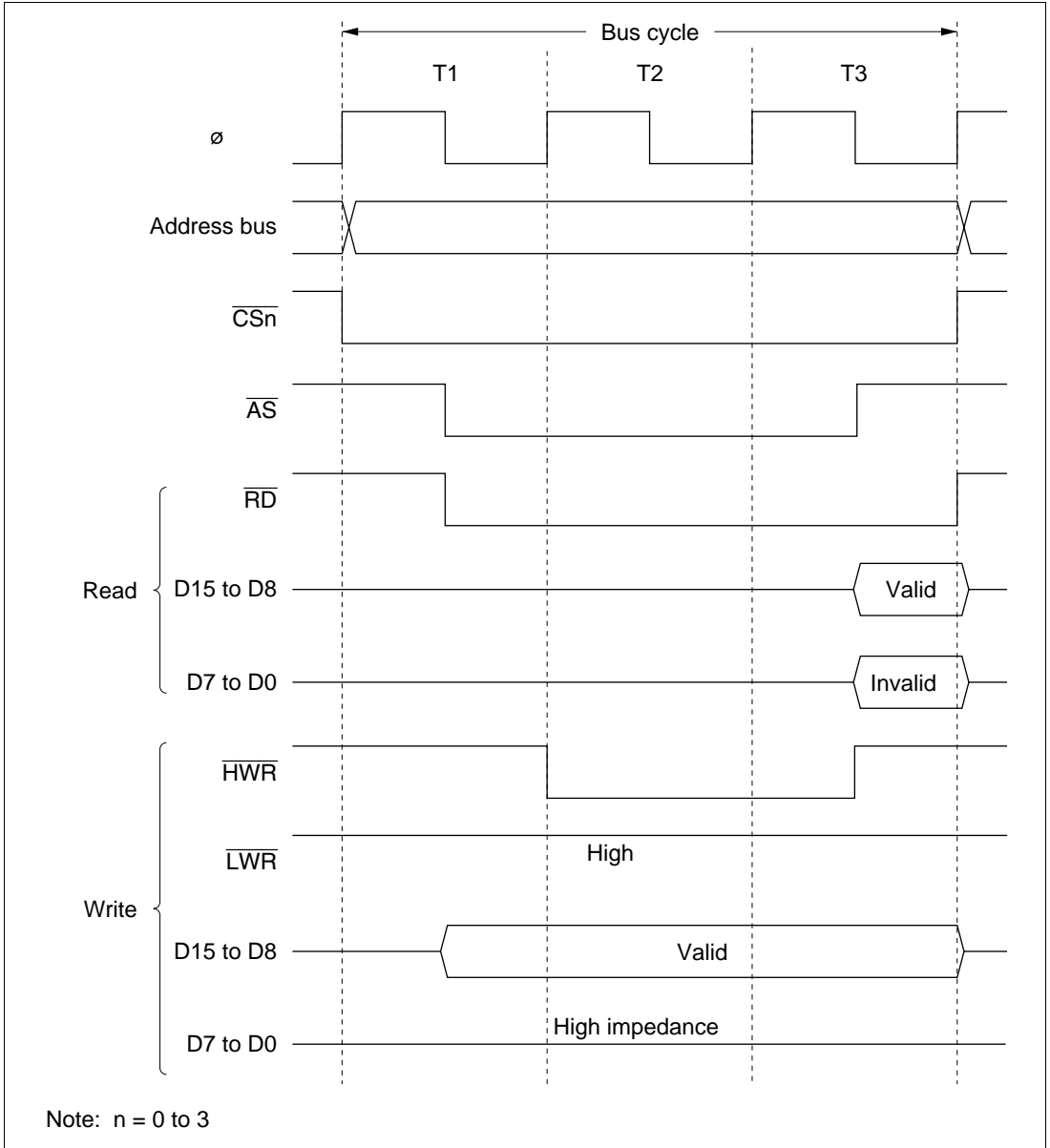


Note: n = 0 to 3

**Figure 7.10 Bus Timing for 16-Bit 2-State Access Space (Word Access)**

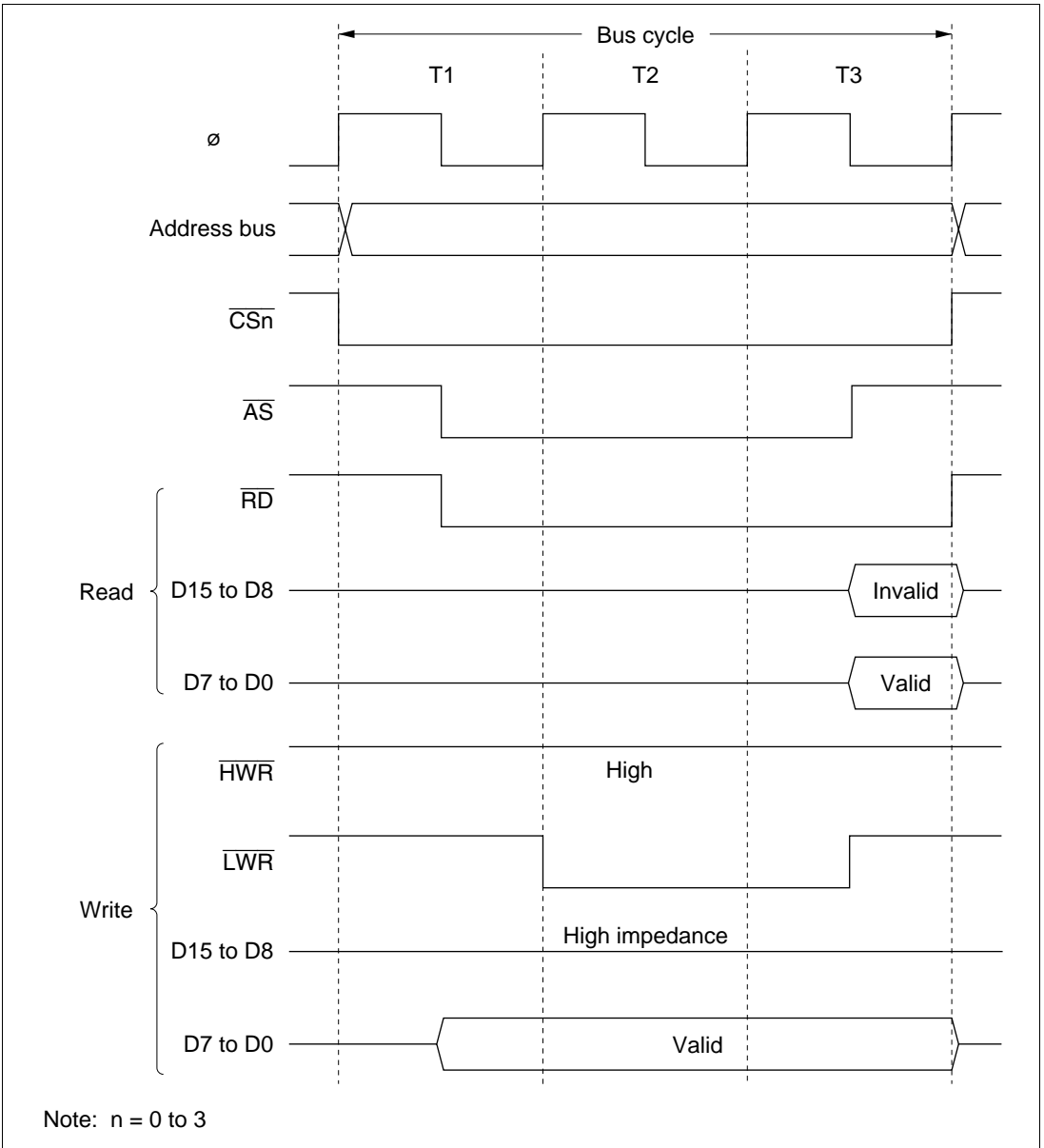
**16-Bit 3-State Access Space:** Figures 7.11 to 7.13 show bus timings for a 16-bit 3-state access space. When a 16-bit access space is accessed, the upper half (D15 to D8) of the data bus is used for the even address, and the lower half (D7 to D0) for the odd address.

Wait states can be inserted.

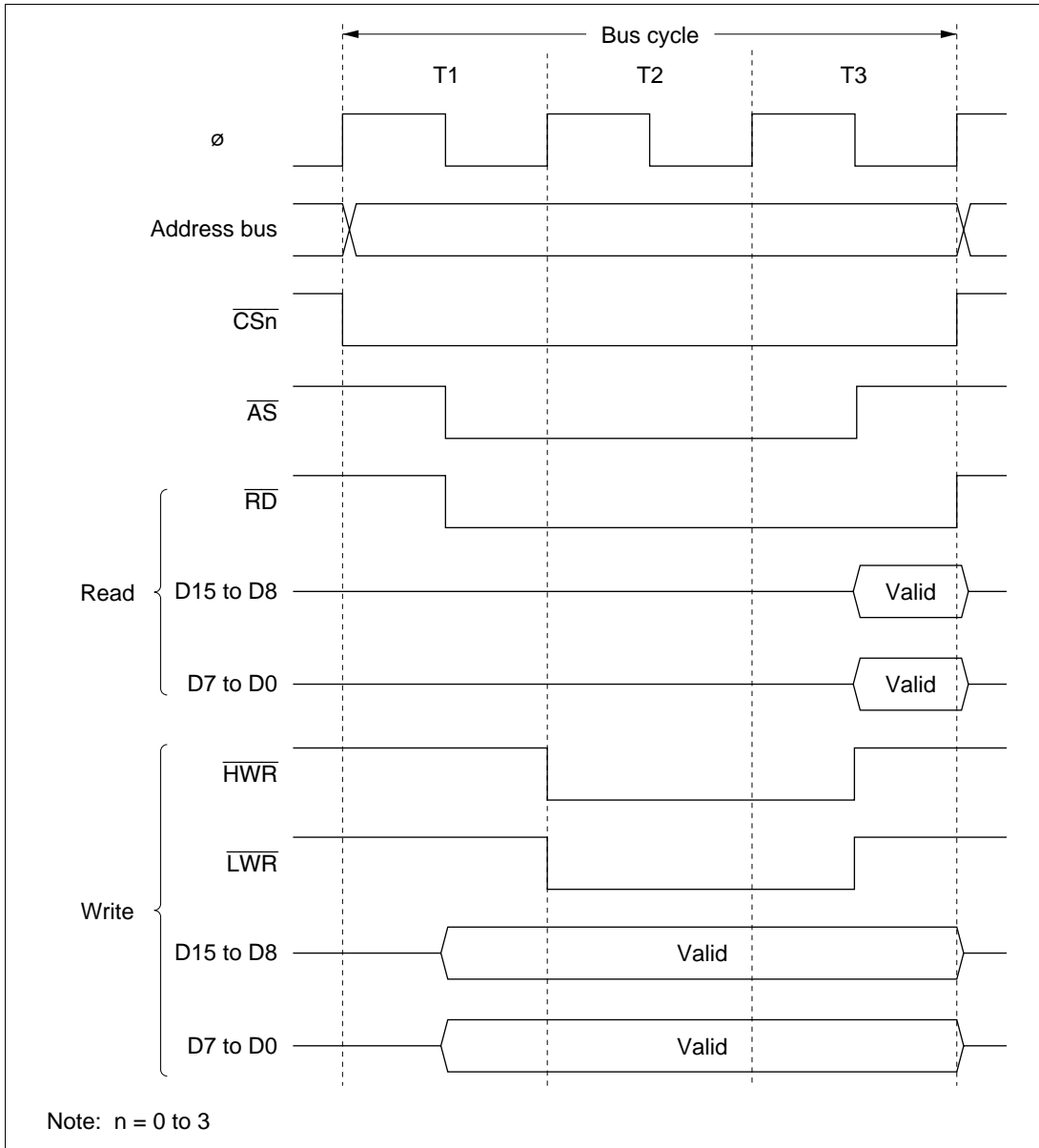


**Figure 7.11 Bus Timing for 16-Bit 3-State Access Space (Even Address Byte Access)**





**Figure 7.12 Bus Timing for 16-Bit 3-State Access Space (Odd Address Byte Access)**



**Figure 7.13 Bus Timing for 16-Bit 3-State Access Space (Word Access)**

## 7.4.5 Wait Control

When accessing external space, the LSI can extend the bus cycle by inserting one or more wait states ( $T_w$ ). There are two ways of inserting wait states: program wait insertion and pin wait insertion using the  $\overline{\text{WAIT}}$  pin.

### Program Wait Insertion

From 0 to 3 wait states can be inserted automatically between the T2 state and T3 state on an individual area basis in 3-state access space, according to the settings of WCRH and WCRL.

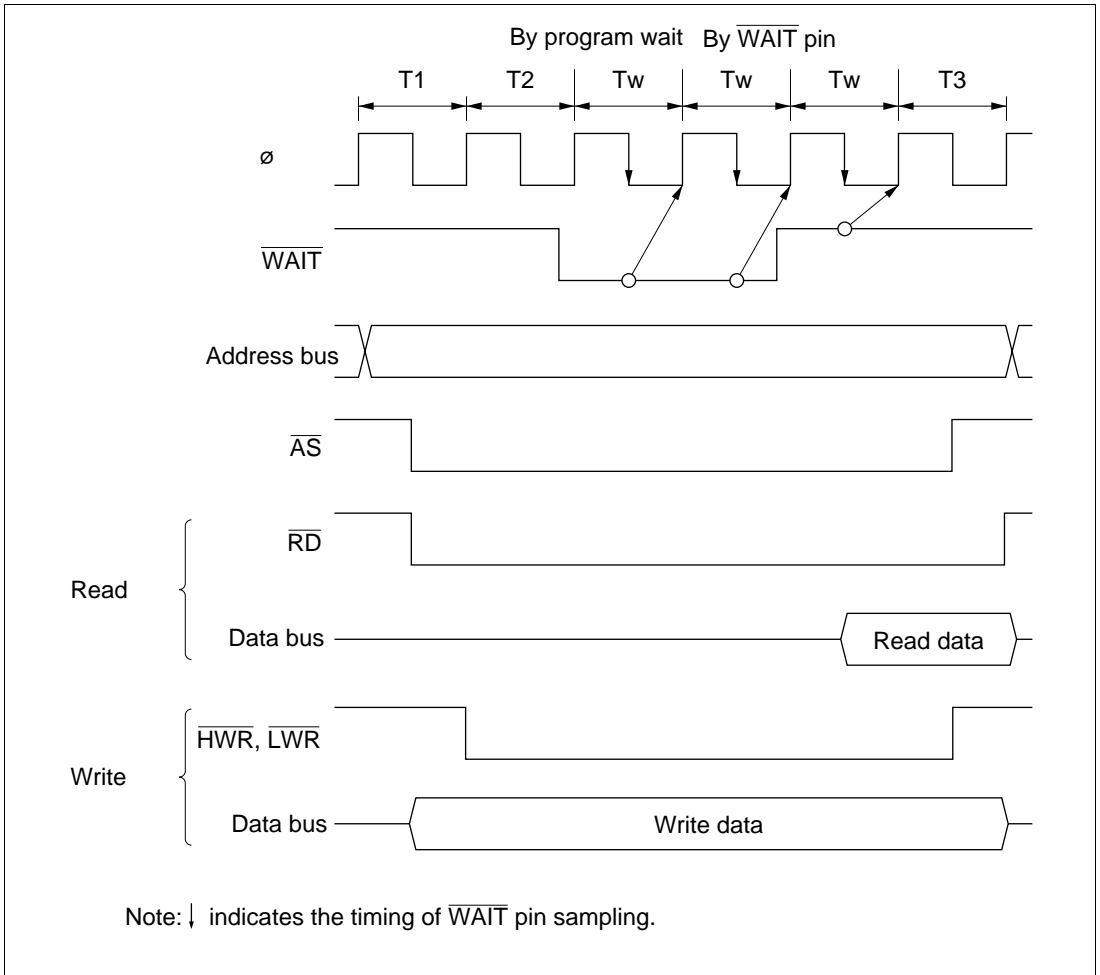
### Pin Wait Insertion

Setting the WAITE bit in BCRH to 1 enables wait insertion by means of the  $\overline{\text{WAIT}}$  pin. When external space is accessed in this state, program wait insertion is first carried out according to the settings in WCRH and WCRL. Then, if the  $\overline{\text{WAIT}}$  pin is low at the falling edge of  $\phi$  in the last T2 or  $T_w$  state, a  $T_w$  state is inserted. If the  $\overline{\text{WAIT}}$  pin is held low,  $T_w$  states are inserted until it goes high.

This is useful when inserting four or more  $T_w$  states, or when changing the number of  $T_w$  states for different external devices.

The WAITE bit setting applies to all areas.

Figure 7.14 shows an example of wait state insertion timing.



**Figure 7.14 Example of Wait State Insertion Timing**

The settings after a power-on reset are: 3-state access, 3 program wait state insertion, and  $\overline{\text{WAIT}}$  input disabled.

## 7.5 Burst ROM Interface

### 7.5.1 Overview

With the LSI, external space area 0 can be designated as burst ROM space, and burst ROM interfacing can be performed. The burst ROM space interface enables 16-bit configuration ROM with burst access capability to be accessed at high speed.

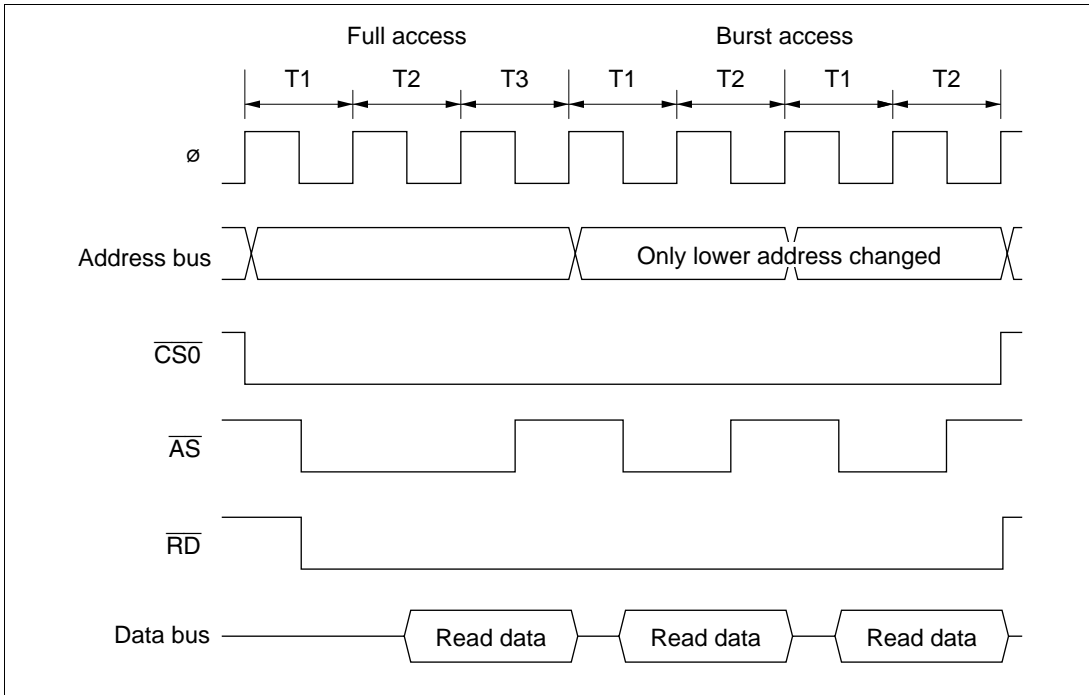
Area 0 can be designated as burst ROM space by means of the BRSTRM bit in BCRH. Consecutive burst accesses of a maximum of 4 words or 8 words can be performed for CPU instruction fetches only. One or two states can be selected for burst access.

### 7.5.2 Basic Timing

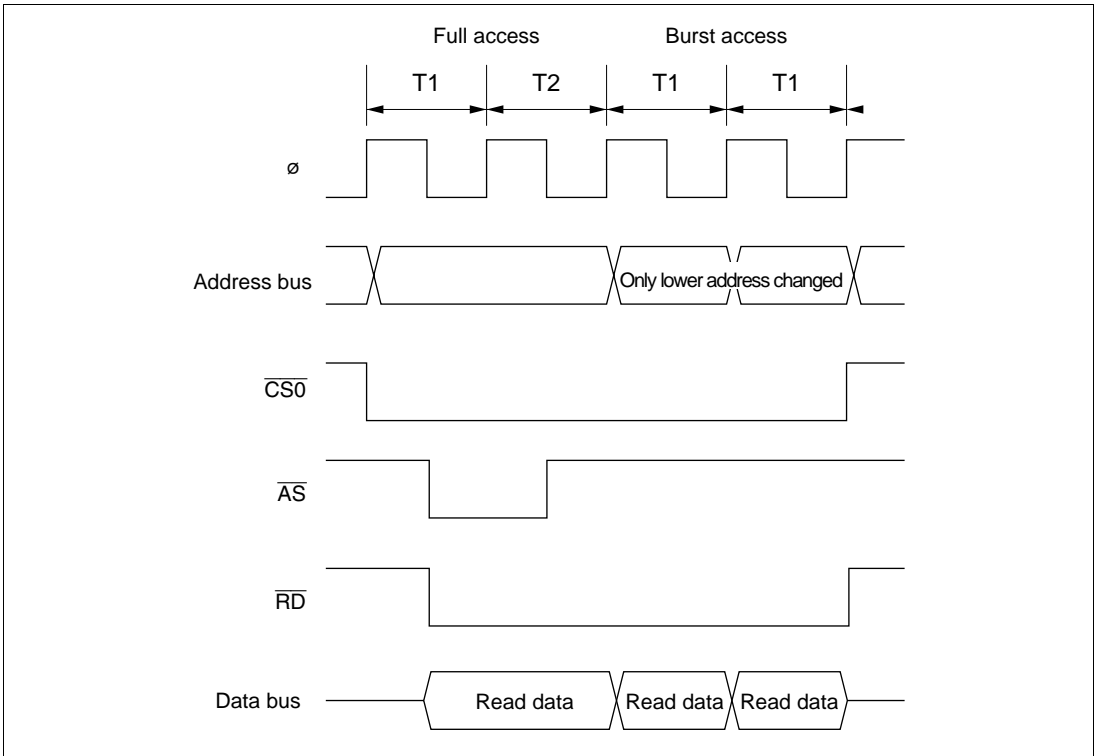
The number of states in the initial cycle (full access) of the burst ROM interface is in accordance with the setting of the AST0 bit in ASTCR. Also, when the AST0 bit is set to 1, wait state insertion is possible. One or two states can be selected for the burst cycle, according to the setting of the BRSTS1 bit in BCRH. Wait states cannot be inserted. When area 0 is designated as burst ROM space, it becomes 16-bit access space regardless of the setting of the ABW0 bit in ABWCR.

When the BRSTS0 bit in BCRH is cleared to 0, burst access of up to 4 words is performed; when the BRSTS0 bit is set to 1, burst access of up to 8 words is performed.

The basic access timing for burst ROM space is shown in figures 7.15 (a) and (b). The timing shown in figure 7.15 (a) is for the case where the AST0 and BRSTS1 bits are both set to 1, and that in figure 7.15 (b) is for the case where both these bits are cleared to 0.



**Figure 7.15 (a) Example of Burst ROM Access Timing (When AST0 = BRSTS1 = 1)**



**Figure 7.15 (b) Example of Burst ROM Access Timing (When  $AST0 = BRSTS1 = 0$ )**

### 7.5.3 Wait Control

As with the basic bus interface, either program wait insertion or pin wait insertion using the  $\overline{WAIT}$  pin can be used in the initial cycle (full access) of the burst ROM interface. See section 7.4.5, Wait Control.

Wait states cannot be inserted in a burst cycle.

## 7.6 Idle Cycle

### 7.6.1 Operation

When the LSI accesses external space, it can insert a 1-state idle cycle ( $T_1$ ) between bus cycles in the following two cases: (1) when read accesses between different areas occur consecutively, and (2) when a write cycle occurs immediately after a read cycle. By inserting an idle cycle it is possible, for example, to avoid data collisions between ROM, with a long output floating time, and high-speed memory, I/O interfaces, and so on.

#### (1) Consecutive Reads between Different Areas

If consecutive reads between different areas occur while the ICIS1 bit in BCRH is set to 1, an idle cycle is inserted at the start of the second read cycle.

Figure 7.16 shows an example of the operation in this case. In this example, bus cycle A is a read cycle from ROM with a long output floating time, and bus cycle B is a read cycle from SRAM, each being located in a different area. In (a), an idle cycle is not inserted, and a collision occurs in cycle B between the read data from ROM and that from SRAM. In (b), an idle cycle is inserted, and a data collision is prevented.

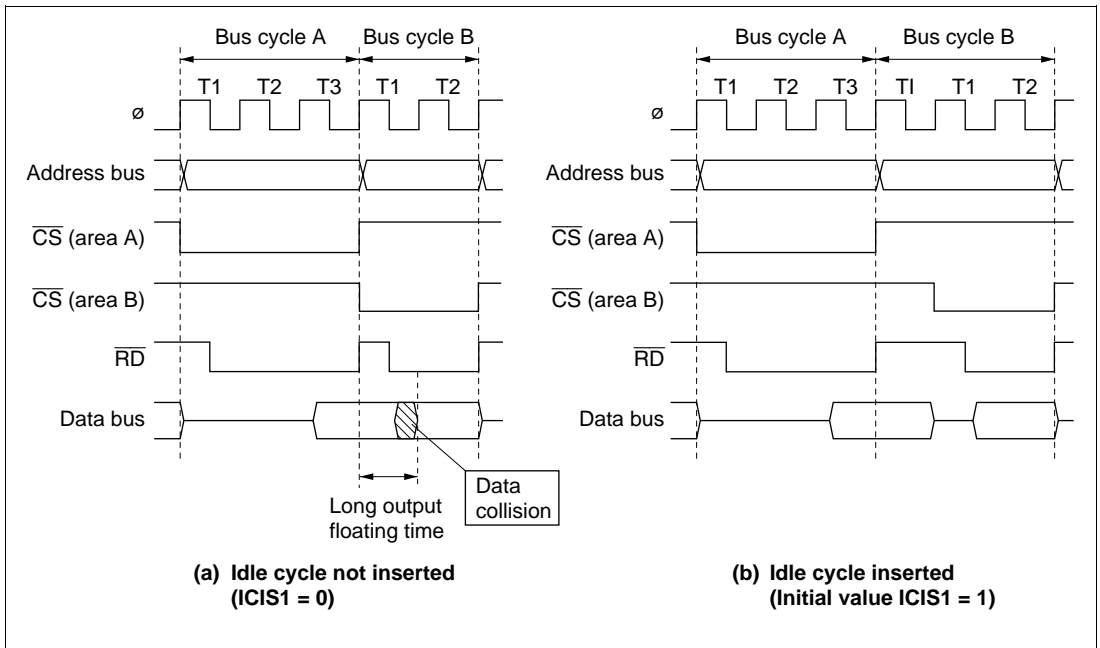


Figure 7.16 Example of Idle Cycle Operation (1)



## (2) Write after Read

If an external write occurs after an external read while the ICIS0 bit in BCRH is set to 1, an idle cycle is inserted at the start of the write cycle.

Figure 7.17 shows an example of the operation in this case. In this example, bus cycle A is a read cycle from ROM with a long output floating time, and bus cycle B is a CPU write cycle. In (a), an idle cycle is not inserted, and a collision occurs in cycle B between the read data from ROM and the CPU write data. In (b), an idle cycle is inserted, and a data collision is prevented.

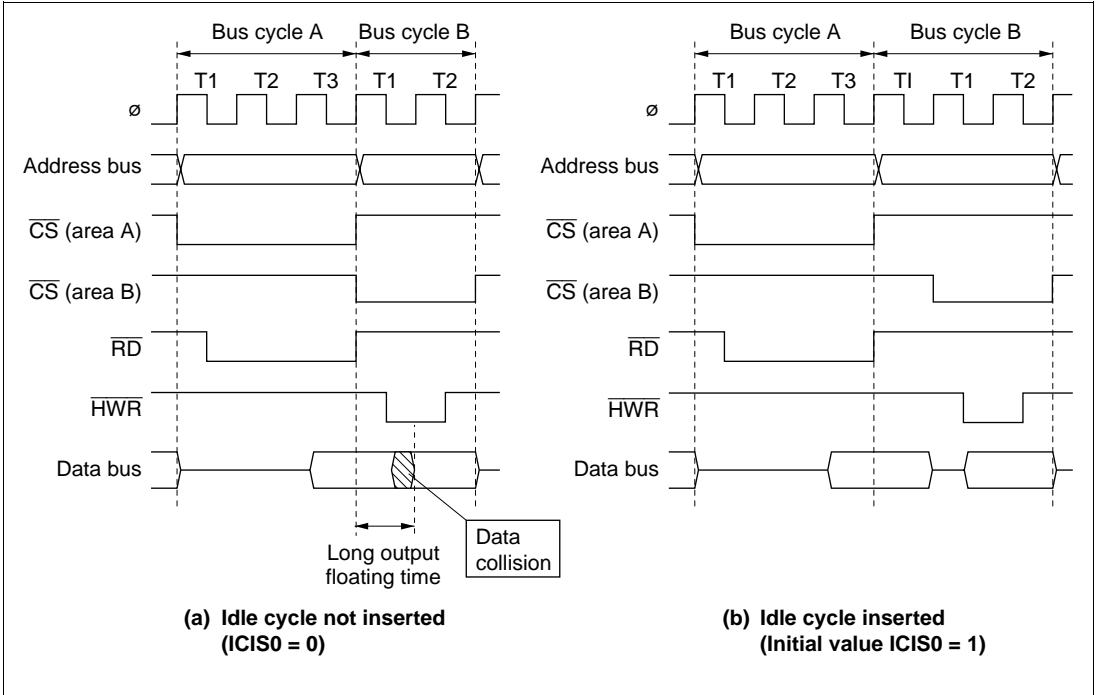


Figure 7.17 Example of Idle Cycle Operation (2)

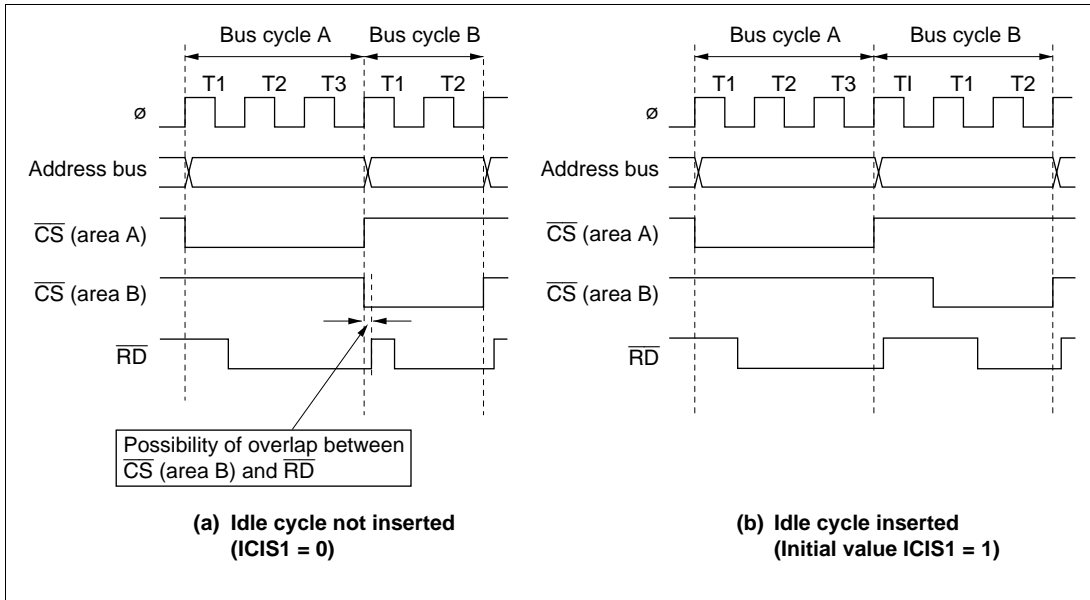
## (3) Relationship between Chip Select ( $\overline{CS}$ ) Signal and Read ( $\overline{RD}$ ) Signal

Depending on the system's load conditions, the  $\overline{RD}$  signal may lag behind the  $\overline{CS}$  signal. An example is shown in figure 7.18.

In this case, with the setting for no idle cycle insertion (a), there may be a period of overlap between the bus cycle A  $\overline{RD}$  signal and the bus cycle B  $\overline{CS}$  signal.

Setting idle cycle insertion, as in (b), however, will prevent any overlap between the  $\overline{RD}$  and  $\overline{CS}$  signals.

In the initial state after reset release, idle cycle insertion (b) is set.



**Figure 7.18 Relationship between Chip Select ( $\overline{CS}$ ) and Read ( $\overline{RD}$ )**

## 7.6.2 Pin States in Idle Cycle

Table 7.5 shows pin states in an idle cycle.

**Table 7.5 Pin States in Idle Cycle**

<b>Pins</b>	<b>Pin State</b>
A23 to A0	Contents of next bus cycle
D15 to D0	High impedance
$\overline{CS}_n$	High
$\overline{AS}$	High
$\overline{RD}$	High
HWR	High
LWR	High

(n = 0 to 3)

## 7.7 Bus Release

### 7.7.1 Overview

The LSI can release the external bus in response to a bus request from an external device. In the external bus released state, the internal bus master continues to operate as long as there is no external access.

### 7.7.2 Operation

In external expansion mode, the bus can be released to an external device by setting the BRLE bit in BCRL to 1. Driving the  $\overline{\text{BREQ}}$  pin low issues an external bus request to the LSI. When the  $\overline{\text{BREQ}}$  pin is sampled, at the prescribed timing the  $\overline{\text{BACK}}$  pin is driven low, and the address bus, data bus, and bus control signals are placed in the high-impedance state, establishing the external bus-released state.

In the external bus released state, an internal bus master can perform accesses using the internal bus. When an internal bus master wants to make an external access, it temporarily defers activation of the bus cycle, and waits for the bus request from the external bus master to be dropped.

When the  $\overline{\text{BREQ}}$  pin is driven high, the  $\overline{\text{BACK}}$  pin is driven high at the prescribed timing and the external bus released state is terminated.

In the event of simultaneous external bus release request and external access request generation, the order of priority is as follows:

(High) External bus release > Internal bus master external access (Low)

### 7.7.3 Pin States in External Bus Released State

Table 7.6 shows pin states in the external bus released state.

**Table 7.6 Pin States in Bus Released State**

<b>Pins</b>	<b>Pin State</b>
A23 to A0	High impedance
D15 to D0	High impedance
$\overline{\text{CS}}_n$	High impedance
$\overline{\text{AS}}$	High impedance
$\overline{\text{RD}}$	High impedance
$\overline{\text{HWR}}$	High impedance
$\overline{\text{LWR}}$	High impedance

(n = 0 to 3)

## 7.7.4 Transition Timing

Figure 7.19 shows the timing for transition to the bus-released state.

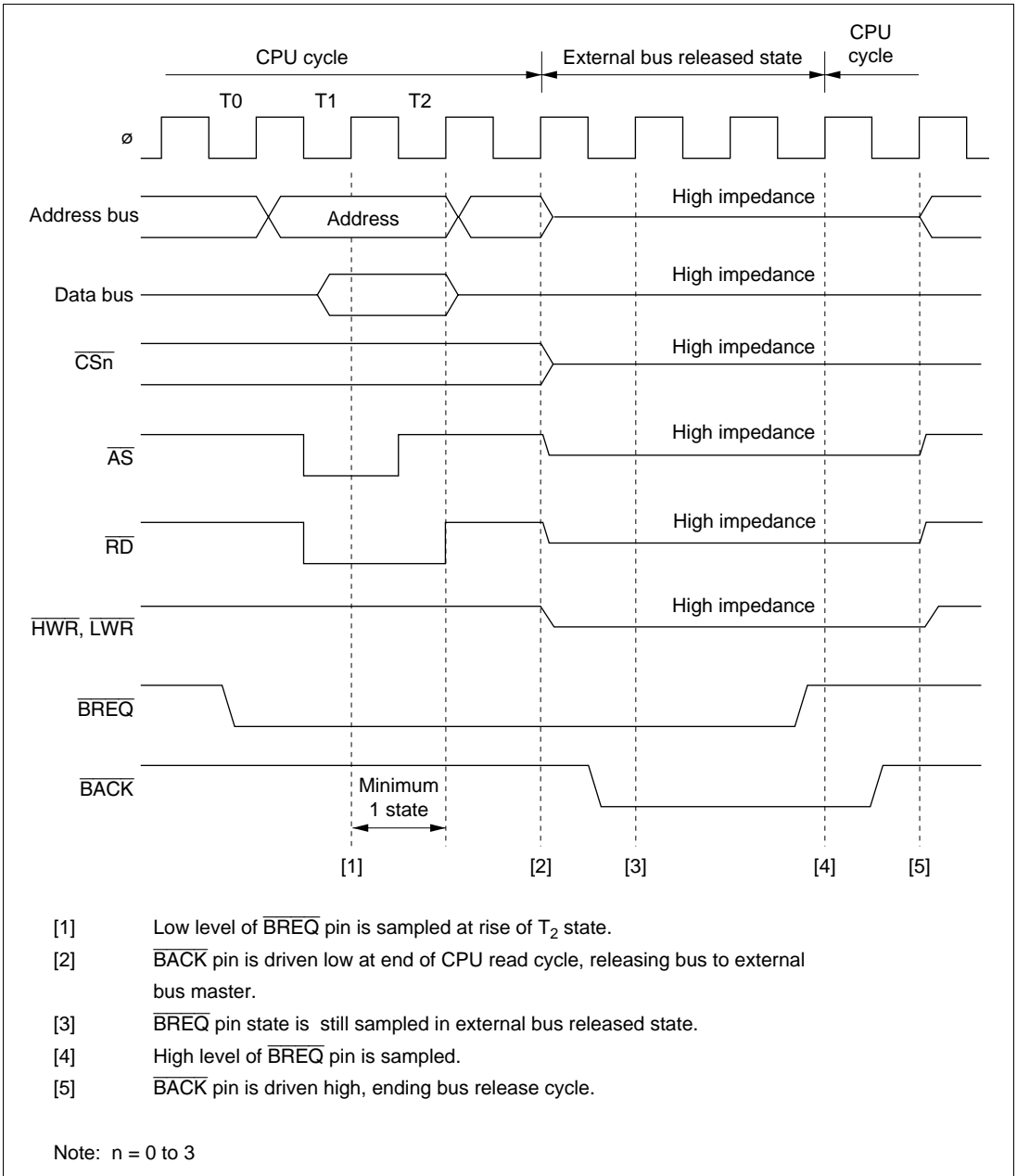


Figure 7.19 Bus-Released State Transition Timing

### 7.7.5 Usage Note

When MSTPCR is set to H'FFFFFF and a transition is made to sleep mode, the external bus release function halts. Therefore, MSTPCR should not be set to H'FFFFFF if the external bus release function is to be used in sleep mode.

## 7.8 Bus Arbitration

### 7.8.1 Overview

The LSI has a bus arbiter that arbitrates bus master operations.

There are two bus masters, the CPU and DTC, which perform read/write operations when they have possession of the bus. Each bus master requests the bus by means of a bus request signal. The bus arbiter determines priorities at the prescribed timing, and permits use of the bus by means of a bus request acknowledge signal. The selected bus master then takes possession of the bus and begins its operation.

### 7.8.2 Operation

The bus arbiter detects the bus masters' bus request signals, and if the bus is requested, sends a bus request acknowledge signal to the bus master making the request. If there are bus requests from more than one bus master, the bus request acknowledge signal is sent to the one with the highest priority. When a bus master receives the bus request acknowledge signal, it takes possession of the bus until that signal is canceled.

The order of priority of the bus masters is as follows:

(High) DTC > CPU (Low)

An internal bus access by an internal bus master, and external bus release, can be executed in parallel.

In the event of simultaneous external bus release request, and internal bus master external access request generation, the order of priority is as follows:

(High) External bus release > Internal bus master external access (Low)

### 7.8.3 Bus Transfer Timing

Even if a bus request is received from a bus master with a higher priority than that of the bus master that has acquired the bus and is currently operating, the bus is not necessarily transferred immediately. There are specific times at which each bus master can relinquish the bus.

**CPU:** The CPU is the lowest-priority bus master, and if a bus request is received from the DTC, the bus arbiter transfers the bus to the bus master that issued the request. The timing for transfer of the bus is as follows:

- The bus is transferred at a break between bus cycles. However, if a bus cycle is executed in discrete operations, as in the case of a longword-size access, the bus is not transferred between the operations. See Appendix A.5, Bus States During Instruction Execution, for timings at which the bus is not transferred.
- If the CPU is in sleep mode, it transfers the bus immediately.

**DTC:** The DTC sends the bus arbiter a request for the bus when an activation request is generated.

The DTC can release the bus after a vector read, a register information read (3 states), a single data transfer, or a register information write (3 states). It does not release the bus during a register information read (3 states), a single data transfer, or a register information write (3 states).

### 7.8.4 External Bus Release Usage Note

External bus release can be performed on completion of an external bus cycle. The  $\overline{CS}$  signal remains low until the end of the external bus cycle. Therefore, when external bus release is performed, the  $\overline{CS}$  signal may change from the low level to the high-impedance state.

## 7.9 Resets and the Bus Controller

In a power-on reset, the LSI, including the bus controller, enters the reset state at that point, and an executing bus cycle is discontinued.





# Section 8 Data Transfer Controller (DTC)

## 8.1 Overview

The LSI includes a data transfer controller (DTC). The DTC can be activated by an interrupt or software, to transfer data.

### 8.1.1 Features

The features of the DTC are:

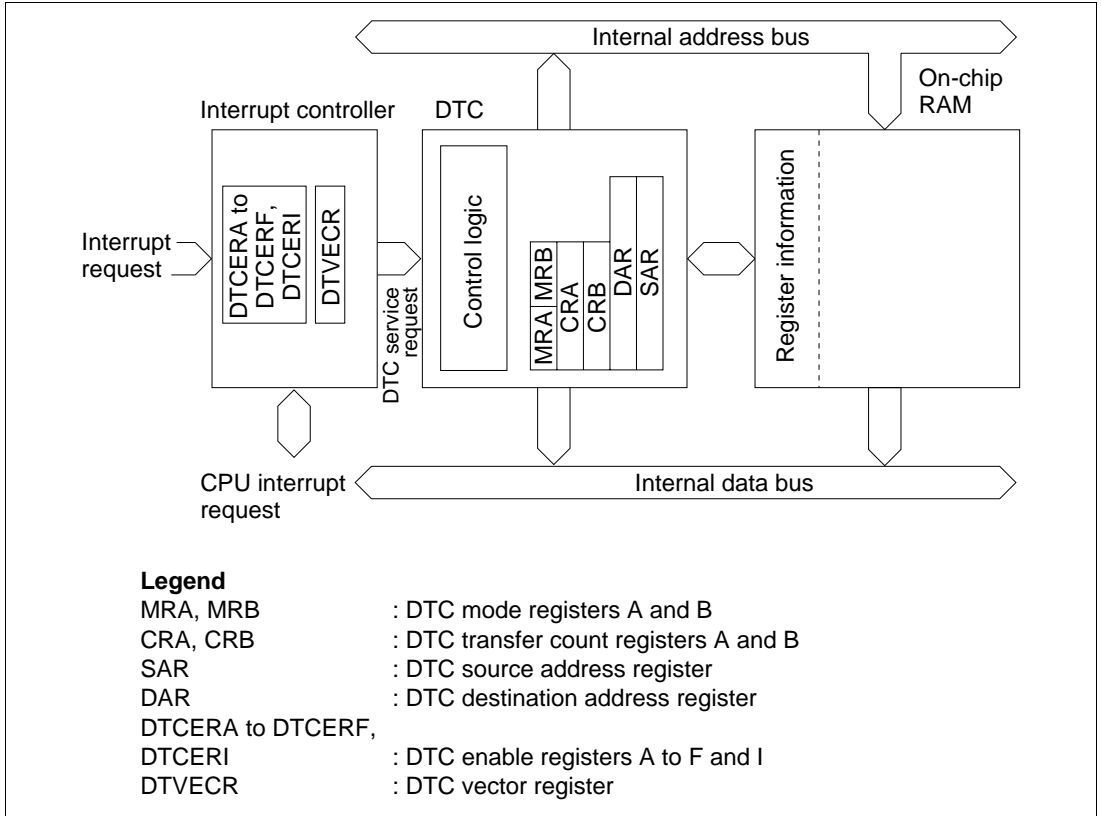
- Transfer possible over any number of channels
  - Transfer information is stored in memory
  - One activation source can trigger a number of data transfers (chain transfer)
- Wide range of transfer modes
  - Normal, repeat, and block transfer modes available
  - Incrementing, decrementing, and fixing of source and destination addresses can be selected
- Direct specification of 16-Mbyte address space possible
  - 24-bit transfer source and destination addresses can be specified
- Transfer can be set in byte or word units
- A CPU interrupt can be requested for the interrupt that activated the DTC
  - An interrupt request can be issued to the CPU after one data transfer ends
  - An interrupt request can be issued to the CPU after the specified data transfers have completely ended
- Activation by software is possible
- Module stop mode can be set
  - The initial setting enables DTC registers to be accessed. DTC operation is halted by setting module stop mode.

## 8.1.2 Block Diagram

Figure 8.1 shows a block diagram of the DTC.

The DTC's register information is stored in the on-chip RAM\*. A 32-bit bus connects the DTC to the on-chip RAM (1 kbyte), enabling 32-bit/1-state reading and writing of the DTC register information.

Note: \* When the DTC is used, the RAME bit in SYSCR must be set to 1.



**Figure 8.1 Block Diagram of DTC**

### 8.1.3 Register Configuration

Table 8.1 summarizes the DTC registers.

**Table 8.1 DTC Registers**

<b>Name</b>	<b>Abbreviation</b>	<b>R/W</b>	<b>Initial Value</b>	<b>Address*<sup>1</sup></b>
DTC mode register A	MRA	—* <sup>2</sup>	Undefined	—* <sup>3</sup>
DTC mode register B	MRB	—* <sup>2</sup>	Undefined	—* <sup>3</sup>
DTC source address register	SAR	—* <sup>2</sup>	Undefined	—* <sup>3</sup>
DTC destination address register	DAR	—* <sup>2</sup>	Undefined	—* <sup>3</sup>
DTC transfer count register A	CRA	—* <sup>2</sup>	Undefined	—* <sup>3</sup>
DTC transfer count register B	CRB	—* <sup>2</sup>	Undefined	—* <sup>3</sup>
DTC enable registers	DTCER	R/W	H'00	H'FE16 to H'FE1A, H'FE1E
DTC vector register	DTVECR	R/W	H'00	H'FE1F
Module stop control register A	MSTPCRA	R/W	H'3F	H'FDE8

Notes: \*1 Lower 16 bits of the address.

\*2 Registers within the DTC cannot be read or written to directly.

\*3 Register information is located in on-chip RAM addresses H'EBC0 to H'EFBF. It cannot be located in external memory space. When the DTC is used, do not clear the RAME bit in SYSCR to 0.

## 8.2 Register Descriptions

### 8.2.1 DTC Mode Register A (MRA)

Bit	:	7	6	5	4	3	2	1	0
		SM1	SM0	DM1	DM0	MD1	MD0	DTS	Sz
Initial value	:	Unde- fined	Unde- fined	Unde- fined	Unde- fined	Unde- fined	Unde- fined	Unde- fined	Unde- fined
R/W	:	—	—	—	—	—	—	—	—

MRA is an 8-bit register that controls the DTC operating mode.

**Bits 7 and 6—Source Address Mode 1 and 0 (SM1, SM0):** These bits specify whether SAR is to be incremented, decremented, or left fixed after a data transfer.

Bit 7	Bit 6	Description
SM1	SM0	
0	—	SAR is fixed
1	0	SAR is incremented after a transfer (by +1 when Sz = 0; by +2 when Sz = 1)
	1	SAR is decremented after a transfer (by -1 when Sz = 0; by -2 when Sz = 1)

**Bits 5 and 4—Destination Address Mode 1 and 0 (DM1, DM0):** These bits specify whether DAR is to be incremented, decremented, or left fixed after a data transfer.

Bit 5	Bit 4	Description
DM1	DM0	
0	—	DAR is fixed
1	0	DAR is incremented after a transfer (by +1 when Sz = 0; by +2 when Sz = 1)
	1	DAR is decremented after a transfer (by -1 when Sz = 0; by -2 when Sz = 1)

**Bits 3 and 2—DTC Mode (MD1, MD0):** These bits specify the DTC transfer mode.

Bit 3	Bit 2	
MD1	MD0	Description
0	0	Normal mode
	1	Repeat mode
1	0	Block transfer mode
	1	—

**Bit 1—DTC Transfer Mode Select (DTS):** Specifies whether the source side or the destination side is set to be a repeat area or block area, in repeat mode or block transfer mode.

**Bit 1**

DTS	Description
0	Destination side is repeat area or block area
1	Source side is repeat area or block area

**Bit 0—DTC Data Transfer Size (Sz):** Specifies the size of data to be transferred.

**Bit 0**

Sz	Description
0	Byte-size transfer
1	Word-size transfer

## 8.2.2 DTC Mode Register B (MRB)

Bit	:	7	6	5	4	3	2	1	0
		CHNE	DISEL	—	—	—	—	—	—
Initial value:		Unde- fined	Unde- fined	Unde- fined	Unde- fined	Unde- fined	Unde- fined	Unde- fined	Unde- fined
R/W	:	—	—	—	—	—	—	—	—

MRB is an 8-bit register that controls the DTC operating mode.

**Bit 7—DTC Chain Transfer Enable (CHNE):** Specifies chain transfer. With chain transfer, a number of data transfers can be performed consecutively in response to a single transfer request.

In data transfer with CHNE set to 1, determination of the end of the specified number of transfers, clearing of the interrupt source flag, and clearing of DTCER is not performed.

#### Bit 7

CHNE	Description
0	End of DTC data transfer (activation waiting state is entered)
1	DTC chain transfer (new register information is read, then data is transferred)

**Bit 6—DTC Interrupt Select (DISEL):** Specifies whether interrupt requests to the CPU are disabled or enabled after a data transfer.

#### Bit 6

DISEL	Description
0	After a data transfer ends, the CPU interrupt is disabled unless the transfer counter is 0 (the DTC clears the interrupt source flag of the activating interrupt to 0)
1	After a data transfer ends, the CPU interrupt is enabled (the DTC does not clear the interrupt source flag of the activating interrupt to 0)

**Bits 5 to 0—Reserved:** These bits have no effect on DTC operation in the LSI, and should always be written with 0.

### 8.2.3 DTC Source Address Register (SAR)

Bit	:	23	22	21	20	19	---	4	3	2	1	0
		<input type="checkbox"/>	<input type="checkbox"/>	<input type="checkbox"/>	<input type="checkbox"/>	<input type="checkbox"/>	<input type="checkbox"/>	<input type="checkbox"/>	<input type="checkbox"/>	<input type="checkbox"/>	<input type="checkbox"/>	<input type="checkbox"/>
Initial value:		Unde-	Unde-	Unde-	Unde-	Unde-	---	Unde-	Unde-	Unde-	Unde-	Unde-
		fin-	fin-	fin-	fin-	fin-		fin-	fin-	fin-	fin-	fin-
R/W	:	—	—	—	—	—	---	—	—	—	—	—

SAR is a 24-bit register that designates the source address of data to be transferred by the DTC. For word-size transfer, specify an even source address.

## 8.2.4 DTC Destination Address Register (DAR)

Bit	:	23	22	21	20	19	---					4	3	2	1	0
Initial value	:	Unde-	Unde-	Unde-	Unde-	Unde-	---					Unde-	Unde-	Unde-	Unde-	Unde-
		fin-	fin-	fin-	fin-	fin-						fin-	fin-	fin-	fin-	fin-
R/W	:	—	—	—	—	—	---					—	—	—	—	—

DAR is a 24-bit register that designates the destination address of data to be transferred by the DTC. For word-size transfer, specify an even destination address.

## 8.2.5 DTC Transfer Count Register A (CRA)

Bit	:	15	14	13	12	11	10	9	8	7	6	5	4	3	2	1	0
Initial value:		Unde-	Unde-	Unde-	Unde-	Unde-	Unde-	Unde-	Unde-	Unde-	Unde-	Unde-	Unde-	Unde-	Unde-	Unde-	Unde-
		fin-	fin-	fin-	fin-	fin-	fin-	fin-	fin-	fin-	fin-	fin-	fin-	fin-	fin-	fin-	fin-
R/W	:	—	—	—	—	—	—	—	—	—	—	—	—	—	—	—	—

CRAH
 

 CRAL

CRA is a 16-bit register that designates the number of times data is to be transferred by the DTC.

In normal mode, the entire CRA functions as a 16-bit transfer counter (1 to 65536). It is decremented by 1 every time data is transferred, and transfer ends when the count reaches H'0000.

In repeat mode or block transfer mode, the CRA is divided into two parts: the upper 8 bits (CRAH) and the lower 8 bits (CRAL). CRAH holds the number of transfers while CRAL functions as an 8-bit transfer counter (1 to 256). CRAL is decremented by 1 every time data is transferred, and the contents of CRAH are sent when the count reaches H'00. This operation is repeated.

## 8.2.6 DTC Transfer Count Register B (CRB)

Bit	:	15	14	13	12	11	10	9	8	7	6	5	4	3	2	1	0
Initial value:		Unde-	Unde-	Unde-	Unde-	Unde-	Unde-	Unde-	Unde-	Unde-	Unde-	Unde-	Unde-	Unde-	Unde-	Unde-	Unde-
		fin-	fin-	fin-	fin-	fin-	fin-	fin-	fin-	fin-	fin-	fin-	fin-	fin-	fin-	fin-	fin-
R/W	:	—	—	—	—	—	—	—	—	—	—	—	—	—	—	—	—

CRB is a 16-bit register that designates the number of times data is to be transferred by the DTC in block transfer mode. It functions as a 16-bit transfer counter (1 to 65536) that is decremented by 1 every time data is transferred, and transfer ends when the count reaches H'0000.

## 8.2.7 DTC Enable Registers (DTCER)

Bit	:	7	6	5	4	3	2	1	0
		DTCE7	DTCE6	DTCE5	DTCE4	DTCE3	DTCE2	DTCE1	DTCE0
Initial value:		0	0	0	0	0	0	0	0
R/W	:	R/W	R/W	R/W	R/W	R/W	R/W	R/W	R/W

The DTC enable registers comprise six 8-bit readable/writable registers, DTCERA to DTCERE and DTCERI, with bits corresponding to the interrupt sources that can control enabling and disabling of DTC activation. These bits enable or disable DTC service for the corresponding interrupt sources.

The DTC enable registers are initialized to H'00 by a reset and in hardware standby mode.

### Bit n—DTC Activation Enable (DTCEn)

Bit n

DTCEn	Description
0	DTC activation by this interrupt is disabled (Initial value) [Clearing conditions] <ul style="list-style-type: none"> <li>• When the DISEL bit is 1 and the data transfer has ended</li> <li>• When the specified number of transfers have ended</li> </ul>
1	DTC activation by this interrupt is enabled [Holding condition] When the DISEL bit is 0 and the specified number of transfers have not ended

(n = 7 to 0)

A DTCE bit can be set for each interrupt source that can activate the DTC. The correspondence between interrupt sources and DTCE bits is shown in table 8.4, together with the vector number generated for each interrupt controller.

For DTCE bit setting, use bit manipulation instructions such as BSET and BCLR for reading and writing. If all interrupts are masked, multiple activation sources can be set at one time by writing data after executing a dummy read on the relevant register.



## 8.2.8 DTC Vector Register (DTVECR)

Bit	:	7	6	5	4	3	2	1	0
		SWDTE	DTVEC6	DTVEC5	DTVEC4	DTVEC3	DTVEC2	DTVEC1	DTVEC0
Initial value:		0	0	0	0	0	0	0	0
R/W	:	R/(W)*1	R/(W)*2	R/(W)*2	R/(W)*2	R/(W)*2	R/(W)*2	R/(W)*2	R/(W)*2

Notes: \*1 Only 1 can be written to the SWDTE bit.

\*2 Bits DTVEC6 to DTVEC0 can be written to when SWDTE = 0.

DTVECR is an 8-bit readable/writable register that enables or disables DTC activation by software, and sets a vector number for the software activation interrupt.

DTVECR is initialized to H'00 by a reset and in hardware standby mode.

**Bit 7—DTC Software Activation Enable (SWDTE):** Enables or disables DTC activation by software.

### Bit 7

SWDTE	Description
0	DTC software activation is disabled (Initial value) [Clearing conditions] <ul style="list-style-type: none"> <li>When the DISEL bit is 0 and the specified number of transfers have not ended</li> <li>When 0 is written to the DISEL bit after a software-activated data transfer end interrupt (SWDTEND) request has been sent to the CPU</li> </ul>
1	DTC software activation is enabled [Holding conditions] <ul style="list-style-type: none"> <li>When the DISEL bit is 1 and data transfer has ended</li> <li>When the specified number of transfers have ended</li> <li>During data transfer due to software activation</li> </ul>

**Bits 6 to 0—DTC Software Activation Vectors 6 to 0 (DTVEC6 to DTVEC0):** These bits specify a vector number for DTC software activation.

The vector address is expressed as H'0400 + ((vector number) << 1). <<1 indicates a one-bit left-shift. For example, when DTVEC6 to DTVEC0 = H'10, the vector address is H'0420.

## 8.2.9 Module Stop Control Register A (MSTPCRA)

Bit	:	7	6	5	4	3	2	1	0
		MSTPA7	MSTPA6	MSTPA5	MSTPA4	MSTPA3	MSTPA2	MSTPA1	MSTPA0
Initial value	:	0	0	1	1	1	1	1	1
R/W	:	R/W	R/W	R/W	R/W	R/W	R/W	R/W	R/W

MSTPCRA is an 8-bit readable/writable register that performs module stop mode control.

When the MSTPA6 bit in MSTPCRA is set to 1, the DTC operation stops at the end of the bus cycle and a transition is made to module stop mode. However, 1 cannot be written in the MSTPA6 bit while the DTC is operating. For details, see section 19.5, Module Stop Mode.

MSTPCRA is initialized to H'3F by a reset and in hardware standby mode. It is not initialized in software standby mode.

**Bit 6—Module Stop (MSTPA6):** Specifies the DTC module stop mode.

### Bit 6

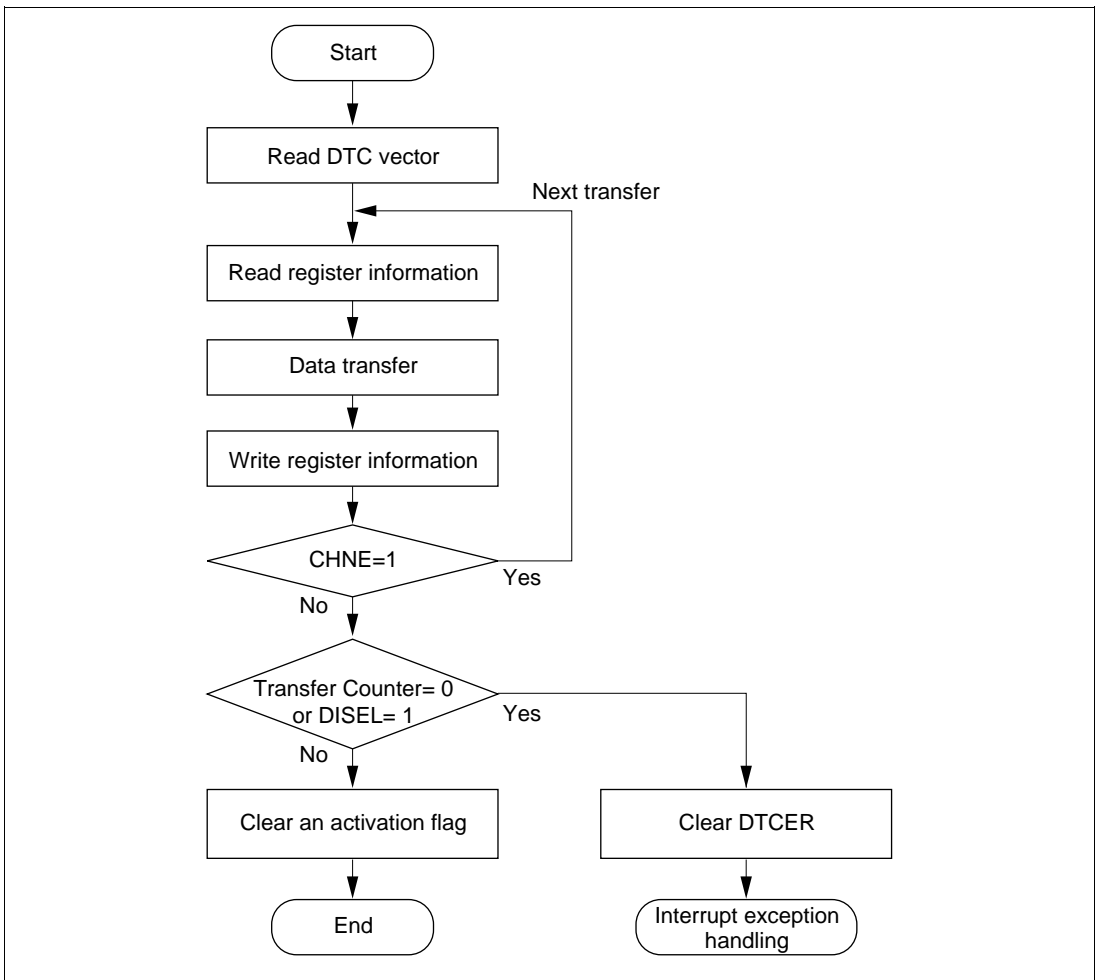
MSTPA6	Description
0	DTC module stop mode cleared (Initial value)
1	DTC module stop mode set

## 8.3 Operation

### 8.3.1 Overview

When activated, the DTC reads register information that is already stored in memory and transfers data on the basis of that register information. After the data transfer, it writes updated register information back to memory. Pre-storage of register information in memory makes it possible to transfer data over any required number of channels. Setting the CHNE bit to 1 makes it possible to perform a number of transfers with a single activation.

Figure 8.2 shows a flowchart of DTC operation.



**Figure 8.2 Flowchart of DTC Operation**

The DTC transfer mode can be normal mode, repeat mode, or block transfer mode.

The 24-bit SAR designates the DTC transfer source address and the 24-bit DAR designates the transfer destination address. After each transfer, SAR and DAR are independently incremented, decremented, or left fixed.

Table 8.2 outlines the functions of the DTC.

**Table 8.2 DTC Functions**

Transfer Mode	Activation Source	Address Registers	
		Transfer Source	Transfer Destination
<ul style="list-style-type: none"> <li>• Normal mode               <ul style="list-style-type: none"> <li>— One transfer request transfers one byte or one word</li> <li>— Memory addresses are incremented or decremented by 1 or 2</li> <li>— Up to 65,536 transfers possible</li> </ul> </li> <li>• Repeat mode               <ul style="list-style-type: none"> <li>— One transfer request transfers one byte or one word</li> <li>— Memory addresses are incremented or decremented by 1 or 2</li> <li>— After the specified number of transfers (1 to 256), the initial state resumes and operation continues</li> </ul> </li> <li>• Block transfer mode               <ul style="list-style-type: none"> <li>— One transfer request transfers a block of the specified size</li> <li>— Block size is from 1 to 256 bytes or words</li> <li>— Up to 65,536 transfers possible</li> <li>— A block area can be designated at either the source or destination</li> </ul> </li> </ul>	<ul style="list-style-type: none"> <li>• IRQ</li> <li>• TPU TGI</li> <li>• 8-bit timer CMI</li> <li>• SCI TXI or RXI</li> <li>• A/D converter ADI</li> <li>• Software</li> </ul>	24 bits	24 bits

### 8.3.2 Activation Sources

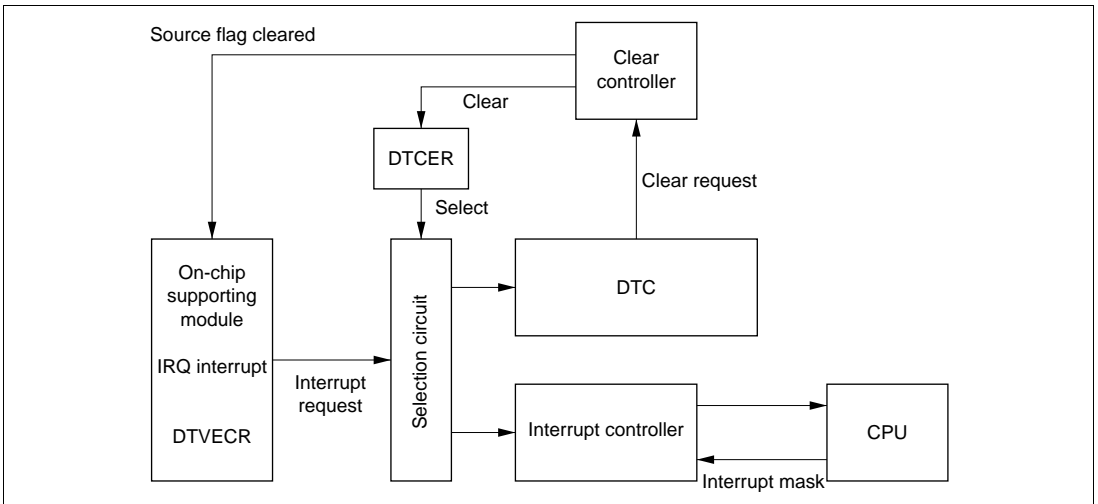
The DTC operates when activated by an interrupt or by a write to DTVECR by software. An interrupt request can be directed to the CPU or DTC, as designated by the corresponding DTCER bit. An interrupt becomes a DTC activation source when the corresponding bit is set to 1, and a CPU interrupt source when the bit is cleared to 0.

At the end of a data transfer (or the last consecutive transfer in the case of chain transfer), the activation source or corresponding DTCER bit is cleared. Table 8.3 shows activation source and DTCER clearance. The activation source flag, in the case of RXI0, for example, is the RDRF flag of SCIO.

**Table 8.3 Activation Source and DTCER Clearance**

Activation Source	When the DIESEL Bit Is 0 and the Specified Number of Transfers Have Not Ended	When the DIESEL Bit Is 1, or when the Specified Number of Transfers Have Ended
Software activation	The SWDTE bit is cleared to 0	The SWDTE bit remains set to 1 An interrupt is issued to the CPU
Interrupt activation	The corresponding DTCER bit remains set to 1  The activation source flag is cleared to 0	The corresponding DTCER bit is cleared to 0  The activation source flag remains set to 1 A request is issued to the CPU for the activation source interrupt

Figure 8.3 shows a block diagram of activation source control. For details see section 5, Interrupt Controller.



**Figure 8.3 Block Diagram of DTC Activation Source Control**

When an interrupt has been designated a DTC activation source, existing CPU mask level and interrupt controller priorities have no effect. If there is more than one activation source at the same time, the DTC operates in accordance with the default priorities.

### 8.3.3 DTC Vector Table

Figure 8.4 shows the correspondence between DTC vector addresses and register information.

Table 8.4 shows the correspondence between activation and vector addresses. When the DTC is activated by software, the vector address is obtained from:  $H'0400 + (DTVECR[6:0] \ll 1)$  (where  $\ll 1$  indicates a 1-bit left shift). For example, if DTVECR is H'10, the vector address is H'0420.

The DTC reads the start address of the register information from the vector address set for each activation source, and then reads the register information from that start address. The register information can be placed at predetermined addresses in the on-chip RAM. The start address of the register information should be an integral multiple of four.

The configuration of the vector address is the same in both normal\* and advanced modes, a 2-byte unit being used in both cases. These two bytes specify the lower bits of the address in the on-chip RAM.

Note: \* Not available in the LSI.

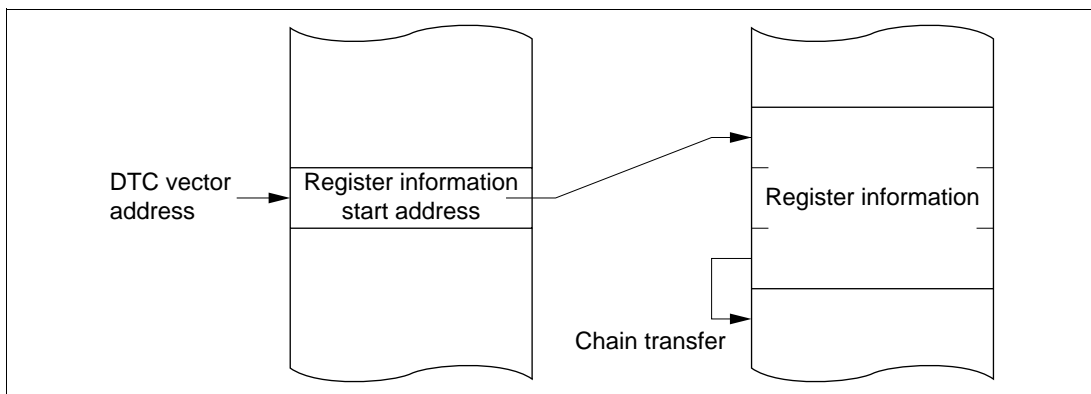
**Table 8.4 Interrupt Sources, DTC Vector Addresses, and Corresponding DTCEs**

Interrupt Source	Origin of Interrupt Source	Vector Number	Vector Address	DTCE* <sup>1</sup>	Priority
Write to DTVECR	Software	DTVECR	H'0400+ (DTVECR [6:0] <<1)	—	High
IRQ0	External pin	16	H'0420	DTCEA7	↑
IRQ1		17	H'0422	DTCEA6	
IRQ2		18	H'0424	DTCEA5	
IRQ3		19	H'0426	DTCEA4	
IRQ4		20	H'0428	DTCEA3	
IRQ5		21	H'042A	DTCEA2	
IRQ6* <sup>2</sup>		22	H'042C	DTCEA1	
IRQ7		23	H'042E	DTCEA0	
ADI (A/D conversion end)	A/D	28	H'0438	DTCEB6	
TGI0A (GR0A compare match/ input capture)	TPU channel 0	32	H'0440	DTCEB5	
TGI0B (GR0B compare match/ input capture)		33	H'0442	DTCEB4	
TGI0C (GR0C compare match/ input capture)		34	H'0444	DTCEB3	
TGI0D (GR0D compare match/ input capture)		35	H'0446	DTCEB2	
TGI1A (GR1A compare match/ input capture)		TPU channel 1	40	H'0450	DTCEB1
TGI1B (GR1B compare match)	41		H'0452	DTCEB0	
TGI2A (GR2A compare match/ input capture)	TPU channel 2	44	H'0458	DTCEC7	
TGI2B (GR2B compare match)		45	H'045A	DTCEC6	
CMIA0 (compare match A)	8-bit timer channel 0	64	H'0480	DTCED3	
CMIB0 (compare match B)		65	H'0482	DTCED2	
CMIA1 (compare match A)	8-bit timer channel 1	68	H'0488	DTCED1	
CMIB1 (compare match B)		69	H'048A	DTCED0	Low

Interrupt Source	Origin of Interrupt Source	Vector Number	Vector Address	DTCE* <sup>1</sup>	Priority
RXI0 (reception complete 0)	SCI	81	H'04A2	DTCEE3	↑ High
TXI0 (transmit data empty 0)	channel 0	82	H'04A4	DTCEE2	
RXI1 (reception complete 1)	SCI	85	H'04AA	DTCEE1	
TXI1 (transmit data empty 1)	channel 1	86	H'04AC	DTCEE0	
RXI3 (reception complete 3)	SCI	121	H'04F2	DTCEI7	
TXI3 (transmit data empty 3)	channel 3	122	H'04F4	DTCEI6	

Notes: \*1 DTCE bits with no corresponding interrupt are reserved, and should be written with 0.

\*2 IRQ6 is a dedicated interrupt source for the FLEX™ decoder II.



**Figure 8.4 Correspondence between DTC Vector Address and Register Information**

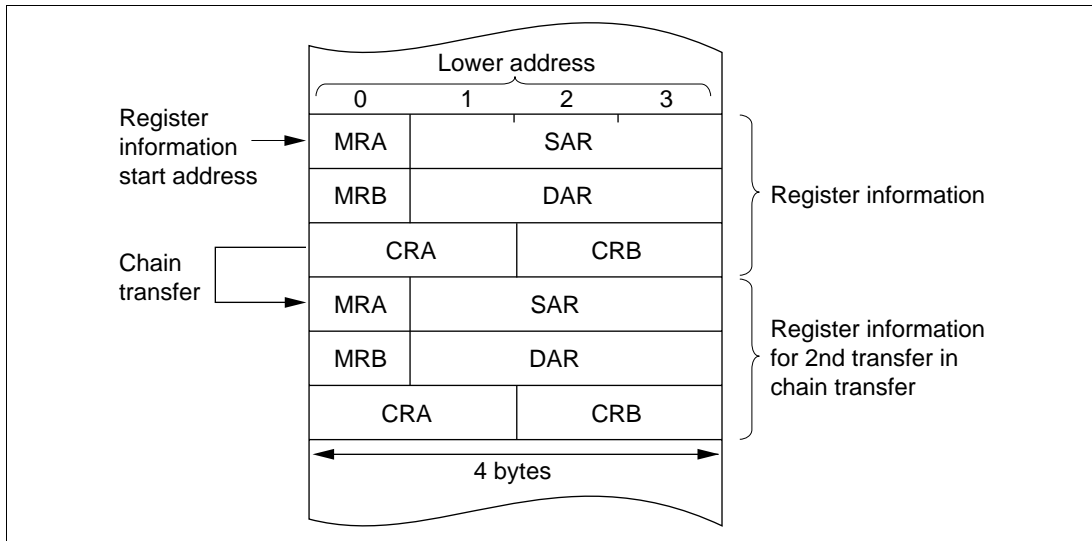


### 8.3.4 Location of Register Information in Address Space

Figure 8.5 shows how the register information should be located in the address space.

Locate the MRA, SAR, MRB, DAR, CRA, and CRB registers, in that order, from the start address of the register information (contents of the vector address). In the case of chain transfer, register information should be located in consecutive areas.

Locate the register information in the on-chip RAM (addresses: H'FFEBC0 to H'FFEFBF).



**Figure 8.5 Location of Register Information in Address Space**

### 8.3.5 Normal Mode

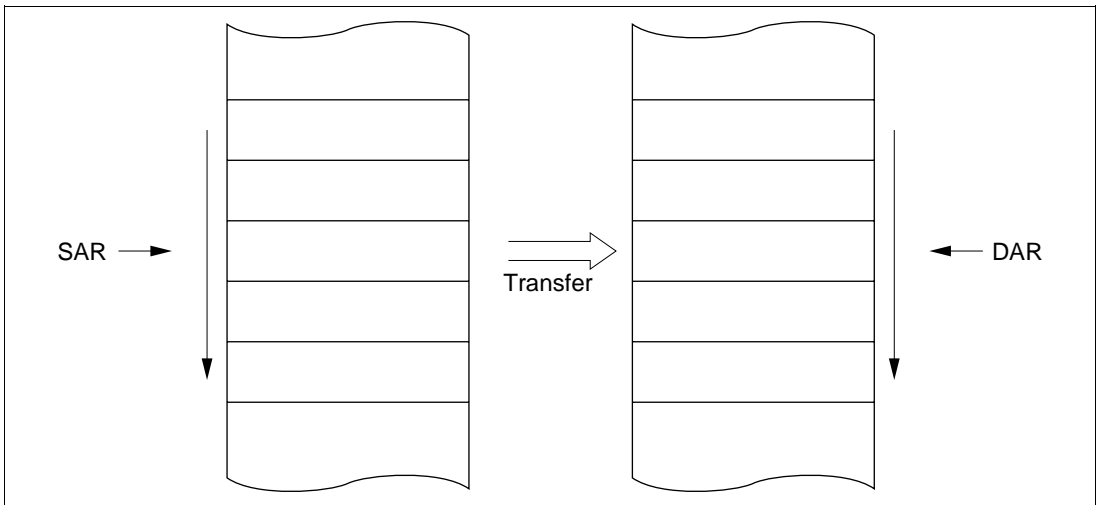
In normal mode, one operation transfers one byte or one word of data.

From 1 to 65,536 transfers can be specified. Once the specified number of transfers have ended, a CPU interrupt can be requested.

Table 8.5 lists the register information in normal mode and figure 8.6 shows memory mapping in normal mode.

**Table 8.5 Register Information in Normal Mode**

Name	Abbreviation	Function
DTC source address register	SAR	Designates source address
DTC destination address register	DAR	Designates destination address
DTC transfer count register A	CRA	Designates transfer count
DTC transfer count register B	CRB	Not used



**Figure 8.6 Memory Mapping in Normal Mode**

### 8.3.6 Repeat Mode

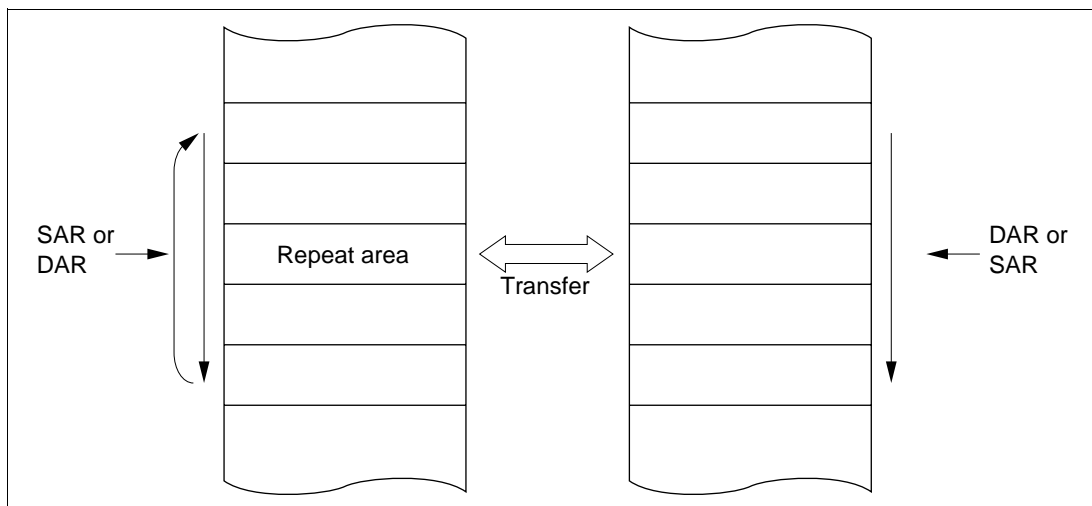
In repeat mode, one operation transfers one byte or one word of data.

From 1 to 256 transfers can be specified. Once the specified number of transfers have ended, the initial state of the transfer counter and the address register specified as the repeat area is restored, and transfer is repeated. In repeat mode the transfer counter value does not reach H'00, and therefore CPU interrupts cannot be requested when  $DISEL = 0$ .

Table 8.6 lists the register information in repeat mode and figure 8.7 shows memory mapping in repeat mode.

**Table 8.6 Register Information in Repeat Mode**

Name	Abbreviation	Function
DTC source address register	SAR	Designates source address
DTC destination address register	DAR	Designates destination address
DTC transfer count register AH	CRAH	Holds number of transfers
DTC transfer count register AL	CRAL	Designates transfer count
DTC transfer count register B	CRB	Not used



**Figure 8.7 Memory Mapping in Repeat Mode**

### 8.3.7 Block Transfer Mode

In block transfer mode, one operation transfers one block of data. Either the transfer source or the transfer destination is designated as a block area.

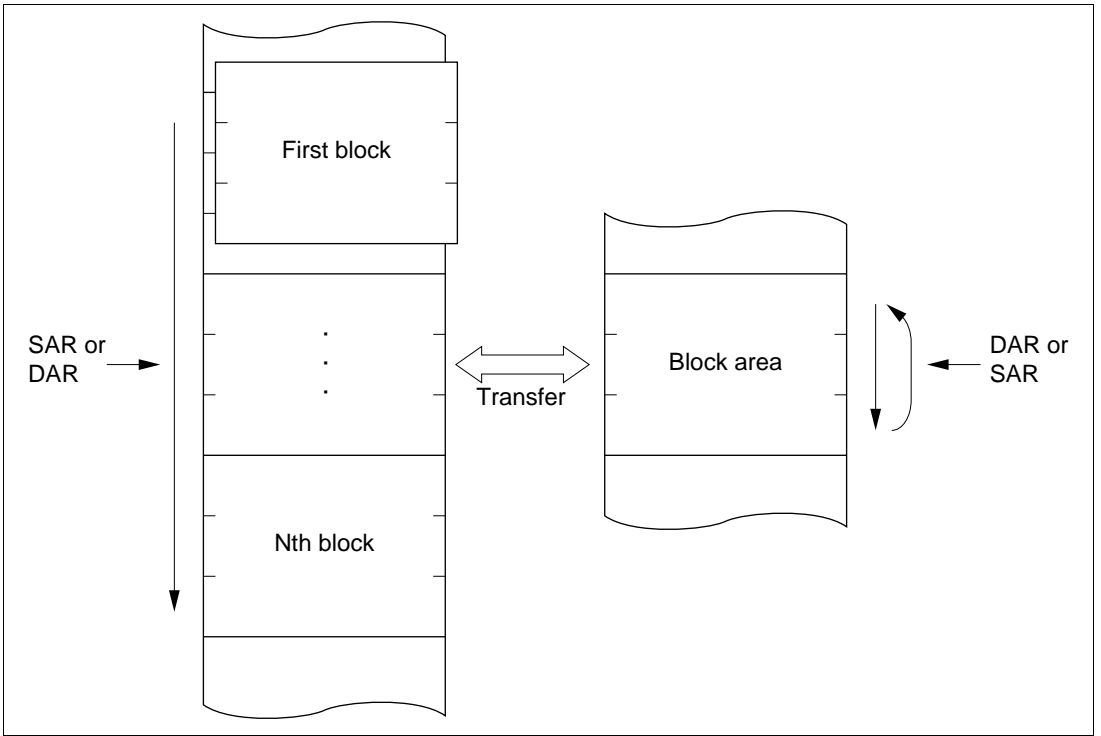
The block size is 1 to 256. When the transfer of one block ends, the initial state of the block size counter and the address register specified as the block area is restored. The other address register is then incremented, decremented, or left fixed.

From 1 to 65,536 transfers can be specified. Once the specified number of transfers have ended, a CPU interrupt is requested.

Table 8.7 lists the register information in block transfer mode and figure 8.8 shows memory mapping in block transfer mode.

**Table 8.7 Register Information in Block Transfer Mode**

<b>Name</b>	<b>Abbreviation</b>	<b>Function</b>
DTC source address register	SAR	Designates source address
DTC destination address register	DAR	Designates destination address
DTC transfer count register AH	CRAH	Holds block size
DTC transfer count register AL	CRAL	Designates block size count
DTC transfer count register B	CRB	Transfer count

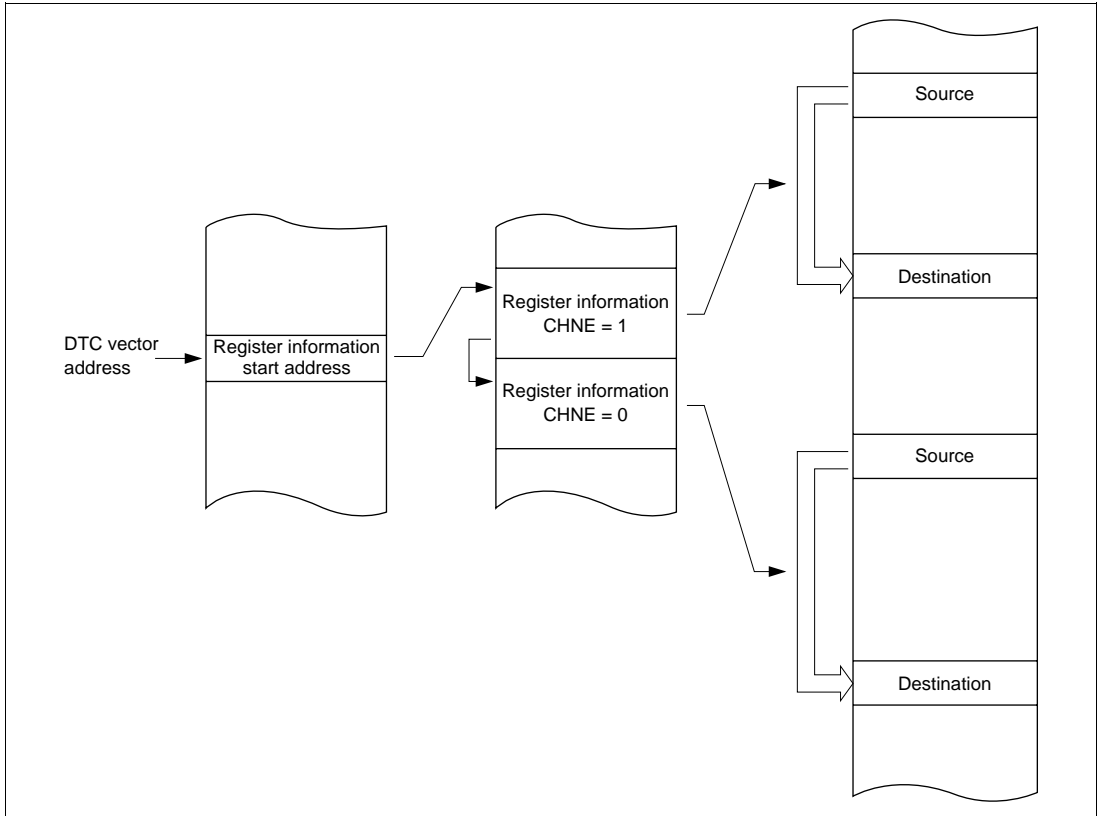


**Figure 8.8 Memory Mapping in Block Transfer Mode**

### 8.3.8 Chain Transfer

Setting the CHNE bit to 1 enables a number of data transfers to be performed consecutively in response to a single transfer request. SAR, DAR, CRA, CRB, MRA, and MRB, which define data transfers, can be set independently.

Figure 8.9 shows the memory map for chain transfer.

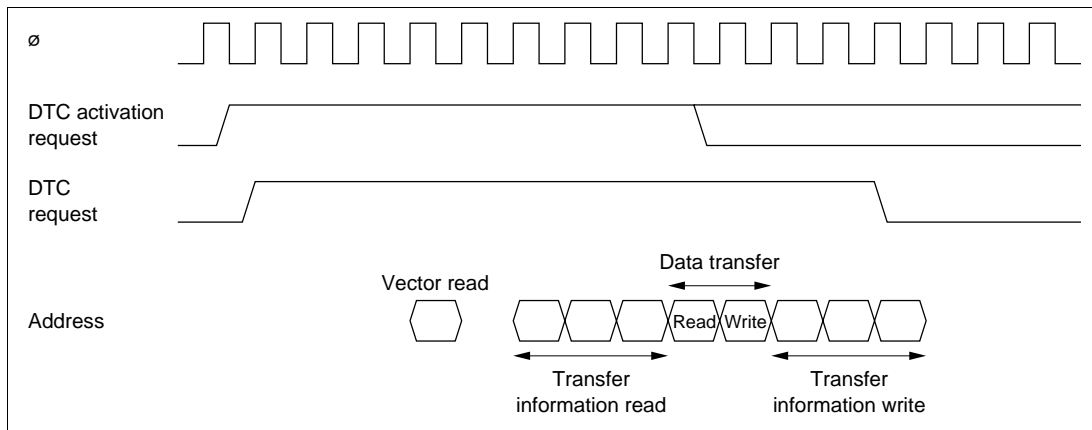


**Figure 8.9 Chain Transfer Memory Map**

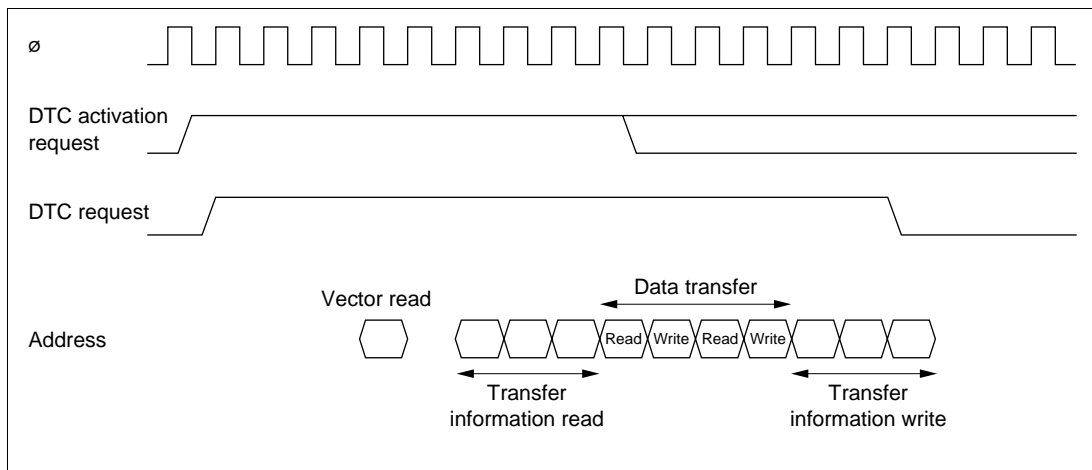
In the case of transfer with CHNE set to 1, an interrupt request to the CPU is not generated at the end of the specified number of transfers or by setting of the DISSEL bit to 1, and the interrupt source flag for the activation source is not affected.

### 8.3.9 Operation Timing

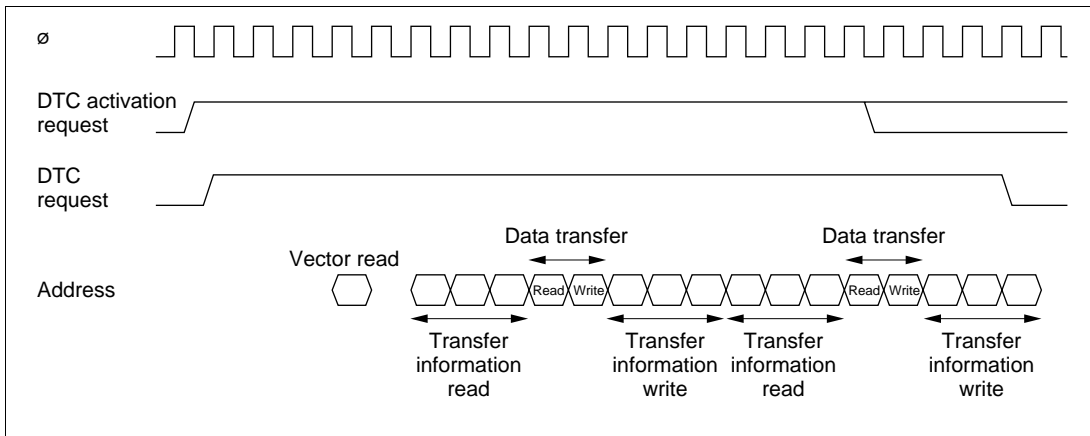
Figures 8.10 to 8.12 show an example of DTC operation timing.



**Figure 8.10 DTC Operation Timing (Example in Normal Mode or Repeat Mode)**



**Figure 8.11 DTC Operation Timing (Example of Block Transfer Mode, with Block Size of 2)**



**Figure 8.12 DTC Operation Timing (Example of Chain Transfer)**

### 8.3.10 Number of DTC Execution States

Table 8.8 lists execution statuses for a single DTC data transfer, and table 8.9 shows the number of states required for each execution status.

**Table 8.8 DTC Execution Statuses**

Mode	Register Information				
	Vector Read I	Read/Write J	Data Read K	Data Write L	Internal Operations M
Normal	1	6	1	1	3
Repeat	1	6	1	1	3
Block transfer	1	6	N	N	3

N: Block size (initial setting of CRAH and CRAL)



**Table 8.9 Number of States Required for Each Execution Status**

Object to be Accessed		On-Chip RAM	On-Chip ROM	On-Chip I/O Registers		External Devices				
Bus width		32	16	8	16	8	8	16	16	
Access states		1	1	2	2	2	3	2	3	
Execution status	Vector read	$S_I$	—	1	—	—	4	6+2m	2	3+m
	Register information read/write	$S_J$	1	—	—	—	—	—	—	—
	Byte data read	$S_K$	1	1	2	2	2	3+m	2	3+m
	Word data read	$S_K$	1	1	4	2	4	6+2m	2	3+m
	Byte data write	$S_L$	1	1	2	2	2	3+m	2	3+m
	Word data write	$S_L$	1	1	4	2	4	6+2m	2	3+m
	Internal operation	$S_M$	1	1	1	1	1	1	1	1

m: Number of wait states in external device access

The number of execution states is calculated from the formula below. Note that  $\Sigma$  means the sum of all transfers activated by one activation event (the number in which the CHNE bit is set to 1, plus 1).

$$\text{Number of execution states} = I \cdot S_I + \Sigma (J \cdot S_J + K \cdot S_K + L \cdot S_L) + M \cdot S_M$$

For example, when the DTC vector address table is located in on-chip ROM, normal mode is set, and data is transferred from the on-chip ROM to an internal I/O register, the time required for the DTC operation is 13 states. The time from activation to the end of the data write is 10 states.

### 8.3.11 Procedures for Using DTC

**Activation by Interrupt:** The procedure for using the DTC with interrupt activation is as follows:

- [1] Set the MRA, MRB, SAR, DAR, CRA, and CRB register information in the on-chip RAM.
- [2] Set the start address of the register information in the DTC vector address.
- [3] Set the corresponding bit in DTCER to 1.
- [4] Set the enable bits for the interrupt sources to be used as the activation sources to 1. The DTC is activated when an interrupt used as an activation source is generated.

- [5] After the end of one data transfer, or after the specified number of data transfers have ended, the DTCE bit is cleared to 0 and a CPU interrupt is requested. If the DTC is to continue transferring data, set the DTCE bit to 1.

**Activation by Software:** The procedure for using the DTC with software activation is as follows:

- [1] Set the MRA, MRB, SAR, DAR, CRA, and CRB register information in the on-chip RAM.
- [2] Set the start address of the register information in the DTC vector address.
- [3] Check that the SWDTE bit is 0.
- [4] Write 1 to SWDTE bit and the vector number to DTVECR.
- [5] Check the vector number written to DTVECR.
- [6] After the end of one data transfer, if the DISEL bit is 0 and a CPU interrupt is not requested, the SWDTE bit is cleared to 0. If the DTC is to continue transferring data, set the SWDTE bit to 1. When the DISEL bit is 1, or after the specified number of data transfers have ended, the SWDTE bit is held at 1 and a CPU interrupt is requested.

### 8.3.12 Examples of Use of the DTC

#### (1) Normal Mode

An example is shown in which the DTC is used to receive 128 bytes of data via the SCI.

- [1] Set MRA to fixed source address ( $SM1 = SM0 = 0$ ), incrementing destination address ( $DM1 = 1, DM0 = 0$ ), normal mode ( $MD1 = MD0 = 0$ ), and byte size ( $Sz = 0$ ). The DTS bit can have any value. Set MRB for one data transfer by one interrupt ( $CHNE = 0, DISEL = 0$ ). Set the SCI RDR address in SAR, the start address of the RAM area where the data will be received in DAR, and 128 (H'0080) in CRA. CRB can be set to any value.
- [2] Set the start address of the register information at the DTC vector address.
- [3] Set the corresponding bit in DTCER to 1.
- [4] Set the SCI to the appropriate receive mode. Set the RIE bit in SCR to 1 to enable the reception complete (RXI) interrupt. Since the generation of a receive error during the SCI reception operation will disable subsequent reception, the CPU should be enabled to accept receive error interrupts.
- [5] Each time reception of one byte of data ends on the SCI, the RDRF flag in SSR is set to 1, an RXI interrupt is generated, and the DTC is activated. The receive data is transferred from RDR to RAM by the DTC. DAR is incremented and CRA is decremented. The RDRF flag is automatically cleared to 0.

[6] When CRA becomes 0 after the 128 data transfers have ended, the RDRF flag is held at 1, the DTCE bit is cleared to 0, and an RXI interrupt request is sent to the CPU. The interrupt handling routine should perform wrap-up processing.

## (2) Software Activation

An example is shown in which the DTC is used to transfer a block of 128 bytes of data by means of software activation. The transfer source address is H'1000 and the destination address is H'2000. The vector number is H'60, so the vector address is H'04C0.

- [1] Set MRA to incrementing source address (SM1 = 1, SM0 = 0), incrementing destination address (DM1 = 1, DM0 = 0), block transfer mode (MD1 = 1, MD0 = 0), and byte size (Sz = 0). The DTS bit can have any value. Set MRB for one block transfer by one interrupt (CHNE = 0). Set the transfer source address (H'1000) in SAR, the destination address (H'2000) in DAR, and 128 (H'8080) in CRA. Set 1 (H'0001) in CRB.
- [2] Set the start address of the register information at the DTC vector address (H'04C0).
- [3] Check that the SWDTE bit in DTVECR is 0. Check that there is currently no transfer activated by software.
- [4] Write 1 to the SWDTE bit and the vector number (H'60) to DTVECR. The write data is H'E0.
- [5] Read DTVECR again and check that it is set to the vector number (H'60). If it is not, this indicates that the write failed. This is presumably because an interrupt occurred between steps 3 and 4 and led to a different software activation. To activate this transfer, go back to step 3.
- [6] If the write was successful, the DTC is activated and a block of 128 bytes of data is transferred.
- [7] After the transfer, an SWDTEND interrupt occurs. The interrupt handling routine should clear the SWDTE bit to 0 and perform other wrap-up processing.

## 8.4 Interrupts

An interrupt request is issued to the CPU when the DTC finishes the specified number of data transfers, or a data transfer for which the DISEL bit was set to 1. In the case of interrupt activation, the interrupt set as the activation source is generated. These interrupts to the CPU are subject to CPU mask level and interrupt controller priority level control.

In the case of activation by software, a software activated data transfer end interrupt (SWDTEND) is generated.

When the DISEL bit is 1 and one data transfer has ended, or the specified number of transfers have ended, after data transfer ends, the SWDTE bit is held at 1 and an SWDTEND interrupt is generated. The interrupt handling routine should clear the SWDTE bit to 0.

When the DTC is activated by software, an SWDTEND interrupt is not generated during a data transfer wait or during data transfer even if the SWDTE bit is set to 1.

## 8.5 Usage Notes

**Module Stop:** DTC operation can be disabled or enabled using the module stop control register. The initial setting is for DTC operation to be enabled. Register access is disabled by setting module stop mode. Module stop mode cannot be set during DTC operation. For details, refer to section 19, Power-Down Modes.

**On-Chip RAM:** The MRA, MRB, SAR, DAR, CRA, and CRB registers are all located in on-chip RAM. When the DTC is used, the RAME bit in SYSCR must not be cleared to 0.

**DTCE Bit Setting:** For DTCE bit setting, use bit manipulation instructions such as BSET and BCLR. If all interrupts are masked, multiple activation sources can be set at one time by writing data after executing a dummy read on the relevant register.

# Section 9 I/O Ports

## 9.1 Overview

The LSI has nine I/O ports (ports 1, 3, and A to G), and one input-only port (port 4). Also it has one internal 4-bit I/O port (port 7), one internal 1-bit I/O port (port 36), and one input-only port (port G0) for the FLEX™ decoder II interface.

Table 9.1 summarizes the port functions. The pins of each port also have other functions.

Each port includes a data direction register (DDR) that controls input/output (not provided for the input-only ports), a data register (DR) that stores output data, and a port register (PORT) used to read the pin states.

Ports A to E have a built-in MOS input pull-up function, and in addition to DR and DDR, have a MOS input pull-up control register (PCR) to control the on/off status of the MOS input pull-ups.

Ports 3 and A include an open-drain control register (ODR) that controls the on/off status of the output buffer PMOS.

All the ports can drive a single TTL load and 30 pF capacitive load.

The  $\overline{\text{IRQ}}$  pins are Schmitt-triggered inputs.

Block diagrams of each port are give in Appendix C, I/O Port Block Diagrams.

**Table 9.1 H8S/2276 Series Port Functions**

Port	Description	Pins	Mode 4	Mode 5	Mode 6	Mode 7
Port 1	<ul style="list-style-type: none"> <li>6-bit I/O port</li> <li>Schmitt-triggered input (<math>\overline{\text{IRQ0}}</math>, <math>\overline{\text{IRQ1}}</math>)</li> </ul>	P16/TIOCA2/ $\overline{\text{IRQ1}}$ P14/TIOCA1/ $\overline{\text{IRQ0}}$ P13/TIOCD0/TCLKB/A23 P12/TIOCC0/TCLKA/A22 P11/TIOCB0/A21 P10/TIOCA0/A20	6-bit I/O port also functioning as TPU I/O pins (TCLKA, TCLKB, TIOCA0, TIOCB0, TIOCC0, TIOCD0, TIOCA1, TIOCA2), interrupt input pins ( $\overline{\text{IRQ0}}$ , $\overline{\text{IRQ1}}$ ), and address output (A20 to A23)			6-bit I/O port also functioning as TPU I/O pins (TCLKA, TCLKB, TIOCA0, TIOCB0, TIOCC0, TIOCD0, TIOCA1, TIOCA2) and interrupt input pins ( $\overline{\text{IRQ0}}$ , $\overline{\text{IRQ1}}$ )
Port 3	<ul style="list-style-type: none"> <li>6-bit I/O port</li> <li>Open-drain output capability</li> <li>Schmitt-triggered input (<math>\overline{\text{IRQ4}}</math>, <math>\overline{\text{IRQ5}}</math>)</li> </ul>	P35/SCK1/ $\overline{\text{IRQ5}}$ P34/RxD1 P33/TxD1 P32/SCK0/ $\overline{\text{IRQ4}}$ P31/RxD0 P30/TxD0	6-bit I/O port also functioning as SCI (channel 0 and 1) I/O pins (TxD0, RxD0, SCK0, TxD1, RxD1, SCK1) and interrupt input pins ( $\overline{\text{IRQ4}}$ , $\overline{\text{IRQ5}}$ )			1-bit I/O port
	<ul style="list-style-type: none"> <li>1-bit I/O port (dedicated internal I/O port for the FLEX™ decoder II interface)</li> </ul>	P36				
Port 4	<ul style="list-style-type: none"> <li>8-bit input port</li> </ul>	P47/AN7 P46/AN6 P45/AN5 P44/AN4 P43/AN3 P42/AN2 P41/AN1 P40/AN0	8-bit input port also functioning as A/D converter analog input (AN7 to AN0)			
Port 7	<ul style="list-style-type: none"> <li>4-bit I/O port (dedicated I/O port for the FLEX™ decoder II interface)</li> </ul>	P77/TxD3 P76/RxD3 P75/SCK3 P74	4-bit I/O port also functioning as SCI (channel 3) I/O pins (TxD3, RxD3, SCK3)			
Port A	<ul style="list-style-type: none"> <li>4-bit I/O port</li> <li>Built-in MOS input pull-up</li> <li>Open-drain output capability</li> </ul>	PA3/A19 to PA0/A16	4-bit I/O port also functioning as address output (A19 to A16)		4-bit I/O port	
Port B	<ul style="list-style-type: none"> <li>8-bit I/O port</li> <li>Built-in MOS input pull-up</li> </ul>	PB7/A15 to PB0/A8	8-bit I/O port also functioning as address output (A15 to A8)		8-bit I/O port	
Port C	<ul style="list-style-type: none"> <li>8-bit I/O port</li> <li>Built-in MOS input pull-up</li> </ul>	PC7/A7 to PC0/A0	Address output (A7 to A0)		When DDR = 0: Input port When DDR = 1: Address output	8-bit I/O port
Port D	<ul style="list-style-type: none"> <li>8-bit I/O port</li> <li>Built-in MOS input pull-up</li> </ul>	PD7/D15 to PD0/D8	Data bus input/output (D15 to D8)		8-bit I/O port	

Port	Description	Pins	Mode 4	Mode 5	Mode 6	Mode 7
Port E	<ul style="list-style-type: none"> <li>8-bit I/O port</li> <li>Built-in MOS input pull-up</li> </ul>	PE7/D7 to PE0/D0	In 8-bit bus mode: 8-bit I/O port In 16-bit bus mode: Data bus input/output (D7 to D0)			8-bit I/O port
Port F	<ul style="list-style-type: none"> <li>8-bit I/O port</li> <li>Schmitt-triggered input (IRQ3, IRQ2)</li> </ul>	PF7/ $\emptyset$	When DDR = 0: Input port When DDR = 1 (after reset): $\emptyset$ output			When DDR = 0 (after reset): Input port When DDR = 1: $\emptyset$ output
		PF6/ $\overline{AS}$ PF5/ $\overline{RD}$ PF4/ $\overline{HWR}$	AS, RD, HWR output			3-bit I/O port
		PF3/ $\overline{LWR}$ / $\overline{ADTRG}$ / $\overline{IRQ3}$	In 16-bit bus mode: $\overline{LWR}$ output In 8-bit bus mode: I/O port also functioning as interrupt input pin ( $\overline{IRQ3}$ ) and A/D converter input ( $\overline{ADTRG}$ )			I/O port also functioning as interrupt input pin ( $\overline{IRQ3}$ ) and A/D converter input ( $\overline{ADTRG}$ )
		PF2/ $\overline{WAITE}$	When WAITE = 0 (after reset): I/O port When WAITE = 1: WAIT input			I/O port
		PF1/ $\overline{BACK}$ / $\overline{BUZZ}$ PF0/ $\overline{BREQ}$ / $\overline{IRQ2}$	When BRLE = 0 (after reset): I/O ports also functioning as WDT output pin (BUZZ) and interrupt input pin ( $\overline{IRQ2}$ ) When BRLE = 1: $\overline{BREQ}$ input, $\overline{BACK}$ output, and interrupt input pin ( $\overline{IRQ2}$ )			I/O ports also functioning as WDT output pin (BUZZ) and interrupt input pin ( $\overline{IRQ2}$ )
Port G	<ul style="list-style-type: none"> <li>4-bit I/O port</li> <li>Schmitt-triggered input (IRQ7)</li> </ul>	PG4/ $\overline{CS0}$	When DDR = 0*1: Input port When DDR = 1*2: $\overline{CS0}$ output			I/O port
		PG3/ $\overline{CS1}$ PG2/ $\overline{CS2}$ PG1/ $\overline{CS3}$ / $\overline{IRQ7}$	When DDR = 0 (after reset): Input ports also functioning as interrupt input pin ( $\overline{IRQ7}$ ) When DDR = 1: CS1, CS2, CS3 output and interrupt input pin ( $\overline{IRQ7}$ )			I/O ports also functioning as interrupt input pin ( $\overline{IRQ7}$ )
	<ul style="list-style-type: none"> <li>1-bit input port (dedicated internal I/O port for the FLEX™ decoder II interface)</li> </ul>	PG0/ $\overline{IRQ6}$	Input port also functioning as interrupt input pin ( $\overline{IRQ6}$ )			

Notes: \*1 After mode 6 reset

\*2 After mode 4 or 5 reset

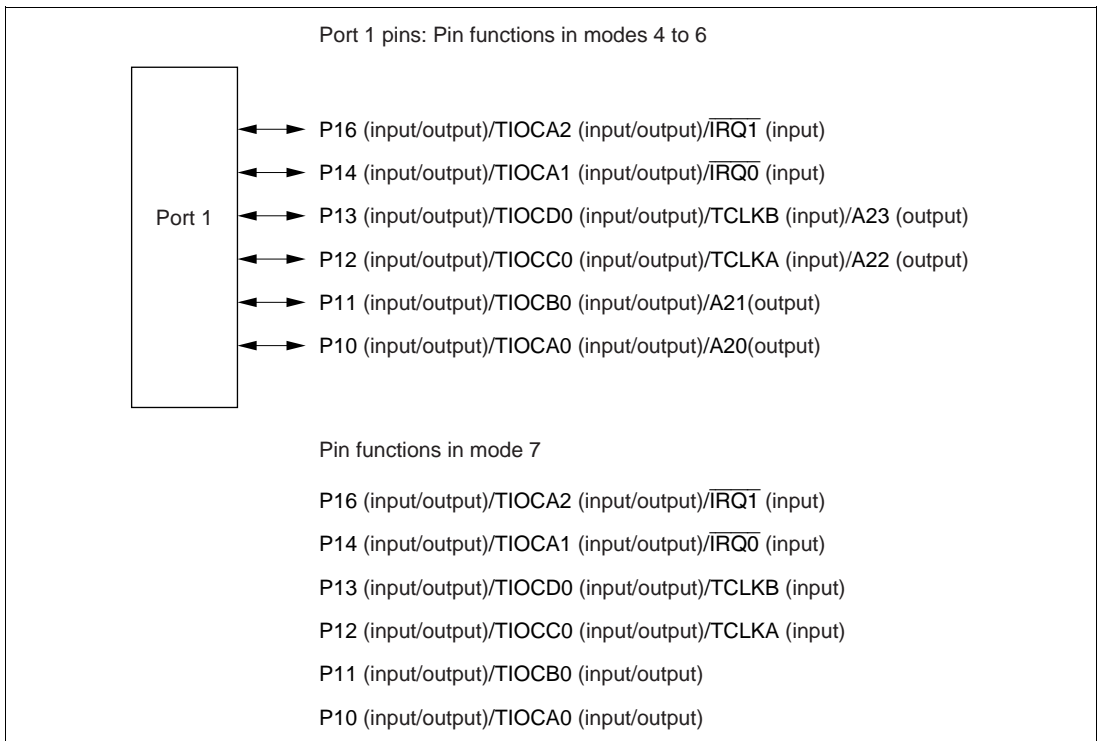
## 9.2 Port 1

### 9.2.1 Overview

Port 1 is a 6-bit I/O port. Port 1 pins also function as TPU I/O pins (TCLKA, TCLKB, TIOCA0, TIOCB0, TIOCC0, TIOCD0, TIOCA1, and TIOCA2), external interrupt pins ( $\overline{\text{IRQ0}}$  and  $\overline{\text{IRQ1}}$ ), and address bus output pins (A23 to A20). Port 1 pin functions depend on the operating mode.

The interrupt input pins ( $\overline{\text{IRQ0}}$  and  $\overline{\text{IRQ1}}$ ) are Schmitt-triggered inputs.

Figure 9.1 shows the port 1 pin configuration.



**Figure 9.1 Port 1 Pin Functions**



## 9.2.2 Register Configuration

Table 9.2 shows the port 1 register configuration.

**Table 9.2 Port 1 Registers**

Name	Abbreviation	R/W	Initial Value* <sup>2</sup>	Address* <sup>1</sup>
Port 1 data direction register	P1DDR	W	H'00	H'FE30
Port 1 data register	P1DR	R/W	H'00	H'FF00
Port 1 register	PORT1	R	Undefined	H'FFB0

Notes: \*1 Lower 16 bits of the address.

\*2 Value of bits 6 and 4 to 0.

### Port 1 Data Direction Register (P1DDR)

Bit	:	7	6	5	4	3	2	1	0
		—	P16DDR	—	P14DDR	P13DDR	P12DDR	P11DDR	P10DDR
Initial value	:	Undefined	0	Undefined	0	0	0	0	0
R/W	:	W	W	W	W	W	W	W	W

P1DDR is an 8-bit write-only register, the individual bits of which specify input or output for the pins of port 1. P1DDR cannot be read; if it is, an undefined value will be read. Bits 7 and 5 are reserved; these bits should always be written with 0.

P1DDR is initialized to H'00 by a power-on reset and in hardware standby mode. It retains its previous state in software standby mode.

The OPE bit in SBYCR is used to select whether the address output pins retain their output state or become high-impedance when a transition is made to software standby mode.

#### (a) Modes 4, 5, and 6

If address output is enabled by the setting of bits AE3 to AE0 in PFCR, pins P13 to P10 are address outputs. Pins P16 and P15, and pins P13 to P10 when address output is disabled, are output ports when the corresponding P1DDR bits are set to 1, and input ports when the corresponding P1DDR bits are cleared to 0.

#### (b) Mode 7

Setting a P1DDR bit to 1 makes the corresponding port 1 pin an output port, while clearing the bit to 0 makes the pin an input port.

## Port 1 Data Register (P1DR)

Bit	:	7	6	5	4	3	2	1	0
		—	P16DR	—	P14DR	P13DR	P12DR	P11DR	P10DR
Initial value	:	Undefined	0	Undefined	0	0	0	0	0
R/W	:	R/W	R/W	R/W	R/W	R/W	R/W	R/W	R/W

P1DR is an 8-bit readable/writable register that stores output data for the port 1 pins (P16, P14 to P10). Bits 7 and 5 are reserved; these bits should always be written with 0 and will return an undefined value if read.

P1DR is initialized to H'00 by a power-on reset and in hardware standby mode. It retains its previous state in software standby mode.

## Port 1 Register (PORT1)

Bit	:	7	6	5	4	3	2	1	0
		—	P16	—	P14	P13	P12	P11	P10
Initial value	:	Undefined	—*	Undefined	—*	—*	—*	—*	—*
R/W	:	—	R	—	R	R	R	R	R

Note: \* Determined by the state of pins P16, P14 to P10.

PORT1 is an 8-bit read-only register that shows the pin states. It cannot be written to. Writing of output data for the port 1 pins (P16, P14 to P10) must always be performed on P1DR. Bits 7 and 5 are reserved; these bits will return an undefined value if read.

If a port 1 read is performed while P1DDR bits are set to 1, the P1DR values are read. If a port 1 read is performed while P1DDR bits are cleared to 0, the pin states are read.

After a power-on reset and in hardware standby mode, PORT1 contents are determined by the pin states, as P1DDR and P1DR are initialized. PORT1 retains its previous state in software standby mode.

### 9.2.3 Pin Functions

Port 1 pins also function as TPU I/O pins (TCLKA, TCLKB, TIOCA0, TIOCB0, TIOCC0, TIOCD0, TIOCA1, and TIOCA2), external interrupt input pins ( $\overline{\text{IRQ0}}$  and  $\overline{\text{IRQ1}}$ ), and address output pins (A23 to A20). Port 1 pin functions are shown in table 9.3.

**Table 9.3 Port 1 Pin Functions**

**Pin Pin Functions and Selection Method**

P16/  
TIOCA2/  
 $\overline{\text{IRQ1}}$  The pin function is switched as shown below according to the combination of the TPU channel 2 settings (bits MD3 to MD0 in TMDR2, bits IOA3 to IOA0 in TIOR2, and bits CCLR1 and CCLR0 in TCR2) and bit P16DDR.

TPU channel 2 settings	(1) in table below	(2) in table below	
P16DDR	—	0	1
Pin function	TIOCA2 output	P16 input	P16 output
		TIOCA2 input* <sup>1</sup>	
	$\overline{\text{IRQ1}}$ input* <sup>2</sup>		

Notes: \*1 TIOCA2 input when MD3 to MD0 = B'0000 or B'01xx and IOA3 = 1.

\*2 When used as an external interrupt pin, do not use for another function.

TPU channel 2 settings	(2)	(1)	(2)	(1)	(1)	(2)
MD3 to MD0	B'0000, B'01xx		B'001x	B'0010	B'0011	
IOA3 to IOA0	B'0000 B'0100 B'1xxx	B'0001 to B'0011 B'0101 to B'0111	B'xx00	Other than B'xx00	Other than B'xx00	
CCLR1, CCLR0	—	—	—	—	Other than B'01	B'01
Output function	—	Output compare output	—	PWM mode 1 output	PWM mode 2 output	—

x: Don't care

## Pin Pin Functions and Selection Method

P14/  
TIOCA1/  
 $\overline{\text{IRQ0}}$  The pin function is switched as shown below according to the combination of the TPU channel 1 settings (bits MD3 to MD0 in TMDR1, bits IOA3 to IOA0 in TIOR1, and bits CCLR1 and CCLR0 in TCR1) and bit P14DDR.

TPU channel 1 settings	(1) in table below	(2) in table below	
P14DDR	—	0	1
Pin function	TIOCA1 output	P14 input	P14 output
		TIOCA1 input* <sup>1</sup>	
	$\overline{\text{IRQ0}}$ input* <sup>2</sup>		

Notes: \*1 TIOCA1 input when MD3 to MD0 = B'0000 or B'01xx and IOA3 to IOA0 = B'10xx.

\*2 When used as an external interrupt pin, do not use for another function.

TPU channel 1 settings	(2)	(1)	(2)	(1)	(1)	(2)
MD3 to MD0	B'0000, B'01xx		B'001x	B'0010	B'0011	
IOA3 to IOA0	B'0000 B'0100 B'1xxx	B'0001 to B'0011 B'0101 to B'0111	B'xx00	Other than B'xx00	Other than B'xx00	
CCLR1, CCLR0	—	—	—	—	Other than B'01	B'01
Output function	—	Output compare output	—	PWM mode 1 output	PWM mode 2 output	—

x: Don't care

## Pin Functions and Selection Method

P13/  
TIOCD0/  
TCLKB/  
A23

The pin function is switched as shown below according to the combination of the operating mode, the TPU channel 0 settings (bits MD3 to MD0 in TMDR0, bits IOD3 to IOD0 in TIOR0L, and bits CCLR2 to CCLR0 in TCR0), bits TPSC2 to TPSC0 in TCR0 to TCR2, bits AE3 to AE0 in PFCR, and bit P13DDR.

Operating mode	Modes 4, 5, 6				Mode 7		
AE3 to AE0	Other than B'1111			B'1111	—		
TPU channel 0 settings	(1) in table below	(2) in table below		—	(1) in table below	(2) in table below	
P13DDR	—	0	1	—	—	0	1
Pin function	TIOCD0 output	P13 input	P13 output	—	TIOCD0 output	P13 input	P13 output
		TIOCD0 input*1		—		TIOCD0 input*1	
	TCLKB input*2			A23 output	TCLKB input*2		

Notes: \*1 TIOCD0 input when MD3 to MD0 = B'0000 and IOD3 to IOD0 = B'10xx.

\*2 TCLKB input when the setting for any of TCR0 to TCR2 is: TPSC2 to TPSC0 = B'101.

Also, TCLKB input when channel 1 is set to phase counting mode.

TPU channel 0 settings	(2)	(1)	(2)	(2)	(1)	(2)
MD3 to MD0	B'0000		B'0010	B'0011		
IOD3 to IOD0	B'0000 B'0100 B'1xxx	B'0001 to B'0011 B'0101 to B'0111		—	B'xx00	Other than B'xx00
CCLR2 to CCLR0	—	—	—	—	Other than B'110	B'110
Output function	—	Output compare output		—	PWM mode 2 output	—

x: Don't care

## Pin Pin Functions and Selection Method

P12/  
TIOCC0/  
TCLKA/  
A22

The pin function is switched as shown below according to the combination of the operating mode, the TPU channel 0 settings (bits MD3 to MD0 in TMDR0, bits IOC3 to IOC0 in TIOR0L, and bits CCLR2 to CCLR0 in TCR0), bits TPSC2 to TPSC0 in TCR0 to TCR2, bits AE3 to AE0 in PFCR, and bit P12DDR.

Operating mode	Modes 4, 5, 6				Mode 7		
AE3 to AE0	Other than B'1111			B'1111	—		
TPU channel 0 settings	(1) in table below	(2) in table below		—	(1) in table below	(2) in table below	
P12DDR	—	0	1	—	—	0	1
Pin function	TIOCC0 output	P12 input	P12 output	—	TIOCC0 output	P12 input	P12 output
		TIOCC0 input* <sup>1</sup>		—		TIOCC0 input* <sup>1</sup>	
	TCLKA input* <sup>2</sup>			A22 output	TCLKA input* <sup>2</sup>		

Notes: \*1 TIOCC0 input when MD3 to MD0 = B'0000 and IOC3 to IOC0 = B'10xx.

\*2 TCLKA input when the setting for any of TCR0 to TCR2 is: TPSC2 to TPSC0 = B'100.

Also, TCLKA input when channel 1 is set to phase counting mode.

TPU channel 0 settings	(2)	(1)	(2)	(1)	(1)	(2)
MD3 to MD0	B'0000		B'001x	B'0010	B'0011	
IOC3 to IOC0	B'0000 B'0100 B'1xxx	B'0001 to B'0011 B'0101 to B'0111	B'xx00	Other than B'xx00	Other than B'xx00	
CCLR2 to CCLR0	—	—	—	—	Other than B'101	B'101
Output function	—	Output compare output	—	PWM mode 1 output* <sup>3</sup>	PWM mode 2 output	—

x: Don't care

Note: \*3 Output is disabled for TIOCD0.

When BFA = 1 or BFB = 1 in TMDR0, output is disabled and the settings in (2) apply.

## Pin Functions and Selection Method

P11/  
TIOCB0/  
A21

The pin function is switched as shown below according to the combination of the operating mode, the TPU channel 0 settings (bits MD3 to MD0 in TMDR0 and bits IOB3 to IOB0 in TIOR0H), bits AE3 to AE0 in PFCR, and bit P11DDR.

Operating mode	Modes 4, 5, 6				Mode 7		
AE3 to AE0	Other than B'111x			B'111x	—		
TPU channel 0 settings	(1) in table below	(2) in table below		—	(1) in table below	(2) in table below	
P11DDR	—	0	1	—	—	0	1
Pin function	TIOCB0 output	P11 input	P11 output	—	TIOCB0 output	P11 input	P11 output
		TIOCB0 input*		A21 output		TIOCB0 input*	

Note: \* TIOCB0 input when MD3 to MD0 = B'0000 and IOB3 to IOB0 = B'10xx.

TPU channel 0 settings	(2)	(1)	(2)	(2)	(1)	(2)
MD3 to MD0	B'0000		B'0010	B'0011		
IOB3 to IOB0	B'0000 B'0100 B'1xxx	B'0001 to B'0011 B'0101 to B'0111		—	B'xx00	Other than B'xx00
CCLR2 to CCLR0	—	—	—	—	Other than B'010	B'010
Output function	—	Output compare output		—	PWM mode 2 output	—

x: Don't care

## Pin Pin Functions and Selection Method

P10/  
TIOCA0/  
A20

The pin function is switched as shown below according to the combination of the operating mode, the TPU channel 0 settings (bits MD3 to MD0 in TMDR0, bits IOA3 to IOA0 in TIOR0H, and bits CCLR2 to CCLR0 in TCR0), bits AE3 to AE0 in PFCR, and bit P10DDR.

Operating mode	Modes 4, 5, 6				Mode 7		
AE3 to AE0	Other than (B'1101 or B'111x)			B'1101 or B'111x	—		
TPU channel 0 settings	(1) in table below	(2) in table below		—	(1) in table below	(2) in table below	
P10DDR	—	0	1	—	—	0	1
Pin function	TIOCA0 output	P10 input	P10 output	—	TIOCA0 output	P10 input	P10 output
		TIOCA0 input* <sup>1</sup>		A20 output		TIOCA0 input* <sup>1</sup>	

Note: \*1 TIOCA0 input when MD3 to MD0 = B'0000 and IOA3 to IOA0 = B'10xx.

TPU channel 0 settings	(2)	(1)	(2)	(1)	(1)	(2)
MD3 to MD0	B'0000		B'001x	B'0010	B'0011	
IOA3 to IOA0	B'0000 B'0100 B'1xxx	B'0001 to B'0011 B'0101 to B'0111	B'xx00	Other than B'xx00	Other than B'xx00	
CCLR2 to CCLR0	—	—	—	—	Other than B'001	B'001
Output function	—	Output compare output	—	PWM mode 1 output* <sup>2</sup>	PWM mode 2 output	—

x: Don't care

Note: \*2 Output is disabled for TIOCB0.



## 9.3 Port 3\*

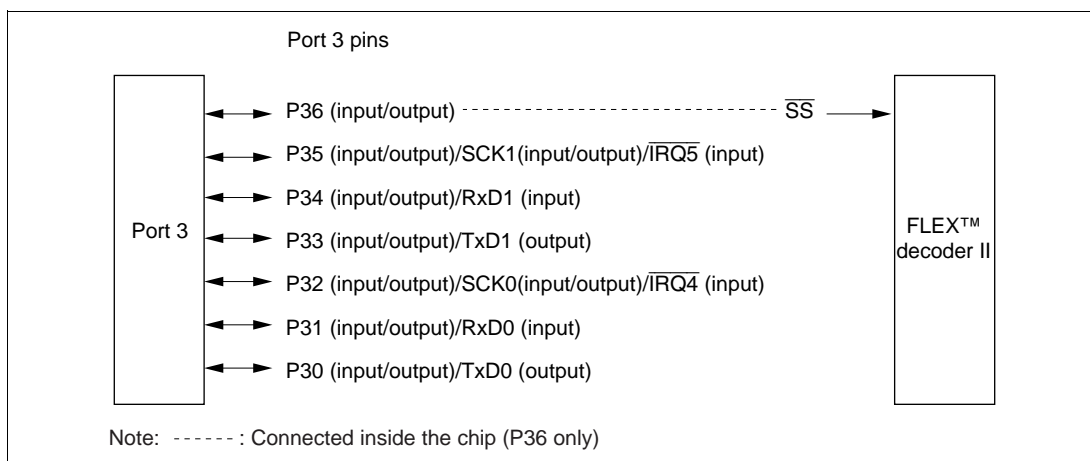
Note: \* P36, only is a internal I/O port.

### 9.3.1 Overview

Port 3 consists of a 6-bit I/O port and on-chip 1-bit I/O port that is a dedicated port for the FLEX™ decoder II interface. Port 3 pins also function as SCI I/O pins (TxD0, RxD0, SCK0, TxD1, RxD1, and SCK1) and external interrupt input pins ( $\overline{\text{IRQ4}}$  and  $\overline{\text{IRQ5}}$ ). Port 3 pin functions are the same in all operating modes.

The interrupt input pins ( $\overline{\text{IRQ4}}$  and  $\overline{\text{IRQ5}}$ ) are Schmitt-triggered inputs.

Figure 9.2 shows the port 3 pin configuration.



**Figure 9.2 Port 3 Pin Functions**

### 9.3.2 Register Configuration

Table 9.4 shows the port 3 register configuration.

**Table 9.4 Port 3 Registers**

Name	Abbreviation	R/W	Initial Value* <sup>2</sup>	Address* <sup>1</sup>
Port 3 data direction register	P3DDR	W	H'00	H'FE32
Port 3 data register	P3DR	R/W	H'00	H'FF02
Port 3 register	PORT3	R	H'00	H'FFB2
Port 3 open-drain control register	P3ODR	R/W	H'00	H'FE46

Notes: \*1 Lower 16 bits of the address.

\*2 Value of bits 6 to 0.

#### Port 3 Data Direction Register (P3DDR)

Bit	:	7	6	5	4	3	2	1	0
		—	P36DDR	P35DDR	P34DDR	P33DDR	P32DDR	P31DDR	P30DDR
Initial value	:	Undefined	0	0	0	0	0	0	0
R/W	:	—	W	W	W	W	W	W	W

P3DDR is an 8-bit write-only register, the individual bits of which specify input or output for the pins of port 3. P3DDR cannot be read; if it is, an undefined value will be returned. Bit 7 is reserved; this bit cannot be modified and will return an undefined value if read.

Setting a P3DDR bit to 1 makes the corresponding port 3 pin an output pin, while clearing the bit to 0 makes the pin an input pin.

P3DDR is initialized to H'00 by a power-on reset and in hardware standby mode. It retains its previous state in software standby mode.

### Port 3 Data Register (P3DR)

Bit	:	7	6	5	4	3	2	1	0
		—	P36DR	P35DR	P34DR	P33DR	P32DR	P31DR	P30DR
Initial value	:	Undefined	0	0	0	0	0	0	0
R/W	:	—	R/W	R/W	R/W	R/W	R/W	R/W	R/W

P3DR is an 8-bit readable/writable register that stores output data for the port 3 pins (P36 to P30). Bit 7 is reserved; this bit cannot be modified and will return an undefined value if read.

P3DR is initialized to H'00 by a power-on reset and in hardware standby mode. It retains its previous state in software standby mode.

### Port 3 Register (PORT3)

Bit	:	7	6	5	4	3	2	1	0
		—	—	P35	P34	P33	P32	P31	P30
Initial value	:	Undefined	Undefined	—*	—*	—*	—*	—*	—*
R/W	:	—	R	R	R	R	R	R	R

Note: \* Determined by the state of pins P35 to P30.

PORT3 is an 8-bit read-only register that shows the pin states. It cannot be written to. Writing of output data for the port 3 pins (P35 to P30) must always be performed on P3DR. Bits 7 and 6 are reserved; these bits will return an undefined value if read.

If a port 3 read is performed while P3DDR bits are set to 1, the P3DR values are read. If a port 3 read is performed while P3DDR bits are cleared to 0, the pin states are read.

After a power-on reset and in hardware standby mode, PORT3 contents are determined by the pin states, as P3DDR and P3DR are initialized. PORT3 retains its previous state in software standby mode.

### Port 3 Open-Drain Control Register (P3ODR)

Bit	:	7	6	5	4	3	2	1	0
		—	—	P35ODR	P34ODR	P33ODR	P32ODR	P31ODR	P30ODR
Initial value	:	Undefined	Undefined	0	0	0	0	0	0
R/W	:	—	R/W	R/W	R/W	R/W	R/W	R/W	R/W

P3ODR is an 8-bit readable/writable register that controls the PMOS on/off status for each port 3 pin (P35 to P30). Bits 7 and 6 are reserved; these bits should always be written with 0 and will return an undefined value if read.

Setting a P3ODR bit to 1 makes the corresponding port 3 pin an NMOS open-drain output pin, while clearing the bit to 0 makes the pin a CMOS output pin.

P3ODR is initialized to H'00 by a power-on reset and in hardware standby mode. It retains its previous state in software standby mode.

#### 9.3.3 Pin Functions

Port 3 pins also function as SCI I/O pins (TxD0, RxD0, SCK0, TxD1, RxD1, and SCK1) and interrupt input pins ( $\overline{\text{IRQ4}}$  and  $\overline{\text{IRQ5}}$ ). Port 3 pin functions are shown in table 9.5.

**Table 9.5 Port 3 Pin Functions****Pin Pin Functions and Selection Method**

P36 The pin function is switched as shown below according to the setting of bit P36DDR.

(dedicated internal I/O port for the FLEX™ decoder II interface)

P36DDR	0	1
Pin function	P36 input	P36 output

P35/SCK1/  
IRQ5 The pin function is switched as shown below according to the combination of bit C/A in SMR, bits CKE0 and CKE1 in SCR of SCI1, and bit P35DDR.

CKE1	0			1	
C/A	0		1	—	—
CKE0	0	1	—	—	—
P35DDR	0	1	—	—	—
Pin function	P35 input	P35 output* <sup>1</sup>	SCK1 output* <sup>1</sup>	SCK1 output* <sup>1</sup>	SCK1 input
	IRQ5 input* <sup>2</sup>				

Notes: \*1 NMOS open-drain output when P35ODR = 1.

\*2 When used as an external interrupt pin, do not use for another function.

P34/RxD1 The pin function is switched as shown below according to the combination of bit RE in SCR of SCI1 and bit P34DDR.

RE	0		1
P34DDR	0	1	—
Pin function	P34 input	P34 output*	RxD1 input

Note: \*NMOS open-drain output when P34ODR = 1.

P33/TxD1 The pin function is switched as shown below according to the combination of bit TE in SCR of SCI1 and bit P33DDR.

TE	0		1
P33DDR	0	1	—
Pin function	P33 input	P33 output*	TxD1 output*

Note: \*NMOS open-drain output when P33ODR = 1.

## Pin Pin Functions and Selection Method

**P32/SCK0/IRQ4** The pin function is switched as shown below according to the combination of bit  $C/\bar{A}$  in SMR, bits CKE0 and CKE1 in SCR of SCIO, and bit P32DDR.

CKE1	0			1	
$C/\bar{A}$	0		1	—	
CKE0	0	1	—	—	—
P32DDR	0	1	—	—	—
Pin function	P32 input	P32 output* <sup>1</sup>	SCK0 output* <sup>1</sup>	SCK0 output* <sup>1</sup>	SCK0 input
	IRQ4 input* <sup>2</sup>				

Notes: \*1 NMOS open-drain output when P32ODR = 1.

\*2 When used as an external interrupt pin, do not use for another function.

**P31/RxD0** The pin function is switched as shown below according to the combination of bit RE in SCR of SCIO and bit P31DDR.

RE	0		1
P31DDR	0	1	—
Pin function	P31 input	P31 output*	RxD0 input

Note: \* NMOS open-drain output when P31ODR = 1.

**P30/TxD0** The pin function is switched as shown below according to the combination of bit TE in SCR of SCIO and bit P30DDR.

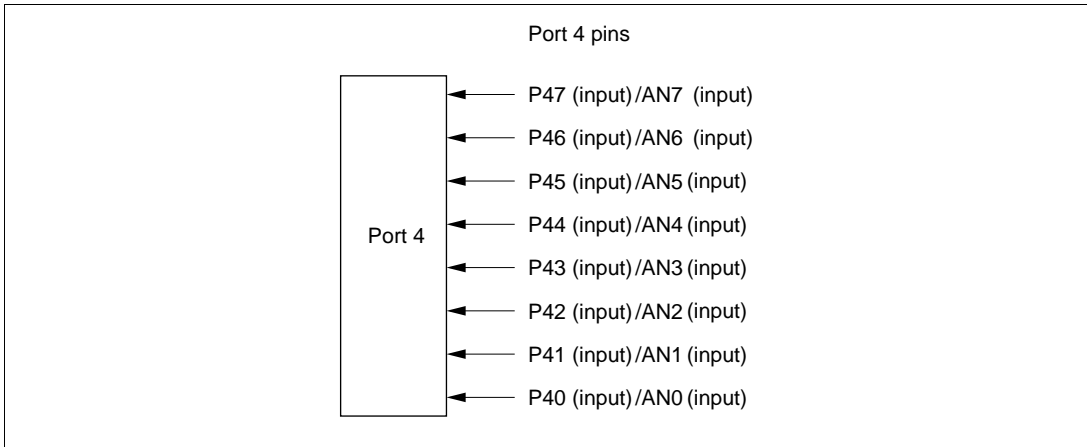
TE	0		1
P30DDR	0	1	—
Pin function	P30 input	P30 output*	TxD0 output*

Note: \* NMOS open-drain output when P30ODR = 1.

## 9.4 Port 4

### 9.4.1 Overview

Port 4 is an 8-bit input-only port. Port 4 pins also function as A/D converter analog input pins (AN0 to AN7). Port 4 pin functions are the same in all operating modes. Figure 9.3 shows the port 4 pin configuration.



**Figure 9.3 Port 4 Pin Functions**

### 9.4.2 Register Configuration

Table 9.6 shows the port 4 register configuration. Port 4 is an input-only register, and does not have a data direction register or data register.

**Table 9.6 Port 4 Registers**

Name	Abbreviation	R/W	Initial Value	Address*
Port 4 register	PORT4	R	Undefined	H'FFB3

Note: \* Lower 16 bits of the address.

### Port 4 Register (PORT4)

Bit	:	7	6	5	4	3	2	1	0
		P47	P46	P45	P44	P43	P42	P41	P40
Initial value	:	—*	—*	—*	—*	—*	—*	—*	—*
R/W	:	R	R	R	R	R	R	R	R

Note: \* Determined by the state of pins P47 to P40.

PORT4 is an 8-bit read-only register. The pin states are always read when a port 4 read is performed. This register cannot be written to.

### 9.4.3 Pin Functions

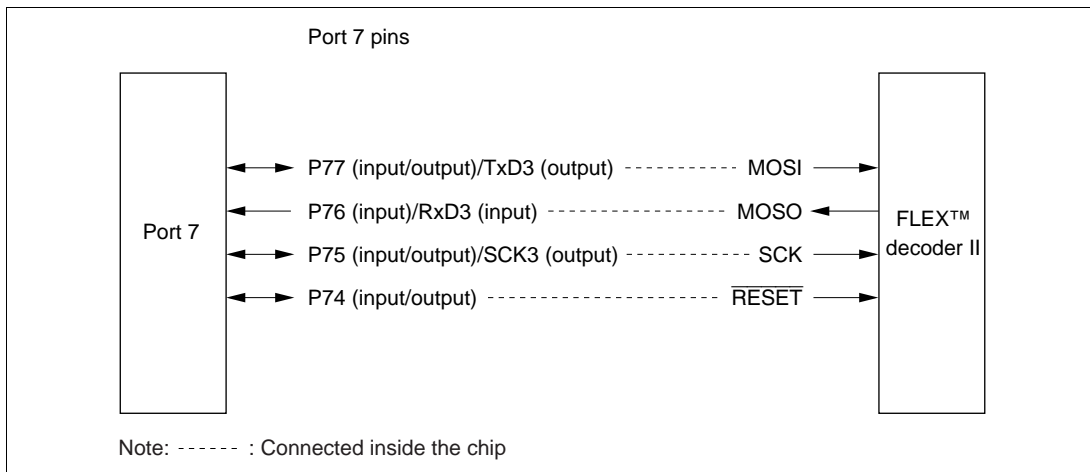
Port 4 pins also function as A/D converter analog input pins (AN0 to AN7).

## 9.5 Port 7 [Internal I/O Port]

### 9.5.1 Overview

Port 7 is a 4-bit on-chip dedicated I/O port for the FLEX™ decoder II. Port 7 pins also function as SCI I/O pins (SCK3, RxD3, and TxD3). The functions of pins P77 to P74 are the same in all operating mode.

Figure 9.4 shows the port 7 pin configuration.



**Figure 9.4 Port 7 Pin Functions**



## 9.5.2 Register Configuration

Table 9.7 shows the port 7 register configuration.

**Table 9.7 Port 7 Registers**

Name	Abbreviation	R/W	Initial Value* <sup>2</sup>	Address* <sup>1</sup>
Port 7 data direction register	P7DDR	W	H'00	H'FE36
Port 7 data register	P7DR	R/W	H'00	H'FF06
Port 7 register	PORT7	R	Undefined	H'FFB6

Notes: \*1 Lower 16 bits of the address.

\*2 Value of bits 7, 5, and 4.

### Port 7 Data Direction Register (P7DDR)

Bit	:	7	6	5	4	3	2	1	0
		P77DDR	—	P75DDR	P74DDR	—	—	—	—
Initial value	:	0	Undefined	0	0	Undefined	Undefined	Undefined	Undefined
R/W	:	W	W	W	W	W	W	W	W

P7DDR is an 8-bit write-only register, the individual bits of which specify input or output for the pins of port 7. P7DDR cannot be read; if it is, an undefined value will be read. Bits 6, 3 to 0 are reserved; these bits should always be written with 0.

Setting a P7DDR bit to 1 makes the corresponding port 7 pin an output pin, while clearing the bit to 0 makes the pin an input pin.

P7DDR is initialized to H'00 by a power-on reset and in hardware standby mode. It retains its previous state in software standby mode.

### Port 7 Data Register (P7DR)

Bit	:	7	6	5	4	3	2	1	0
		P77DR	—	P75DR	P74DR	—	—	—	—
Initial value	:	0	Undefined	0	0	Undefined	Undefined	Undefined	Undefined
R/W	:	R/W	R/W	R/W	R/W	R/W	R/W	R/W	R/W

P7DR is an 8-bit readable/writable register that stores output data for the port 7 pins (P77, P75, P74). Bits 6, 3 to 0 are reserved; these bits should always be written with 0 and will return an undefined value if read.

P7DR is initialized to H'00 by a power-on reset and in hardware standby mode. It retains its previous state in software standby mode.

### Port 7 Register (PORT7)

Bit	:	7	6	5	4	3	2	1	0
		—	P76	—	—	—	—	—	—
Initial value	:	Undefined	—*	Undefined	Undefined	Undefined	Undefined	Undefined	Undefined
R/W	:	R	R	R	R	R	R	R	R

Note: \* Determined by the state of MISO of FLEX™ decoder II.

PORT7 is an 8-bit read-only register. The state of MISO of FLEX™ decoder II is always read when a port 7 read is performed. It cannot be written to. Writing of output data for the port 7 pins (P77, P75, P74) must always be performed on P7DR. Bits 7, 5 to 0 are reserved; these bits will return an undefined value if read.

### 9.5.3 Pin Functions

Port 7 pins also function as SCI I/O pins (SCK3, RxD3, and TxD3). Port 7 pin functions are shown in table 9.8.

**Table 9.8 Port 7 Pin Functions**

**Pin Pin Functions and Selection Method**

**P77/TxD3** The pin function is switched as shown below according to the combination of bit TE in SCR of SCI3 and bit P77DDR.

TE	0		1	
P77DDR	0	1	1	0
Pin function	P77 input	P77 output	TxD3 output	Setting prohibited

**P76/RxD3** The pin function is switched as shown below according to the setting of bit RE in SCR of SCI3.

RE	0	1
Pin function	P76 input	RxD3 input

**P75/SCK3** The pin function is switched as shown below according to the combination of bit  $C/\bar{A}$  in SMR, bits CKE0 and CKE1 of SCR of SCI3, and bit P75DDR.

CKE1	0						1
P75DDR	0			1			—
$C/\bar{A}$	0		1	0		1	—
CKE0	0	1	—	0	1	—	—
Pin function	P75 input	Setting prohibited		P75 output	SCK3 output	SCK3 output	Setting prohibited

**P74** The pin function is switched as shown below according to the setting of the bit P74DDR.

P74DDR	0	1
Pin function	P74 input	P74 output

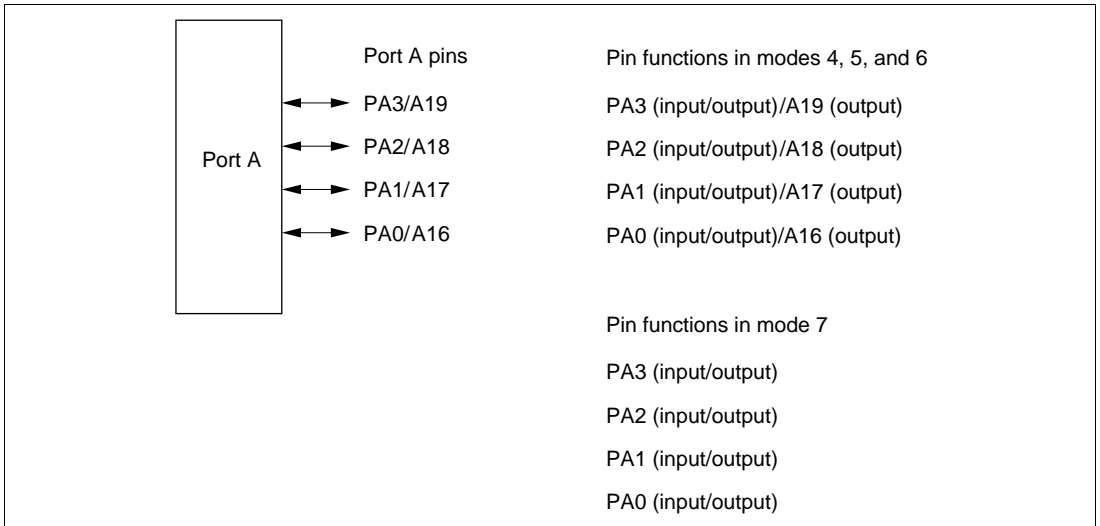
## 9.6 Port A

### 9.6.1 Overview

Port A is a 4-bit I/O port. Port A pins also function as address bus outputs. The pin functions depend on the operating mode.

Port A has a built-in MOS input pull-up function that can be controlled by software.

Figure 9.5 shows the port A pin configuration.



**Figure 9.5 Port A Pin Functions**

### 9.6.2 Register Configuration

Table 9.9 shows the port A register configuration.

**Table 9.9 Port A Registers**

Name	Abbreviation	R/W	Initial Value <sup>*2</sup>	Address <sup>*1</sup>
Port A data direction register	PADDR	W	H'0	H'FE39
Port A data register	PADR	R/W	H'0	H'FF09
Port A register	PORTA	R	Undefined	H'FFB9
Port A MOS pull-up control register	PAPCR	R/W	H'0	H'FE40
Port A open-drain control register	PAODR	R/W	H'0	H'FE47

Notes: \*1 Lower 16 bits of the address.

\*2 Value of bits 3 to 0.

## Port A Data Direction Register (PADDR)

Bit	:	7	6	5	4	3	2	1	0
		—	—	—	—	PA3DDR	PA2DDR	PA1DDR	PA0DDR
Initial value	:	Undefined	Undefined	Undefined	Undefined	0	0	0	0
R/W	:	—	—	—	—	W	W	W	W

PADDR is an 8-bit write-only register, the individual bits of which specify input or output for the pins of port A. PADDR cannot be read; if it is, an undefined value will be read.

Bits 7 to 4 are reserved; these bits cannot be modified.

PADDR is initialized to H'0 (bits 3 to 0) by a power-on reset and in hardware standby mode. It retains its previous state in software standby mode. The OPE bit in SBYCR is used to select whether the address output pins retain their output state or become high-impedance when a transition is made to software standby mode.

### (a) Modes 4, 5, and 6

If address output is enabled by the setting of bits AE3 to AE0 in PFCR, the corresponding port A pins are address outputs.

When address output is disabled, setting a PADDR bit to 1 makes the corresponding port A pin an output port, while clearing the bit to 0 makes the pin an input port.

### (b) Mode 7

Setting a PADDR bit to 1 makes the corresponding port A pin an output port, while clearing the bit to 0 makes the pin an input port.

## Port A Data Register (PADR)

Bit	:	7	6	5	4	3	2	1	0
		—	—	—	—	PA3DR	PA2DR	PA1DR	PA0DR
Initial value	:	Undefined	Undefined	Undefined	Undefined	0	0	0	0
R/W	:	—	—	—	—	R/W	R/W	R/W	R/W

PADR is an 8-bit readable/writable register that stores output data for the port A pins (PA3 to PA0).

Bits 7 to 4 are reserved; these bits cannot be modified and will return an undefined value if read.

PADR is initialized to H'0 (bits 3 to 0) by a power-on reset and in hardware standby mode. It retains its previous state in software standby mode.

## Port A Register (PORTA)

Bit	:	7	6	5	4	3	2	1	0
		—	—	—	—	PA3	PA2	PA1	PA0
Initial value	:	Undefined	Undefined	Undefined	Undefined	—*	—*	—*	—*
R/W	:	—	—	—	—	R	R	R	R

Note: \* Determined by the state of pins PA3 to PA0.

PORTA is an 8-bit read-only register that shows the pin states. It cannot be written to. Writing of output data for the port A pins (PA3 to PA0) must always be performed on PADDR.

Bits 7 to 4 are reserved; these bits will return an undefined value if read.

If a port A read is performed while PADDR bits are set to 1, the PADDR values are read. If a port A read is performed while PADDR bits are cleared to 0, the pin states are read.

After a power-on reset and in hardware standby mode, PORTA contents are determined by the pin states, as PADDR and PADDR are initialized. PORTA retains its previous state in software standby mode.

## Port A MOS Pull-Up Control Register (PAPCR)

Bit	:	7	6	5	4	3	2	1	0
		—	—	—	—	PA3PCR	PA2PCR	PA1PCR	PA0PCR
Initial value	:	Undefined	Undefined	Undefined	Undefined	0	0	0	0
R/W	:	—	—	—	—	R/W	R/W	R/W	R/W

PAPCR is an 8-bit readable/writable register that controls the MOS input pull-up function incorporated into port A on a bit-by-bit basis.

Bits 7 to 4 are reserved; these bits cannot be modified and will return an undefined value if read.

PAPCR is valid for port input pins. When a PADDR bit is cleared to 0 (input port setting), setting the corresponding PAPCR bit to 1 turns on the MOS input pull-up for the corresponding pin.

PAPCR is initialized to H'0 (bits 3 to 0) by a power-on reset and in hardware standby mode. It retains its previous state in software standby mode.

## Port A Open-Drain Control Register (PAODR)

Bit	:	7	6	5	4	3	2	1	0
		—	—	—	—	PA3ODR	PA2ODR	PA1ODR	PA0ODR
Initial value	:	Undefined	Undefined	Undefined	Undefined	0	0	0	0
R/W	:	—	—	—	—	R/W	R/W	R/W	R/W

PAODR is an 8-bit readable/writable register that controls the PMOS on/off status for each port A pin (PA3 to PA0).

Bits 7 to 4 are reserved; these bits cannot be modified and will return an undefined value if read.

PAODR is valid for port output.

Setting a PAODR bit to 1 makes the corresponding port A pin an NMOS open-drain output pin, while clearing the bit to 0 makes the pin a CMOS output pin.

PAODR is initialized to H'0 (bits 3 to 0) by a power-on reset and in hardware standby mode. It retains its previous state in software standby mode.

### 9.6.3 Pin Functions

Port A pins also function as address output pins (A19 to A16). Port A pin functions are shown in table 9.10.

**Table 9.10 Port A Pin Functions**

**Pin Pin Functions and Selection Method**

PA3/A19 The pin function is switched as shown below according to the combination of the operating mode, PFCR setting, and bit PA3DDR.

Operating mode	Modes 4 to 6			Mode 7	
AE3 to AE0 in PFCR	11xx	Other than 11xx		—	
PA3DDR	—	0	1	0	1
Pin function	A19 output	PA3 input	PA3 output*	PA3 input	PA3 output*

x: Don't care

Note: \* NMOS open-drain output when PA3ODR = 1 in PAODR.

PA2/A18 The pin function is switched as shown below according to the combination of the operating mode, PFCR setting, and bit PA2DDR.

Operating mode	Modes 4 to 6			Mode 7	
AE3 to AE0 in PFCR	1011 or 11xx	Other than (1011 or 11xx)		—	
PA2DDR	—	0	1	0	1
Pin function	A18 output	PA2 input	PA2 output*	PA2 input	PA2 output*

x: Don't care

Note: \* NMOS open-drain output when PA2ODR = 1 in PAODR.

PA1/A17 The pin function is switched as shown below according to the combination of the operating mode, PFCR setting, and bit PA1DDR.

Operating mode	Modes 4 to 6			Mode 7	
AE3 to AE0 in PFCR	101x or 11xx	Other than (101x or 11xx)		—	
PA1DDR	—	0	1	0	1
Pin function	A17 output	PA1 input	PA1 output*	PA1 input	PA1 output*

x: Don't care

Note: \* NMOS open-drain output when PA1ODR = 1 in PAODR.



## Pin Pin Functions and Selection Method

PA0/A16 The pin function is switched as shown below according to the combination of the operating mode, PFCR setting, and bit PA0DDR.

Operating mode	Modes 4 to 6			Mode 7	
AE3 to AE0 in PFCR	Other than (0xxx or 1000)	0xxx or 1000		—	
PA1DDR	—	0	1	0	1
Pin function	A16 output	PA0 input	PA0 output*	PA0 input	PA0 output*

x: Don't care

Note: \* NMOS open-drain output when PA0ODR = 1 in PAODR.

### 9.6.4 MOS Input Pull-Up Function

Port A has a built-in MOS input pull-up function that can be controlled by software. MOS input pull-up can be specified as on or off for individual bits.

With port input pins, when a PADDR bit is cleared to 0, setting the corresponding PAPCR bit to 1 turns on the MOS input pull-up for that pin.

The MOS input pull-up function is in the off state after a power-on reset and in hardware standby mode. The previous state is retained in software standby mode.

Table 9.11 summarizes the MOS input pull-up states.

**Table 9.11 MOS Input Pull-Up States (Port A)**

Pins	Power-On Reset	Hardware Standby Mode	Software Standby Mode	In Other Operations
Address output, port output	OFF	OFF	OFF	OFF
Port input	OFF	OFF	ON/OFF	ON/OFF

Legend:

OFF: MOS input pull-up is always off.

ON/OFF: On when PADDR = 0 and PAPCR = 1; otherwise off.

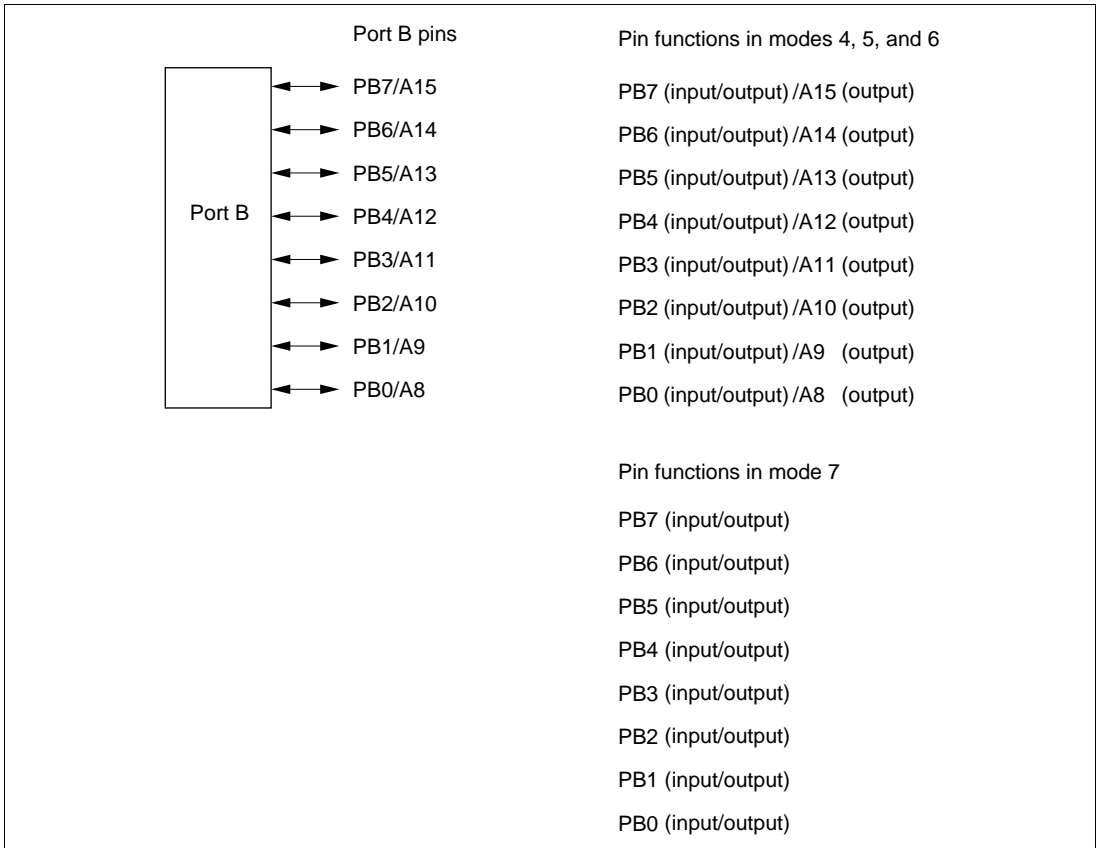
## 9.7 Port B

### 9.7.1 Overview

Port B is an 8-bit I/O port. Port B pins also function as address bus outputs. The pin functions depend on the operating mode.

Port B has a built-in MOS input pull-up function that can be controlled by software.

Figure 9.6 shows the port B pin configuration.



**Figure 9.6 Port B Pin Functions**

## 9.7.2 Register Configuration

Table 9.12 shows the port B register configuration.

**Table 9.12 Port B Registers**

Name	Abbreviation	R/W	Initial Value	Address*
Port B data direction register	PBDDR	W	H'00	H'FE3A
Port B data register	PBDR	R/W	H'00	H'FF0A
Port B register	PORTB	R	Undefined	H'FFBA
Port B MOS pull-up control register	PBPCR	R/W	H'00	H'FE41

Note: \* Lower 16 bits of the address.

### Port B Data Direction Register (PBDDR)

Bit	:	7	6	5	4	3	2	1	0
		PB7DDR	PB6DDR	PB5DDR	PB4DDR	PB3DDR	PB2DDR	PB1DDR	PB0DDR
Initial value	:	0	0	0	0	0	0	0	0
R/W	:	W	W	W	W	W	W	W	W

PBDDR is an 8-bit write-only register, the individual bits of which specify input or output for the pins of port B. PBDDR cannot be read; if it is, an undefined value will be read.

PBDDR is initialized to H'00 by a power-on reset and in hardware standby mode. It retains its previous state in software standby mode. The OPE bit in SBYCR is used to select whether the address output pins retain their output state or become high-impedance when a transition is made to software standby mode.

- Modes 4, 5, and 6

If address output is enabled by the setting of bits AE3 to AE0 in PFCR, the corresponding port B pins are address outputs.

When address output is disabled, setting a PBDDR bit to 1 makes the corresponding port B pin an output port, while clearing the bit to 0 makes the pin an input port.

- Mode 7

Setting a PBDDR bit to 1 makes the corresponding port B pin an output port, while clearing the bit to 0 makes the pin an input port.

## Port B Data Register (PBDR)

Bit	:	7	6	5	4	3	2	1	0
		PB7DR	PB6DR	PB5DR	PB4DR	PB3DR	PB2DR	PB1DR	PB0DR
Initial value :		0	0	0	0	0	0	0	0
R/W	:	R/W	R/W	R/W	R/W	R/W	R/W	R/W	R/W

PBDR is an 8-bit readable/writable register that stores output data for the port B pins (PB7 to PB0).

PBDR is initialized to H'00 by a power-on reset and in hardware standby mode. It retains its previous state in software standby mode.

## Port B Register (PORTB)

Bit	:	7	6	5	4	3	2	1	0
		PB7	PB6	PB5	PB4	PB3	PB2	PB1	PB0
Initial value :		—*	—*	—*	—*	—*	—*	—*	—*
R/W	:	R	R	R	R	R	R	R	R

Note: \* Determined by the state of pins PB7 to PB0.

PORTB is an 8-bit read-only register that shows the pin states. It cannot be written to. Writing of output data for the port B pins (PB7 to PB0) must always be performed on PBDR.

If a port B read is performed while PBDDR bits are set to 1, the PBDR values are read. If a port B read is performed while PBDDR bits are cleared to 0, the pin states are read.

After a power-on reset and in hardware standby mode, PORTB contents are determined by the pin states, as PBDDR and PBDR are initialized. PORTB retains its previous state in software standby mode.

## Port B MOS Pull-Up Control Register (PBPCR)

Bit	:	7	6	5	4	3	2	1	0
		PB7PCR	PB6PCR	PB5PCR	PB4PCR	PB3PCR	PB2PCR	PB1PCR	PB0PCR
Initial value :		0	0	0	0	0	0	0	0
R/W	:	R/W	R/W	R/W	R/W	R/W	R/W	R/W	R/W

PBPCR is an 8-bit readable/writable register that controls the MOS input pull-up function incorporated into port B on a bit-by-bit basis.

PBPCR is valid for port input pins.

When a PBDDR bit is cleared to 0 (input port setting), setting the corresponding PBPCR bit to 1 turns on the MOS input pull-up for the corresponding pin.

PBPCR is initialized to H'00 by a power-on reset and in hardware standby mode. It retains its previous state in software standby mode.

### **9.7.3 Pin Functions**

Port B pins also function as address output pins (A15 to A8). Port B pin functions are shown in table 9.13.

**Table 9.13 Port B Pin Functions****Pin Pin Functions and Selection Method**

PB7/A15 The pin function is switched as shown below according to the combination of the operating mode, PFCR setting, and bit PB7DDR.

Operating mode	Modes 4 to 6			Mode 7	
AE3 to AE0 in PFCR	B'1xxx	Other than B'1xxx		—	
PB7DDR	—	0	1	0	1
Pin function	A15 output	PB7 input	PB7 output	PB7 input	PB7 output

x: Don't care

PB6/A14 The pin function is switched as shown below according to the combination of the operating mode, PFCR setting, and bit PB6DDR.

Operating mode	Modes 4 to 6			Mode 7	
AE3 to AE0 in PFCR	B'0111 or B'1xxx	Other than (B'0111 or B'1xxx)		—	
PB6DDR	—	0	1	0	1
Pin function	A14 output	PB6 input	PB6 output	PB6 input	PB6 output

x: Don't care

PB5/A13 The pin function is switched as shown below according to the combination of the operating mode, PFCR setting, and bit PB5DDR.

Operating mode	Modes 4 to 6			Mode 7	
AE3 to AE0 in PFCR	B'011x or B'1xxx	Other than (B'011x or B'1xxx)		—	
PB5DDR	—	0	1	0	1
Pin function	A13 output	PB5 input	PB5 output	PB5 input	PB5 output

x: Don't care

PB4/A12 The pin function is switched as shown below according to the combination of the operating mode, PFCR setting, and bit PB4DDR.

Operating mode	Modes 4 to 6			Mode 7	
AE3 to AE0 in PFCR	B'0100 or B'00xx	Other than (B'0100 or B'00xx)		—	
PB4DDR	—	0	1	0	1
Pin function	A12 output	PB4 input	PB4 output	PB4 input	PB4 output

x: Don't care

## Pin Pin Functions and Selection Method

PB3/A11 The pin function is switched as shown below according to the combination of the operating mode, PFCR setting, and bit PB3DDR.

Operating mode	Modes 4 to 6			Mode 7	
AE3 to AE0 in PFCR	B'00xx	Other than B'00xx		—	
PB3DDR	—	0	1	0	1
Pin function	A11 output	PB3 input	PB3 output	PB3 input	PB3 output

x: Don't care

PB2/A10 The pin function is switched as shown below according to the combination of the operating mode, PFCR setting, and bit PB2DDR.

Operating mode	Modes 4 to 6			Mode 7	
AE3 to AE0 in PFCR	B'0010 or B'000x	Other than B'0010 or B'000x		—	
PB2DDR	—	0	1	0	1
Pin function	A10 output	PB2 input	PB2 output	PB2 input	PB2 output

x: Don't care

PB1/A9 The pin function is switched as shown below according to the combination of the operating mode, PFCR setting, and bit PB1DDR.

Operating mode	Modes 4 to 6			Mode 7	
AE3 to AE0 in PFCR	B'000x	Other than B'000x		—	
PB1DDR	—	0	1	0	1
Pin function	A9 output	PB1 input	PB1 output	PB1 input	PB1 output

x: Don't care

PB0/A8 The pin function is switched as shown below according to the combination of the operating mode, PFCR setting, and bit PB0DDR.

Operating mode	Modes 4 to 6			Mode 7	
AE3 to AE0 in PFCR	B'0000	Other than B'0000		—	
PB0DDR	—	0	1	0	1
Pin function	A8 output	PB0 input	PB0 output	PB0 input	PB0 output

## 9.7.4 MOS Input Pull-Up Function

Port B has a built-in MOS input pull-up function that can be controlled by software. MOS input pull-up can be specified as on or off for individual bits.

With port input pins, when a PBDDR bit is cleared to 0, setting the corresponding PBPCR bit to 1 turns on the MOS input pull-up for that pin.

The MOS input pull-up function is in the off state after a power-on reset and in hardware standby mode. The previous state is retained in software standby mode.

Table 9.14 summarizes the MOS input pull-up states.

**Table 9.14 MOS Input Pull-Up States (Port B)**

<b>Pins</b>	<b>Power-On Reset</b>	<b>Hardware Standby Mode</b>	<b>Software Standby Mode</b>	<b>In Other Operations</b>
Address output, port output	OFF	OFF	OFF	OFF
Port input	OFF	OFF	ON/OFF	ON/OFF

Legend:

OFF: MOS input pull-up is always off.

ON/OFF: On when PBDDR = 0 and PBPCR = 1; otherwise off.



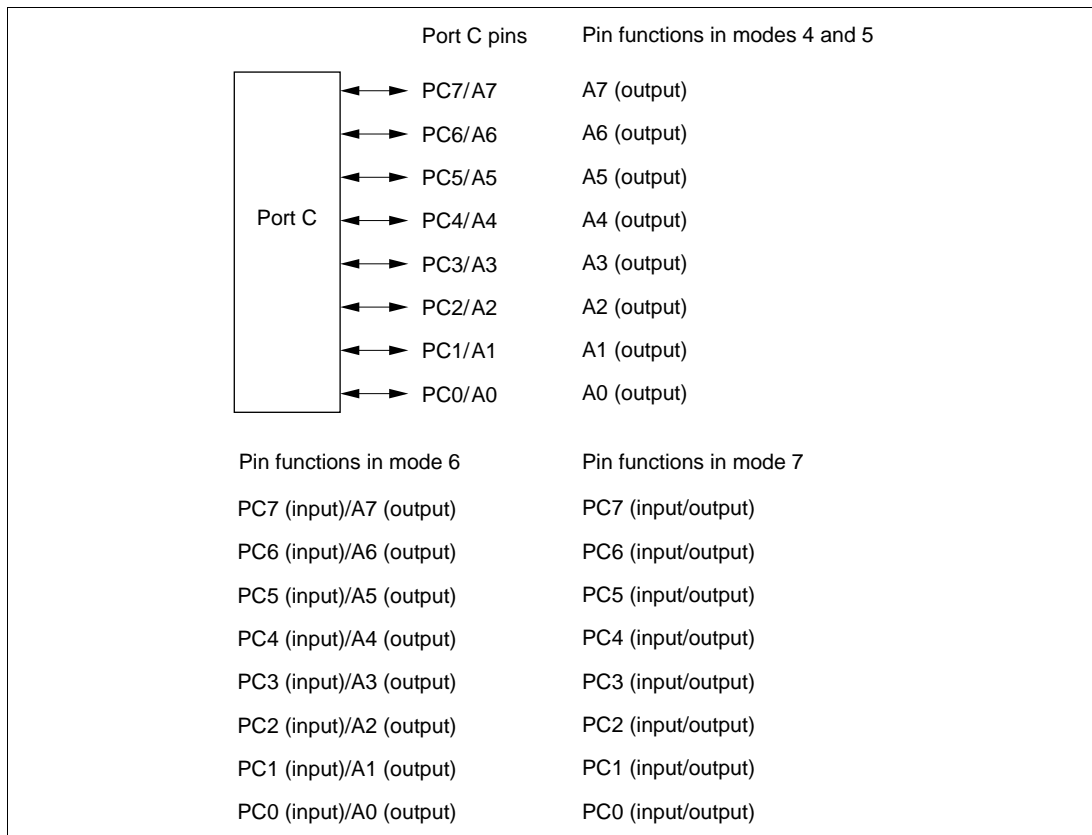
## 9.8 Port C

### 9.8.1 Overview

Port C is an 8-bit I/O port. Port C pins also function as address bus outputs. The pin functions depend on the operating mode.

Port C has a built-in MOS input pull-up function that can be controlled by software.

Figure 9.7 shows the port C pin configuration.



**Figure 9.7 Port C Pin Functions**

## 9.8.2 Register Configuration

Table 9.15 shows the port C register configuration.

**Table 9.15 Port C Registers**

Name	Abbreviation	R/W	Initial Value	Address*
Port C data direction register	PCDDR	W	H'00	H'FE3B
Port C data register	PCDR	R/W	H'00	H'FF0B
Port C register	PORTC	R	Undefined	H'FFBB
Port C MOS pull-up control register	PCPCR	R/W	H'00	H'FE42

Note: \* Lower 16 bits of the address.

### Port C Data Direction Register (PCDDR)

Bit	:	7	6	5	4	3	2	1	0
		PC7DDR	PC6DDR	PC5DDR	PC4DDR	PC3DDR	PC2DDR	PC1DDR	PC0DDR
Initial value	:	0	0	0	0	0	0	0	0
R/W	:	W	W	W	W	W	W	W	W

PCDDR is an 8-bit write-only register, the individual bits of which specify input or output for the pins of port C. PCDDR cannot be read; if it is, an undefined value will be read.

PCDDR is initialized to H'00 by a power-on reset and in hardware standby mode. It retains its previous state in software standby mode. The OPE bit in SBYCR is used to select whether the address output pins retain their output state or become high-impedance when a transition is made to software standby mode.

- Modes 4 and 5  
Port C pins are address outputs regardless of the PCDDR settings.
- Mode 6  
Setting a PCDDR bit to 1 makes the corresponding port C pin an address output, while clearing the bit to 0 makes the pin an input port.
- Mode 7  
Setting a PCDDR bit to 1 makes the corresponding port C pin an output port, while clearing the bit to 0 makes the pin an input port.

### Port C Data Register (PCDR)

Bit	:	7	6	5	4	3	2	1	0
		PC7DR	PC6DR	PC5DR	PC4DR	PC3DR	PC2DR	PC1DR	PC0DR
Initial value	:	0	0	0	0	0	0	0	0
R/W	:	R/W	R/W	R/W	R/W	R/W	R/W	R/W	R/W

PCDR is an 8-bit readable/writable register that stores output data for the port C pins (PC7 to PC0).

PCDR is initialized to H'00 by a power-on reset and in hardware standby mode. It retains its previous state in software standby mode.

### Port C Register (PORTC)

Bit	:	7	6	5	4	3	2	1	0
		PC7	PC6	PC5	PC4	PC3	PC2	PC1	PC0
Initial value	:	—*	—*	—*	—*	—*	—*	—*	—*
R/W	:	R	R	R	R	R	R	R	R

Note: \* Determined by the state of pins PC7 to PC0.

PORTC is an 8-bit read-only register that shows the pin states. It cannot be written to. Writing of output data for the port C pins (PC7 to PC0) must always be performed on PCDR.

If a port C read is performed while PCDDR bits are set to 1, the PCDR values are read. If a port C read is performed while PCDDR bits are cleared to 0, the pin states are read.

After a power-on reset and in hardware standby mode, PORTC contents are determined by the pin states, as PCDDR and PCDR are initialized. PORTC retains its previous state in software standby mode.

### Port C MOS Pull-Up Control Register (PCPCR)

Bit	:	7	6	5	4	3	2	1	0
		PC7PCR	PC6PCR	PC5PCR	PC4PCR	PC3PCR	PC2PCR	PC1PCR	PC0PCR
Initial value	:	0	0	0	0	0	0	0	0
R/W	:	R/W	R/W	R/W	R/W	R/W	R/W	R/W	R/W

PCPCR is an 8-bit readable/writable register that controls the MOS input pull-up function incorporated into port C on a bit-by-bit basis.

PCPCR is valid for port input (modes 6 and 7).

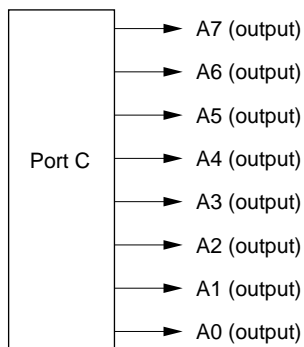
When a PCDDR bit is cleared to 0 (input port setting), setting the corresponding PCPCR bit to 1 turns on the MOS input pull-up for the corresponding pin.

PCPCR is initialized to H'00 by a power-on reset and in hardware standby mode. It retains its previous state in software standby mode.

### 9.8.3 Pin Functions in Each Mode

#### Modes 4 and 5

In modes 4 and 5, port C pins function as address outputs automatically. Port C pin functions in modes 4 and 5 are shown in figure 9.8.

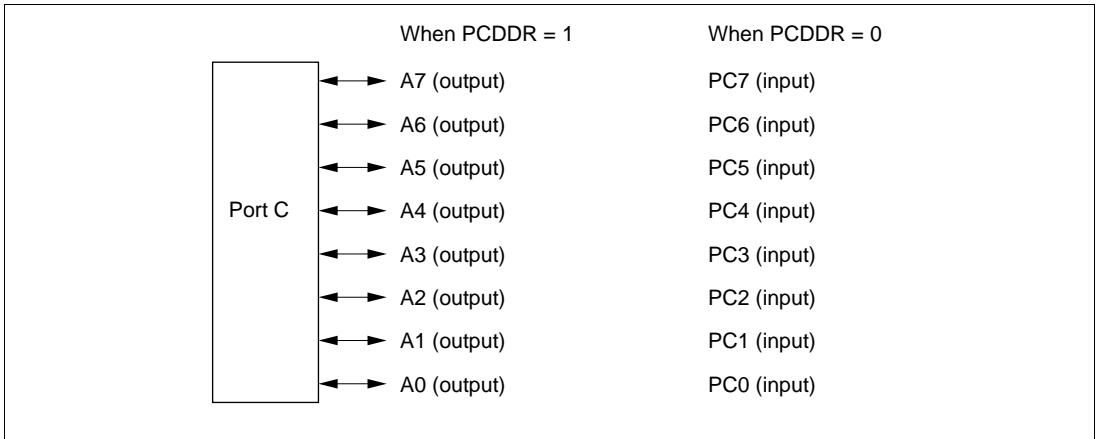


**Figure 9.8 Port C Pin Functions (Modes 4 and 5)**

## Mode 6

In mode 6, port C pins function as address outputs or input ports, and input or output can be specified bit by bit. Setting a PCDDR bit to 1 makes the corresponding port C pin an address output, while clearing the bit to 0 makes the pin an input port.

Port C pin functions in mode 6 are shown in figure 9.9.

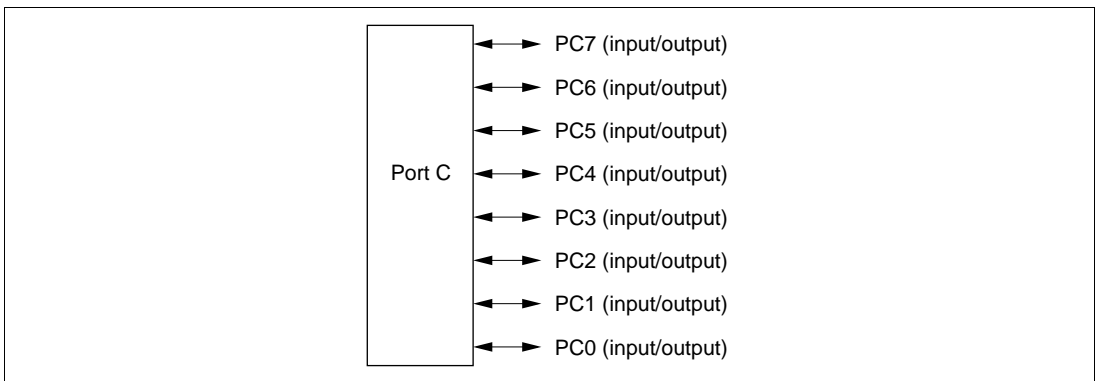


**Figure 9.9 Port C Pin Functions (Mode 6)**

## Mode 7

In mode 7, port C functions as an I/O port, and input or output can be specified bit by bit. Setting a PCDDR bit to 1 makes the corresponding port C pin an output port, while clearing the bit to 0 makes the pin an input port.

Port C pin functions in mode 7 are shown in figure 9.10.



**Figure 9.10 Port C Pin Functions (Mode 7)**

## 9.8.4 MOS Input Pull-Up Function

Port C has a built-in MOS input pull-up function that can be controlled by software. MOS input pull-up can be used in modes 6 and 7, and can be specified as on or off for individual bits.

With the port input pin function (modes 6 and 7), when a PCDDR bit is cleared to 0, setting the corresponding PCPCR bit to 1 turns on the MOS input pull-up for that pin.

The MOS input pull-up function is in the off state after a power-on reset and in hardware standby mode. The previous state is retained in software standby mode.

Table 9.16 summarizes the MOS input pull-up states.

**Table 9.16 MOS Input Pull-Up States (Port C)**

<b>Pins</b>	<b>Power-On Reset</b>	<b>Hardware Standby Mode</b>	<b>Software Standby Mode</b>	<b>In Other Operations</b>
Address output (modes 4 and 5), port output (modes 6 and 7)	OFF	OFF	OFF	OFF
Port input (modes 6 and 7)	OFF	OFF	ON/OFF	ON/OFF

Legend:

OFF: MOS input pull-up is always off.

ON/OFF: On when PCDDR = 0 and PCPCR = 1; otherwise off.

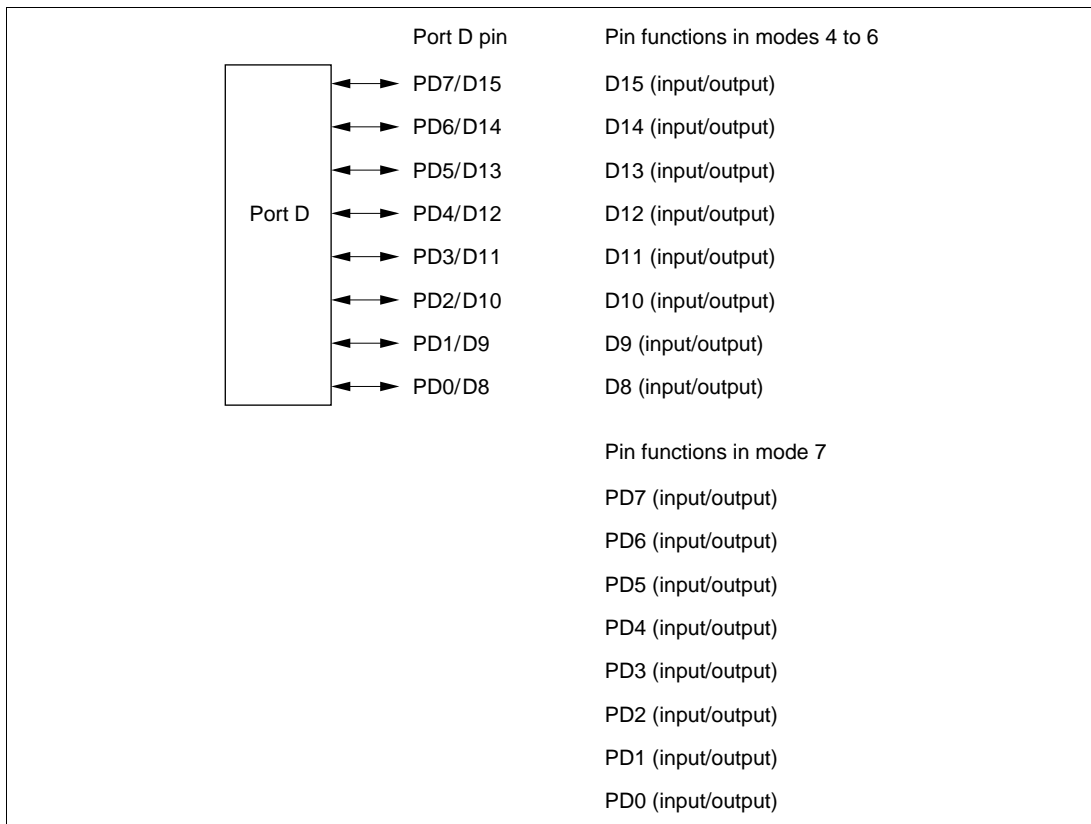
## 9.9 Port D

### 9.9.1 Overview

Port D is an 8-bit I/O port. Port D pins also function as data bus input/output pins. The pin functions depend on the operating mode.

Port D has a built-in MOS input pull-up function that can be controlled by software.

Figure 9.11 shows the port D pin configuration.



**Figure 9.11 Port D Pin Functions**

## 9.9.2 Register Configuration

Table 9.17 shows the port D register configuration.

**Table 9.17 Port D Registers**

Name	Abbreviation	R/W	Initial Value	Address*
Port D data direction register	PDDDR	W	H'00	H'FE3C
Port D data register	PDDR	R/W	H'00	H'FF0C
Port D register	PORTD	R	Undefined	H'FFBC
Port D MOS pull-up control register	PDPCR	R/W	H'00	H'FE43

Note: \* Lower 16 bits of the address.

### Port D Data Direction Register (PDDDR)

Bit	:	7	6	5	4	3	2	1	0
		PD7DDR	PD6DDR	PD5DDR	PD4DDR	PD3DDR	PD2DDR	PD1DDR	PD0DDR
Initial value	:	0	0	0	0	0	0	0	0
R/W	:	W	W	W	W	W	W	W	W

PDDDR is an 8-bit write-only register, the individual bits of which specify input or output for the pins of port D. PDDDR cannot be read; if it is, an undefined value will be read.

PDDDR is initialized to H'00 by a power-on reset and in hardware standby mode. It retains its previous state in software standby mode.

- Modes 4 to 6  
The input/output direction settings in PDDDR are ignored, and port D pins automatically function as data input/output pins.
- Mode 7  
Setting a PDDDR bit to 1 makes the corresponding port D pin an output port, while clearing the bit to 0 makes the pin an input port.



## Port D Data Register (PDDR)

Bit	:	7	6	5	4	3	2	1	0
		PD7DR	PD6DR	PD5DR	PD4DR	PD3DR	PD2DR	PD1DR	PD0DR
Initial value	:	0	0	0	0	0	0	0	0
R/W	:	R/W	R/W	R/W	R/W	R/W	R/W	R/W	R/W

PDDR is an 8-bit readable/writable register that stores output data for the port D pins (PD7 to PD0).

PDDR is initialized to H'00 by a power-on reset and in hardware standby mode. It retains its previous state in software standby mode.

## Port D Register (PORTD)

Bit	:	7	6	5	4	3	2	1	0
		PD7	PD6	PD5	PD4	PD3	PD2	PD1	PD0
Initial value	:	—*	—*	—*	—*	—*	—*	—*	—*
R/W	:	R	R	R	R	R	R	R	R

Note: \* Determined by the state of pins PD7 to PD0.

PORTD is an 8-bit read-only register that shows the pin states. It cannot be written to. Writing of output data for the port D pins (PD7 to PD0) must always be performed on PDDR.

If a port D read is performed while PDDDR bits are set to 1, the PDDR values are read. If a port D read is performed while PDDDR bits are cleared to 0, the pin states are read.

After a power-on reset and in hardware standby mode, PORTD contents are determined by the pin states, as PDDDR and PDDR are initialized. PORTD retains its previous state in software standby mode.

## Port D MOS Pull-Up Control Register (PDPCR)

Bit	:	7	6	5	4	3	2	1	0
		PD7PCR	PD6PCR	PD5PCR	PD4PCR	PD3PCR	PD2PCR	PD1PCR	PD0PCR
Initial value	:	0	0	0	0	0	0	0	0
R/W	:	R/W	R/W	R/W	R/W	R/W	R/W	R/W	R/W

PDPCR is an 8-bit readable/writable register that controls the MOS input pull-up function incorporated into port D on a bit-by-bit basis.

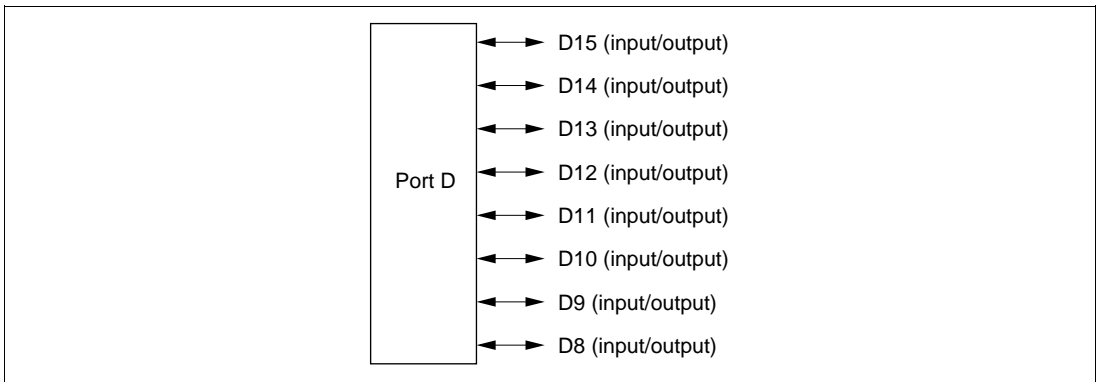
PDPCR is valid for port input pins (mode 7). When a PDDDR bit is cleared to 0 (input port setting), setting the corresponding PDPCR bit to 1 turns on the MOS input pull-up for the corresponding pin.

PDPCR is initialized to H'00 by a power-on reset and in hardware standby mode. It retains its previous state in software standby mode.

### 9.9.3 Pin Functions in Each Mode

#### Modes 4 to 6

In modes 4 to 6, port D pins function as data input/output pins automatically. Port D pin functions in modes 4 to 6 are shown in figure 9.12.

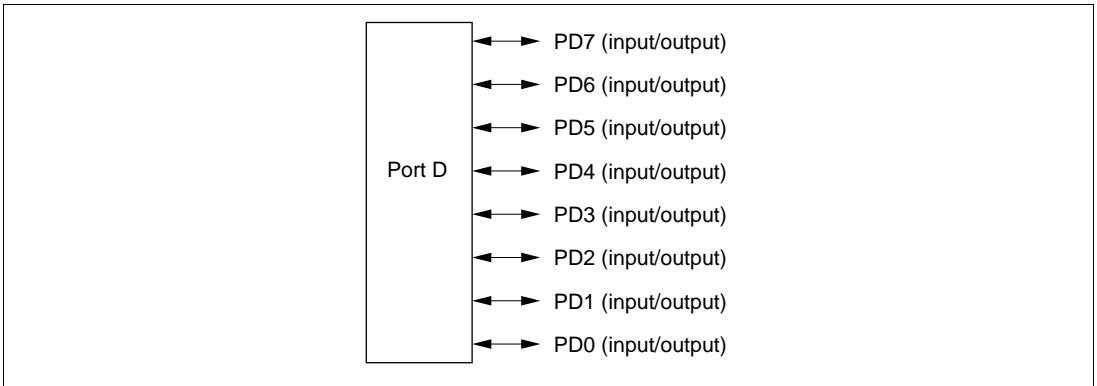


**Figure 9.12 Port D Pin Functions (Modes 4 to 6)**

#### Mode 7

In mode 7, port D functions as an I/O port, and input or output can be specified bit by bit. Setting a PDDDR bit to 1 makes the corresponding port D pin an output port, while clearing the bit to 0 makes the pin an input port.

Port D pin functions in mode 7 are shown in figure 9.13.



**Figure 9.13 Port D Pin Functions (Mode 7)**

### 9.9.4 MOS Input Pull-Up Function

Port D has a built-in MOS input pull-up function that can be controlled by software. MOS input pull-up can be used in mode 7, and can be specified as on or off for individual bits.

With the port input pin function (mode 7), when a PDDDR bit is cleared to 0, setting the corresponding PDPCR bit to 1 turns on the MOS input pull-up for that pin.

The MOS input pull-up function is in the off state after a power-on reset and in hardware standby mode. The previous state is retained in software standby mode.

Table 9.18 summarizes the MOS input pull-up states.

**Table 9.18 MOS Input Pull-Up States (Port D)**

Pins	Power-On Reset	Hardware Standby Mode	Software Standby Mode	In Other Operations
Data input/output (modes 4 to 6), port output (mode 7)	OFF	OFF	OFF	OFF
Port input (mode 7)	OFF	OFF	ON/OFF	ON/OFF

Legend:

OFF: MOS input pull-up is always off.

ON/OFF: On when PDDDR = 0 and PDPCR = 1; otherwise off.

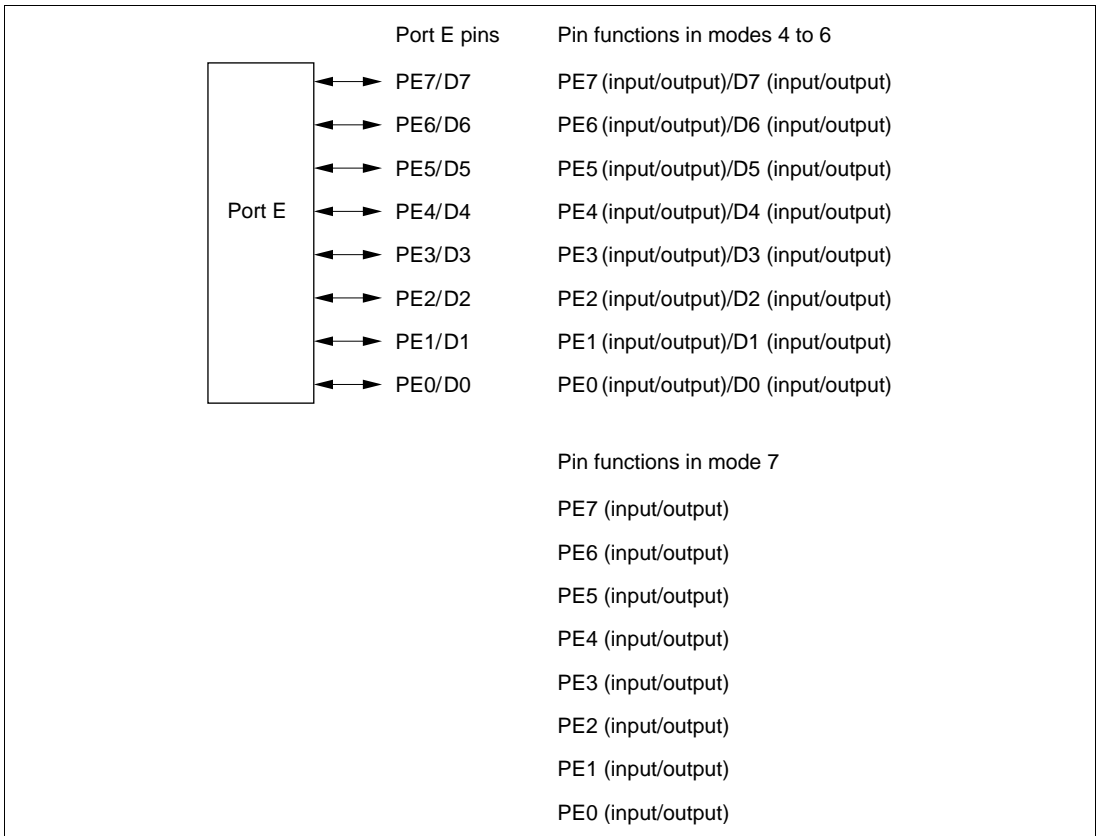
## 9.10 Port E

### 9.10.1 Overview

Port E is an 8-bit I/O port. Port E pins also function as data bus input/output pins. The pin functions depend on the operating mode and on whether 8-bit or 16-bit bus mode is used.

Port E has a built-in MOS input pull-up function that can be controlled by software.

Figure 9.14 shows the port E pin configuration.



**Figure 9.14 Port E Pin Functions**

## 9.10.2 Register Configuration

Table 9.19 shows the port E register configuration.

**Table 9.19 Port E Registers**

Name	Abbreviation	R/W	Initial Value	Address*
Port E data direction register	PEDDR	W	H'00	H'FE3D
Port E data register	PEDR	R/W	H'00	H'FF0D
Port E register	PORTE	R	Undefined	H'FFBD
Port E MOS pull-up control register	PEPCR	R/W	H'00	H'FE44

Note: \* Lower 16 bits of the address.

### Port E Data Direction Register (PEDDR)

Bit	:	7	6	5	4	3	2	1	0
		PE7DDR	PE6DDR	PE5DDR	PE4DDR	PE3DDR	PE2DDR	PE1DDR	PE0DDR
Initial value	:	0	0	0	0	0	0	0	0
R/W	:	W	W	W	W	W	W	W	W

PEDDR is an 8-bit write-only register, the individual bits of which specify input or output for the pins of port E. PEDDR cannot be read; if it is, an undefined value will be read.

PEDDR is initialized to H'00 by a power-on reset and in hardware standby mode. It retains its previous state in software standby mode.

- Modes 4 to 6

When 8-bit bus mode is selected, port E functions as an I/O port. Setting a PEDDR bit to 1 makes the corresponding port E pin an output port, while clearing the bit to 0 makes the pin an input port.

When 16-bit bus mode is selected, the input/output direction settings in PEDDR are ignored, and port E pins automatically function as data input/output pins.

For details of the 8-bit and 16-bit bus modes, see section 7, Bus Controller.

- Mode 7

Setting a PEDDR bit to 1 makes the corresponding port E pin an output port, while clearing the bit to 0 makes the pin an input port.

## Port E Data Register (PEDR)

Bit	:	7	6	5	4	3	2	1	0
		PE7DR	PE6DR	PE5DR	PE4DR	PE3DR	PE2DR	PE1DR	PE0DR
Initial value	:	0	0	0	0	0	0	0	0
R/W	:	R/W	R/W	R/W	R/W	R/W	R/W	R/W	R/W

PEDR is an 8-bit readable/writable register that stores output data for the port E pins (PE7 to PE0).

PEDR is initialized to H'00 by a power-on reset and in hardware standby mode. It retains its previous state in software standby mode.

## Port E Register (PORTE)

Bit	:	7	6	5	4	3	2	1	0
		PE7	PE6	PE5	PE4	PE3	PE2	PE1	PE0
Initial value	:	—*	—*	—*	—*	—*	—*	—*	—*
R/W	:	R	R	R	R	R	R	R	R

Note: \* Determined by the state of pins PE7 to PE0.

PORTE is an 8-bit read-only register that shows the pin states. It cannot be written to. Writing of output data for the port E pins (PE7 to PE0) must always be performed on PEDR.

If a port E read is performed while PEDDR bits are set to 1, the PEDR values are read. If a port E read is performed while PEDDR bits are cleared to 0, the pin states are read.

After a power-on reset and in hardware standby mode, PORTE contents are determined by the pin states, as PEDDR and PEDR are initialized. PORTE retains its previous state in software standby mode.

## Port E MOS Pull-Up Control Register (PEPCR)

Bit	:	7	6	5	4	3	2	1	0
		PE7PCR	PE6PCR	PE5PCR	PE4PCR	PE3PCR	PE2PCR	PE1PCR	PE0PCR
Initial value	:	0	0	0	0	0	0	0	0
R/W	:	R/W	R/W	R/W	R/W	R/W	R/W	R/W	R/W

PEPCR is an 8-bit readable/writable register that controls the MOS input pull-up function incorporated into port E on a bit-by-bit basis.

PEPCR is valid for port input pins (modes 4 to 6 in 8-bit bus mode, or mode 7).

When a PEDDR bit is cleared to 0 (input port setting), setting the corresponding PEPCR bit to 1 turns on the MOS input pull-up for the corresponding pin.

PEPCR is initialized to H'00 by a power-on reset and in hardware standby mode. It retains its previous state in software standby mode.

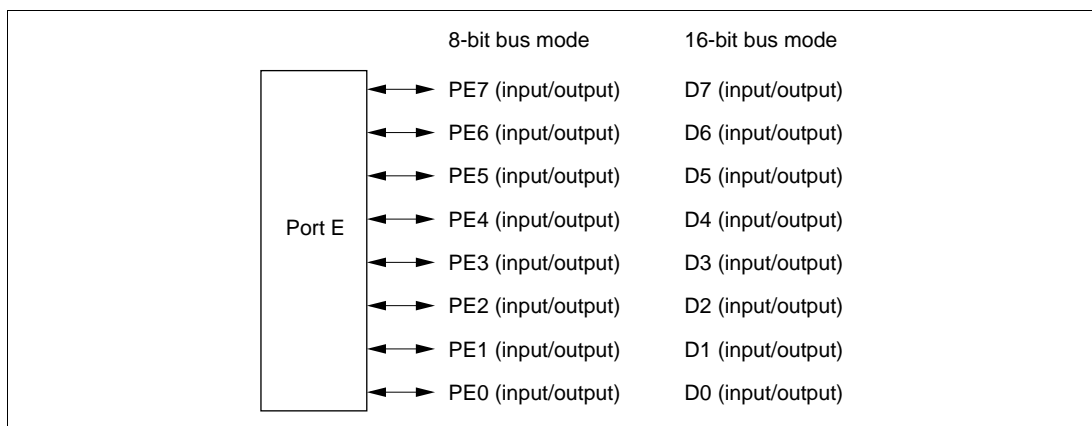
### 9.10.3 Pin Functions in Each Mode

#### Modes 4 to 6

In modes 4 to 6, if 8-bit access space is designated and 8-bit bus mode is selected, port E functions as an I/O port. Setting a PEDDR bit to 1 makes the corresponding port E pin an output port, while clearing the bit to 0 makes the pin an input port.

When 16-bit bus mode is selected, the input/output direction settings in PEDDR are ignored, and port E pins function as data input/output pins.

Port E pin functions in modes 4 to 6 are shown in figure 9.15.

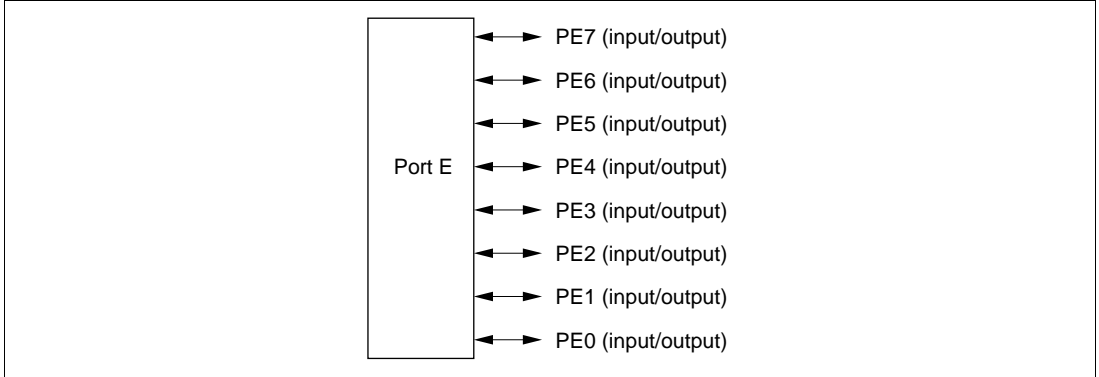


**Figure 9.15 Port E Pin Functions (Modes 4 to 6)**

## Mode 7

In mode 7, port E functions as an I/O port, and input or output can be specified bit by bit. Setting a PEDDR bit to 1 makes the corresponding port E pin an output port, while clearing the bit to 0 makes the pin an input port.

Port E pin functions in mode 7 are shown in figure 9.16.



**Figure 9.16 Port E Pin Functions (Mode 7)**

### 9.10.4 MOS Input Pull-Up Function

Port E has a built-in MOS input pull-up function that can be controlled by software. MOS input pull-up can be used in modes 4 to 6 in 8-bit bus mode, or in mode 7, and can be specified as on or off for individual bits.

With the port input pin function (modes 4 to 6 in 8-bit bus mode, or mode 7), when a PEDDR bit is cleared to 0, setting the corresponding PEPCR bit to 1 turns on the MOS input pull-up for that pin.

The MOS input pull-up function is in the off state after a power-on reset and in hardware standby mode. The previous state is retained in software standby mode.

Table 9.20 summarizes the MOS input pull-up states.



**Table 9.20 MOS Input Pull-Up States (Port E)**

<b>Pins</b>	<b>Power-On Reset</b>	<b>Hardware Standby Mode</b>	<b>Software Standby Mode</b>	<b>In Other Operations</b>
Data input/output (modes 4 to 6 with 16-bit bus), port output (modes 4 to 6 with 8-bit bus, mode 7)	OFF	OFF	OFF	OFF
Port input (modes 4 to 6 with 8-bit bus, mode 7)	OFF	OFF	ON/OFF	ON/OFF

Legend:

OFF: MOS input pull-up is always off.

ON/OFF: On when PEDDR = 0 and PEPCR = 1; otherwise off.

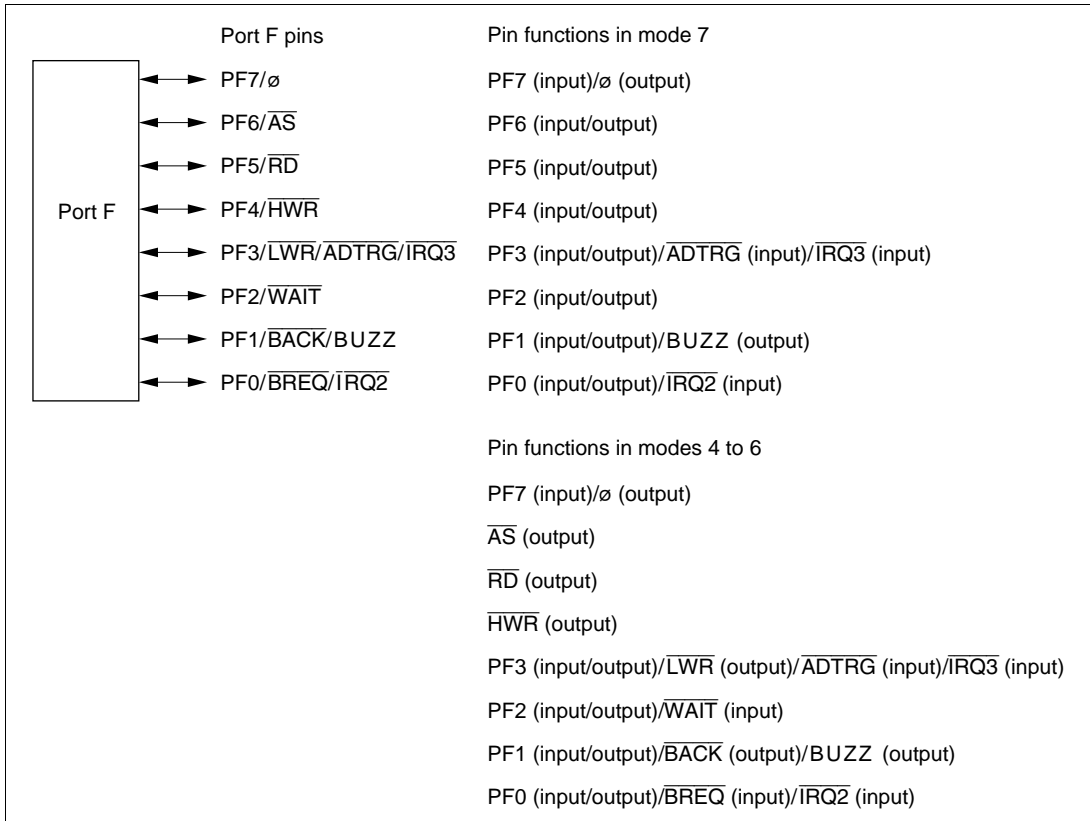
## 9.11 Port F

### 9.11.1 Overview

Port F is an 8-bit I/O port. Port F pins also function as external interrupt input pins ( $\overline{\text{IRQ2}}$  and  $\overline{\text{IRQ3}}$ ), the BUZZ output pin, the A/D trigger input pin ( $\overline{\text{ADTRG}}$ ), bus control signal I/O pins ( $\overline{\text{AS}}$ ,  $\overline{\text{RD}}$ ,  $\overline{\text{HWR}}$ ,  $\overline{\text{LWR}}$ ,  $\overline{\text{WAIT}}$ ,  $\overline{\text{BREQ}}$ , and  $\overline{\text{BACK}}$ ), and the system clock ( $\emptyset$ ) output pin.

The interrupt input pins ( $\overline{\text{IRQ2}}$  and  $\overline{\text{IRQ3}}$ ) are Schmitt-triggered inputs.

Figure 9.17 shows the port F pin configuration.



**Figure 9.17 Port F Pin Functions**

### 9.11.2 Register Configuration

Table 9.21 shows the port F register configuration.

**Table 9.21 Port F Registers**

Name	Abbreviation	R/W	Initial Value	Address* <sup>1</sup>
Port F data direction register	PFDDR	W	H'80/H'00* <sup>2</sup>	H'FE3E
Port F data register	PFDR	R/W	H'00	H'FF0E
Port F register	PORTF	R	Undefined	H'FFBE

Notes: \*1 Lower 16 bits of the address.

\*2 Initial value depends on the mode.

PFDDR is initialized to H'80 in modes 4 to 6, and to H'00 in mode 7.

## Port F Data Direction Register (PFDDR)

Bit	7	6	5	4	3	2	1	0
	PF7DDR	PF6DDR	PF5DDR	PF4DDR	PF3DDR	PF2DDR	PF1DDR	PF0DDR
Modes 4 to 6								
Initial value :	1	0	0	0	0	0	0	0
R/W :	W	W	W	W	W	W	W	W
Mode 7								
Initial value :	0	0	0	0	0	0	0	0
R/W :	W	W	W	W	W	W	W	W

PFDDR is an 8-bit write-only register, the individual bits of which specify input or output for the pins of port F. PFDDR cannot be read; if it is, an undefined value will be read.

PFDDR is initialized to H'80 (modes 4 to 6) or H'00 (mode 7) by a power-on reset and in hardware standby mode. It retains its previous state in software standby mode. The OPE bit in SBYCR is used to select whether the bus control output pins retain their output state or become high-impedance when a transition is made to software standby mode.

- Modes 4 to 6

Pin PF7 functions as the  $\emptyset$  output pin when the corresponding PFDDR bit is set to 1, and as an input port when the bit is cleared to 0.

The input/output direction specification in PFDDR is ignored for pins PF6 to PF4, which are automatically designated as bus control outputs ( $\overline{AS}$ ,  $\overline{RD}$ , and  $\overline{HWR}$ ).

When 8-bit bus mode selected, pin PF3 is made bus control output ( $\overline{LWR}$ ). When 16-bit bus mode selected, setting a PF3DDR bit to 1 makes the pin an output port, while clearing the bit to 0 makes the pin an input port.

Pins PF2 to PF0 are made bus control input/output pins ( $\overline{WAIT}$ ,  $\overline{BACK}$ , and  $\overline{BREQ}$ ) by bus controller settings. Otherwise, setting a PFDDR bit to 1 makes the corresponding pin an output port, while clearing the bit to 0 makes the pin an input port.

- Mode 7

Setting a PFDDR bit to 1 makes the corresponding port F pin PF6 to PF0 an output port, or in the case of pin PF7, the  $\emptyset$  output pin. Clearing the bit to 0 makes the pin an input port.

## Port F Data Register (PFDR)

Bit	:	7	6	5	4	3	2	1	0
		PF7DR	PF6DR	PF5DR	PF4DR	PF3DR	PF2DR	PF1DR	PF0DR
Initial value	:	0	0	0	0	0	0	0	0
R/W	:	R/W	R/W	R/W	R/W	R/W	R/W	R/W	R/W

PFDR is an 8-bit readable/writable register that stores output data for the port F pins (PF7 to PF0).

PFDR is initialized to H'00 by a power-on reset and in hardware standby mode. It retains its previous state in software standby mode.

## Port F Register (PORTF)

Bit	:	7	6	5	4	3	2	1	0
		PF7	PF6	PF5	PF4	PF3	PF2	PF1	PF0
Initial value	:	—*	—*	—*	—*	—*	—*	—*	—*
R/W	:	R	R	R	R	R	R	R	R

Note: \* Determined by the state of pins PF7 to PF0.

PORTF is an 8-bit read-only register that shows the pin states. It cannot be written to. Writing of output data for the port F pins (PF7 to PF0) must always be performed on PFDR.

If a port F read is performed while PFDDR bits are set to 1, the PFDR values are read. If a port F read is performed while PFDDR bits are cleared to 0, the pin states are read.

After a power-on reset and in hardware standby mode, PORTF contents are determined by the pin states, as PFDDR and PFDR are initialized. PORTF retains its previous state in software standby mode.

### 9.11.3 Pin Functions

Port F pins also function as external interrupt input pins ( $\overline{\text{IRQ2}}$  and  $\overline{\text{IRQ3}}$ ), the BUZZ output pin, the A/D trigger input pin (ADTRG), bus control signal I/O pins (AS, RD, HWR, LWR, WAIT,  $\overline{\text{BREQ}}$ , and  $\overline{\text{BACK}}$ ), and the system clock ( $\phi$ ) output pin. The pin functions differ between modes 4 to 6 and mode 7. Port F pin functions are shown in table 9.22.

**Table 9.22 Port F Pin Functions**
**Pin Pin Functions and Selection Method**

PF7/ $\emptyset$  The pin function is switched as shown below according to bit PF7DDR.

PF7DDR	0	1
Pin function	PF7 input	$\emptyset$ output

PF6/ $\overline{AS}$  The pin function is switched as shown below according to the operating mode and bit PF6DDR.

Operating mode	Modes 4 to 6	Mode 7	
PF6DDR	—	0	1
Pin function	$\overline{AS}$ output	PF6 input	PF6 output

PF5/ $\overline{RD}$  The pin function is switched as shown below according to the operating mode and bit PF5DDR.

Operating mode	Modes 4 to 6	Mode 7	
PF5DDR	—	0	1
Pin function	$\overline{RD}$ output	PF5 input	PF5 output

PF4/ $\overline{HWR}$  The pin function is switched as shown below according to the operating mode and bit PF4DDR.

Operating mode	Modes 4 to 6	Mode 7	
PF4DDR	—	0	1
Pin function	$\overline{HWR}$ output	PF4 input	PF4 output

PF3/ $\overline{LWR}$ /  
 $\overline{ADTRG}$ /  
IRQ3 The pin function is switched as shown below according to the operating mode, the bus mode, A/D converter bits TRGS1 and TRGS0, and bit PF3DDR.

Operating mode	Modes 4 to 6		Mode 7		
Bus mode	16-bit bus mode	8-bit bus mode		—	
PF3DDR	—	0	1	0	1
Pin function	$\overline{LWR}$ output	PF3 input	PF3 output	PF3 input	PF3 output
		$\overline{ADTRG}$ input* <sup>1</sup>			
		$\overline{IRQ3}$ input* <sup>2</sup>			

Notes: \*1  $\overline{ADTRG}$  input when TRGS0 = TRGS1 = 1.

\*2 When used as an external interrupt input pin, do not use as an I/O pin for another function.

## Pin Pin Functions and Selection Method

PF2/ $\overline{\text{WAIT}}$  The pin function is switched as shown below according to the operating mode, bit WAITE in BCRL, and bit PF2DDR.

Operating mode	Modes 4 to 6			Mode 7	
WAITE	0		1	—	
PF2DDR	0	1	—	0	1
Pin function	PF2 input	PF2 output	$\overline{\text{WAIT}}$ input	PF2 input	PF2 output

PF1/ $\overline{\text{BACK}}$ /  
BUZZ The pin function is switched as shown below according to the operating mode, bit BRLE in BCRL, bit BUZZE in PFCR, and bit PF1DDR.

Operating mode	Modes 4 to 6				Mode 7		
BRLE	0			1	—		
BUZZE	0		1	—	0		1
PF1DDR	0	1	—	—	0	1	—
Pin function	PF1 input	PF1 output	BUZZ output	$\overline{\text{BACK}}$ output	PF1 input	PF1 output	BUZZ output

PF0/ $\overline{\text{BREQ}}$ /  
 $\overline{\text{IRQ2}}$  The pin function is switched as shown below according to the operating mode, bit BRLE in BCRL, and bit PF0DDR.

Operating mode	Modes 4 to 6			Mode 7	
BRLE	0		1	—	
PF0DDR	0	1	—	0	1
Pin function	PF0 input	PF0 output	$\overline{\text{BREQ}}$ input	PF0 input	PF0 output
	$\overline{\text{IRQ2}}$ input*				

Note: \* When used as an external interrupt input pin, do not use as an I/O pin for another function.

## 9.12 Port G\*

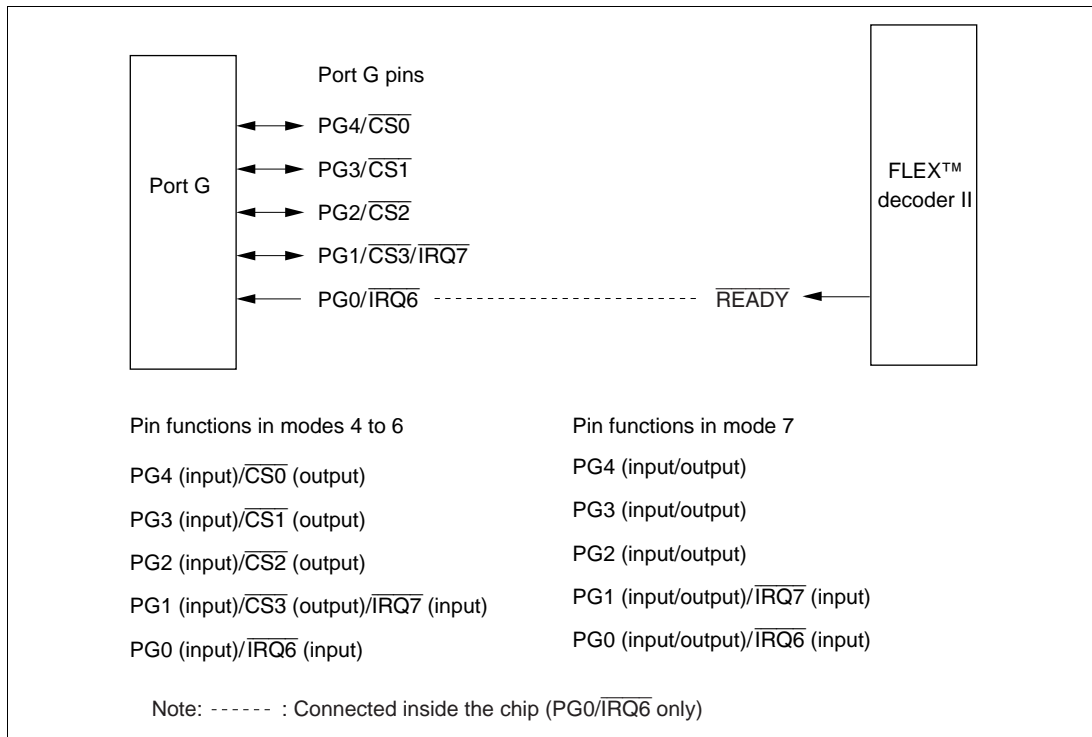
Note: \* PG0/ $\overline{\text{IRQ6}}$ , only is a internal input port.

### 9.12.1 Overview

Port G consists of a 4-bit I/O port and on-chip 1-bit input port that is a dedicated port for the FLEX™ decoder II interface. Port G pins also function as external interrupt input pins ( $\overline{\text{IRQ6}}$  (dedicated to the interrupt from the FLEX™ decoder II) and  $\overline{\text{IRQ7}}$ ) and bus control signal output pins (CS0 to CS3).

The interrupt input pin ( $\overline{\text{IRQ7}}$ ) is Schmitt-triggered input.

Figure 9.18 shows the port G pin configuration.



**Figure 9.18 Port G Pin Functions**

### 9.12.2 Register Configuration

Table 9.23 shows the port G register configuration.

**Table 9.23 Port G Registers**

Name	Abbreviation	R/W	Initial Value* <sup>2</sup>	Address* <sup>1</sup>
Port G data direction register	PGDDR	W	H'10/H'00* <sup>3</sup>	H'FE3F
Port G data register	PGDR	R/W	H'00	H'FF0F
Port G register	PORTG	R	Undefined	H'FFBF

Notes: \*<sup>1</sup> Lower 16 bits of the address.

\*<sup>2</sup> Value of bits 4 to 0.

\*<sup>3</sup> Initial value depends on the mode.

PGDDR is initialized to H'10 in modes 4 and 5, and to H'00 in modes 6 and 7.

## Port G Data Direction Register (PGDDR)

Bit	:	7	6	5	4	3	2	1	0
		—	—	—	PG4DDR	PG3DDR	PG2DDR	PG1DDR	—

### Modes 4 and 5

Initial value	:	Undefined	Undefined	Undefined	1	0	0	0	Undefined
R/W	:	—	—	—	W	W	W	W	W

### Modes 6 and 7

Initial value	:	Undefined	Undefined	Undefined	0	0	0	0	Undefined
R/W	:	—	—	—	W	W	W	W	W

PGDDR is an 8-bit write-only register, the individual bits of which specify input or output for the pins of port G. PGDDR cannot be read. Also, bits 7 to 5 are reserved, and cannot be modified. Bit 0 is reserved, and should always be written with 0.

Bit PG4DDR is initialized to 1 (modes 4 and 5) or 0 (modes 6 and 7) by a power-on reset and in hardware standby mode. PGDDR retains its previous state in software standby mode. The OPE bit in SBYCR is used to select whether the bus control output pins retain their output state or become high-impedance when a transition is made to software standby mode.

- Modes 4 to 6

Pins PG4 to PG1 function as bus control signal output pins ( $\overline{CS0}$  to  $\overline{CS3}$ ) when the corresponding PGDDR bits are set to 1, and as input ports when the bits are cleared to 0.

Pin PG0 functions as an output port when the corresponding PGDDR bit is set to 1, and as an input port when the bit is cleared to 0.

- Mode 7

Setting a PGDDR bit to 1 makes the corresponding pin an output port, while clearing the bit to 0 makes the pin an input port.

## Port G Data Register (PGDR)

Bit	:	7	6	5	4	3	2	1	0
		—	—	—	PG4DR	PG3DR	PG2DR	PG1DR	—

Initial value	:	Undefined	Undefined	Undefined	0	0	0	0	Undefined
R/W	:	—	—	—	R/W	R/W	R/W	R/W	R/W

PGDR is an 8-bit readable/writable register that stores output data for the port G pins (PG4 to PG1).

Bits 7 to 5 are reserved; these bits cannot be modified and will return an undefined value if read.



Bit 0 is reserved: this bit should always be written with 0 and will return an undefined value if read.

PGDR is initialized to H'00 (bits 4 to 0) by a power-on reset and in hardware standby mode. It retains its previous state in software standby mode.

### Port G Register (PORTG)

Bit	:	7	6	5	4	3	2	1	0
		—	—	—	PG4	PG3	PG2	PG1	PG0
Initial value	:	Undefined	Undefined	Undefined	—*	—*	—*	—*	—*
R/W	:	—	—	—	R	R	R	R	R

Note: \* Determined by the state of pins PG4 to PG1, and of  $\overline{\text{READY}}$  of FLEX™ decoder II.

PORTG is an 8-bit read-only register that shows the pin states and  $\overline{\text{READY}}$  of FLEX™ decoder II. It cannot be written to. Writing of output data for the port G pins (PG4 to PG1) must always be performed on PGDR.

Bits 7 to 5 are reserved; these bits will return an undefined value if read.

If a port G read is performed while PGDDR bits are set to 1, the PGDR values are read. If a port G read is performed while PGDDR bits are cleared to 0, the pin states are read.

Note that the  $\overline{\text{READY}}$  state of the FLEX™ decoder II is always read for PG0.

After a power-on reset and in hardware standby mode, PORTG contents are determined by the pin states, as PGDDR and PGDR are initialized. PORTG retains its previous state in software standby mode.

### 9.12.3 Pin Functions

Port G pins also function as external interrupt input pins ( $\overline{\text{IRQ6}}$  dedicated to the interrupt from the FLEX™ decoder II and  $\overline{\text{IRQ7}}$ ) and bus control signal output pins ( $\overline{\text{CS0}}$  to  $\overline{\text{CS3}}$ ). The pin functions differ between modes 4 to 6 and mode 7. Port G pin functions are shown in table 9.24.

**Table 9.24 Port G Pin Functions**

**Pin Pin Functions and Selection Method**

**PG4/ $\overline{CS0}$**  The pin function is switched as shown below according to the operating mode and bit PG4DDR.

Operating mode	Modes 4 to 6		Mode 7	
PG4DDR	0	1	0	1
Pin function	PG4 input	$\overline{CS0}$ output	PG4 input	PG4 output

**PG3/ $\overline{CS1}$**  The pin function is switched as shown below according to the operating mode and bit PG3DDR.

Operating mode	Modes 4 to 6		Mode 7	
PG3DDR	0	1	0	1
Pin function	PG3 input	$\overline{CS1}$ output	PG3 input	PG3 output

**PG2/ $\overline{CS2}$**  The pin function is switched as shown below according to the operating mode and bit PG2DDR.

Operating mode	Modes 4 to 6		Mode 7	
PG2DDR	0	1	0	1
Pin function	PG2 input	$\overline{CS2}$ output	PG2 input	PG2 output

**PG1/ $\overline{CS3}$ /  
IRQ7** The pin function is switched as shown below according to the operating mode and bit PG1DDR.

Operating mode	Modes 4 to 6		Mode 7	
PG1DDR	0	1	0	1
Pin function	PG1 input	$\overline{CS3}$ output	PG1 input	PG1 output
	$\overline{IRQ7}$ input*			

Note: \* When used as an external interrupt input pin, do not use as an I/O pin for another function.

**PG0/ $\overline{IRQ6}$**  PG0 is an input-only pin and can be used as the PG0 or  $\overline{IRQ6}$  input pin. When used as an external interrupt pin ( $\overline{IRQ6}$ ), do not use it as an input pin for another function.  
dedicated I/O port for the FLEX™ decoder II interface)

# Section 10 16-Bit Timer Pulse Unit (TPU)

## 10.1 Overview

The LSI has an on-chip 16-bit timer pulse unit (TPU) that comprises three 16-bit timer channels.

### 10.1.1 Features

- Maximum 6-pulse input/output capability
  - A total of 8 timer general registers (TGRs) are provided (four for channel 0 and two each for channels 1 and 2), each of which can be set independently as an output compare/input capture register
  - TGRC and TGRD for channel 0 can also be used as buffer registers
- Selection of one of six clocks as the counter input for channel 0, and one of seven clocks for channels 1 and 2
- The following operations can be set for each channel:
  - Waveform output at compare match: Selection of 0, 1, or toggle output
  - Input capture function: Selection of rising edge, falling edge, or both edge detection
  - Counter clear operation: Counter clearing possible by compare match or input capture
  - Synchronous operation: Multiple timer counters (TCNT) can be written to simultaneously
    - Simultaneous clearing by compare match and input capture possible
    - Register simultaneous input/output possible by counter synchronous operation
  - PWM mode: Any PWM output duty can be set
    - Maximum of 6-phase PWM output possible by combination with synchronous operation
- Buffer operation settable for channel 0
  - Input capture register double-buffering possible
  - Automatic rewriting of output compare register possible
- Phase counting mode settable for channel 1
  - Two-phase encoder pulse up/down-count possible
- Fast access via internal 16-bit bus
  - Fast access is possible via a 16-bit bus interface

- 13 interrupt sources
  - For channel 0, four compare match/input capture dual-function interrupts and one overflow interrupt can be requested independently
  - For channels 1 and 2, one compare match/input capture dual-function interrupt one compare match interrupt, one overflow interrupt, and one underflow interrupt can be requested independently
- Automatic transfer of register data
  - Block transfer, 1-word data transfer, and 1-byte data transfer possible by data transfer controller (DTC) activation
- A/D converter conversion start trigger can be generated
  - Channel 0 to 2 compare match A/input capture A signals can be used as A/D converter conversion start trigger
- Module stop mode can be set
  - As the initial setting, TPU operation is halted. Register access is enabled by exiting module stop mode.

Table 10.1 lists the functions of the TPU.

**Table 10.1 TPU Functions**

Item	Channel 0	Channel 1	Channel 2	
Count clock	ø/1	ø/1	ø/1	
	ø/4	ø/4	ø/4	
	ø/16	ø/16	ø/16	
	ø/64	ø/64	ø/64	
	TCLKA	ø/256	ø/1024	
	TCLKB	TCLKA	TCLKA	
		TCLKB	TCLKB	
General registers	TGR0A	TGR1A	TGR2A	
	TGR0B	TGR1B	TGR2B	
General registers/ buffer registers	TGR0C	—	—	
	TGR0D			
I/O pins	TIOCA0	TIOCA1	TIOCA2	
	TIOCB0			
	TIOCC0			
	TIOCDO			
Counter clear function	TGR compare match or input capture	TGR compare match or TGR1A input capture	TGR compare match or TGR2A input capture	
Compare match output	0 output	○	○	○
	1 output	○	○	○
	Toggle output	○	○	○
Input capture function	○	○	○	
Synchronous operation	○	○	○	
PWM mode	○	○	○	
Phase counting mode	—	○	—	
Buffer operation	○	—	—	
DTC activation	TGR compare match or input capture	TGR compare match or TGR1A input capture	TGR compare match or TGR2A input capture	
A/D converter trigger	TGR0A compare match or input capture	TGR1A compare match or input capture	TGR2A compare match or input capture	

**Legend**

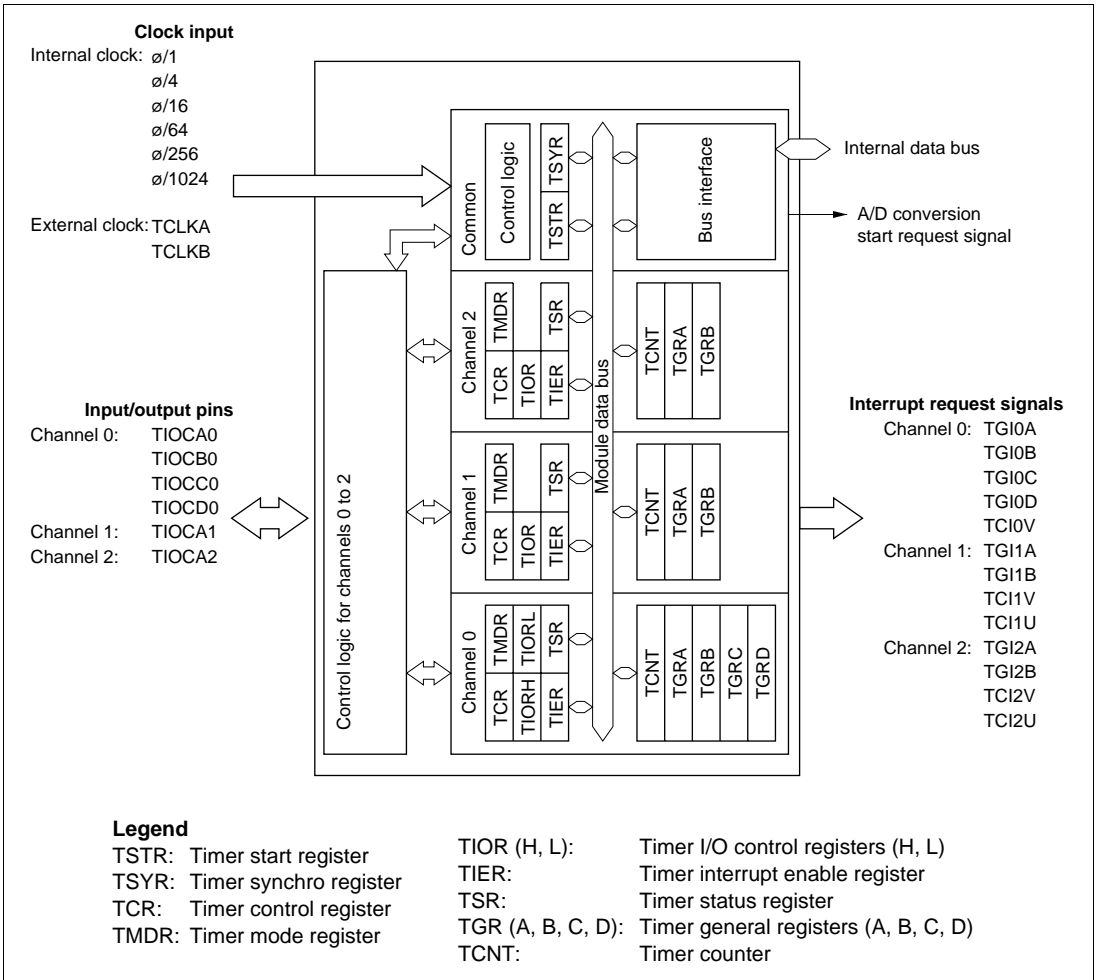
○ : Possible

— : Not possible

<b>Item</b>	<b>Channel 0</b>	<b>Channel 1</b>	<b>Channel 2</b>
Interrupt sources	5 sources <ul style="list-style-type: none"> <li>• Compare match or input capture 0A</li> <li>• Compare match or input capture 0B</li> <li>• Compare match or input capture 0C</li> <li>• Compare match or input capture 0D</li> <li>• Overflow</li> </ul>	4 sources <ul style="list-style-type: none"> <li>• Compare match or input capture 1A</li> <li>• Compare match 1B</li> <li>• Overflow</li> <li>• Underflow</li> </ul>	4 sources <ul style="list-style-type: none"> <li>• Compare match or input capture 2A</li> <li>• Compare match 1B</li> <li>• Overflow</li> <li>• Underflow</li> </ul>

## 10.1.2 Block Diagram

Figure 10.1 shows a block diagram of the TPU.



**Figure 10.1 Block Diagram of TPU**

### 10.1.3 Pin Configuration

Table 10.2 summarizes the TPU pins.

**Table 10.2 TPU Pins**

<b>Channel</b>	<b>Name</b>	<b>Symbol</b>	<b>I/O</b>	<b>Function</b>
All	Clock input A	TCLKA	Input	External clock A input pin (Channel 1 phase counting mode A phase input)
	Clock input B	TCLKB	Input	External clock B input pin (Channel 1 phase counting mode B phase input)
0	Input capture/out compare match A0	TIOCA0	I/O	TGR0A input capture input/output compare output/PWM output pin
	Input capture/out compare match B0	TIOCB0	I/O	TGR0B input capture input/output compare output/PWM output pin
	Input capture/out compare match C0	TIOCC0	I/O	TGR0C input capture input/output compare output/PWM output pin
	Input capture/out compare match D0	TIOCD0	I/O	TGR0D input capture input/output compare output/PWM output pin
1	Input capture/out compare match A1	TIOCA1	I/O	TGR1A input capture input/output compare output/PWM output pin
2	Input capture/out compare match A2	TIOCA2	I/O	TGR2A input capture input/output compare output/PWM output pin



## 10.1.4 Register Configuration

Table 10.3 summarizes the TPU registers.

**Table 10.3 TPU Registers**

Channel	Name	Abbreviation	R/W	Initial Value	Address* <sup>1</sup>
0	Timer control register 0	TCR0	R/W	H'00	H'FF10
	Timer mode register 0	TMDR0	R/W	H'C0	H'FF11
	Timer I/O control register 0H	TIOR0H	R/W	H'00	H'FF12
	Timer I/O control register 0L	TIOR0L	R/W	H'00	H'FF13
	Timer interrupt enable register 0	TIER0	R/W	H'40	H'FF14
	Timer status register 0	TSR0	R/(W)* <sup>2</sup>	H'C0	H'FF15
	Timer counter 0	TCNT0	R/W	H'0000	H'FF16
	Timer general register 0A	TGR0A	R/W	H'FFFF	H'FF18
	Timer general register 0B	TGR0B	R/W	H'FFFF	H'FF1A
	Timer general register 0C	TGR0C	R/W	H'FFFF	H'FF1C
	Timer general register 0D	TGR0D	R/W	H'FFFF	H'FF1E
1	Timer control register 1	TCR1	R/W	H'00	H'FF20
	Timer mode register 1	TMDR1	R/W	H'C0	H'FF21
	Timer I/O control register 1	TIOR1	R/W	H'00	H'FF22
	Timer interrupt enable register 1	TIER1	R/W	H'40	H'FF24
	Timer status register 1	TSR1	R/(W)* <sup>2</sup>	H'C0	H'FF25
	Timer counter 1	TCNT1	R/W	H'0000	H'FF26
	Timer general register 1A	TGR1A	R/W	H'FFFF	H'FF28
	Timer general register 1B	TGR1B	R/W	H'FFFF	H'FF2A
2	Timer control register 2	TCR2	R/W	H'00	H'FF30
	Timer mode register 2	TMDR2	R/W	H'C0	H'FF31
	Timer I/O control register 2	TIOR2	R/W	H'00	H'FF32
	Timer interrupt enable register 2	TIER2	R/W	H'40	H'FF34
	Timer status register 2	TSR2	R/(W)* <sup>2</sup>	H'C0	H'FF35
	Timer counter 2	TCNT2	R/W	H'0000	H'FF36
	Timer general register 2A	TGR2A	R/W	H'FFFF	H'FF38
	Timer general register 2B	TGR2B	R/W	H'FFFF	H'FF3A

Channel	Name	Abbreviation	R/W	Initial Value	Address*1
All	Timer start register	TSTR	R/W	H'00	H'FEB0
	Timer synchro register	TSYR	R/W	H'00	H'FEB1
	Module stop control register A	MSTPCRA	R/W	H'3F	H'FDE8

Notes: \*1 Lower 16 bits of the address.

\*2 Can only be written with 0 for flag clearing.

## 10.2 Register Descriptions

### 10.2.1 Timer Control Register (TCR)

#### Channel 0: TCR0

Bit	:	7	6	5	4	3	2	1	0
		CCLR2	CCLR1	CCLR0	CKEG1	CKEG0	TPSC2	TPSC1	TPSC0
Initial value	:	0	0	0	0	0	0	0	0
R/W	:	R/W	R/W	R/W	R/W	R/W	R/W	R/W	R/W

#### Channel 1: TCR1

#### Channel 2: TCR2

Bit	:	7	6	5	4	3	2	1	0
		—	CCLR1	CCLR0	CKEG1	CKEG0	TPSC2	TPSC1	TPSC0
Initial value	:	0	0	0	0	0	0	0	0
R/W	:	—	R/W	R/W	R/W	R/W	R/W	R/W	R/W

The TCR registers are 8-bit registers that control the TCNT channels. The TPU has three TCR registers, one for each of channels 0 to 2. The TCR registers are initialized to H'00 by a reset, and in hardware standby mode.

**Bits 7 to 5—Counter Clear 2 to 0 (CCLR2 to CCLR0):** These bits select the TCNT counter clearing source.

Channel	Bit 7	Bit 6	Bit 5	Description
	CCLR2	CCLR1	CCLR0	
0	0	0	0	TCNT clearing disabled (Initial value)
			1	TCNT cleared by TGRA compare match/input capture
		1	0	TCNT cleared by TGRB compare match/input capture
			1	TCNT cleared by counter clearing for another channel performing synchronous clearing/synchronous operation* <sup>1</sup>
	1	0	0	TCNT clearing disabled
			1	TCNT cleared by TGRC compare match/input capture* <sup>2</sup>
		1	0	TCNT cleared by TGRD compare match/input capture* <sup>2</sup>
			1	TCNT cleared by counter clearing for another channel performing synchronous clearing/synchronous operation* <sup>1</sup>

Channel	Bit 7	Bit 6	Bit 5	Description
	Reserved* <sup>3</sup>	CCLR1	CCLR0	
1, 2	0	0	0	TCNT clearing disabled (Initial value)
			1	TCNT cleared by TGRA compare match/input capture
		1	0	TCNT cleared by TGRB compare match
			1	TCNT cleared by counter clearing for another channel performing synchronous clearing/synchronous operation* <sup>1</sup>

Notes: \*<sup>1</sup> Synchronous operation setting is performed by setting the SYNC bit in TSYR to 1.

\*<sup>2</sup> When TGRC or TGRD is used as a buffer register, TCNT is not cleared because the buffer register setting has priority, and compare match/input capture does not occur.

\*<sup>3</sup> Bit 7 is reserved in channels 1 and 2. It is always read as 0 and cannot be modified.

**Bits 4 and 3—Clock Edge 1 and 0 (CKEG1, CKEG0):** These bits select the input clock edge. When the input clock is counted using both edges, the input clock period is halved (e.g.  $\phi/4$  both edges =  $\phi/2$  rising edge). If phase counting mode is used on channel 1, this setting is ignored and the phase counting mode setting has priority.

Bit 4	Bit 3	Description	
CKEG1	CKEG0		
0	0	Count at rising edge	(Initial value)
	1	Count at falling edge	
1	—	Count at both edges	

Note: Internal clock edge selection is valid when the input clock is  $\phi/4$  or slower. This setting is ignored if the input clock is  $\phi/1$ , or when overflow/underflow of another channel is selected.

**Bits 2 to 0—Time Prescaler 2 to 0 (TPSC2 to TPSC0):** These bits select the TCNT counter clock. The clock source can be selected independently for each channel. Table 10.4 shows the clock sources that can be set for each channel.

**Table 10.4 TPU Clock Sources**

Channel	Internal Clock						External Clock		Overflow/Underflow on Another Channel
	$\phi/1$	$\phi/4$	$\phi/16$	$\phi/64$	$\phi/256$	$\phi/1024$	TCLKA	TCLKB	
0	○	○	○	○			○	○	
1	○	○	○	○	○		○	○	○
2	○	○	○	○		○	○	○	

**Legend**

- : Setting
- Blank : No setting

Channel	Bit 2	Bit 1	Bit 0	Description
	TPSC2	TPSC1	TPSC0	
0	0	0	0	Internal clock: counts on $\phi/1$ (Initial value)
			1	Internal clock: counts on $\phi/4$
		1	0	Internal clock: counts on $\phi/16$
			1	Internal clock: counts on $\phi/64$
	1	0	0	External clock: counts on TCLKA pin input
			1	External clock: counts on TCLKB pin input
		1	0	Setting disabled
			1	Setting disabled

Channel	Bit 2	Bit 1	Bit 0	Description
	TPSC2	TPSC1	TPSC0	
1	0	0	0	Internal clock: counts on $\phi/1$ (Initial value)
			1	Internal clock: counts on $\phi/4$
		1	0	Internal clock: counts on $\phi/16$
			1	Internal clock: counts on $\phi/64$
	1	0	0	External clock: counts on TCLKA pin input
			1	External clock: counts on TCLKB pin input
		1	0	Internal clock: counts on $\phi/256$
			1	Setting disabled

Note: This setting is ignored when channel 1 is in phase counting mode.

Channel	Bit 2	Bit 1	Bit 0	Description
	TPSC2	TPSC1	TPSC0	
2	0	0	0	Internal clock: counts on $\phi/1$ (Initial value)
			1	Internal clock: counts on $\phi/4$
		1	0	Internal clock: counts on $\phi/16$
			1	Internal clock: counts on $\phi/64$
	1	0	0	External clock: counts on TCLKA pin input
			1	External clock: counts on TCLKB pin input
		1	0	Setting disabled
			1	Internal clock: counts on $\phi/1024$

## 10.2.2 Timer Mode Register (TMDR)

### Channel 0: TMDR0

Bit	:	7	6	5	4	3	2	1	0
		—	—	BFB	BFA	MD3	MD2	MD1	MD0
Initial value	:	1	1	0	0	0	0	0	0
R/W	:	—	—	R/W	R/W	R/W	R/W	R/W	R/W

### Channel 1: TMDR1

### Channel 2: TMDR2

Bit	:	7	6	5	4	3	2	1	0
		—	—	—	—	MD3	MD2	MD1	MD0
Initial value	:	1	1	0	0	0	0	0	0
R/W	:	—	—	—	—	R/W	R/W	R/W	R/W

The TMDR registers are 8-bit readable/writable registers that are used to set the operating mode for each channel. The TPU has three TMDR registers, one for each channel. The TMDR registers are initialized to H'CO by a reset, and in hardware standby mode.

**Bits 7 and 6—Reserved:** Read-only bits, always read as 1.

**Bit 5—Buffer Operation B (BFB):** Specifies whether TGRB is to operate in the normal way, or TGRB and TGRD are to be used together for buffer operation. When TGRD is used as a buffer register, TGRD input capture/output compare is not generated.

In channels 1 and 2, which have no TGRD, bit 5 is reserved. It is always read as 0 and cannot be modified.

#### Bit 5

BFB	Description
0	TGRB operates normally (Initial value)
1	TGRB and TGRD used together for buffer operation

**Bit 4—Buffer Operation A (BFA):** Specifies whether TGRA is to operate in the normal way, or TGRA and TGRC are to be used together for buffer operation. When TGRC is used as a buffer register, TGRC input capture/output compare is not generated.

In channels 1 and 2, which have no TGRC, bit 4 is reserved. It is always read as 0 and cannot be modified.

#### Bit 4

BFA	Description	
0	TGRA operates normally	(Initial value)
1	TGRA and TGRC used together for buffer operation	

**Bits 3 to 0—Modes 3 to 0 (MD3 to MD0):** These bits are used to set the timer operating mode.

Bit 3	Bit 2	Bit 1	Bit 0	Description				
MD3*1	MD2*2	MD1	MD0					
0	0	0	0	Normal operation	(Initial value)			
			1	Reserved				
			1	0	PWM mode 1			
				1	PWM mode 2			
			1	0	0	Phase counting mode 1		
					1	Phase counting mode 2		
					1	0	Phase counting mode 3	
						1	Phase counting mode 4	
1	*	*	*	Setting disabled				

\*: Don't care

Notes: \*1 MD3 is a reserved bit. In a write, it should always be written with 0.

\*2 Phase counting mode cannot be set for channels 0 and 2. In this case, 0 should always be written to MD2.

### 10.2.3 Timer I/O Control Register (TIOR)

#### Channel 0: TIOR0H

#### Channel 1: TIOR1

#### Channel 2: TIOR2

Bit	:	7	6	5	4	3	2	1	0
		IOB3	IOB2	IOB1	IOB0	IOA3	IOA2	IOA1	IOA0
Initial value	:	0	0	0	0	0	0	0	0
R/W	:	R/W	R/W	R/W	R/W	R/W	R/W	R/W	R/W

#### Channel 0: TIOR0L

Bit	:	7	6	5	4	3	2	1	0
		IOD3	IOD2	IOD1	IOD0	IOC3	IOC2	IOC1	IOC0
Initial value	:	0	0	0	0	0	0	0	0
R/W	:	R/W	R/W	R/W	R/W	R/W	R/W	R/W	R/W

Note: When TGRC or TGRD is designated for buffer operation, this setting is invalid and the register operates as a buffer register.

The TIOR registers are 8-bit registers that control the TGR registers. The TPU has four TIOR registers, two for channel 0, and one each for channels 1 and 2. The TIOR registers are initialized to H'00 by a reset, and in hardware standby mode.

Care is required since TIOR is affected by the TMDR setting. The initial output specified by TIOR is valid when the counter is stopped (the CST bit in TSTR is cleared to 0). Note also that, in PWM mode 2, the output at the point at which the counter is cleared to 0 is specified.



### Bits 7 to 4— I/O Control B3 to B0 (IOB3 to IOB0)

#### I/O Control D3 to D0 (IOD3 to IOD0):

Bits IOB3 to IOB0 specify the function of TGRB.

Bits IOD3 to IOD0 specify the function of TGRD.

Channel	Bit 7	Bit 6	Bit 5	Bit 4	Description
	IOB3	IOB2	IOB1	IOB0	
0	0	0	0	0	TGR0B is Output disabled (Initial value)
				1	output
				0	Initial output is 0
				1	output at compare match
	1	0	0	0	compare register
				1	0 output at compare match
				0	Toggle output at compare match
				1	
1	0	0	0	Output disabled	
			1	Initial output is 1	
			0	output	
			1	0 output at compare match	
1	0	0	0	capture register	
			1	1 output at compare match	
			0	Toggle output at compare match	
			1		
1	0	0	0	TGR0B is Capture input	
			1	input source is	
			*	TIOCB0 pin	
			*	Input capture at rising edge	
1	0	0	1	capture register	
			*	Input capture at falling edge	
1	0	0	1	capture register	
			*	Input capture at both edges	
1	0	0	1	capture register	
			*	Input capture at TCNT1 count- up/count-down* <sup>1</sup>	
1	0	0	1	capture register	
			*	Capture input source is channel 1/count clock	

\*: Don't care

Note: \*1 When bits TPSC2 to TPSC0 in TCR1 are set to B'000 and  $\emptyset/1$  is used as the TCNT1 count clock, this setting is invalid and input capture is not generated.

	Bit 7	Bit 6	Bit 5	Bit 4			
Channel	IOD3	IOD2	IOD1	IOD0	Description		
0	0	0	0	0	TGR0D is	Output disabled	(Initial value)
				1	output	Initial output is 0	0 output at compare match
				1	compare	output	1 output at compare match
				0	register* <sup>2</sup>	Toggle output at compare match	
	1	0	0	0		Output disabled	
				1		Initial output is 1	0 output at compare match
				1		output	1 output at compare match
				0		Toggle output at compare match	
	1	0	0	0	TGR0D is	Capture input	Input capture at rising edge
				1	input	source is	Input capture at falling edge
				1	capture	TIOCD0 pin	Input capture at both edges
				*	register* <sup>2</sup>	Capture input	Input capture at TCNT1
1	*	*			source is channel	count-up/count-down* <sup>1</sup>	
					1/count clock		

\*: Don't care

Notes: \*1 When bits TPSC2 to TPSC0 in TCR1 are set to B'000 and  $\emptyset/1$  is used as the TCNT1 count clock, this setting is invalid and input capture is not generated.

\*2 When the BFB bit in TMDR0 is set to 1 and TGR0D is used as a buffer register, this setting is invalid and input capture/output compare is not generated.

Channel	Bit 7	Bit 6	Bit 5	Bit 4	Description		
	IOB3	IOB2	IOB1	IOB0			
1	0	0	0	0	TGR1B is output compare register	Output disabled	(Initial value)
				1		Initial output is 0 output	0 output at compare match
				1		1 output at compare match	1 output at compare match
				1		Toggle output at compare match	Toggle output at compare match
	1	0	0	0	TGR1B is output compare register	Output disabled	(Initial value)
				1		Initial output is 1 output	0 output at compare match
				1		1 output at compare match	1 output at compare match
				1		Toggle output at compare match	Toggle output at compare match
	1	*	*	*	—	Setting disabled	

\*: Don't care

Channel	Bit 7	Bit 6	Bit 5	Bit 4	Description		
	IOB3	IOB2	IOB1	IOB0			
2	0	0	0	0	TGR2B is output compare register	Output disabled	(Initial value)
				1		Initial output is 0 output	0 output at compare match
				1		1 output at compare match	1 output at compare match
				1		Toggle output at compare match	Toggle output at compare match
	1	0	0	0	TGR2B is output compare register	Output disabled	(Initial value)
				1		Initial output is 1 output	0 output at compare match
				1		1 output at compare match	1 output at compare match
				1		Toggle output at compare match	Toggle output at compare match
	1	*	*	*	—	Setting disabled	

\*: Don't care

**Bits 3 to 0— I/O Control A3 to A0 (IOA3 to IOA0)****I/O Control C3 to C0 (IOC3 to IOC0):**

IOA3 to IOA0 specify the function of TGRA.

IOC3 to IOC0 specify the function of TGRC.

	<b>Bit 3</b>	<b>Bit 2</b>	<b>Bit 1</b>	<b>Bit 0</b>	
<b>Channel</b>	<b>IOA3</b>	<b>IOA2</b>	<b>IOA1</b>	<b>IOA0</b>	<b>Description</b>
0	0	0	0	0	TGR0A is Output disabled (Initial value)
				1	output Initial output is 0
				0	compare 0 output at compare match
				1	register 1 output at compare match
	1	0	0	0	Output disabled
				1	Initial output is 1
				0	0 output at compare match
				1	1 output at compare match
1	0	0	0	TGR0A is Capture input	
			1	input source is	
			*	capture TIOCA0 pin	
			*	register Input capture at both edges	
1	1	*	*	1	Capture input
				1	source is channel count-up/count-down

\*: Don't care

Channel	Bit 3	Bit 2	Bit 1	Bit 0	Description	
	IOC3	IOC2	IOC1	IOC0		
0	0	0	0	0	TGR0C is output compare register*1	Output disabled (Initial value)
				1	Initial output is 0 output	0 output at compare match
				0	1 output at compare match	
				1	Toggle output at compare match	
	1	0	0	0	TGR0C is output compare register*1	Output disabled
				1	Initial output is 1 output	0 output at compare match
				0	1 output at compare match	
				1	Toggle output at compare match	
	1	0	0	0	TGR0C is input capture register*1	Capture input source is TIOCC0 pin
				1	Input capture at rising edge	
				*	Input capture at falling edge	
				*	Input capture at both edges	
1	*	*	*	TGR0C is input capture register*1	Capture input source is channel 1/count clock	Input capture at TCNT1 count-up/count-down

\*: Don't care

Note: \*1 When the BFA bit in TMDR0 is set to 1 and TGR0C is used as a buffer register, this setting is invalid and input capture/output compare is not generated.

Channel	Bit 3	Bit 2	Bit 1	Bit 0	Description							
	IOA3	IOA2	IOA1	IOA0								
1	0	0	0	0	TGR1A is output compare register	Output disabled	(Initial value)					
				1			Initial output is 0 output	0 output at compare match				
				1				1 output at compare match				
				1				Toggle output at compare match				
				1			0	0	0	TGR1A is output compare register	Output disabled	
									1			Initial output is 1 output
	1	1 output at compare match										
	1	0	0	0	TGR1A is capture register	Capture input source is TIOCA1 pin	Input capture at rising edge					
				1			Input capture at falling edge					
				1			Input capture at both edges					
				1			*	*	0	TGR1A is capture register	Capture input source is TGR0A compare match/ input capture	Input capture at generation of channel 0/TGR0A compare match/ input capture
									1			
1												

\*: Don't care

Channel	Bit 3	Bit 2	Bit 1	Bit 0	Description							
	IOA3	IOA2	IOA1	IOA0								
2	0	0	0	0	TGR2A is output compare register	Output disabled	(Initial value)					
				1			Initial output is 0 output	0 output at compare match				
				1				1 output at compare match				
				1				Toggle output at compare match				
				1			0	0	0	TGR2A is output compare register	Output disabled	
									1			Initial output is 1 output
	1	1 output at compare match										
	1	*	0	0	TGR2A is capture register	Capture input source is TIOCA2 pin	Input capture at rising edge					
				1			Input capture at falling edge					
				1			Input capture at both edges					
				1			*	0	0	TGR2A is capture register	Capture input source is TIOCA2 pin	Input capture at generation of channel 0/TGR0A compare match/ input capture
									1			
1												

\*: Don't care

## 10.2.4 Timer Interrupt Enable Register (TIER)

### Channel 0: TIER0

Bit	:	7	6	5	4	3	2	1	0
		TTGE	—	—	TCIEV	TGIED	TGIEC	TGIEB	TGIEA
Initial value	:	0	1	0	0	0	0	0	0
R/W	:	R/W	—	—	R/W	R/W	R/W	R/W	R/W

### Channel 1: TIER1

### Channel 2: TIER2

Bit	:	7	6	5	4	3	2	1	0
		TTGE	—	TCIEU	TCIEV	—	—	TGIEB	TGIEA
Initial value	:	0	1	0	0	0	0	0	0
R/W	:	R/W	—	R/W	R/W	—	—	R/W	R/W

The TIER registers are 8-bit registers that control enabling or disabling of interrupt requests for each channel. The TPU has three TIER registers, one for each channel. The TIER registers are initialized to H'40 by a reset, and in hardware standby mode.

**Bit 7—A/D Conversion Start Request Enable (TTGE):** Enables or disables generation of A/D conversion start requests by TGRA input capture/compare match.

#### Bit 7

TTGE	Description
0	A/D conversion start request generation disabled (Initial value)
1	A/D conversion start request generation enabled

**Bit 6—Reserved:** Read-only bit, always read as 1.

**Bit 5—Underflow Interrupt Enable (TCIEU):** Enables or disables interrupt requests (TCIU) by the TCFU flag when the TCFU flag in TSR is set to 1 in channels 1 and 2.

In channel 0, bit 5 is reserved. It is always read as 0 and cannot be modified.

#### Bit 5

TCIEU	Description
0	Interrupt requests (TCIU) by TCFU disabled (Initial value)
1	Interrupt requests (TCIU) by TCFU enabled

**Bit 4—Overflow Interrupt Enable (TCIEV):** Enables or disables interrupt requests (TCIV) by the TCFV flag when the TCFV flag in TSR is set to 1.

#### Bit 4

TCIEV	Description
0	Interrupt requests (TCIV) by TCFV disabled (Initial value)
1	Interrupt requests (TCIV) by TCFV enabled

**Bit 3—TGR Interrupt Enable D (TGIED):** Enables or disables interrupt requests (TGID) by the TGFD bit when the TGFD bit in TSR is set to 1 in channel 0.

In channels 1 and 2, bit 3 is reserved. It is always read as 0 and cannot be modified.

#### Bit 3

TGIED	Description
0	Interrupt requests (TGID) by TGFD bit disabled (Initial value)
1	Interrupt requests (TGID) by TGFD bit enabled

**Bit 2—TGR Interrupt Enable C (TGIEC):** Enables or disables interrupt requests (TGIC) by the TGFC bit when the TGFC bit in TSR is set to 1 in channel 0.

In channels 1 and 2, bit 2 is reserved. It is always read as 0 and cannot be modified.

#### Bit 2

TGIEC	Description
0	Interrupt requests (TGIC) by TGFC bit disabled (Initial value)
1	Interrupt requests (TGIC) by TGFC bit enabled

**Bit 1—TGR Interrupt Enable B (TGIEB):** Enables or disables interrupt requests (TGIB) by the TGFB bit when the TGFB bit in TSR is set to 1.

#### Bit 1

TGIEB	Description
0	Interrupt requests (TGIB) by TGFB bit disabled (Initial value)
1	Interrupt requests (TGIB) by TGFB bit enabled



**Bit 0—TGR Interrupt Enable A (TGIEA):** Enables or disables interrupt requests (TGIA) by the TGFA bit when the TGFA bit in TSR is set to 1.

#### Bit 0

TGIEA	Description	
0	Interrupt requests (TGIA) by TGFA bit disabled	(Initial value)
1	Interrupt requests (TGIA) by TGFA bit enabled	

### 10.2.5 Timer Status Register (TSR)

#### Channel 0: TSR0

Bit	:	7	6	5	4	3	2	1	0
		—	—	—	TCFV	TGFD	TGFC	TGFB	TGFA
Initial value	:	1	1	0	0	0	0	0	0
R/W	:	—	—	—	R/(W)*	R/(W)*	R/(W)*	R/(W)*	R/(W)*

#### Channel 1: TSR1

#### Channel 2: TSR2

Bit	:	7	6	5	4	3	2	1	0
		TCFD	—	TCFU	TCFV	—	—	TGFB	TGFA
Initial value	:	1	1	0	0	0	0	0	0
R/W	:	R	—	R/(W)*	R/(W)*	—	—	R/(W)*	R/(W)*

Note: \* Can only be written with 0 for flag clearing.

The TSR registers are 8-bit registers that indicate the status of each channel. The TPU has three TSR registers, one for each channel. The TSR registers are initialized to H'CO by a reset, and in hardware standby mode.

**Bit 7—Count Direction Flag (TCFD):** Status flag that shows the direction in which TCNT counts in channels 1 and 2.

In channel 0, bit 7 is reserved. It is always read as 1 and cannot be modified.

#### Bit 7

TCFD	Description	
0	TCNT counts down	
1	TCNT counts up	(Initial value)

**Bit 6—Reserved:** Read-only bit, always read as 1 and cannot be modified.

**Bit 5—Underflow Flag (TCFU):** Status flag that indicates that TCNT underflow has occurred when channel 1 is set to phase counting mode.

In channels 0 and 2, bit 5 is reserved. It is always read as 0 and cannot be modified.

#### Bit 5

TCFU	Description	
0	[Clearing condition] When 0 is written to TCFU after reading TCFU = 1	(Initial value)
1	[Setting condition] When the TCNT value underflows (changes from H'0000 to H'FFFF)	

**Bit 4—Overflow Flag (TCFV):** Status flag that indicates that TCNT overflow has occurred.

#### Bit 4

TCFV	Description	
0	[Clearing condition] When 0 is written to TCFV after reading TCFV = 1	(Initial value)
1	[Setting condition] When the TCNT value overflows (changes from H'FFFF to H'0000 )	

**Bit 3—Input Capture/Output Compare Flag D (TGFD):** Status flag that indicates the occurrence of TGRD input capture or compare match in channel 0.

In channels 1 and 2, bit 3 is reserved. It is always read as 0 and cannot be modified.

#### Bit 3

TGFD	Description	
0	[Clearing conditions] <ul style="list-style-type: none"><li>When DTC is activated by TGID interrupt while DISEL bit of MRB in DTC is 0</li><li>When 0 is written to TGFD after reading TGFD = 1</li></ul>	(Initial value)
1	[Setting conditions] <ul style="list-style-type: none"><li>When TCNT = TGRD while TGRD is functioning as output compare register</li><li>When TCNT value is transferred to TGRD by input capture signal while TGRD is functioning as input capture register</li></ul>	

**Bit 2—Input Capture/Output Compare Flag C (TGFC):** Status flag that indicates the occurrence of TGRC input capture or compare match in channel 0.

In channels 1 and 2, bit 2 is reserved. It is always read as 0 and cannot be modified.

### Bit 2

Bit 2	Description
0	[Clearing conditions] (Initial value) <ul style="list-style-type: none"><li>• When DTC is activated by TGIC interrupt while DISEL bit of MRB in DTC is 0</li><li>• When 0 is written to TGFC after reading TGFC = 1</li></ul>
1	[Setting conditions] <ul style="list-style-type: none"><li>• When TCNT = TGRC while TGRC is functioning as output compare register</li><li>• When TCNT value is transferred to TGRC by input capture signal while TGRC is functioning as input capture register</li></ul>

**Bit 1—Input Capture/Output Compare Flag B (TGFB):** Status flag that indicates the occurrence of TGRB input capture (only for channel 0) or compare match.

### Bit 1

Bit 1	Description
0	[Clearing conditions] (Initial value) <ul style="list-style-type: none"><li>• When DTC is activated by TGIB interrupt while DISEL bit of MRB in DTC is 0</li><li>• When 0 is written to TGFB after reading TGFB = 1</li></ul>
1	[Setting conditions] <ul style="list-style-type: none"><li>• When TCNT = TGRB while TGRB is functioning as output compare register</li><li>• When TCNT value is transferred to TGRB by input capture signal while TGRB is functioning as input capture register (only for channel 0)</li></ul>

**Bit 0—Input Capture/Output Compare Flag A (TGFA):** Status flag that indicates the occurrence of TGRA input capture or compare match.

### Bit 0

Bit 0	Description
0	[Clearing conditions] (Initial value) <ul style="list-style-type: none"><li>• When DTC is activated by TGIA interrupt while DISEL bit of MRB in DTC is 0</li><li>• When 0 is written to TGFA after reading TGFA = 1</li></ul>
1	[Setting conditions] <ul style="list-style-type: none"><li>• When TCNT = TGRA while TGRA is functioning as output compare register</li><li>• When TCNT value is transferred to TGRA by input capture signal while TGRA is functioning as input capture register</li></ul>

## 10.2.6 Timer Counter (TCNT)

**Channel 0: TCNT0 (up-counter)**

**Channel 1: TCNT1 (up/down-counter\*)**

**Channel 2: TCNT2 (up/down-counter\*)**

Bit	:	15	14	13	12	11	10	9	8	7	6	5	4	3	2	1	0
Initial value	:	0	0	0	0	0	0	0	0	0	0	0	0	0	0	0	0
R/W	:	R/W	R/W	R/W	R/W	R/W	R/W	R/W	R/W	R/W	R/W	R/W	R/W	R/W	R/W	R/W	R/W

Note: \* These counters can be used as up/down-counters only in phase counting mode or when counting overflow/underflow on another channel. In other cases they function as up-counters.

The TCNT registers are 16-bit counters. The TPU has three TCNT counters, one for each channel.

The TCNT counters are initialized to H'0000 by a reset, and in hardware standby mode.

The TCNT counters cannot be accessed in 8-bit units; they must always be accessed as a 16-bit unit.

## 10.2.7 Timer General Register (TGR)

Bit	:	15	14	13	12	11	10	9	8	7	6	5	4	3	2	1	0
Initial value	:	1	1	1	1	1	1	1	1	1	1	1	1	1	1	1	1
R/W	:	R/W	R/W	R/W	R/W	R/W	R/W	R/W	R/W	R/W	R/W	R/W	R/W	R/W	R/W	R/W	R/W

The TGR registers are 16-bit registers with a dual function as output compare and input capture registers. The TPU has eight TGR registers, four for channel 0 and two each for channels 1 and 2. TGRC and TGRD for channel 0 can also be designated for operation as buffer registers\*. The TGR registers are initialized to H'FFFF by a reset, and in hardware standby mode.

The TGR registers cannot be accessed in 8-bit units; they must always be accessed as a 16-bit unit.

Note: \* TGR buffer register combinations are TGRA–TGRC and TGRB–TGRD.

## 10.2.8 Timer Start Register (TSTR)

Bit	:	7	6	5	4	3	2	1	0
		—	—	—	—	—	CST2	CST1	CST0
Initial value	:	0	0	0	0	0	0	0	0
R/W	:	—	—	—	—	—	R/W	R/W	R/W

TSTR is an 8-bit readable/writable register that selects operation/stoppage for channels 0 to 2. TSTR is initialized to H'00 by a reset, and in hardware standby mode.

TCNT counter operation must be halted before setting the operating mode in TMDR, or setting the TCNT count clock in TCR.

**Bits 7 to 3—Reserved:** Should always be written with 0.

**Bits 2 to 0—Counter Start 2 to 0 (CST2 to CST0):** These bits select operation or stoppage for TCNT.

### Bit n

CSTn	Description
0	TCNTn count operation is stopped (Initial value)
1	TCNTn performs count operation

n = 2 to 0

Note: If 0 is written to the CST bit during operation with the TIOC pin designated for output, the counter stops but the TIOC pin output compare output level is retained. If TIOR is written to when the CST bit is cleared to 0, the pin output level will be changed to the set initial output value.

## 10.2.9 Timer Synchro Register (TSYR)

Bit	:	7	6	5	4	3	2	1	0
		—	—	—	—	—	SYNC2	SYNC1	SYNC0
Initial value	:	0	0	0	0	0	0	0	0
R/W	:	—	—	—	—	—	R/W	R/W	R/W

TSYR is an 8-bit readable/writable register that selects independent operation or synchronous operation for the channel 0 to 2 TCNT counters. A channel performs synchronous operation when the corresponding bit in TSYR is set to 1.

TSYR is initialized to H'00 by a reset, and in hardware standby mode.

**Bits 7 to 3—Reserved:** Should always be written with 0.

**Bits 2 to 0—Timer Synchro 2 to 0 (SYNC2 to SYNC0):** These bits select whether operation is independent of or synchronized with other channels.

When synchronous operation is selected, synchronous presetting of multiple channels\*<sup>1</sup>, and synchronous clearing through counter clearing on another channel\*<sup>2</sup> are possible.

### Bit n

SYNCn	Description
0	TCNTn operates independently (TCNT presetting/clearing is unrelated to other channels) (Initial value)
1	TCNTn performs synchronous operation TCNT synchronous presetting/synchronous clearing is possible

n = 2 to 0

Notes: \*1 To set synchronous operation, the SYNC bits for at least two channels must be set to 1.

\*2 To set synchronous clearing, in addition to the SYNC bit, the TCNT clearing source must also be set by means of bits CCLR2 to CCLR0 in TCR.

## 10.2.10 Module Stop Control Register A (MSTPCRA)

Bit	:	7	6	5	4	3	2	1	0
		MSTPA7	MSTPA6	MSTPA5	MSTPA4	MSTPA3	MSTPA2	MSTPA1	MSTPA0
Initial value	:	0	0	1	1	1	1	1	1
R/W	:	R/W	R/W	R/W	R/W	R/W	R/W	R/W	R/W

MSTPCRA is an 8-bit readable/writable register that performs module stop mode control.

When the MSTPA5 bit in MSTPCR is set to 1, TPU operation stops at the end of the bus cycle and a transition is made to module stop mode. Registers cannot be read or written to in module stop mode. For details, see section 19.5, Module Stop Mode.

MSTPCRA is initialized to H'3F by a reset and in hardware standby mode. It is not initialized in software standby mode.

**Bit 5—Module Stop (MSTPA5):** Specifies the TPU module stop mode.

### Bit 5

MSTPA5	Description
0	TPU module stop mode cleared
1	TPU module stop mode set (Initial value)

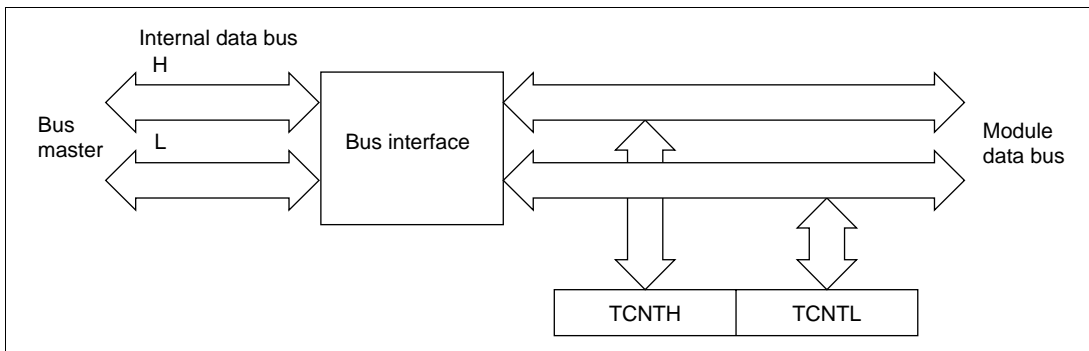
## 10.3 Interface to Bus Master

### 10.3.1 16-Bit Registers

TCNT and TGR are 16-bit registers. As the data bus to the bus master is 16 bits wide, these registers can be read and written to in 16-bit units.

These registers cannot be read or written to in 8-bit units; 16-bit access must always be used.

An example of 16-bit register access operation is shown in figure 10.2.

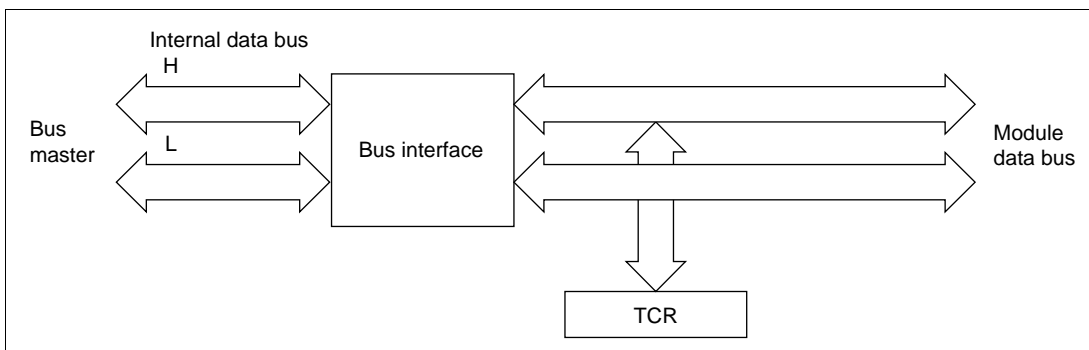


**Figure 10.2 16-Bit Register Access Operation [Bus Master ↔ TCNT (16 Bits)]**

### 10.3.2 8-Bit Registers

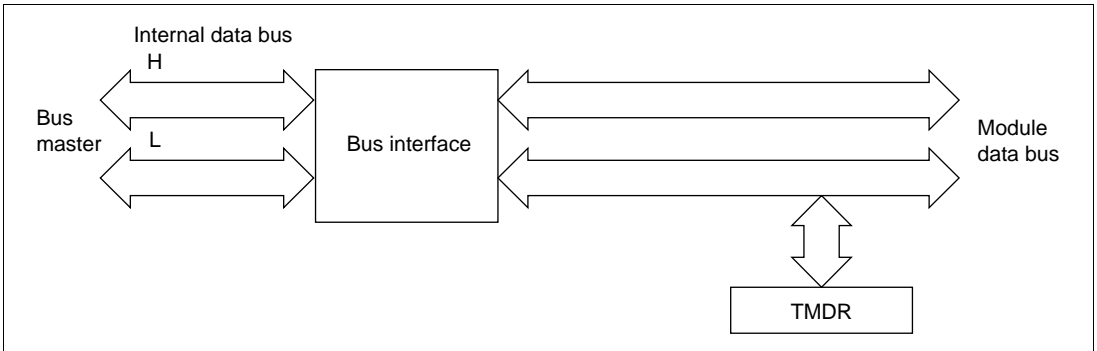
Registers other than TCNT and TGR are 8-bit. As the data bus to the CPU is 16 bits wide, these registers can be read and written to in 16-bit units. They can also be read and written to in 8-bit units.

Examples of 8-bit register access operation are shown in figures 10.3, 10.4, and 10.5.

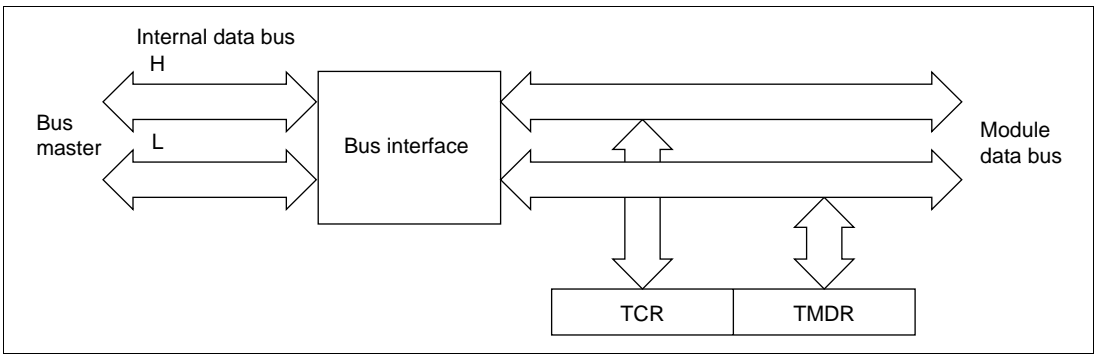


**Figure 10.3 8-Bit Register Access Operation [Bus Master ↔ TCR (Upper 8 Bits)]**





**Figure 10.4 8-Bit Register Access Operation [Bus Master ↔ TMDR (Lower 8 Bits)]**



**Figure 10.5 8-Bit Register Access Operation [Bus Master ↔ TCR and TMDR (16 Bits)]**

## 10.4 Operation

### 10.4.1 Overview

Operation in each mode is outlined below.

**Normal Operation:** Each channel has a TCNT and TGR register. TCNT performs up-counting, and is also capable of free-running operation, synchronous counting, and external event counting.

Each TGR can be used as an input capture register (excepted TGR1B and TGR2B) or output compare register.

**Synchronous Operation:** When synchronous operation is designated for a channel, TCNT for that channel performs synchronous presetting. That is, when TCNT for a channel designated for synchronous operation is rewritten, the TCNT counters for the other channels are also rewritten at the same time. Synchronous clearing of the TCNT counters is also possible by setting the timer synchronization bits in TSYR for channels designated for synchronous operation.

#### Buffer Operation

- When TGR is an output compare register  
When a compare match occurs, the value in the buffer register for the relevant channel is transferred to TGR.
- When TGR (excepted TGR1B and TGR2B) is an input capture register  
When input capture occurs, the value in TCNT is transfer to TGR and the value previously held in TGR is transferred to the buffer register.

**PWM Mode:** In this mode, a PWM waveform is output. The output level can be set by means of TIOR. A PWM waveform with a duty of between 0% and 100% can be output, according to the setting of each TGR register.

**Phase Counting Mode:** In this mode, TCNT is incremented or decremented by detecting the phases of two clocks input from the external clock input pins in channel 1. When phase counting mode is set, the corresponding TCLK pin functions as the clock pin, and TCNT performs up- or down-counting.

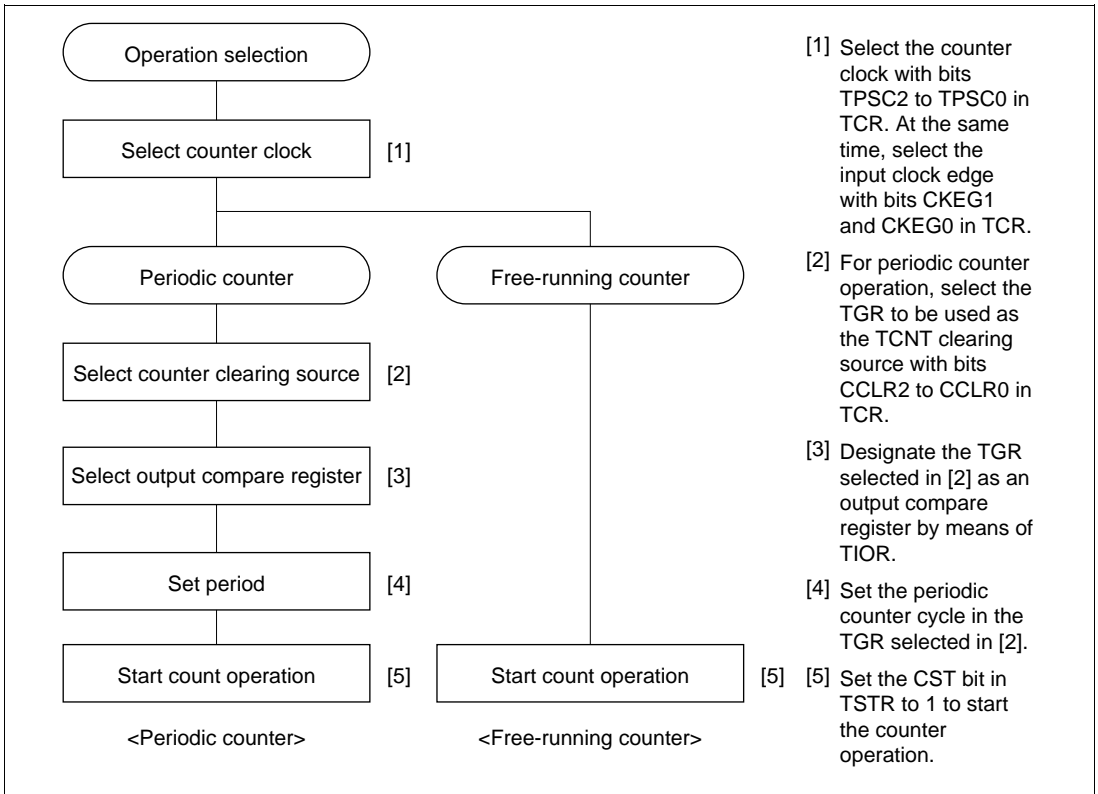
This can be used for two-phase encoder pulse input.

## 10.4.2 Basic Functions

**Counter Operation:** When one of bits CST0 to CST2 is set to 1 in TSTR, the TCNT counter for the corresponding channel starts counting. TCNT can operate as a free-running counter, periodic counter, and so on.

- Example of count operation setting procedure

Figure 10.6 shows an example of the count operation setting procedure.

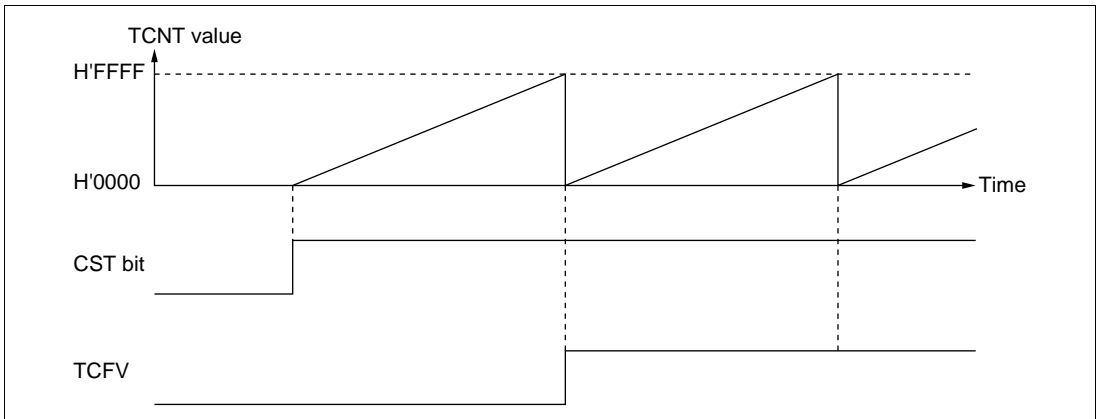


**Figure 10.6 Example of Counter Operation Setting Procedure**

- Free-running count operation and periodic count operation

Immediately after a reset, the TPU's TCNT counters are all designated as free-running counters. When the relevant bit in TSTR is set to 1 the corresponding TCNT counter starts up-count operation as a free-running counter. When TCNT overflows (from H'FFFF to H'0000), the TCFV bit in TSR is set to 1. If the value of the corresponding TCIEV bit in TIER is 1 at this point, the TPU requests an interrupt. After overflow, TCNT starts counting up again from H'0000.

Figure 10.7 illustrates free-running counter operation.

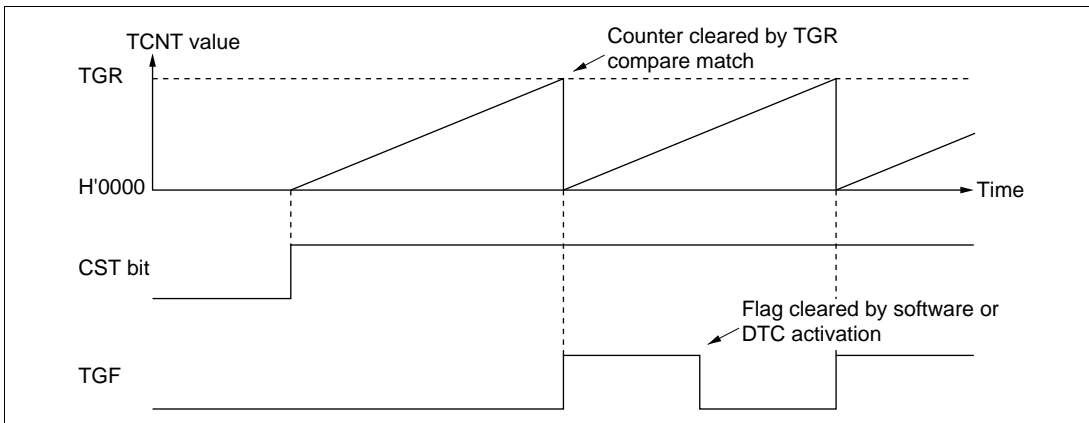


**Figure 10.7 Free-Running Counter Operation**

When compare match is selected as the TCNT clearing source, the TCNT counter for the relevant channel performs periodic count operation. The TGR register for setting the period is designated as an output compare register, and counter clearing by compare match is selected by means of bits CCLR2 to CCLR0 in TCR. After the settings have been made, TCNT starts up-count operation as periodic counter when the corresponding bit in TSTR is set to 1. When the count value matches the value in TGR, the TGF bit in TSR is set to 1 and TCNT is cleared to H'0000.

If the value of the corresponding TGIE bit in TIER is 1 at this point, the TPU requests an interrupt. After a compare match, TCNT starts counting up again from H'0000.

Figure 10.8 illustrates periodic counter operation.

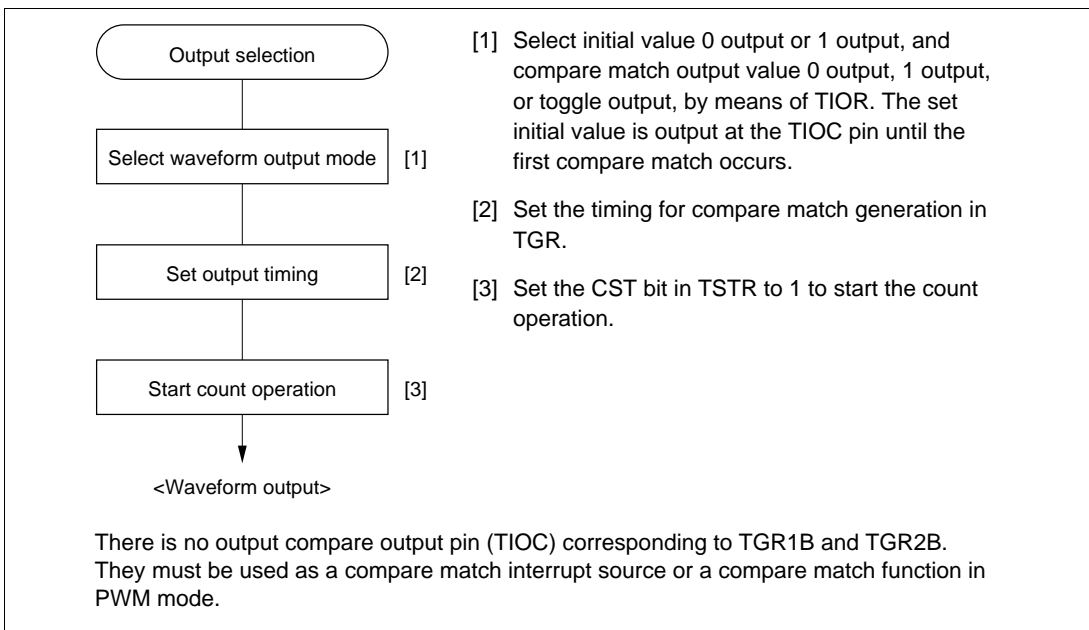


**Figure 10.8 Periodic Counter Operation**

**Waveform Output by Compare Match:** The TPU can perform 0, 1, or toggle output from the corresponding output pin using compare match.

- Example of setting procedure for waveform output by compare match

Figure 10.9 shows an example of the setting procedure for waveform output by compare match.

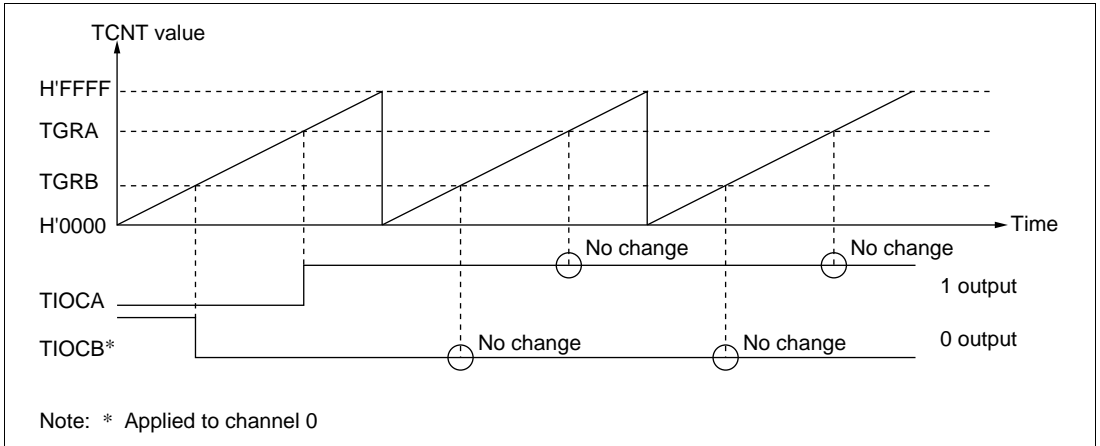


**Figure 10.9 Example Of Setting Procedure For Waveform Output By Compare Match**

- Examples of waveform output operation

Figure 10.10 shows an example of 0 output/1 output.

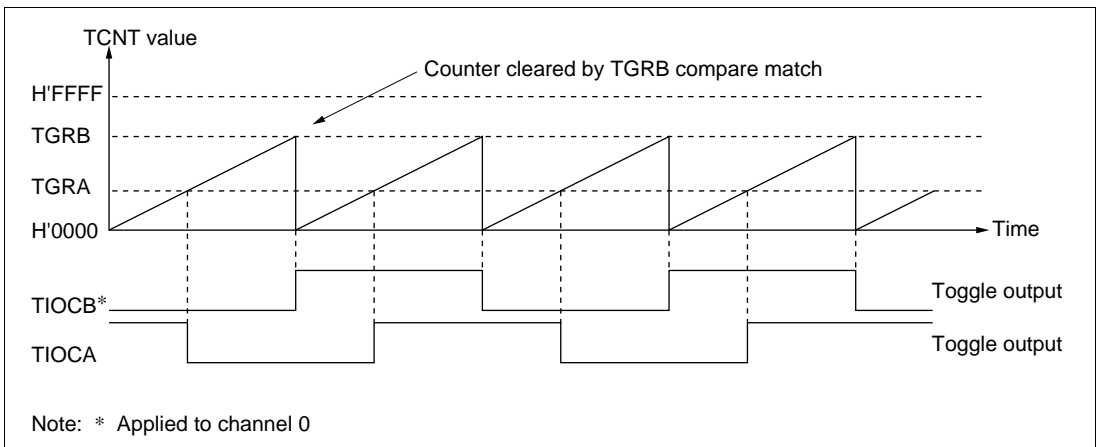
In this example TCNT has been designated as a free-running counter, and settings have been made so that 1 is output by compare match A, and 0 is output by compare match B. When the set level and the pin level coincide, the pin level does not change.



**Figure 10.10 Example of 0 Output/1 Output Operation**

Figure 10.11 shows an example of toggle output.

In this example TCNT has been designated as a periodic counter (with counter clearing performed by compare match B), and settings have been made so that output is toggled by both compare match A and compare match B.



**Figure 10.11 Example of Toggle Output Operation**

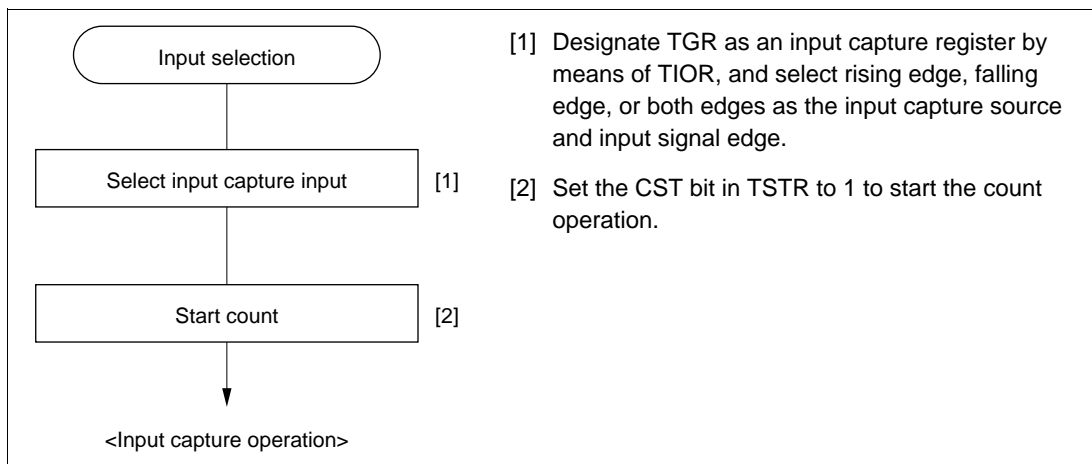
**Input Capture Function:** The TCNT value can be transferred to TGR on detection of the TIOC pin input edge.

Rising edge, falling edge, or both edges can be selected as the detected edge. For channels 0 and 1, it is also possible to specify another channel's counter input clock or compare match signal as the input capture source.

Note: When another channel's counter input clock is used as the input capture input for channel 0,  $\phi/1$  should not be selected as the counter input clock used for input capture input. Input capture will not be generated if  $\phi/1$  is selected.

- Example of input capture operation setting procedure

Figure 10.12 shows an example of the input capture operation setting procedure.

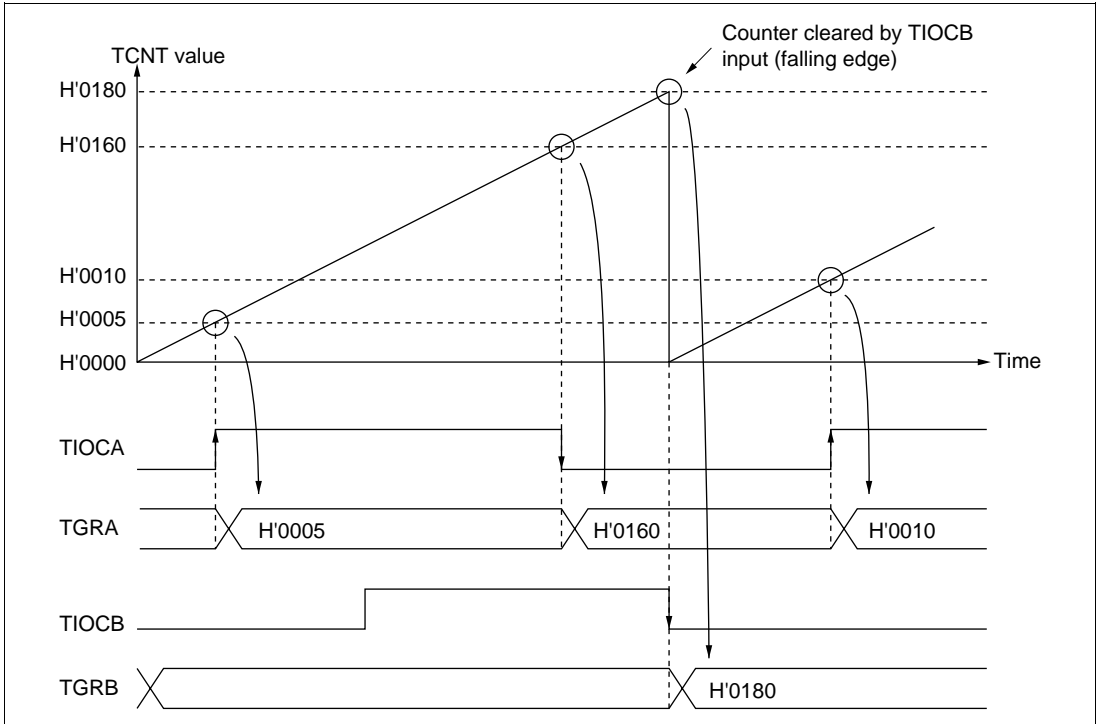


**Figure 10.12 Example of Input Capture Operation Setting Procedure**

- Example of input capture operation

Figure 10.13 shows an example of input capture operation of channel 0.

In this example both rising and falling edges have been selected as the TIOCA pin input capture input edge, falling edge has been selected as the TIOCB pin input capture input edge, and counter clearing by TGRB input capture has been designated for TCNT.



**Figure 10.13 Example of Input Capture Operation**



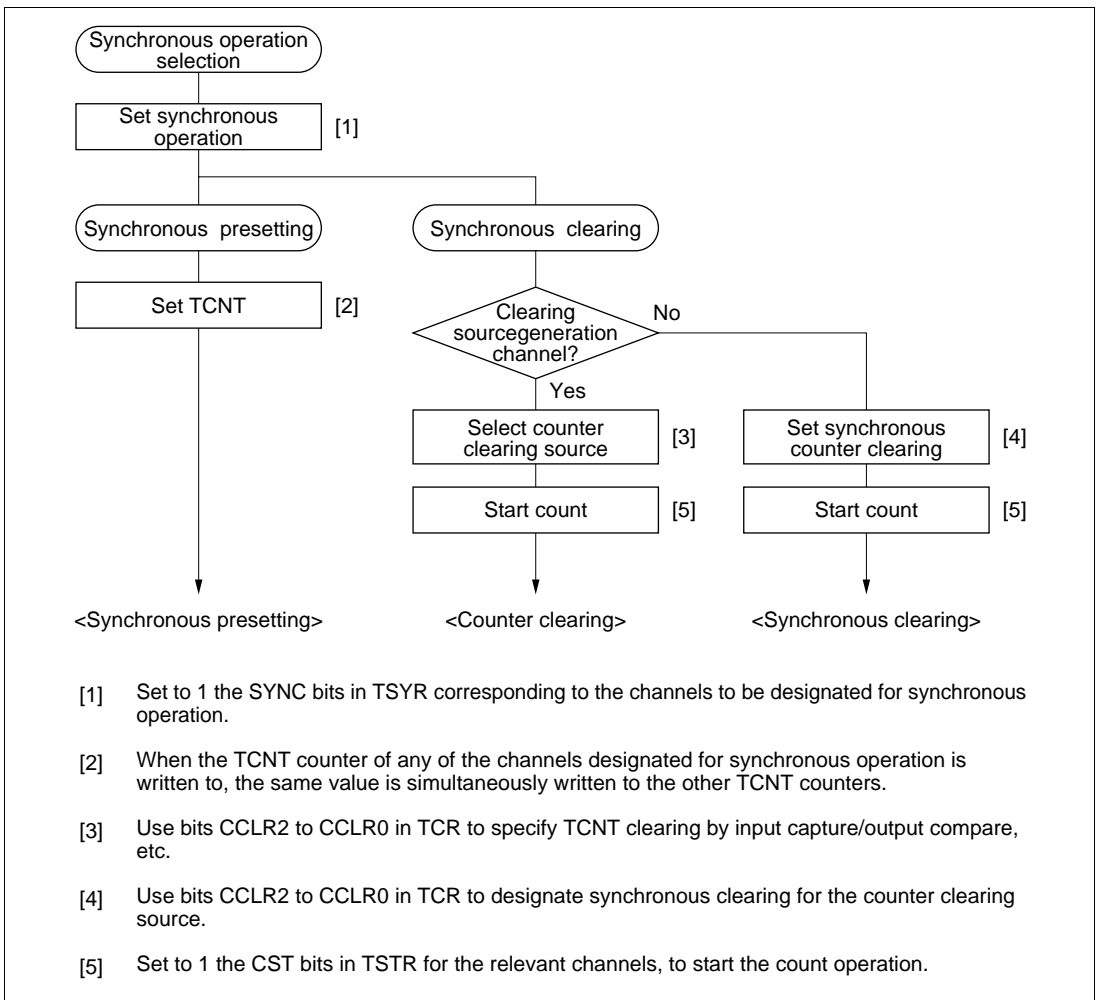
### 10.4.3 Synchronous Operation

In synchronous operation, the values in a number of TCNT counters can be rewritten simultaneously (synchronous presetting). Also, a number of TCNT counters can be cleared simultaneously by making the appropriate setting in TCR (synchronous clearing).

Synchronous operation enables TGR to be incremented with respect to a single time base.

Channels 0 to 2 can all be designated for synchronous operation.

**Example of Synchronous Operation Setting Procedure:** Figure 10.14 shows an example of the synchronous operation setting procedure.



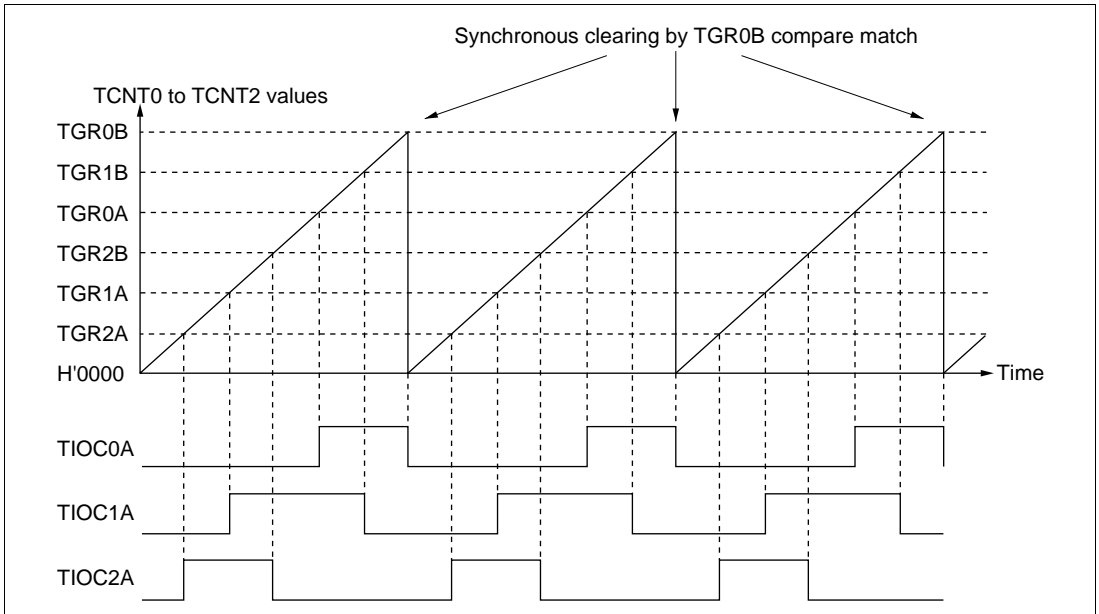
**Figure 10.14 Example of Synchronous Operation Setting Procedure**

**Example of Synchronous Operation:** Figure 10.15 shows an example of synchronous operation.

In this example, synchronous operation and PWM mode 1 have been designated for channels 0 to 2, TGR0B compare match has been set as the channel 0 counter clearing source, and synchronous clearing has been set for the channel 1 and 2 counter clearing source.

Three-phase PWM waveforms are output from pins TIOC0A, TIOC1A, and TIOC2A. At this time, synchronous presetting, and synchronous clearing by TGR0B compare match, is performed for channel 0 to 2 TCNT counters, and the data set in TGR0B is used as the PWM cycle.

For details of PWM modes, see section 10.4.5, PWM Modes.



**Figure 10.15 Example of Synchronous Operation**

## 10.4.4 Buffer Operation

Buffer operation, provided for channel 0, enables TGRC and TGRD to be used as buffer registers.

Buffer operation differs depending on whether TGR has been designated as an input capture register or as a compare match register.

Table 10.5 shows the register combinations used in buffer operation.

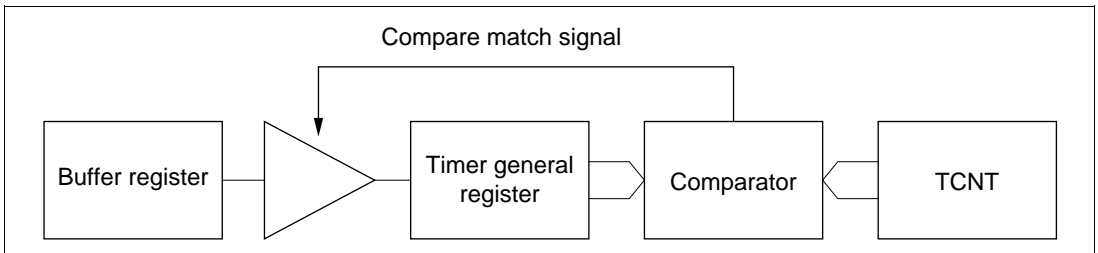
**Table 10.5 Register Combinations in Buffer Operation**

Channel	Timer General Register	Buffer Register
0	TGR0A	TGR0C
	TGR0B	TGR0D

- When TGR is an output compare register

When a compare match occurs, the value in the buffer register for the corresponding channel is transferred to the timer general register.

This operation is illustrated in figure 10.16.

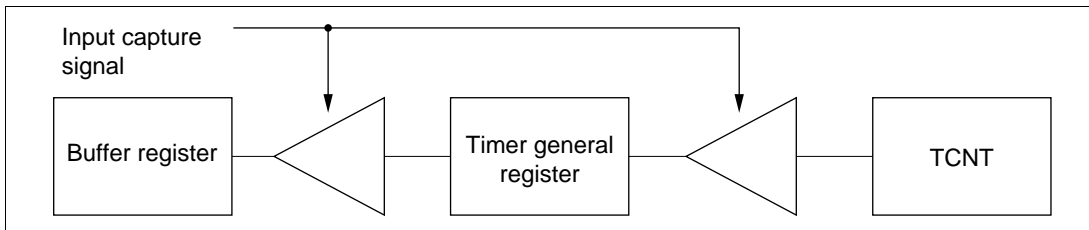


**Figure 10.16 Compare Match Buffer Operation**

- When TGR is an input capture register

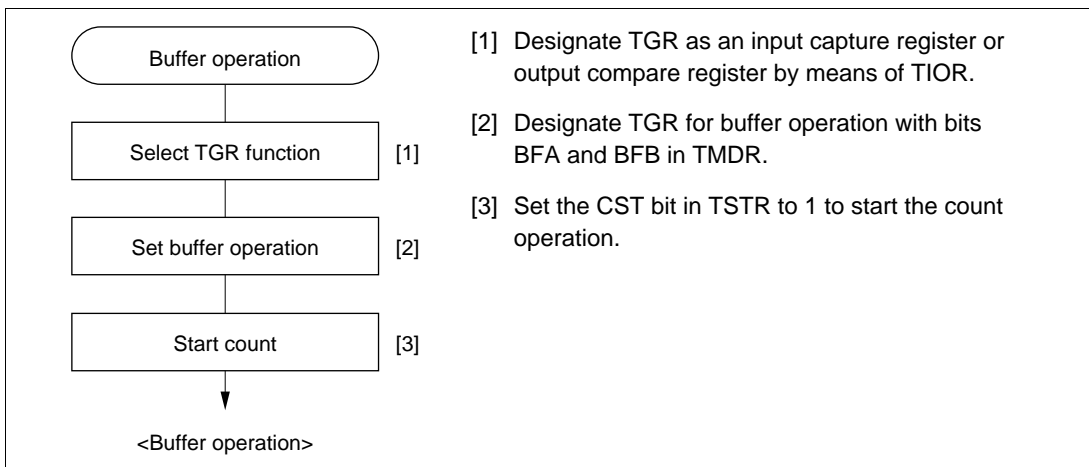
When input capture occurs, the value in TCNT is transferred to TGR and the value previously held in the timer general register is transferred to the buffer register.

This operation is illustrated in figure 10.17.



**Figure 10.17 Input Capture Buffer Operation**

**Example of Buffer Operation Setting Procedure:** Figure 10.18 shows an example of the buffer operation setting procedure.



**Figure 10.18 Example of Buffer Operation Setting Procedure**

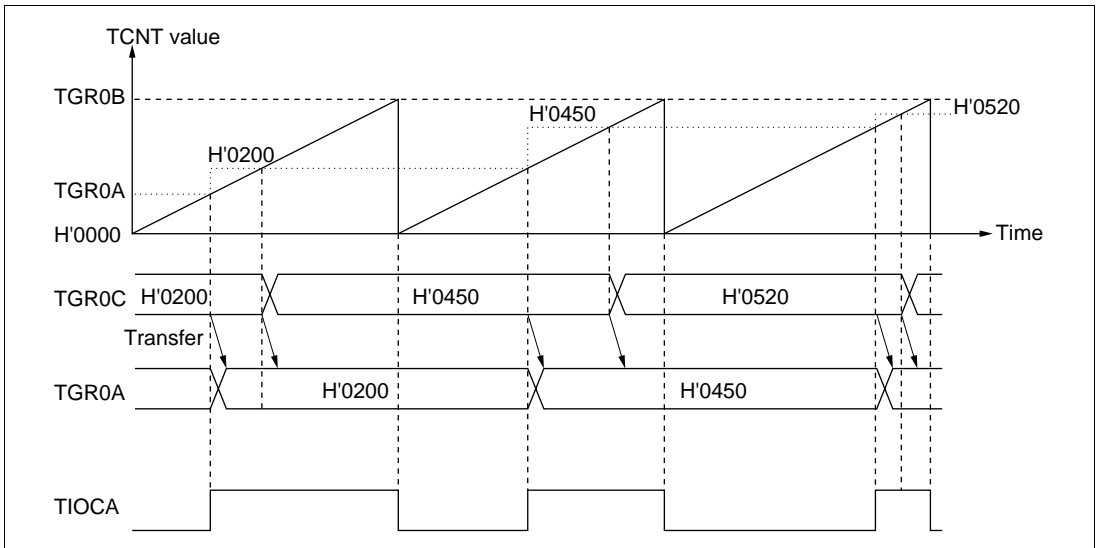
## Examples of Buffer Operation

- When TGR is an output compare register

Figure 10.19 shows an operation example in which PWM mode 1 has been designated for channel 0, and buffer operation has been designated for TGRA and TGRC. The settings used in this example are TCNT clearing by compare match B, 1 output at compare match A, and 0 output at compare match B.

As buffer operation has been set, when compare match A occurs the output changes and the value in buffer register TGRC is simultaneously transferred to timer general register TGRA. This operation is repeated each time compare match A occurs.

For details of PWM modes, see section 10.4.5, PWM Modes.



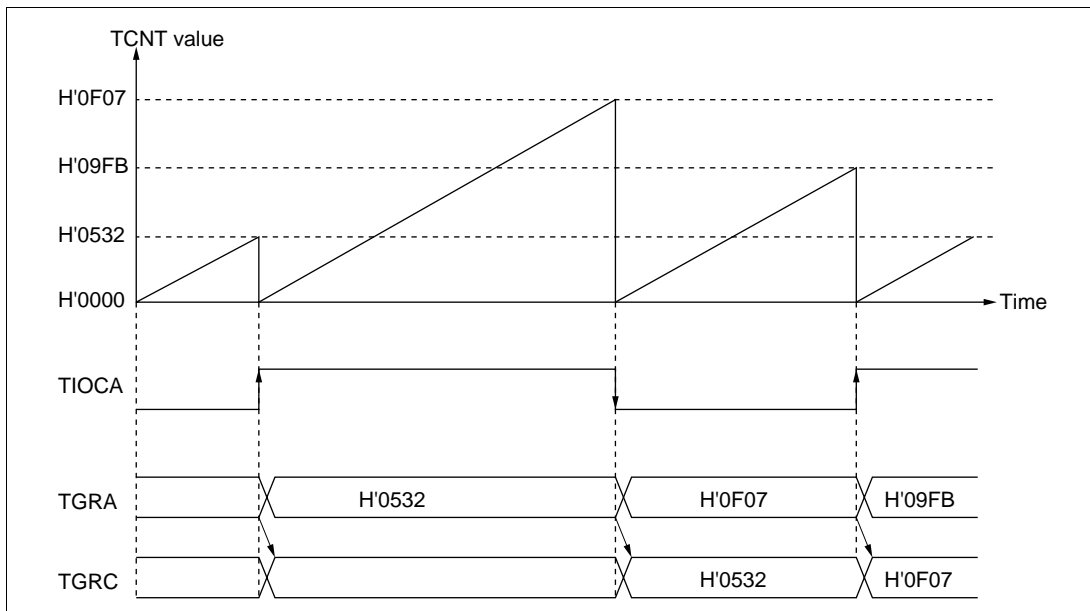
**Figure 10.19 Example of Buffer Operation (1)**

- When TGR is an input capture register

Figure 10.20 shows an operation example in which TGRA has been designated as an input capture register, and buffer operation has been designated for TGRA and TGRC.

Counter clearing by TGRA input capture has been set for TCNT, and both rising and falling edges have been selected as the TIOCA pin input capture input edge.

As buffer operation has been set, when the TCNT value is stored in TGRA upon occurrence of input capture A, the value previously stored in TGRA is simultaneously transferred to TGRC.



**Figure 10.20 Example of Buffer Operation (2)**

### 10.4.5 PWM Modes

In PWM mode, PWM waveforms are output from the output pins. 0, 1, or toggle output can be selected as the output level in response to compare match of each TGR.

Designating TGR compare match as the counter clearing source enables the period to be set in that register. All channels can be designated for PWM mode independently. Synchronous operation is also possible.

There are two PWM modes, as described below.

- PWM mode 1

PWM output is generated from the TIOCA and TIOCC pins by pairing TGRA with TGRB and TGRC with TGRD. The output specified by bits IOA3 to IOA0 and IOC3 to IOC0 in TIOR is output from the TIOCA and TIOCC pins at compare matches A and C, and the output specified by bits IOB3 to IOB0 and IOD3 to IOD0 in TIOR is output at compare matches B and D. The initial output value is the value set in TGRA or TGRC. If the set values of paired TGRs are identical, the output value does not change when a compare match occurs.

In PWM mode 1, a maximum 4-phase PWM output is possible.

- PWM mode 2

PWM output is generated using one TGR as the cycle register and the others as duty registers. The output specified in TIOR is performed by means of compare matches. Upon counter clearing by a synchronization register compare match, the output value of each pin is the initial value set in TIOR. If the set values of the cycle and duty registers are identical, the output value does not change when a compare match occurs.

In PWM mode 2, a maximum 6-phase PWM output is possible by combined use with synchronous operation.

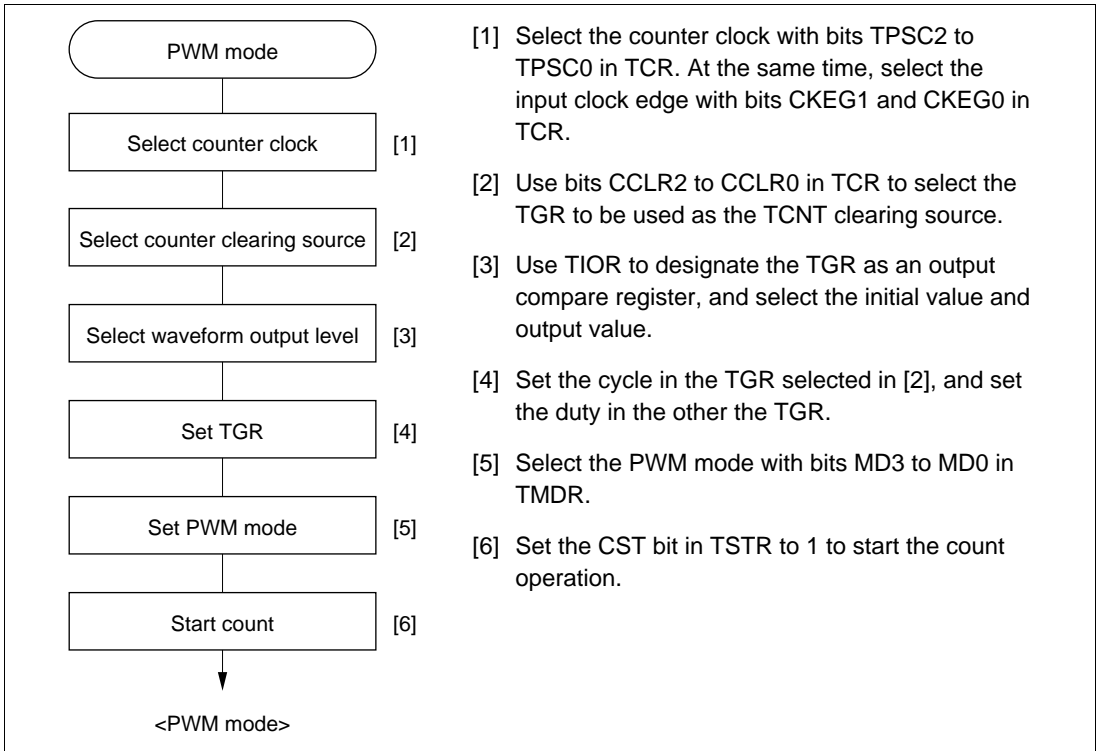
The correspondence between PWM output pins and registers is shown in table 10.6.

**Table 10.6 PWM Output Registers and Output Pins**

Channel	Registers	Output Pins	
		PWM Mode 1	PWM Mode 2
0	TGR0A	TIOCA0	TIOCA0
	TGR0B		TIOCB0
	TGR0C	TIOCC0	TIOCC0
	TGR0D		TIOCD0
1	TGR1A	TIOCA1	TIOCA1
	TGR1B		—
2	TGR2A	TIOCA2	TIOCA2
	TGR2B		—

Note: In PWM mode 2, PWM output is not possible for the TGR register in which the period is set. There is no output pins corresponding to TGR1B and TGR2B in PWM mode 2. They must be used as cycle registers.

**Example of PWM Mode Setting Procedure:** Figure 10.21 shows an example of the PWM mode setting procedure.



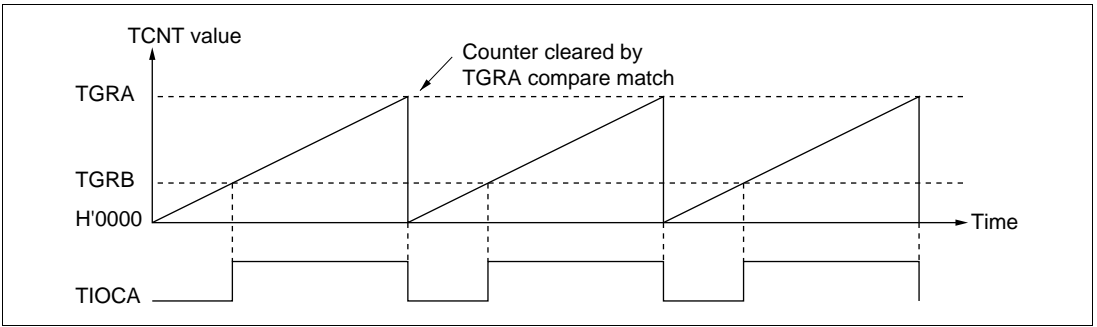
**Figure 10.21 Example of PWM Mode Setting Procedure**

**Examples of PWM Mode Operation:** Figure 10.22 shows an example of PWM mode 1 operation.

In this example, TGRA compare match is set as the TCNT clearing source, 0 is set for the TGRA initial output value and output value, and 1 is set as the TGRB output value.

In this case, the value set in TGRA is used as the period, and the values set in TGRB registers as the duty.



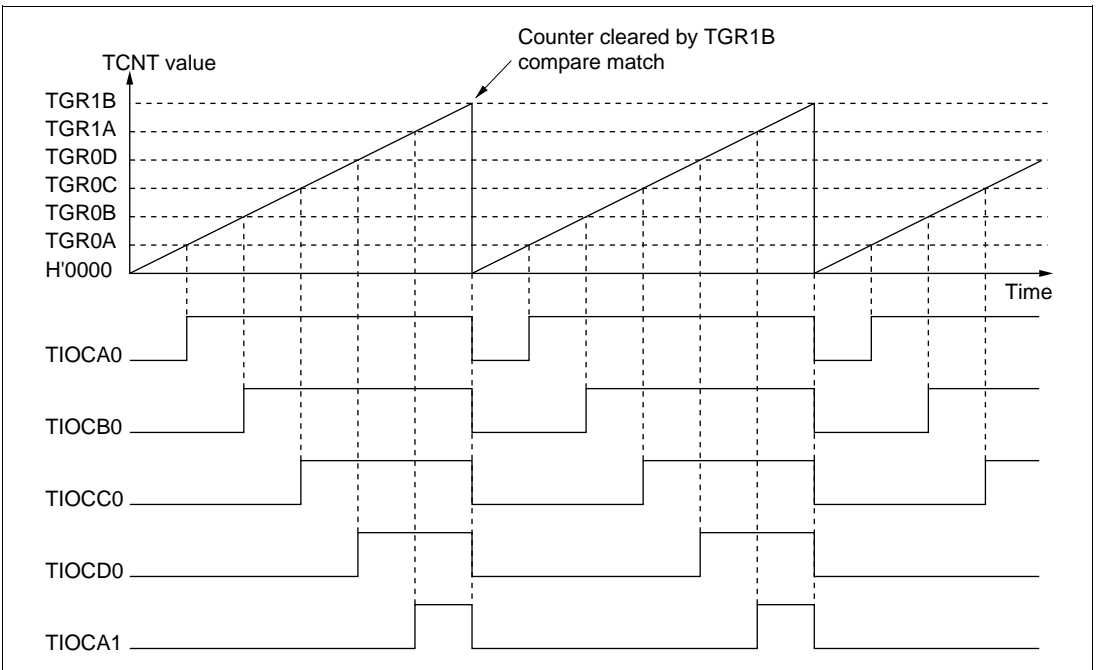


**Figure 10.22 Example of PWM Mode Operation (1)**

Figure 10.23 shows an example of PWM mode 2 operation.

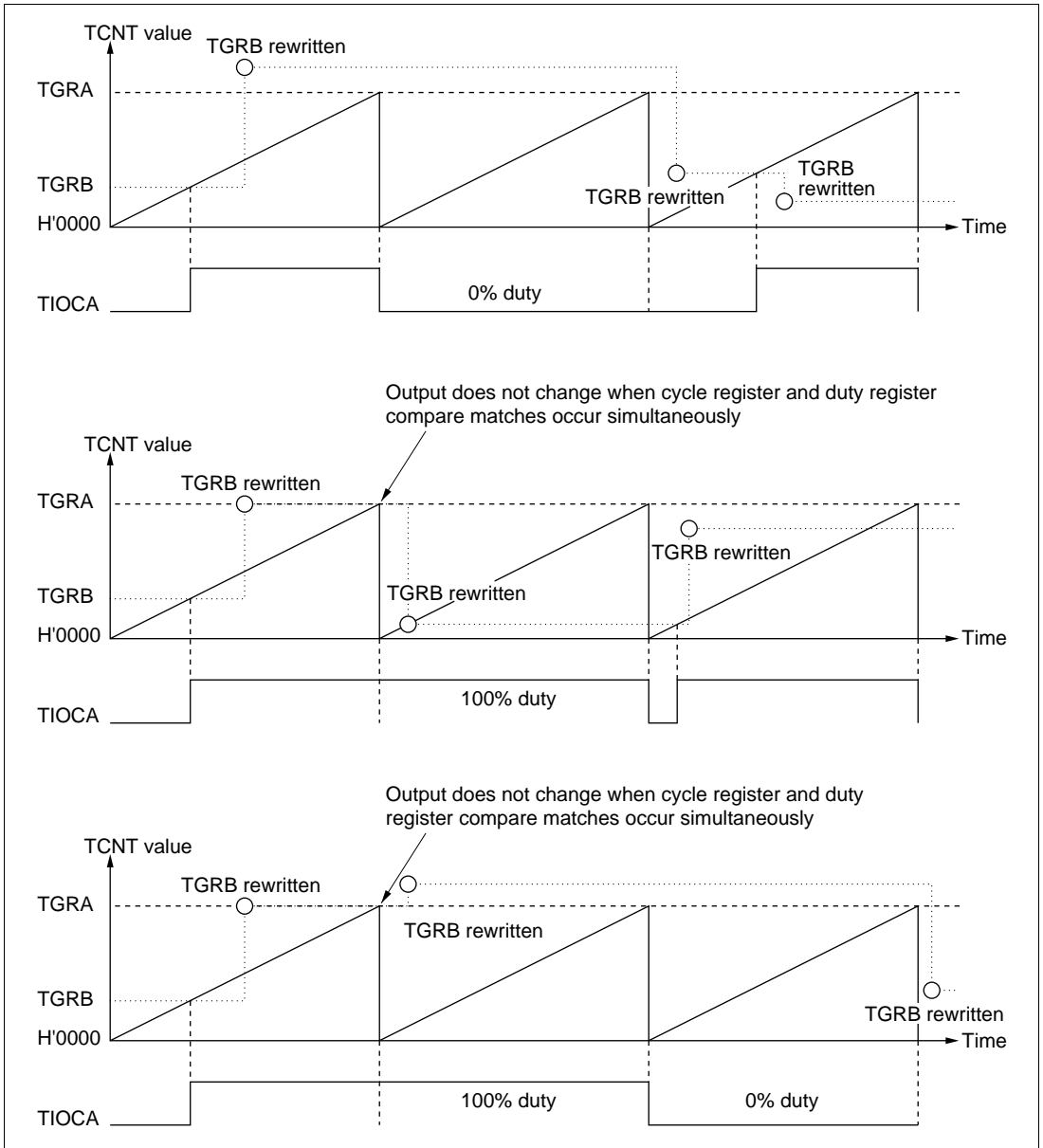
In this example, synchronous operation is designated for channels 0 and 1, TGR1B compare match is set as the TCNT clearing source, and 0 is set for the initial output value and 1 for the output value of the other TGR registers (TGR0A to TGR0D, TGR1A), to output a 5-phase PWM waveform.

In this case, the value set in TGR1B is used as the cycle, and the values set in the other TGRs as the duty.



**Figure 10.23 Example of PWM Mode Operation (2)**

Figure 10.24 shows examples of PWM waveform output with 0% duty and 100% duty in PWM mode.



**Figure 10.24 Example of PWM Mode Operation (3)**

## 10.4.6 Phase Counting Mode

In phase counting mode, the phase difference between two external clock inputs is detected and TCNT is incremented/decremented accordingly. This mode can be set for channel 1.

When phase counting mode is set, an external clock is selected as the counter input clock and TCNT operates as an up/down-counter regardless of the setting of bits TPSC2 to TPSC0 and bits CKEG1 and CKEG0 in TCR. However, the functions of bits CCLR1 and CCLR0 in TCR, and of TIOR, TIER, and TGR are valid, and input capture/compare match and interrupt functions can be used.

When overflow occurs while TCNT is counting up, the TCFV flag in TSR is set; when underflow occurs while TCNT is counting down, the TCFU flag is set.

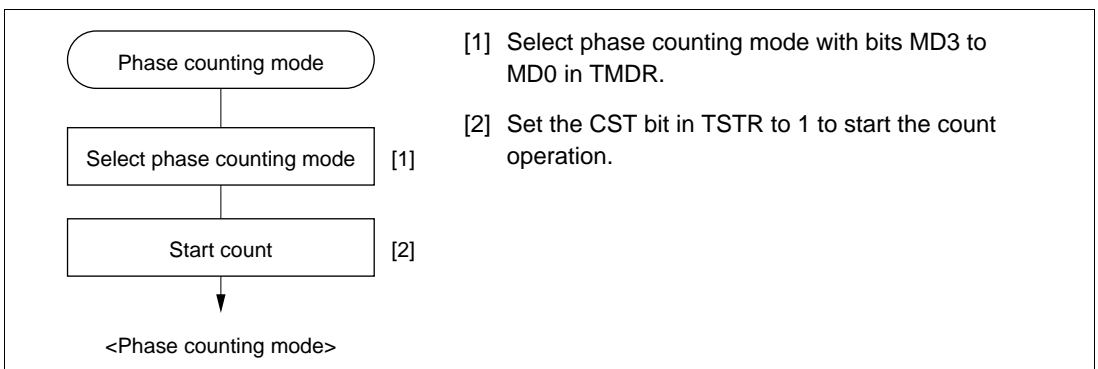
The TCFD bit in TSR is the count direction flag. Reading the TCFD flag provides an indication of whether TCNT is counting up or down.

Table 10.7 shows the correspondence between external clock pins and channels.

**Table 10.7 Phase Counting Mode Clock Input Pins**

Channels	External Clock Pins	
	A-Phase	B-Phase
When channel 1 is set to phase counting mode	TCLKA	TCLKB

**Example of Phase Counting Mode Setting Procedure:** Figure 10.25 shows an example of the phase counting mode setting procedure.

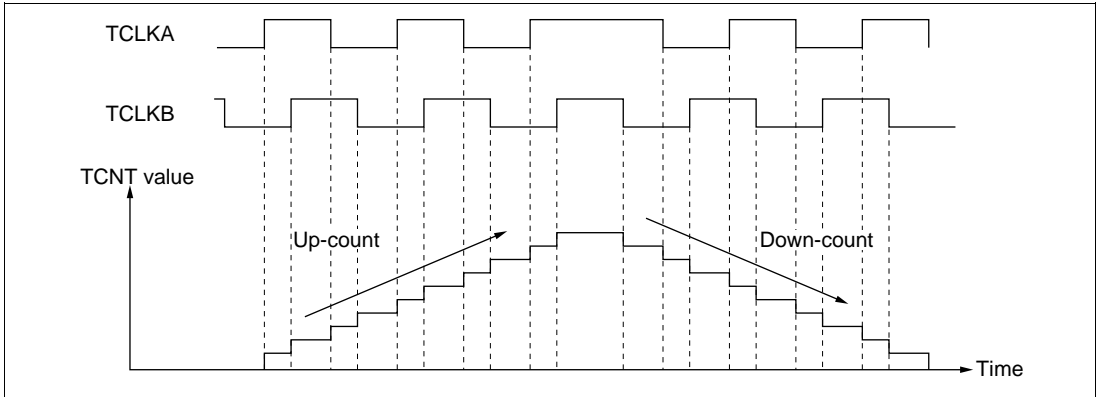


**Figure 10.25 Example of Phase Counting Mode Setting Procedure**

**Examples of Phase Counting Mode Operation:** In phase counting mode, TCNT counts up or down according to the phase difference between two external clocks. There are four modes, according to the count conditions.

- Phase counting mode 1

Figure 10.26 shows an example of phase counting mode 1 operation, and table 10.8 summarizes the TCNT up/down-count conditions.



**Figure 10.26 Example of Phase Counting Mode 1 Operation**

**Table 10.8 Up/Down-Count Conditions in Phase Counting Mode 1**

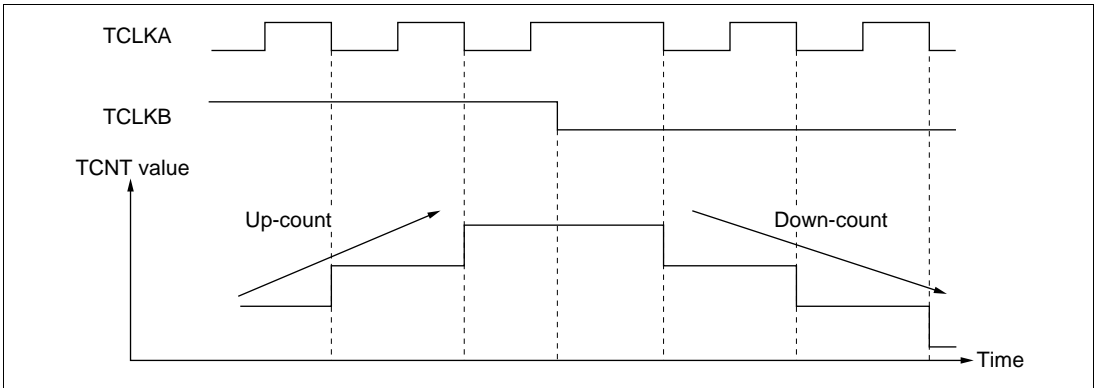
TCLKA	TCLKB	Operation
High level		Up-count
Low level		
	Low level	
	High level	
High level		Down-count
Low level		
	High level	
	Low level	

Legend

- : Rising edge
- : Falling edge

- Phase counting mode 2

Figure 10.27 shows an example of phase counting mode 2 operation, and table 10.9 summarizes the TCNT up/down-count conditions.



**Figure 10.27 Example of Phase Counting Mode 2 Operation**

**Table 10.9 Up/Down-Count Conditions in Phase Counting Mode 2**

TCLKA	TCLKB	Operation
High level	$\uparrow$	Don't care
Low level	$\downarrow$	Don't care
$\uparrow$	Low level	Don't care
$\downarrow$	High level	Up-count
High level	$\downarrow$	Don't care
Low level	$\uparrow$	Don't care
$\uparrow$	High level	Don't care
$\downarrow$	Low level	Down-count

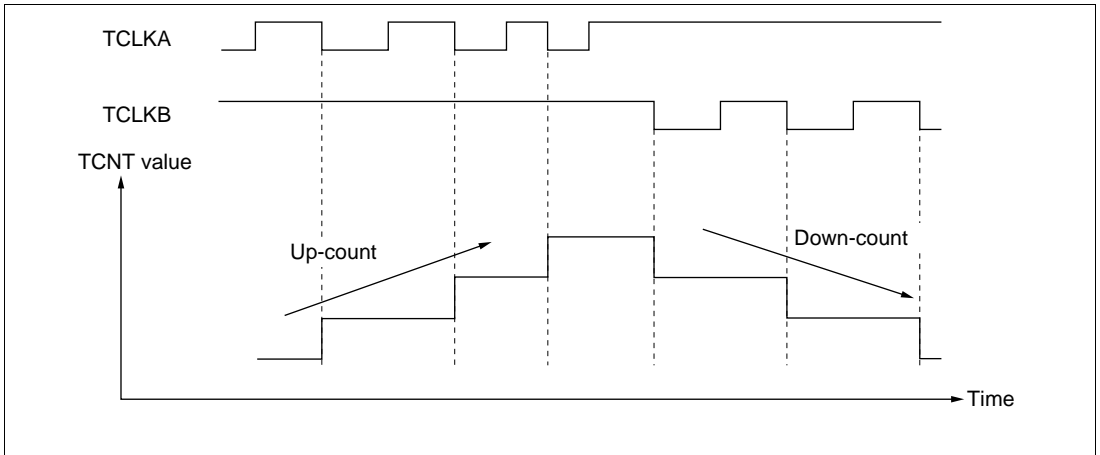
Legend

$\uparrow$  : Rising edge

$\downarrow$  : Falling edge

- Phase counting mode 3

Figure 10.28 shows an example of phase counting mode 3 operation, and table 10.10 summarizes the TCNT up/down-count conditions.



**Figure 10.28 Example of Phase Counting Mode 3 Operation**

**Table 10.10 Up/Down-Count Conditions in Phase Counting Mode 3**

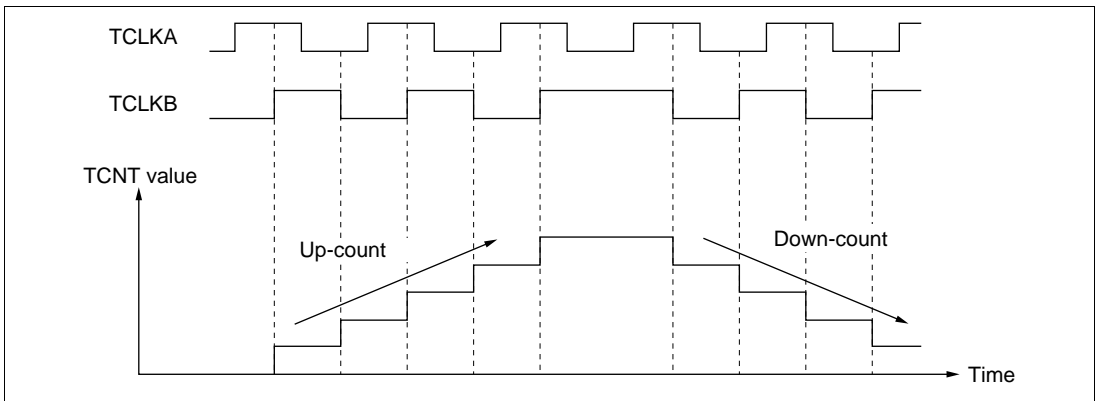
TCLKA	TCLKB	Operation
High level	$\uparrow$	Don't care
Low level	$\downarrow$	Don't care
$\uparrow$	Low level	Don't care
$\downarrow$	High level	Up-count
High level	$\downarrow$	Down-count
Low level	$\uparrow$	Don't care
$\uparrow$	High level	Don't care
$\downarrow$	Low level	Don't care

Legend

- $\uparrow$  : Rising edge
- $\downarrow$  : Falling edge

- Phase counting mode 4

Figure 10.29 shows an example of phase counting mode 4 operation, and table 10.11 summarizes the TCNT up/down-count conditions.



**Figure 10.29 Example of Phase Counting Mode 4 Operation**

**Table 10.11 Up/Down-Count Conditions in Phase Counting Mode 4**

TCLKA	TCLKB	Operation
High level	↗	Up-count
Low level	↘	Up-count
↗	Low level	Don't care
↘	High level	Don't care
High level	↘	Down-count
Low level	↗	Down-count
↗	High level	Don't care
↘	Low level	Don't care

Legend

- ↗ : Rising edge
- ↘ : Falling edge

**Phase Counting Mode Application Example:** Figure 10.30 shows an example in which phase counting mode is designated for channel 1, and channel 1 is coupled with channel 0 to input servo motor 2-phase encoder pulses in order to detect the position or speed.

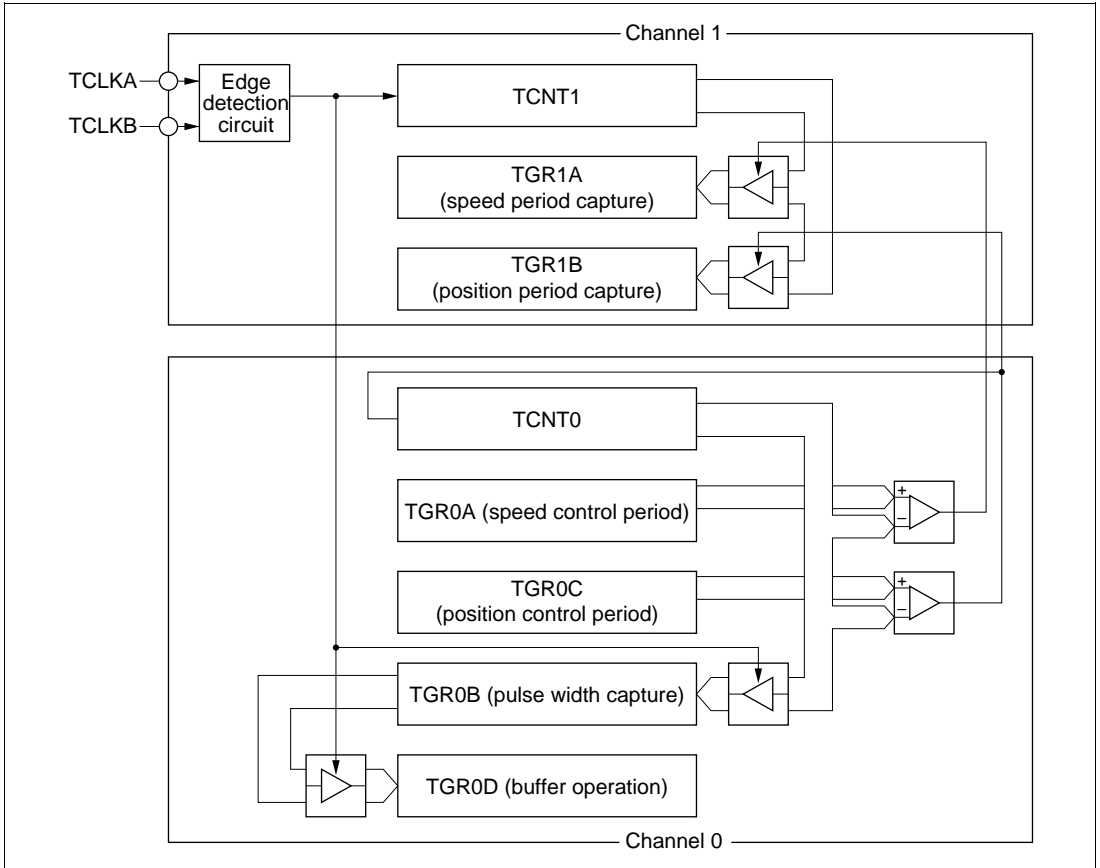
Channel 1 is set to phase counting mode 1, and the encoder pulse A-phase and B-phase are input to TCLKA and TCLKB.

Channel 0 operates with TCNT counter clearing by TGR0C compare match; TGR0A and TGR0C are used for the compare match function, and are set with the speed control period and position

control period. TGR0B is used for input capture, with TGR0B and TGR0D operating in buffer mode. The channel 1 counter input clock is designated as the TGR0B input capture source, and detection of the pulse width of 2-phase encoder 4-multiplication pulses is performed.

TGR1A and TGR1B for channel 1 are designated for input capture, channel 0 TGR0A and TGR0C compare matches are selected as the input capture source, and store the up/down-counter values for the control periods.

This procedure enables accurate position/speed detection to be achieved.



**Figure 10.30 Phase Counting Mode Application Example**





**Input Capture/Compare Match Interrupt:** An interrupt is requested if the TGIE bit in TIER is set to 1 when the TGF flag in TSR is set to 1 by the occurrence of a TGR input capture/compare match on a particular channel. The interrupt request is cleared by clearing the TGF flag to 0. The TPU has eight input capture/compare match interrupts, four for channel 0, and two each for channels 1 and 2.

**Overflow Interrupt:** An interrupt is requested if the TCIEV bit in TIER is set to 1 when the TCFV flag in TSR is set to 1 by the occurrence of TCNT overflow on a channel. The interrupt request is cleared by clearing the TCFV flag to 0. The TPU has three overflow interrupts, one for each channel.

**Underflow Interrupt:** An interrupt is requested if the TCIEU bit in TIER is set to 1 when the TCFU flag in TSR is set to 1 by the occurrence of TCNT underflow on a channel. The interrupt request is cleared by clearing the TCFU flag to 0. The TPU has two underflow interrupts, one each for channels 1 and 2.

### 10.5.2 DTC Activation

**DTC Activation:** The DTC can be activated by the TGR input capture/compare match interrupt for a channel. For details, see section 8, Data Transfer Controller (DTC).

A total of 8 TPU input capture/compare match interrupts can be used as DTC activation sources, four for channel 0, and two each for channels 1 and 2.

### 10.5.3 A/D Converter Activation

The A/D converter can be activated by the TGRA input capture/compare match for a channel.

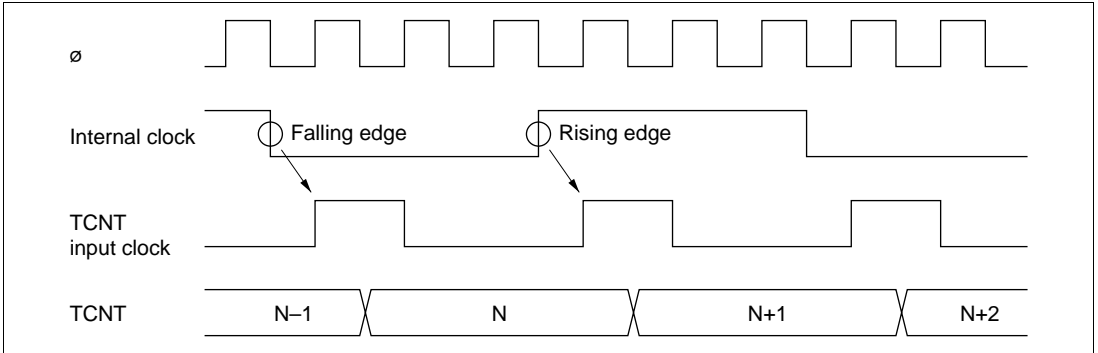
If the TTGE bit in TIER is set to 1 when the TGFA flag in TSR is set to 1 by the occurrence of a TGRA input capture/compare match on a particular channel, a request to start A/D conversion is sent to the A/D converter. If the TPU conversion start trigger has been selected on the A/D converter side at this time, A/D conversion is started.

In the TPU, a total of three TGRA input capture/compare match interrupts can be used as A/D converter conversion start sources, one for each channel.

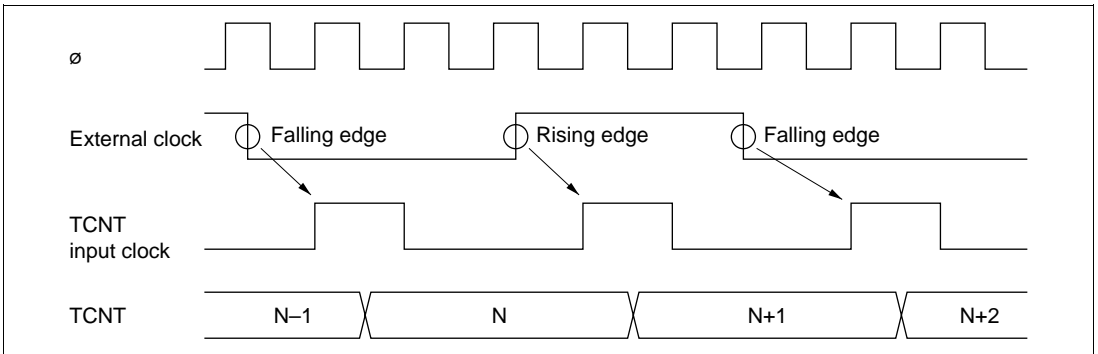
## 10.6 Operation Timing

### 10.6.1 Input/Output Timing

**TCNT Count Timing:** Figure 10.31 shows TCNT count timing in internal clock operation, and figure 10.32 shows TCNT count timing in external clock operation.



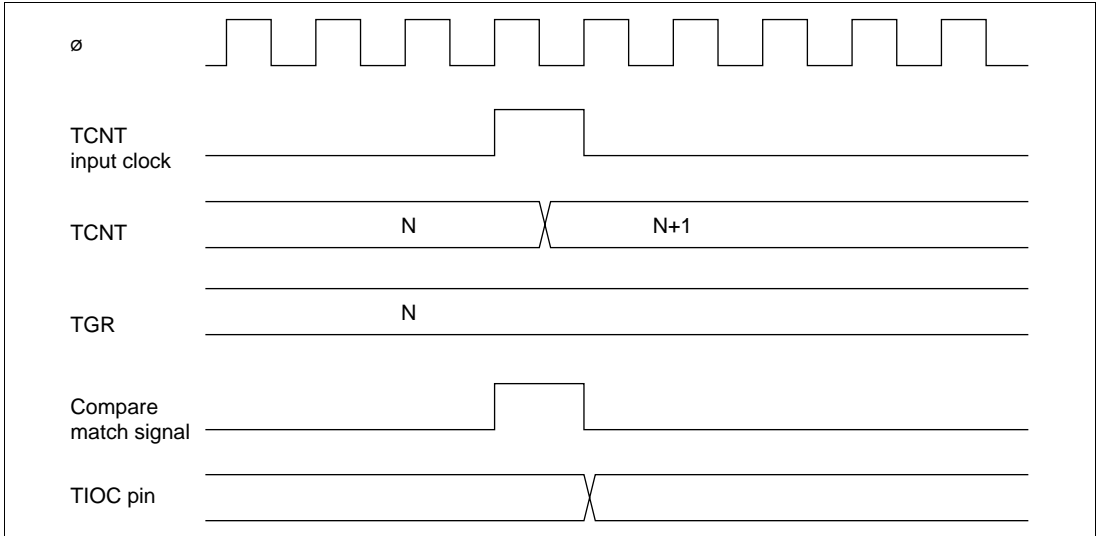
**Figure 10.31 Count Timing in Internal Clock Operation**



**Figure 10.32 Count Timing in External Clock Operation**

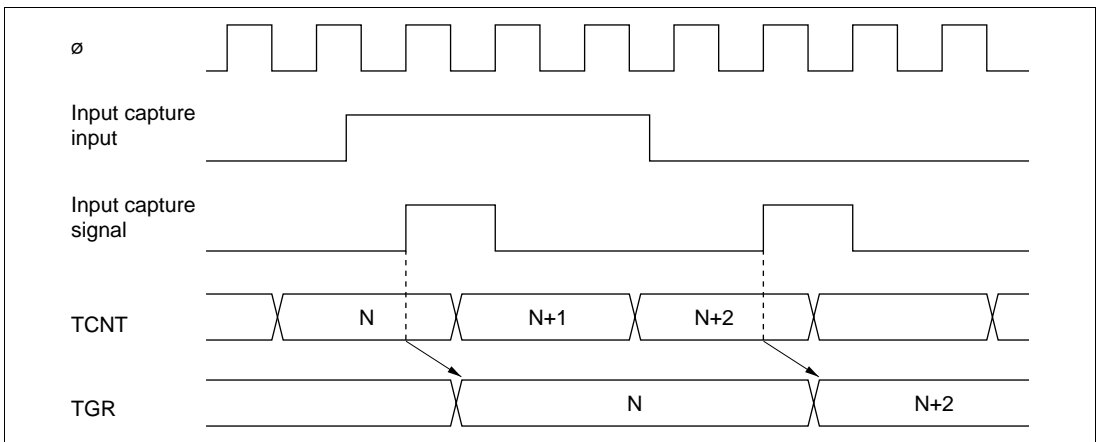
**Output Compare Output Timing:** A compare match signal is generated in the final state in which TCNT and TGR match (the point at which the count value matched by TCNT is updated). When a compare match signal is generated, the output value set in TIOR is output at the output compare output pin (TIOC pin). After a match between TCNT and TGR, the compare match signal is not generated until the TCNT input clock is generated.

Figure 10.33 shows output compare output timing.



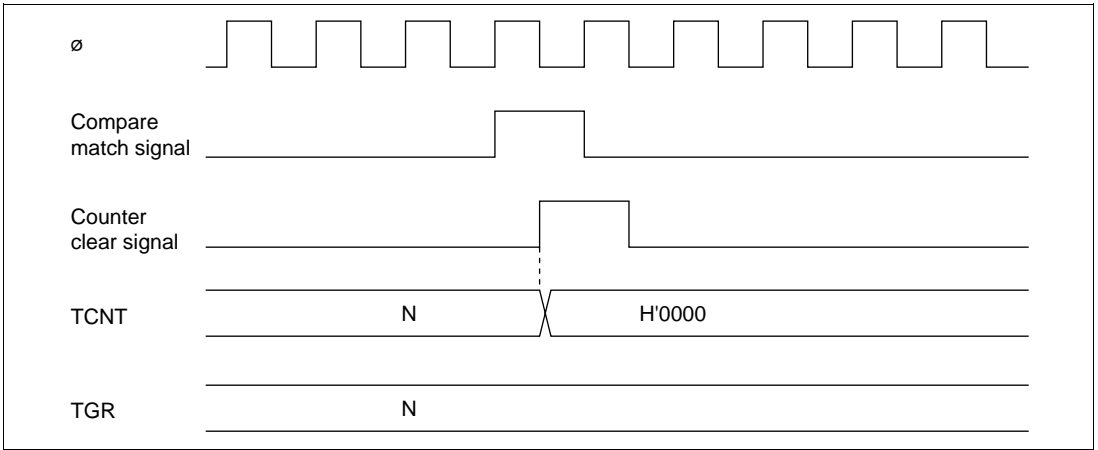
**Figure 10.33 Output Compare Output Timing**

**Input Capture Signal Timing:** Figure 10.34 shows input capture signal timing.

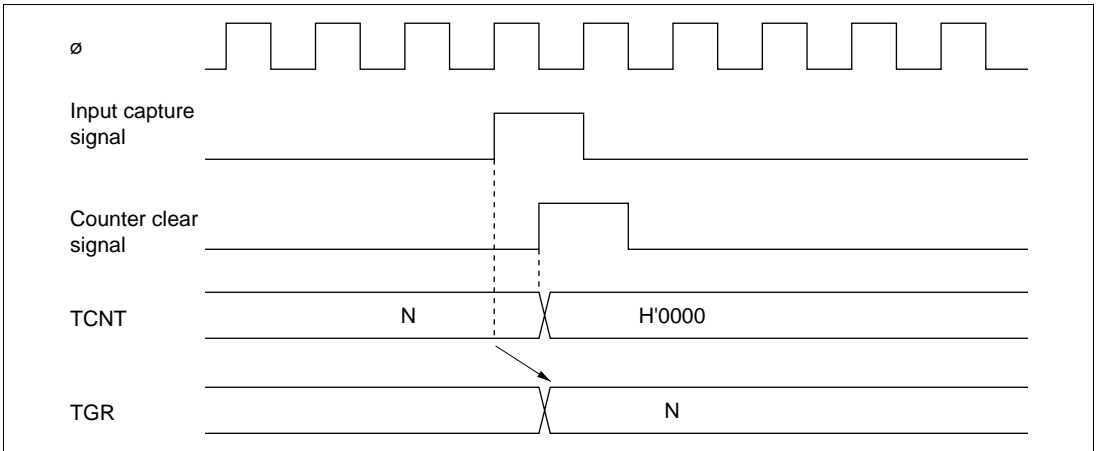


**Figure 10.34 Input Capture Input Signal Timing**

**Timing for Counter Clearing by Compare Match/Input Capture:** Figure 10.35 shows the timing when counter clearing by compare match occurrence is specified, and figure 10.36 shows the timing when counter clearing by input capture occurrence is specified.

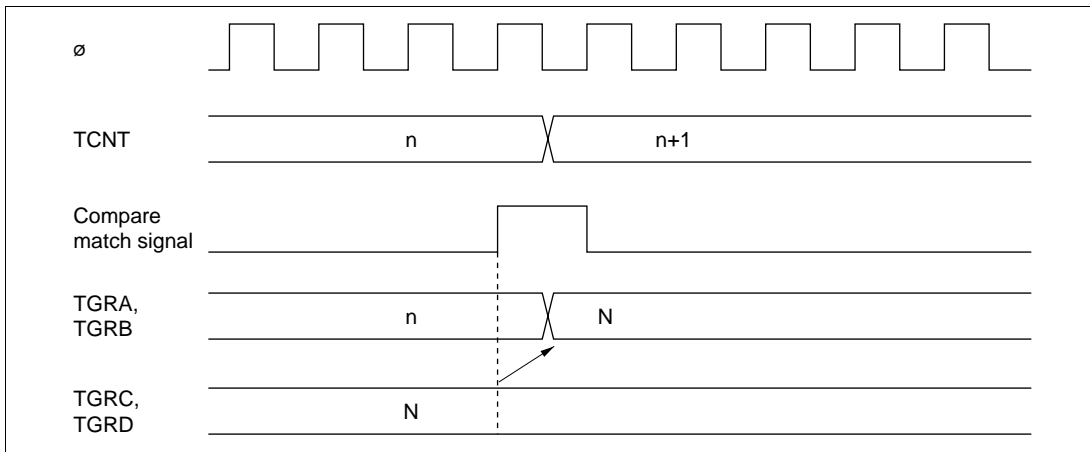


**Figure 10.35 Counter Clear Timing (Compare Match)**

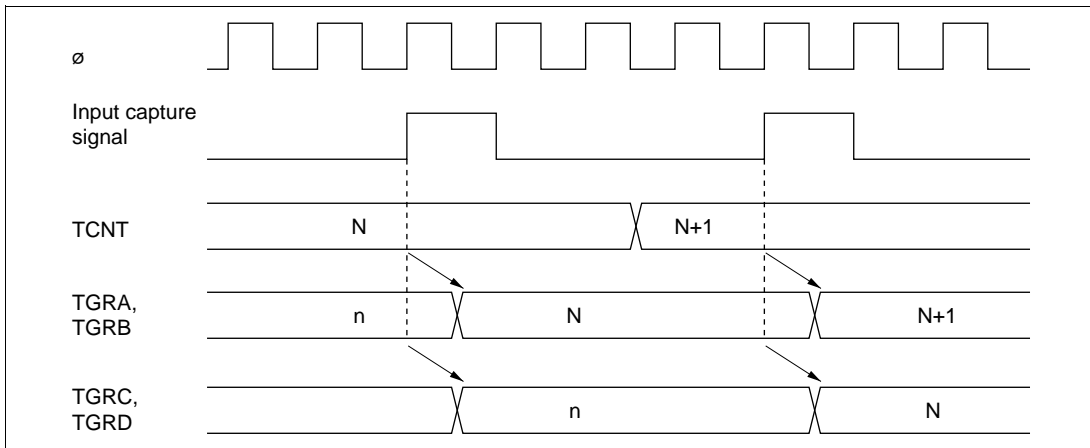


**Figure 10.36 Counter Clear Timing (Input Capture)**

**Buffer Operation Timing:** Figures 10.37 and 10.38 show the timing in buffer operation.



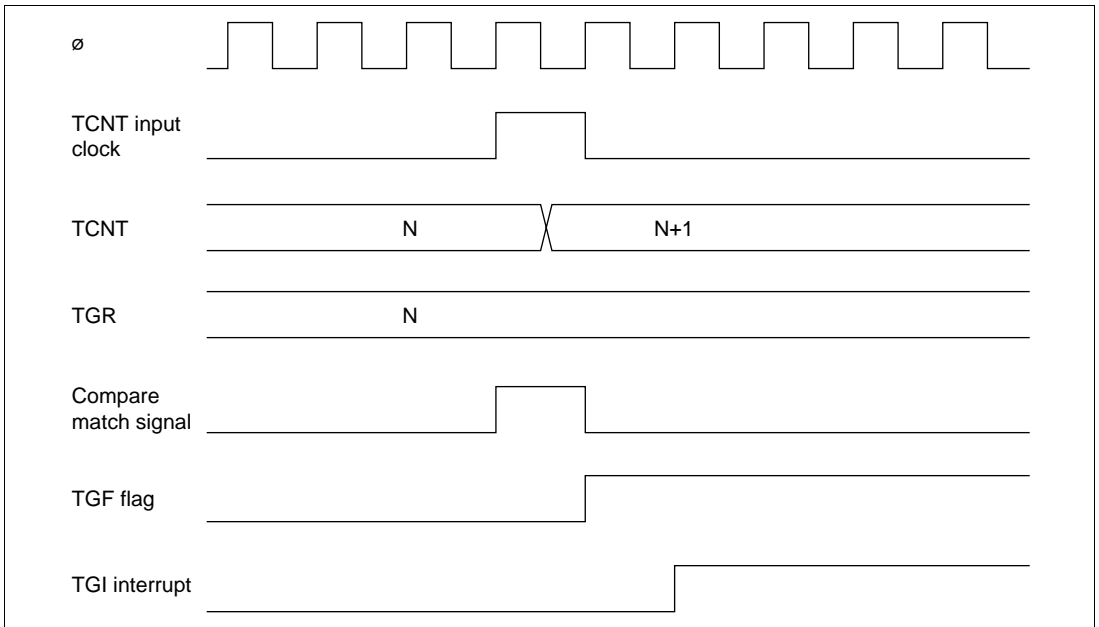
**Figure 10.37 Buffer Operation Timing (Compare Match)**



**Figure 10.38 Buffer Operation Timing (Input Capture)**

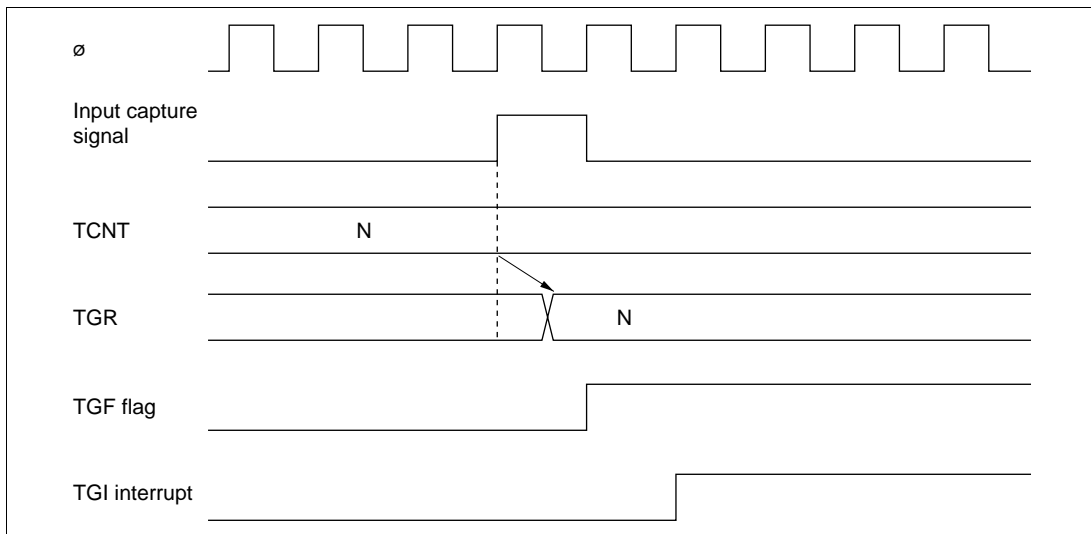
## 10.6.2 Interrupt Signal Timing

**TGF Flag Setting Timing in Case of Compare Match:** Figure 10.39 shows the timing for setting of the TGF flag in TSR by compare match occurrence, and TGI interrupt request signal timing.



**Figure 10.39 TGI Interrupt Timing (Compare Match)**

**TGF Flag Setting Timing in Case of Input Capture:** Figure 10.40 shows the timing for setting of the TGF flag in TSR by input capture occurrence, and TGI interrupt request signal timing.

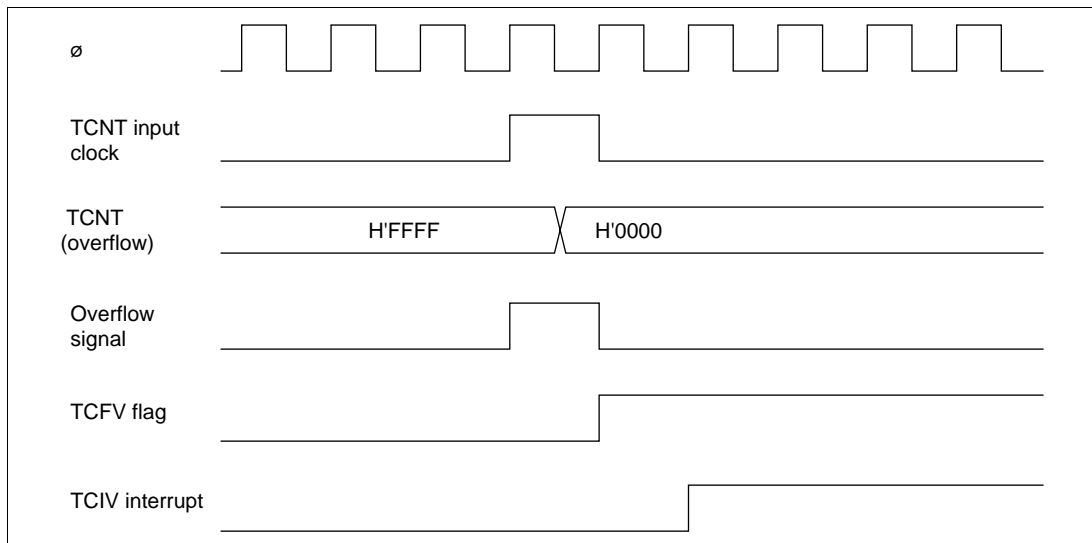


**Figure 10.40 TGI Interrupt Timing (Input Capture)**

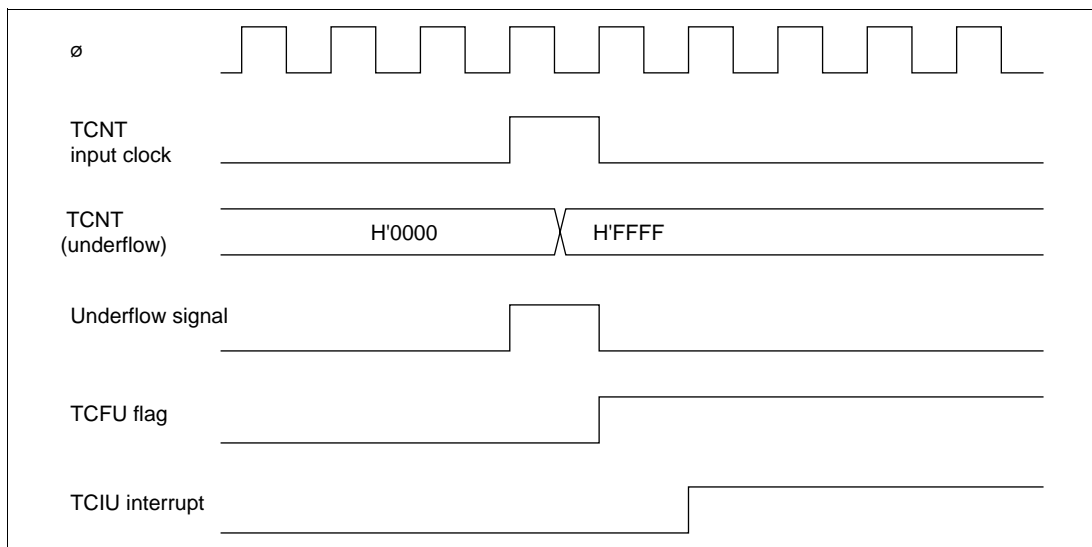


**TCFV Flag/TCFU Flag Setting Timing:** Figure 10.41 shows the timing for setting of the TCFV flag in TSR by overflow occurrence, and TCIV interrupt request signal timing.

Figure 10.42 shows the timing for setting of the TCFU flag in TSR by underflow occurrence, and TCIU interrupt request signal timing.

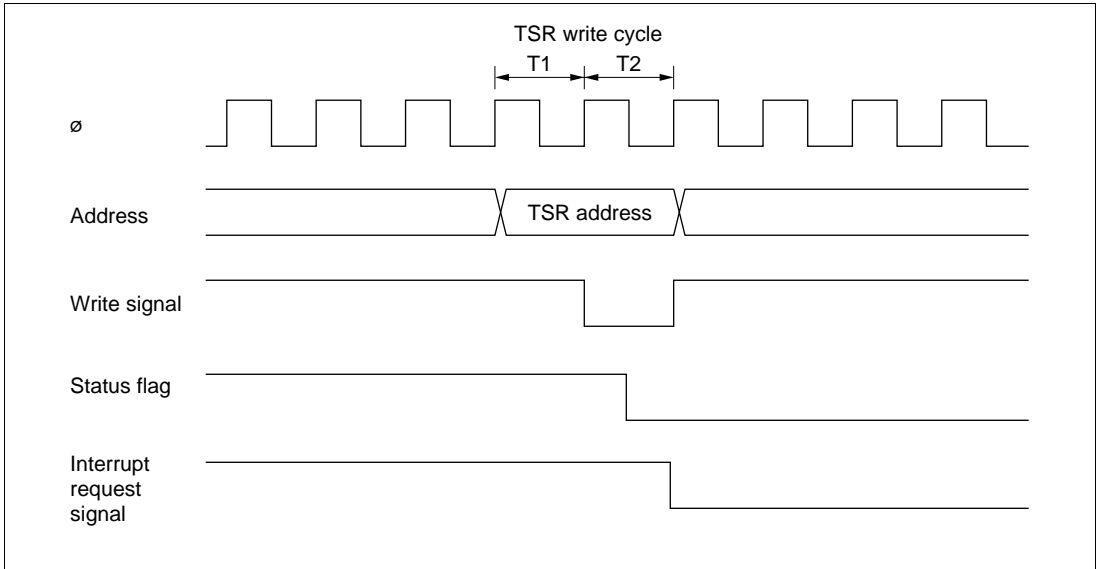


**Figure 10.41 TCIV Interrupt Setting Timing**

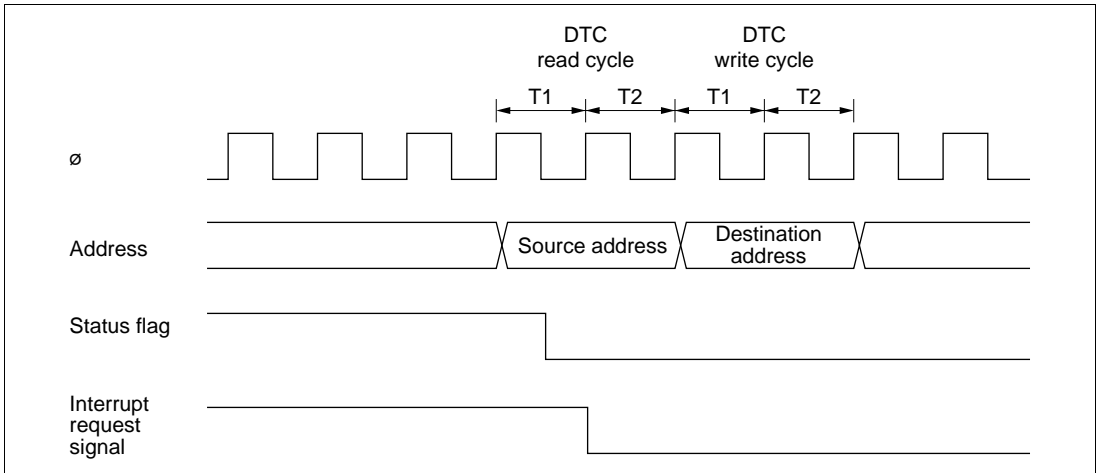


**Figure 10.42 TCIU Interrupt Setting Timing**

**Status Flag Clearing Timing:** After a status flag is read as 1 by the CPU, it is cleared by writing 0 to it. When the DTC is activated, the flag is cleared automatically. Figure 10.43 shows the timing for status flag clearing by the CPU, and figure 10.44 shows the timing for status flag clearing by the DTC.



**Figure 10.43 Timing for Status Flag Clearing by CPU**



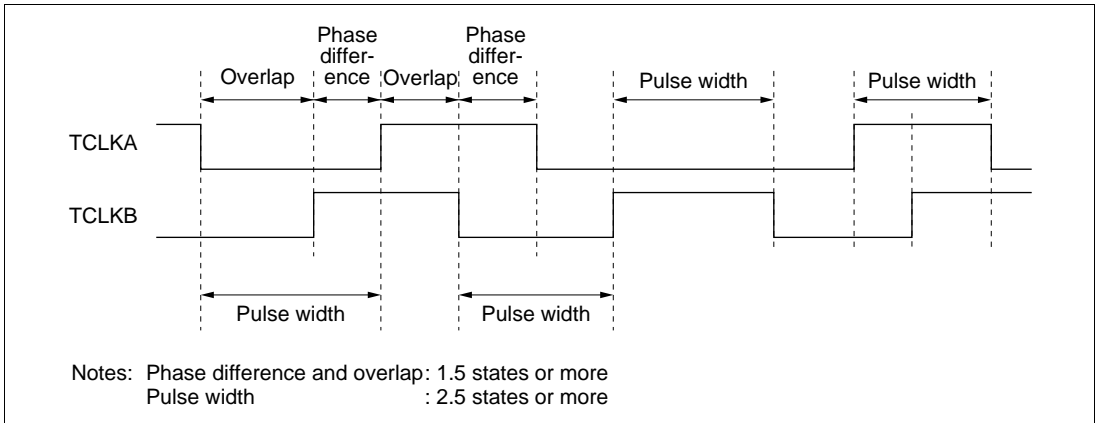
**Figure 10.44 Timing for Status Flag Clearing by DTC Activation**

## 10.7 Usage Notes

Note that the kinds of operation and contention described below occur during TPU operation.

**Input Clock Restrictions:** The input clock pulse width must be at least 1.5 states in the case of single-edge detection, and at least 2.5 states in the case of both-edge detection. The TPU will not operate properly with a narrower pulse width.

In phase counting mode, the phase difference and overlap between the two input clocks must be at least 1.5 states, and the pulse width must be at least 2.5 states. Figure 10.45 shows the input clock conditions in phase counting mode.



**Figure 10.45 Phase Difference, Overlap, and Pulse Width in Phase Counting Mode**

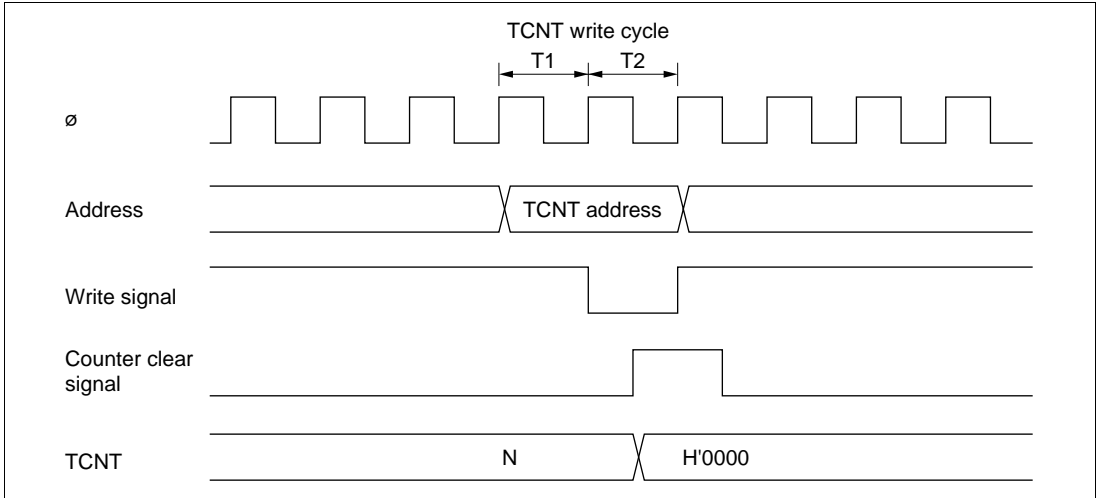
**Caution on Period Setting:** When counter clearing by compare match is set, TCNT is cleared in the final state in which it matches the TGR value (the point at which the count value matched by TCNT is updated). Consequently, the actual counter frequency is given by the following formula:

$$f = \frac{\phi}{(N + 1)}$$

Where  $f$  : Counter frequency  
 $\phi$  : Operating frequency  
 $N$  : TGR set value

**Contention between TCNT Write and Clear Operations:** If the counter clear signal is generated in the T2 state of a TCNT write cycle, TCNT clearing takes precedence and the TCNT write is not performed.

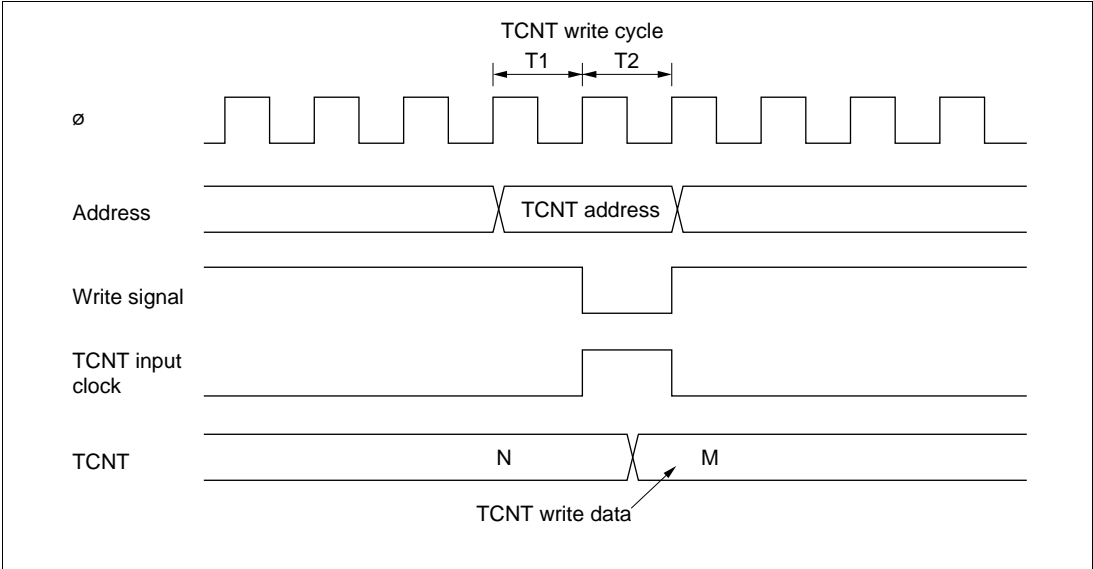
Figure 10.46 shows the timing in this case.



**Figure 10.46 Contention between TCNT Write and Clear Operations**

**Contention between TCNT Write and Increment Operations:** If incrementing occurs in the T2 state of a TCNT write cycle, the TCNT write takes precedence and TCNT is not incremented.

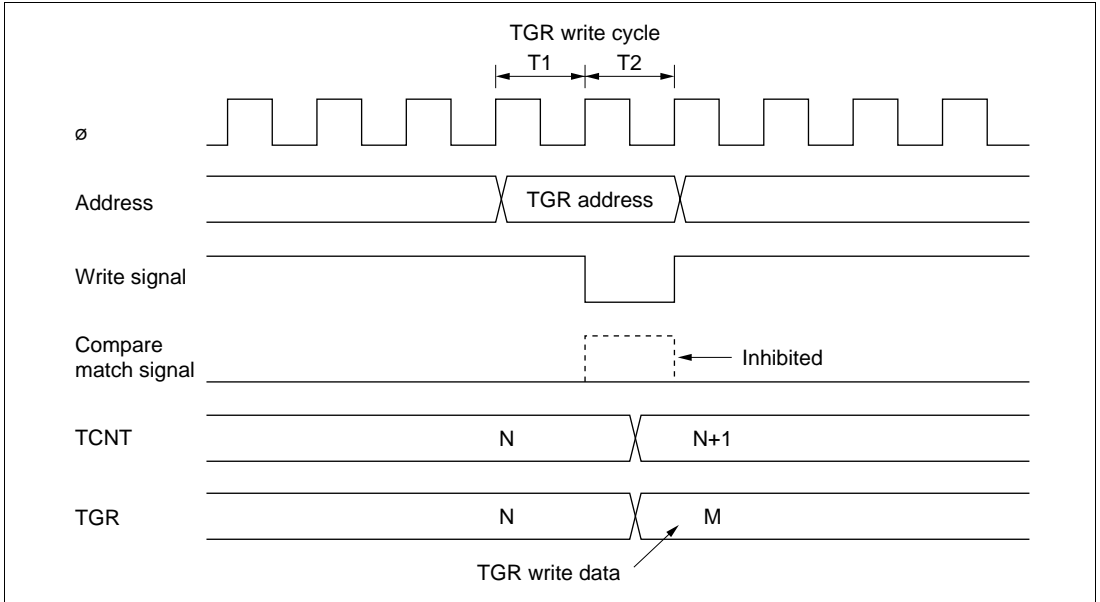
Figure 10.47 shows the timing in this case.



**Figure 10.47** Contention between TCNT Write and Increment Operations

**Contention between TGR Write and Compare Match:** If a compare match occurs in the T2 state of a TGR write cycle, the TGR write takes precedence and the compare match signal is inhibited. A compare match does not occur even if the same value as before is written.

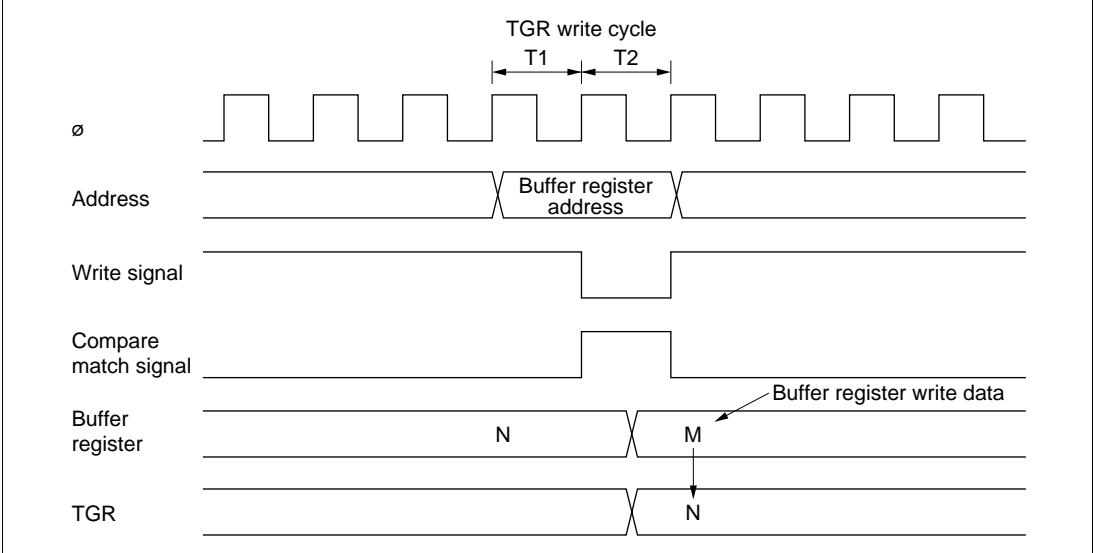
Figure 10.48 shows the timing in this case.



**Figure 10.48 Contention between TGR Write and Compare Match**

**Contention between Buffer Register Write and Compare Match:** If a compare match occurs in the T2 state of a TGR write cycle, the data transferred to TGR by the buffer operation will be the data prior to the write.

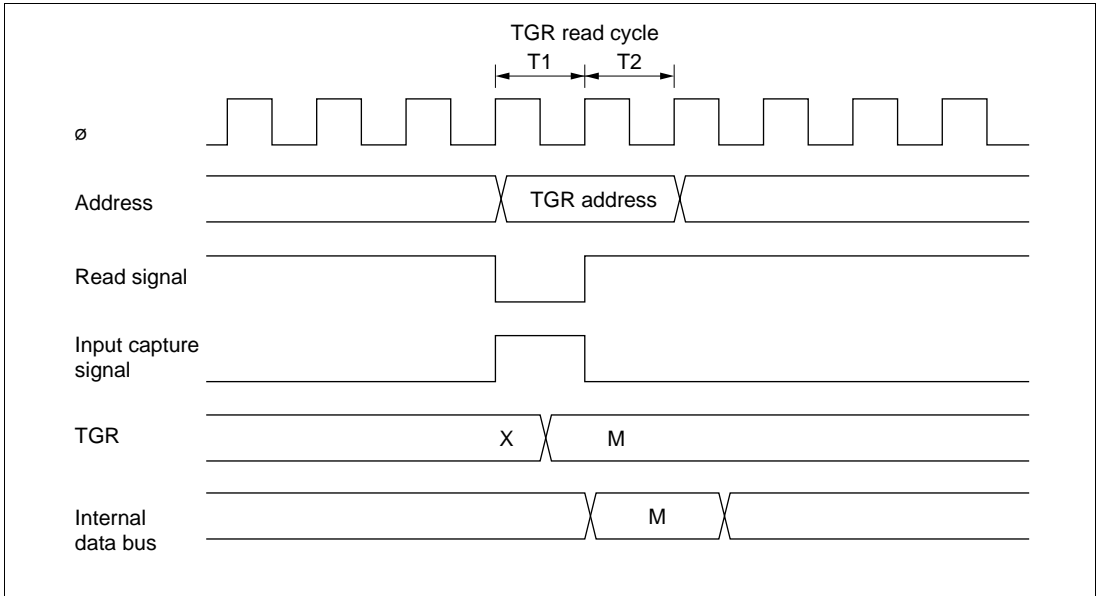
Figure 10.49 shows the timing in this case.



**Figure 10.49 Contention between Buffer Register Write and Compare Match**

**Contention between TGR Read and Input Capture:** If the input capture signal is generated in the T1 state of a TGR read cycle, the data that is read will be the data after input capture transfer.

Figure 10.50 shows the timing in this case.

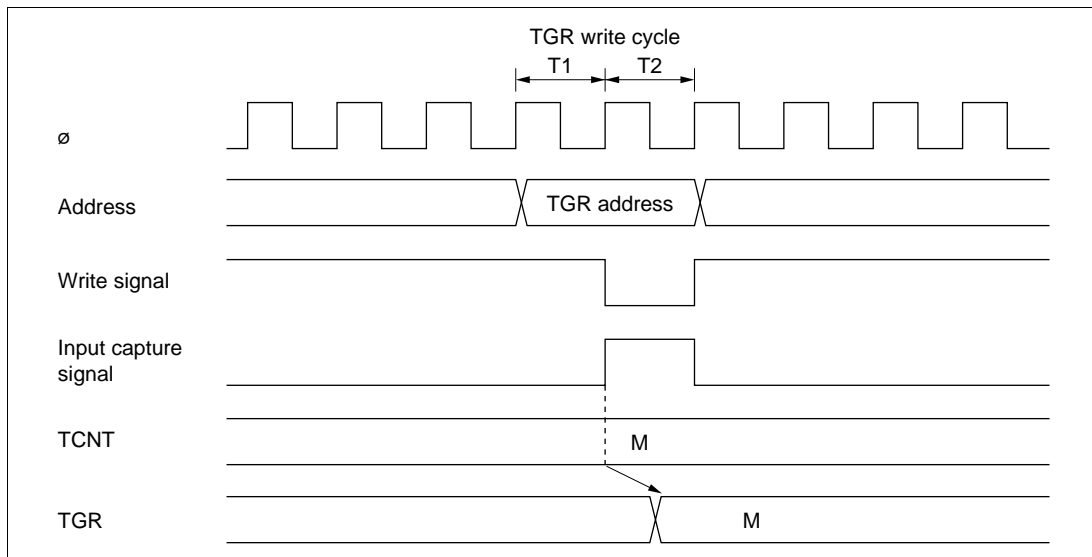


**Figure 10.50 Contention between TGR Read and Input Capture**



**Contention between TGR Write and Input Capture:** If the input capture signal is generated in the T2 state of a TGR write cycle, the input capture operation takes precedence and the write to TGR is not performed.

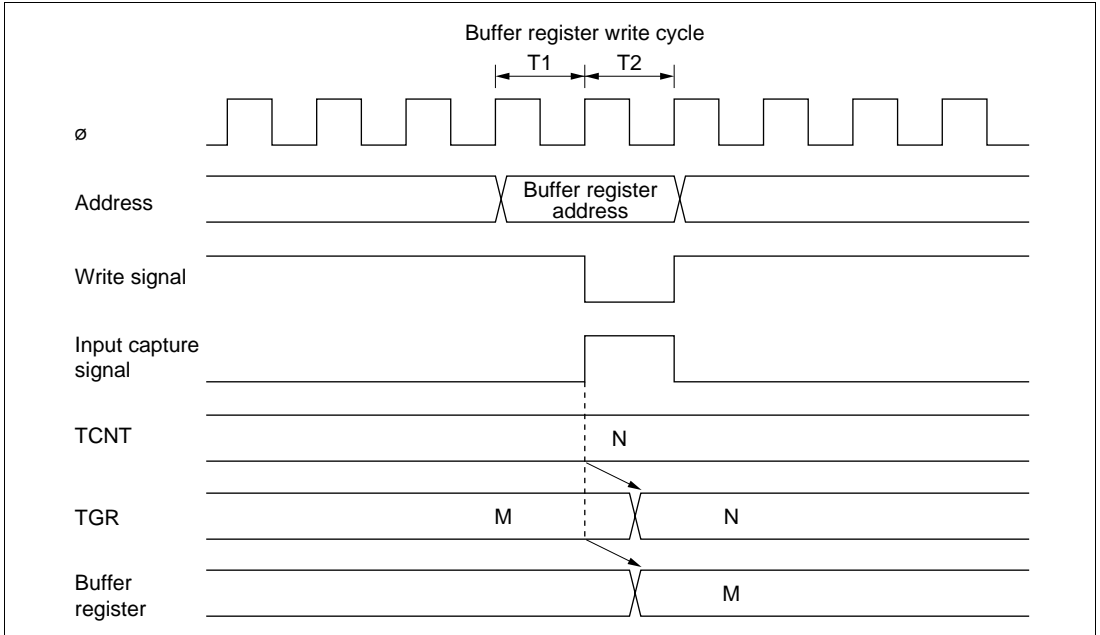
Figure 10.51 shows the timing in this case.



**Figure 10.51 Contention between TGR Write and Input Capture**

**Contention between Buffer Register Write and Input Capture:** If the input capture signal is generated in the T2 state of a buffer write cycle, the buffer operation takes precedence and the write to the buffer register is not performed.

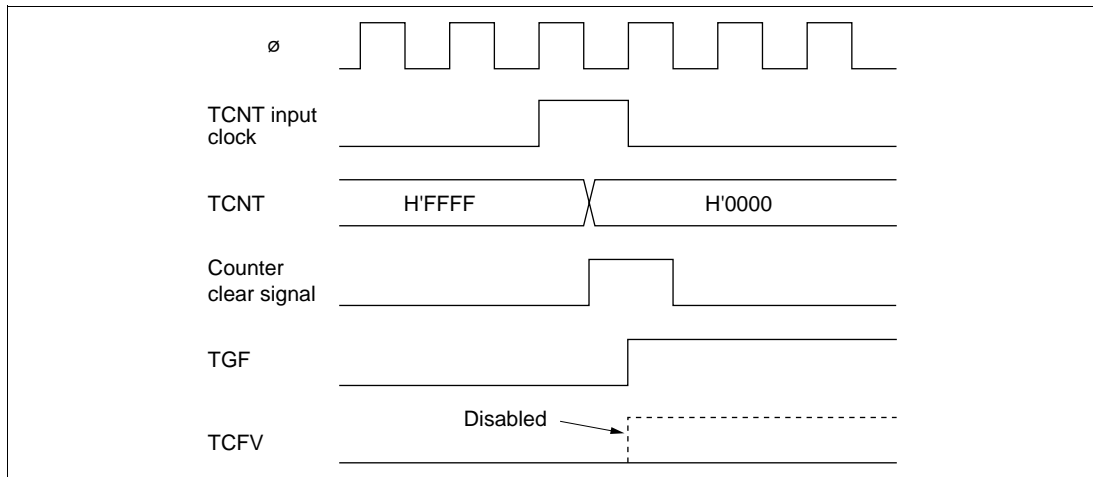
Figure 10.52 shows the timing in this case.



**Figure 10.52 Contention between Buffer Register Write and Input Capture**

**Contention between Overflow/Underflow and Counter Clearing:** If overflow/underflow and counter clearing occur simultaneously, the TCFV/TCFU flag in TSR is not set and TCNT clearing takes precedence.

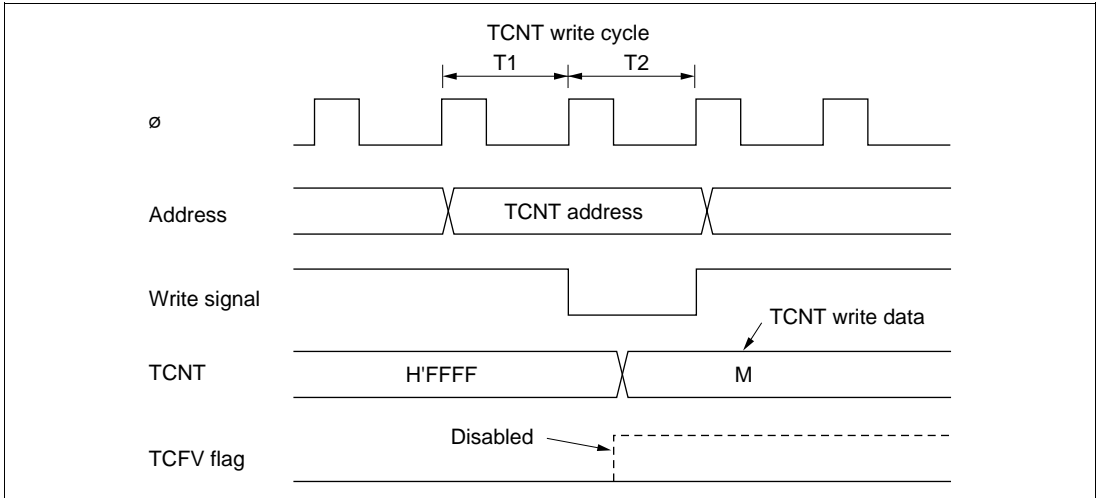
Figure 10.53 shows the operation timing when a TGR compare match is specified as the clearing source, and H'FFFF is set in TGR.



**Figure 10.53** Contention between Overflow and Counter Clearing

**Contention between TCNT Write and Overflow/Underflow:** If there is an up-count or down-count in the T2 state of a TCNT write cycle, and overflow/underflow occurs, the TCNT write takes precedence and the TCFV/TCFU flag in TSR is not set .

Figure 10.54 shows the operation timing when there is contention between TCNT write and overflow.



**Figure 10.54 Contention between TCNT Write and Overflow**

**Multiplexing of I/O Pins:** In the LSI, the TCLKA input pin is multiplexed with the TIOCC0 I/O pin and the TCLKB input pin with the TIOCD0 I/O pin. When an external clock is input, compare match output should not be performed from a multiplexed pin.

**Interrupts and Module Stop Mode:** If module stop mode is entered when an interrupt has been requested, it will not be possible to clear the CPU interrupt source or DTC activation source. Interrupts should therefore be disabled before entering module stop mode.

# Section 11 8-Bit Timers (TMR)

## 11.1 Overview

The LSI includes an 8-bit timer module with two channels (TMR0, TMR1). Each channel has an 8-bit counter (TCNT) and two time constant registers (TCORA and TCORB).

### 11.1.1 Features

The features of the 8-bit timer module are listed below.

- Selection of three clock sources
  - The counters can be driven by one of three internal clock signals ( $\phi/8$ ,  $\phi/64$ , or  $\phi/8192$ ).
- Selection of two ways to clear the counters
  - The counters can be cleared on compare match A or B.
- Provision for cascading of two channels
  - Operation as a 16-bit timer is possible, using channel 0 for the upper 8 bits and channel 1 for the lower 8 bits (16-bit count mode).
  - Channel 1 can be used to count channel 0 compare matches (compare match count mode).
- Three independent interrupts
  - Compare match A and B and overflow interrupts can be requested independently.
- A/D converter conversion start trigger can be generated
  - Channel 0 compare match A signal can be used as an A/D converter conversion start trigger.
- Module stop mode can be set
  - As the initial setting, 8-bit timer operation is halted. Register access is enabled by exiting module stop mode.

## 11.1.2 Block Diagram

Figure 11.1 shows a block diagram of the 8-bit timer module in case of TMR0 and TMR1.

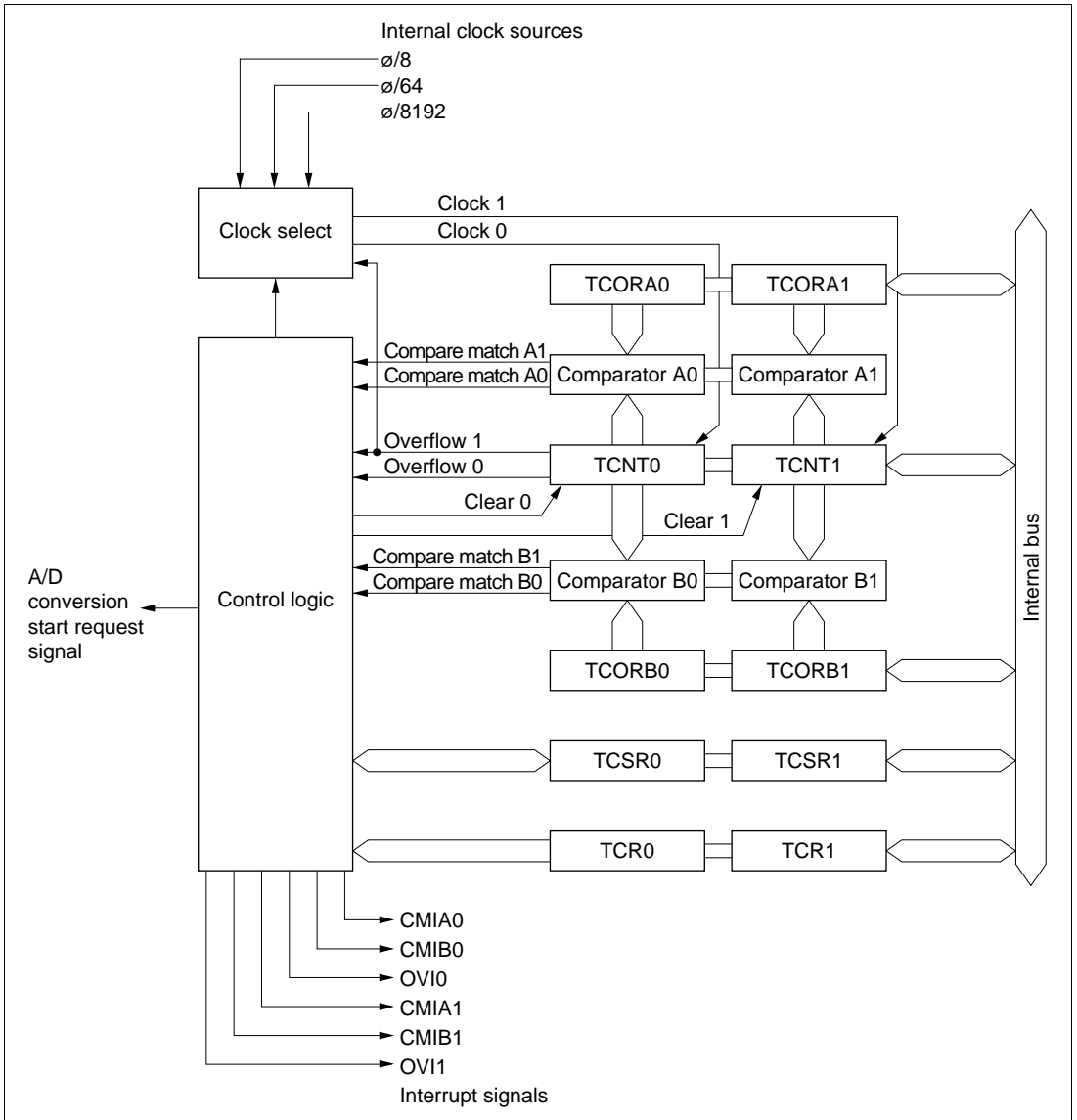


Figure 11.1 Block Diagram of 8-Bit Timer

### 11.1.3 Register Configuration

Table 11.1 summarizes the registers of the 8-bit timer module.

**Table 11.1 8-Bit Timer Registers**

Channel	Name	Abbreviation	R/W	Initial value	Address* <sup>1</sup>
0	Timer control register 0	TCR0	R/W	H'00	H'FF68
	Timer control/status register 0	TCSR0	R/(W)* <sup>2</sup>	H'00	H'FF6A
	Time constant register A0	TCORA0	R/W	H'FF	H'FF6C
	Time constant register B0	TCORB0	R/W	H'FF	H'FF6E
	Timer counter 0	TCNT0	R/W	H'00	H'FF70
1	Timer control register 1	TCR1	R/W	H'00	H'FF69
	Timer control/status register 1	TCSR1	R/(W)* <sup>2</sup>	H'10	H'FF6B
	Time constant register A1	TCORA1	R/W	H'FF	H'FF6D
	Time constant register B1	TCORB1	R/W	H'FF	H'FF6F
	Timer counter 1	TCNT1	R/W	H'00	H'FF71
Common	Module stop control register A	MSTPCRA	R/W	H'3F	H'FDE8

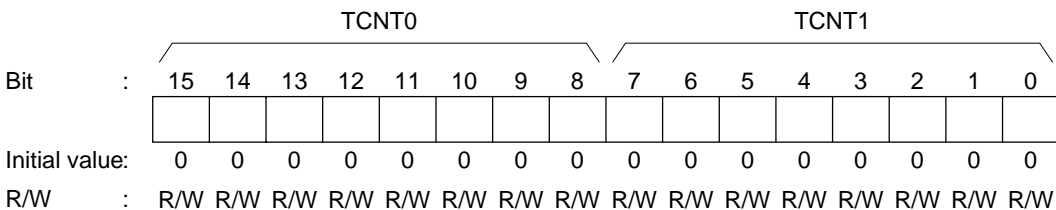
Notes: \*1 Lower 16 bits of the address

\*2 Only 0 can be written to bits 7 to 5, to clear these flags.

Each pair of registers for channel 0 and channel 1 is a 16-bit register with the upper 8 bits for channel 0 and the lower 8 bits for channel 1, so they can be accessed together by word transfer instruction.

## 11.2 Register Descriptions

### 11.2.1 Timer Counters 0 and 1 (TCNT0, TCNT1)



TCNT0 and TCNT1 are 8-bit readable/writable up-counters that increment on pulses generated from an internal or external clock source. This clock source is selected by clock select bits CKS2 to CKS0 of TCR. The CPU can read or write to TCNT0 and TCNT1 at all times.

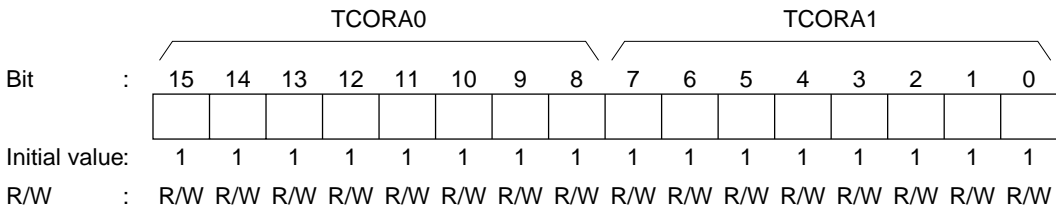
TCNT0 and TCNT1 comprise a single 16-bit register, so they can be accessed together by a word transfer instruction.

TCNT0 and TCNT1 can be cleared by a compare match signal. Which signal is to be used for clearing is selected by clock clear bits CCLR1 and CCLR0 of TCR.

When a timer counter overflows from H'FF to H'00, OVF in TCSR is set to 1.

TCNT0 and TCNT1 are each initialized to H'00 by a reset and in hardware standby mode.

### 11.2.2 Time Constant Registers A0 and A1 (TCORA0, TCORA1)



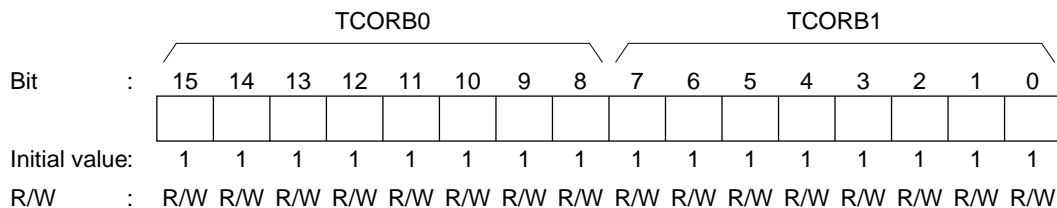
TCORA0 and TCORA1 are 8-bit readable/writable registers. TCORA0 and TCORA1 comprise a single 16-bit register so they can be accessed together by word transfer instruction.

TCORA is continually compared with the value in TCNT. When a match is detected, the corresponding CMFA flag in TCSR is set to 1. Note, however, that comparison is disabled during the T2 state of a TCOR write cycle.

TCORA0 and TCORA1 are each initialized to H'FF by a reset and in hardware standby mode.



### 11.2.3 Time Constant Registers B0 and B1 (TCORB0, TCORB1)

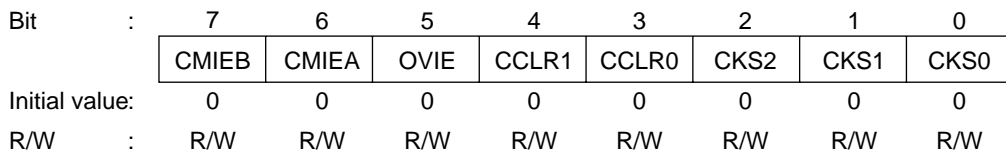


TCORB0 and TCORB1 are 8-bit readable/writable registers. TCORB0 and TCORB1 comprise a single 16-bit register so they can be accessed together by word transfer instruction.

TCORB is continually compared with the value in TCNT. When a match is detected, the corresponding CMFB flag in TCSR is set to 1. Note, however, that comparison is disabled during the T2 state of a TCOR write cycle.

TCORB0 and TCORB1 are each initialized to H'FF by a reset and in hardware standby mode.

### 11.2.4 Timer Control Registers 0 and 1 (TCR0, TCR1)



TCR0 and TCR1 are 8-bit readable/writable registers that select the input clock source and the time at which TCNT is cleared, and enable interrupts.

TCR0 and TCR1 are each initialized to H'00 by a reset and in hardware standby mode.

For details of this timing, see section 11.3, Operation.

**Bit 7—Compare Match Interrupt Enable B (CMIEB):** Selects whether CMFB interrupt requests (CMIB) are enabled or disabled when the CMFB flag of TCSR is set to 1.

**Bit 7**

CMIEB	Description
0	CMFB interrupt requests (CMIB) are disabled (Initial value)
1	CMFB interrupt requests (CMIB) are enabled

**Bit 6—Compare Match Interrupt Enable A (CMIEA):** Selects whether CMFA interrupt requests (CMIA) are enabled or disabled when the CMFA flag of TCSR is set to 1.

**Bit 6**

CMIEA	Description
0	CMFA interrupt requests (CMIA) are disabled (Initial value)
1	CMFA interrupt requests (CMIA) are enabled

**Bit 5—Timer Overflow Interrupt Enable (OVIE):** Selects whether OVF interrupt requests (OVI) are enabled or disabled when the OVF flag of TCSR is set to 1.

**Bit 5**

OVIE	Description
0	OVF interrupt requests (OVI) are disabled (Initial value)
1	OVF interrupt requests (OVI) are enabled

**Bits 4 and 3—Counter Clear 1 and 0 (CCLR1, CCLR0):** These bits select the method by which TCNT is cleared: by compare match A or B.

**Bit 4**

**Bit 3**

CCLR1	CCLR0	Description
0	0	Clear is disabled (Initial value)
	1	Clear by compare match A
1	0	Clear by compare match B
	1	Setting disabled

**Bits 2 to 0—Clock Select 2 to 0 (CKS2 to CKS0):** These bits select the clock input to TCNT is an internal clock.

Three internal clocks can be selected, all divided from the system clock ( $\phi$ ):  $\phi/8$ ,  $\phi/64$ , and  $\phi/8192$ . The falling edge of the selected internal clock triggers the count.

Some functions differ between channel 0 and channel 1.

Bit 2	Bit 1	Bit 0	Description
CKS2	CKS1	CKS0	
0	0	0	Clock input disabled (Initial value)
		1	Internal clock, counted at falling edge of $\phi/8$
	1	0	Internal clock, counted at falling edge of $\phi/64$
		1	Internal clock, counted at falling edge of $\phi/8192$
1	0	0	For channel 0: count at TCNT1 overflow signal* For channel 1: count at TCNT0 compare match A*
		1	Setting disabled
	1	0	Setting disabled
		1	Setting disabled

Note: \* If the count input of channel 0 is the TCNT1 overflow signal and that of channel 1 is the TCNT0 compare match signal, no incrementing clock is generated. Do not use this setting.

## 11.2.5 Timer Control/Status Registers 0 and 1 (TCSR0, TCSR1)

### TCSR0

Bit	:	7	6	5	4	3	2	1	0
		CMFB	CMFA	OVF	ADTE	—	—	—	—
Initial value :		0	0	0	0	0	0	0	0
R/W	:	R/(W)*	R/(W)*	R/(W)*	R/W	R/W	R/W	R/W	R/W

### TCSR1

Bit	:	7	6	5	4	3	2	1	0
		CMFB	CMFA	OVF	—	—	—	—	—
Initial value :		0	0	0	1	0	0	0	0
R/W	:	R/(W)*	R/(W)*	R/(W)*	—	R/W	R/W	R/W	R/W

Note: \* Only 0 can be written to bits 7 to 5, to clear these flags.

TCSR0 and TCSR1 are 8-bit registers that display compare match and overflow statuses, and control compare match output.

TCSR0 is initialized to H'00, and TCSR1 to H'10, by a reset and in hardware standby mode.

**Bit 7—Compare Match Flag B (CMFB):** Status flag indicating whether the values of TCNT and TCORB match.

#### Bit 7

CMFB	Description
0	[Clearing conditions] (Initial value) <ul style="list-style-type: none"> <li>• Cleared by reading CMFB when CMFB = 1, then writing 0 to CMFB</li> <li>• When DTC is activated by CMIB interrupt while DISEL bit of MRB in DTC is 0</li> </ul>
1	[Setting condition] Set when TCNT matches TCORB

**Bit 6—Compare Match Flag A (CMFA):** Status flag indicating whether the values of TCNT and TCORA match.

**Bit 6**

CMFA	Description
0	[Clearing conditions] (Initial value) <ul style="list-style-type: none"><li>• Cleared by reading CMFA when CMFA = 1, then writing 0 to CMFA</li><li>• When DTC is activated by CMIA interrupt while DISEL bit of MRB in DTC is 0</li></ul>
1	[Setting condition] Set when TCNT matches TCORA

**Bit 5—Timer Overflow Flag (OVF):** Status flag indicating that TCNT has overflowed (changed from H'FF to H'00).

**Bit 5**

OVF	Description
0	[Clearing condition] (Initial value) Cleared by reading OVF when OVF = 1, then writing 0 to OVF
1	[Setting condition] Set when TCNT overflows from H'FF to H'00

**Bit 4—A/D Trigger Enable (ADTE) (TCSR0 Only):** Selects enabling or disabling of A/D converter start requests by compare-match A.

TCSR1 is reserved bit. When TCSR1 is read, always 1 is read off. It cannot be modified.

**Bit 4**

ADTE	Description
0	A/D converter start requests by compare match A are disabled (Initial value)
1	A/D converter start requests by compare match A are enabled

**Bits 3 to 0—Reserved:** Only 0 may be written to these bits.

## 11.2.6 Module Stop Control Register A (MSTPCRA)

Bit	:	7	6	5	4	3	2	1	0
		MSTPA7	MSTPA6	MSTPA5	MSTPA4	MSTPA3	MSTPA2	MSTPA1	MSTPA0
Initial value	:	0	0	1	1	1	1	1	1
R/W	:	R/W	R/W	R/W	R/W	R/W	R/W	R/W	R/W

MSTPCRA is an 8-bit readable/writable register that performs module stop mode control.

When the MSTPA4 bit in MSTPCRA is set to 1, the 8-bit timer operation stops at the end of the bus cycle and a transition is made to module stop mode. For details, see section 21.5, Module Stop Mode.

MSTPCRA is initialized to H'3F by a reset and in hardware standby mode. It is not initialized in software standby mode.

**Bit 4—Module Stop (MSTPA4):** Specifies the TMR0 and TMR1 module stop mode.

### Bit 4

MSTPA4	Description
0	TMR0, TMR1 module stop mode cleared
1	TMR0, TMR1 module stop mode set (Initial value)

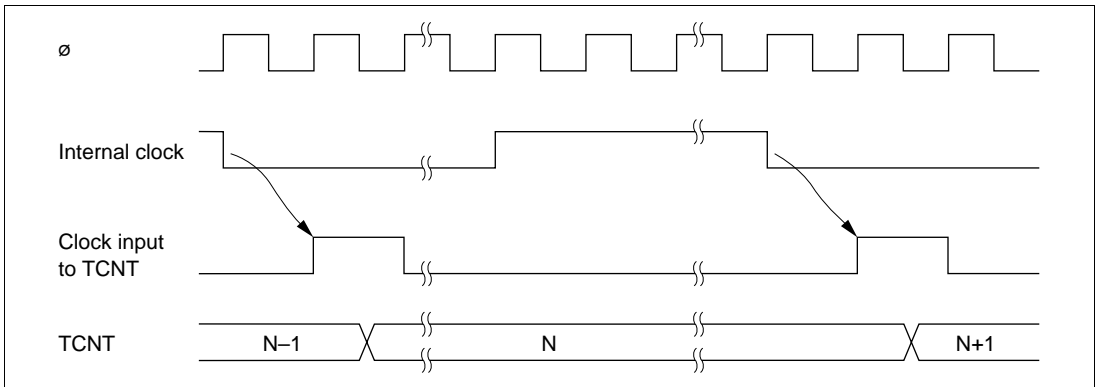
**Bit 0—Reserved:** Only 1 may be written to this bit.

## 11.3 Operation

### 11.3.1 TCNT Increment Timing

TCNT is incremented by input clock pulses.

**Internal Clock:** Three different internal clock signals ( $\phi/8$ ,  $\phi/64$ , or  $\phi/8192$ ) divided from the system clock ( $\phi$ ) can be selected, by setting bits CKS2 to CKS0 in TCR. Figure 11.2 shows the count timing.

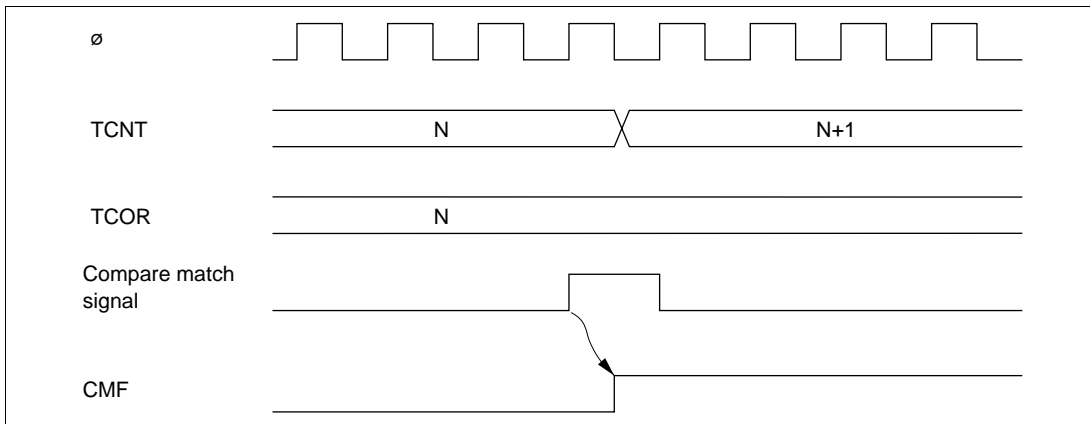


**Figure 11.2** Count Timing for Internal Clock Input

### 11.3.2 Compare Match Timing

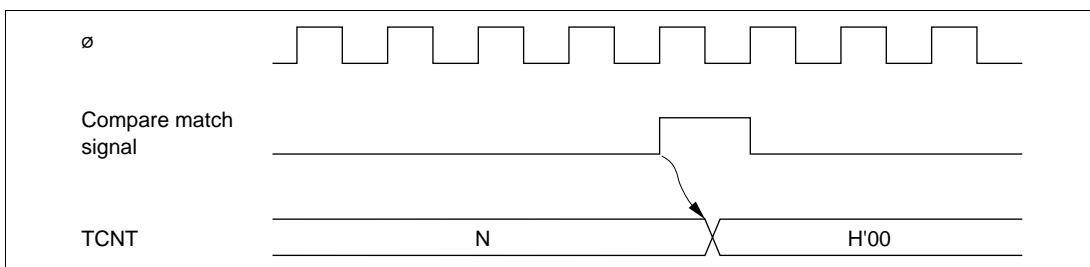
**Setting of Compare Match Flags A and B (CMFA, CMFB):** The CMFA and CMFB flags in TCSR are set to 1 by a compare match signal generated when the TCOR and TCNT values match. The compare match signal is generated at the last state in which the match is true, just before the timer counter is updated.

Therefore, when TCOR and TCNT match, the compare match signal is not generated until the next increment clock input. Figure 11.3 shows this timing.



**Figure 11.3 Timing of CMF Setting**

**Timing of Compare Match Clear:** The timer counter is cleared when compare match A or B occurs, depending on the setting of the CCLR1 and CCLR0 bits in TCR. Figure 11.4 shows the timing of this operation.



**Figure 11.4 Timing of Compare Match Clear**



### 11.3.3 Timing of Overflow Flag (OVF) Setting

The OVF in TCSR is set to 1 when the timer count overflows (changes from H'FF to H'00). Figure 11.5 shows the timing of this operation.

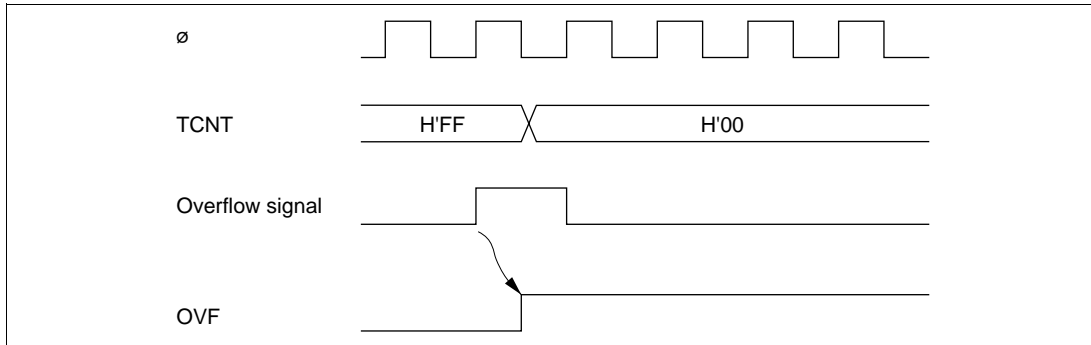


Figure 11.5 Timing of OVF Setting

### 11.3.4 Operation with Cascaded Connection

If bits CKS2 to CKS0 in either TCR0 or TCR1 are set to B'100, the 8-bit timers of the two channels are cascaded. With this configuration, a single 16-bit timer could be used (16-bit timer mode) or compare matches of the 8-bit timer channel 0 could be counted by the timer of channel 1 (compare match counter mode). In this case, the timer operates as below.

**16-Bit Counter Mode:** When bits CKS2 to CKS0 in TCR0 are set to B'100, the timer functions as a single 16-bit timer with channel 0 occupying the upper 8 bits and channel 1 occupying the lower 8 bits.

- Setting of compare match flags
  - The CMF flag in TCSR0 is set to 1 when a 16-bit compare match event occurs.
  - The CMF flag in TCSR1 is set to 1 when a lower 8-bit compare match event occurs.
- Counter clear specification
  - If the CCLR1 and CCLR0 bits in TCR0 have been set for counter clear at compare match, the 16-bit counter (TCNT0 and TCNT1 together) is cleared when a 16-bit compare match event occurs.
  - The settings of the CCLR1 and CCLR0 bits in TCR1 are ignored. The lower 8 bits cannot be cleared independently.

**Compare Match Counter Mode:** When bits CKS2 to CKS0 in TCR1 are B'100, TCNT1 counts compare match A's for channel 0.

Channels 0 and 1 are controlled independently. Conditions such as setting of the CMF flag, generation of interrupts, and counter clear are in accordance with the settings for each channel.

**Note on Usage:** If the 16-bit counter mode and compare match counter mode are set simultaneously, the input clock pulses for TCNT0 and TCNT1 are not generated and thus the counters will stop operating. Software should therefore avoid using both these modes.

## 11.4 Interrupts

### 11.4.1 Interrupt Sources and DTC Activation

There are three 8-bit timer interrupt sources: CMIA, CMIB, and OVI. Their relative priorities are shown in Table 11.2. Each interrupt source is set as enabled or disabled by the corresponding interrupt enable bit in TCR, and independent interrupt requests are sent for each to the interrupt controller. It is also possible to activate the DTC by means of CMIA and CMIB interrupts.

**Table 11.2 8-Bit Timer Interrupt Sources**

Channel	Interrupt Source	Description	DTC Activation	Priority
0	CMIA0	Interrupt by CMFA	Possible	High ↑ Low
	CMIB0	Interrupt by CMFB	Possible	
	OVI0	Interrupt by OVF	Not possible	
1	CMIA1	Interrupt by CMFA	Possible	
	CMIB1	Interrupt by CMFB	Possible	
	OVI1	Interrupt by OVF	Not possible	Low

Note: This table shows the initial state immediately after a reset. The relative channel priorities can be changed by the interrupt controller.

### 11.4.2 A/D Converter Activation

The A/D converter can be activated only by channel 0 compare match A.

If the ADTE bit in TCSR0 is set to 1 when the CMFA flag is set to 1 by the occurrence of channel 0 compare match A, a request to start A/D conversion is sent to the A/D converter. If the 8-bit timer conversion start trigger has been selected on the A/D converter side at this time, A/D conversion is started.

## 11.5 Sample Application

In the example below, the 8-bit timer is used to specify the cycle for generating an interrupt, as shown in figure 11.6. The control bits are set as follows:

- [1] In TCR, bit CCLR1 is cleared to 0 and bit CCLR0 is set to 1 so that the timer counter is cleared when its value matches the constant in TCORA.
- [2] In TCR, bits CMIEB and CMIEA are set to 1 respectively, generating interrupts at TCORA and TCORB.

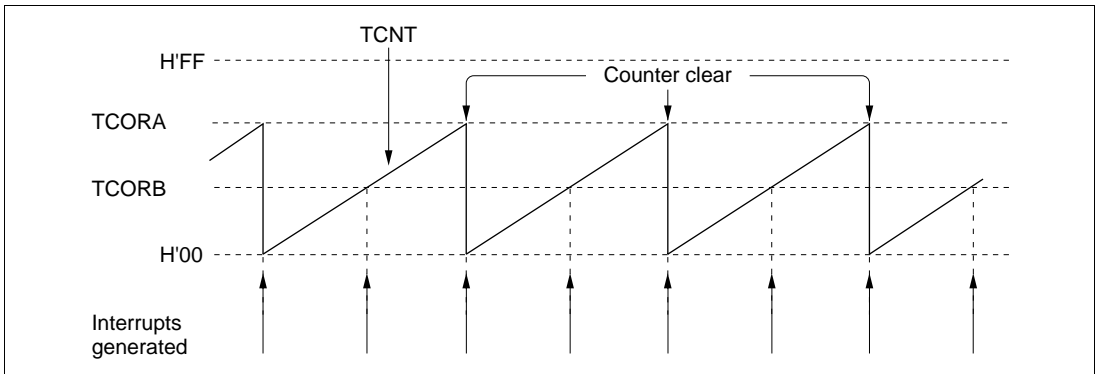


Figure 11.6 Example of Pulse Output

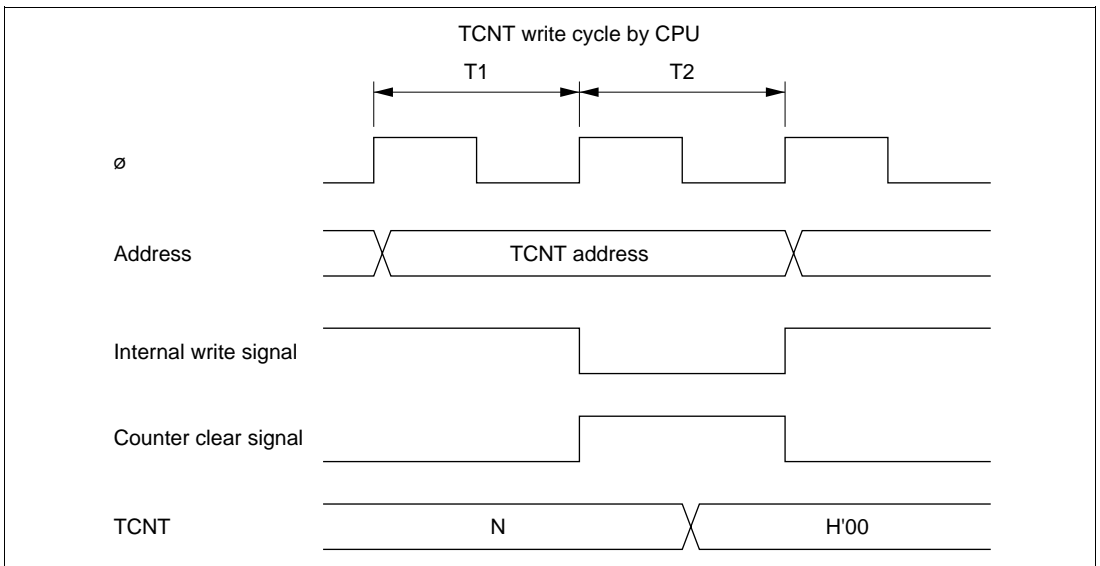
## 11.6 Usage Notes

Application programmers should note that the following kinds of contention can occur in the 8-bit timer.

### 11.6.1 Contention between TCNT Write and Clear

If a timer counter clock pulse is generated during the T2 state of a TCNT write cycle, the clear takes priority, so that the counter is cleared and the write is not performed.

Figure 11.7 shows this operation.

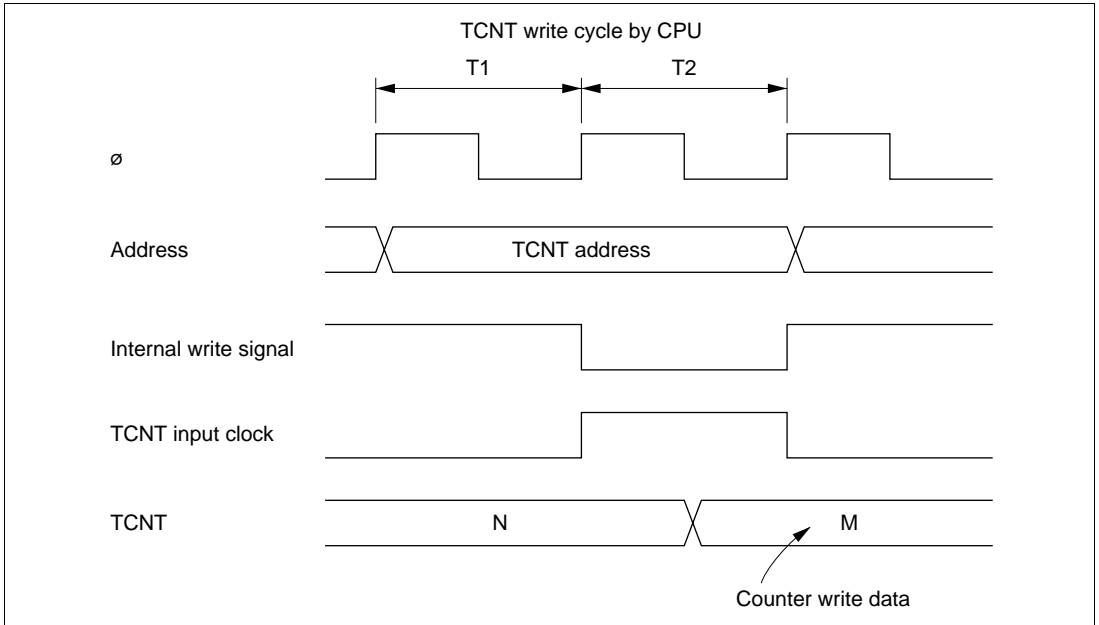


**Figure 11.7 Contention between TCNT Write and Clear**

## 11.6.2 Contention between TCNT Write and Increment

If a timer counter clock pulse is generated during the T2 state of a TCNT write cycle, the write takes priority and the counter is not incremented.

Figure 11.8 shows this operation.

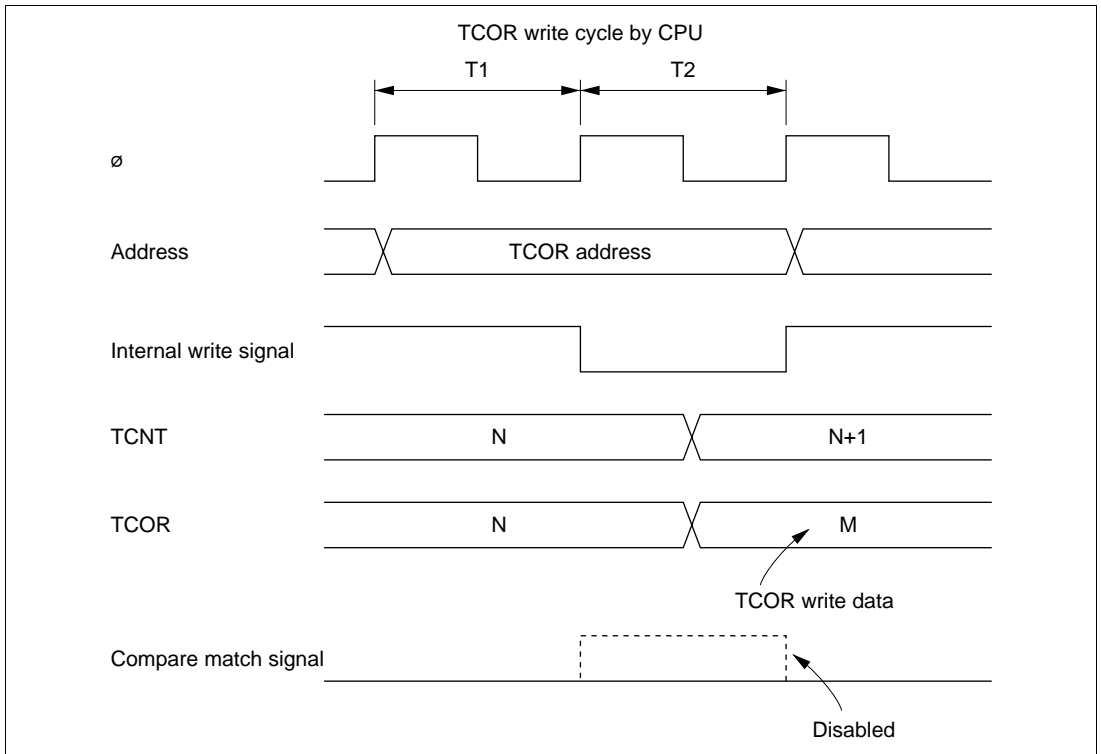


**Figure 11.8 Contention between TCNT Write and Increment**

### 11.6.3 Contention between TCOR Write and Compare Match

During the T2 state of a TCOR write cycle, the TCOR write has priority and the compare match signal is disabled even if a compare match event occurs.

Figure 11.9 shows this operation.



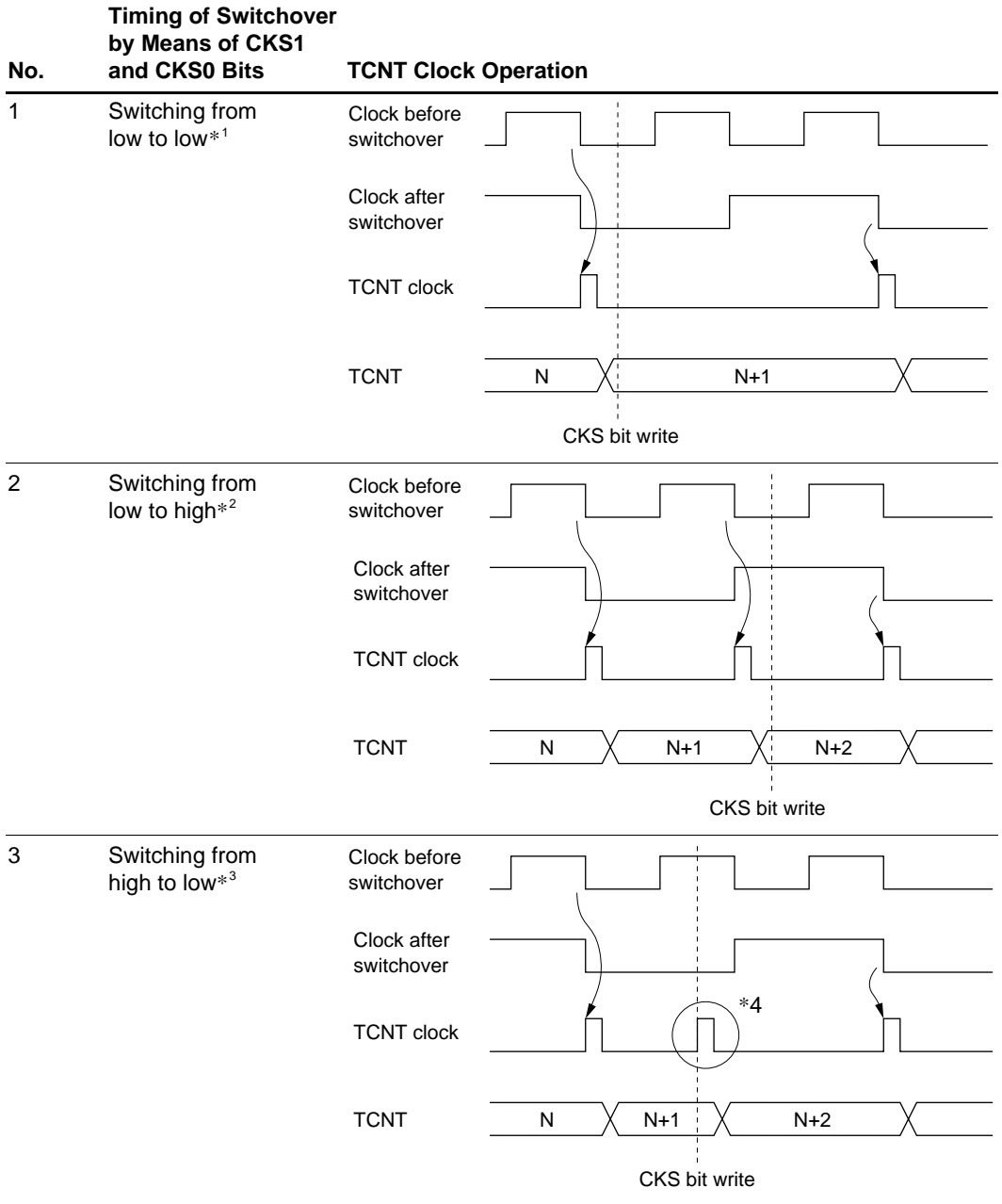
**Figure 11.9 Contention between TCOR Write and Compare Match**

### 11.6.4 Switching of Internal Clocks and TCNT Operation

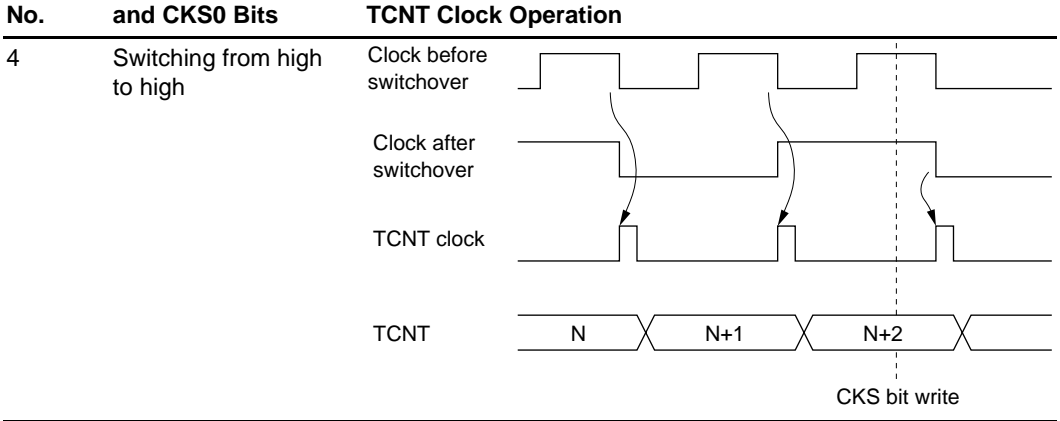
TCNT may increment erroneously when the internal clock is switched over. Table 11.3 shows the relationship between the timing at which the internal clock is switched (by writing to the CKS1 and CKS0 bits) and the TCNT operation.

When the TCNT clock is generated from an internal clock, the falling edge of the internal clock pulse is detected. If clock switching causes a change from high to low level, as shown in case 3 in table 11.3, a TCNT clock pulse is generated on the assumption that the switchover is a falling edge. This increments TCNT.

**Table 11.3 Switching of Internal Clock and TCNT Operation**



**Timing of Switchover  
by Means of CKS1  
and CKS0 Bits**



- Notes:
- \*1 Includes switching from low to stop, and from stop to low.
  - \*2 Includes switching from stop to high.
  - \*3 Includes switching from high to stop.
  - \*4 Generated on the assumption that the switchover is a falling edge; TCNT is incremented.

**11.6.5 Interrupts and Module Stop Mode**

If module stop mode is entered when an interrupt has been requested, it will not be possible to clear the CPU interrupt source or DTC activation source. Interrupts should therefore be disabled before entering module stop mode.



# Section 12 Watchdog Timer (WDT)

## 12.1 Overview

The LSI has an on-chip watchdog timer with two channels (WDT0 and WDT1). The watchdog timer can generate an internal reset signal if a system crash prevents the CPU from writing to the counter, allowing it to overflow.

When this watchdog function is not needed, the WDT can be used as an interval timer. In interval timer mode, an interval timer interrupt is generated each time the counter overflows.

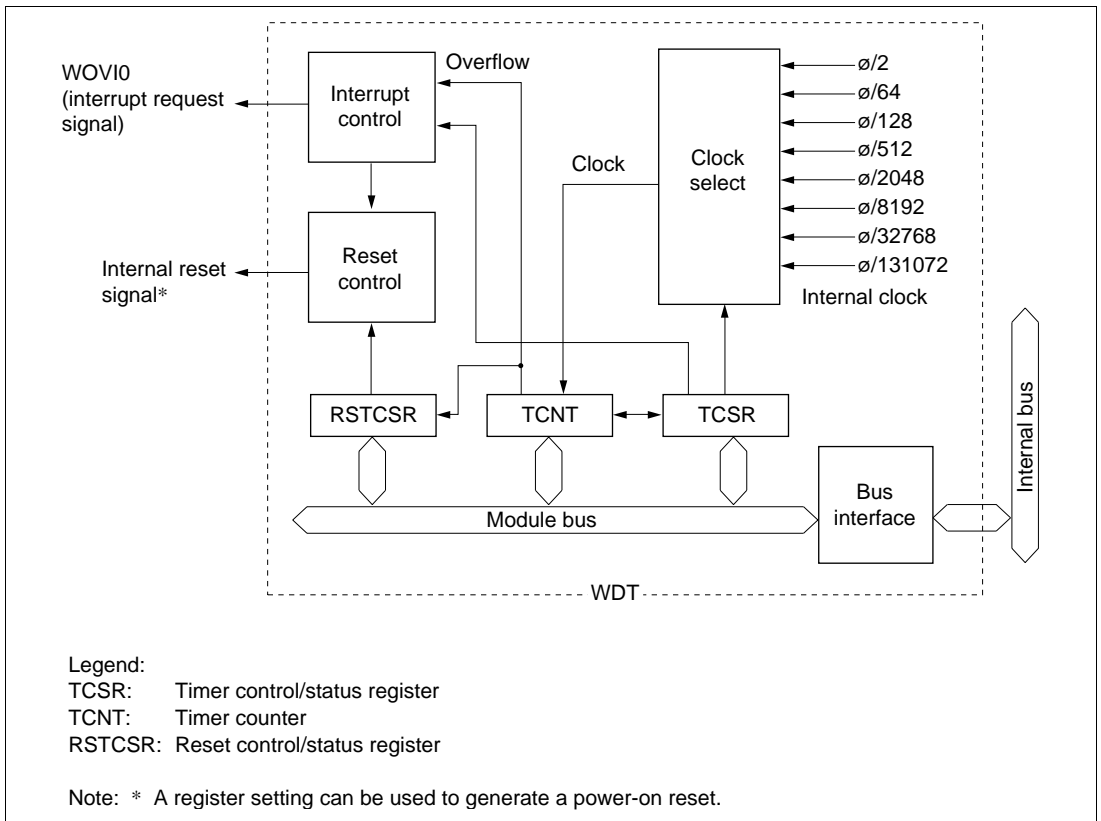
### 12.1.1 Features

WDT features are listed below.

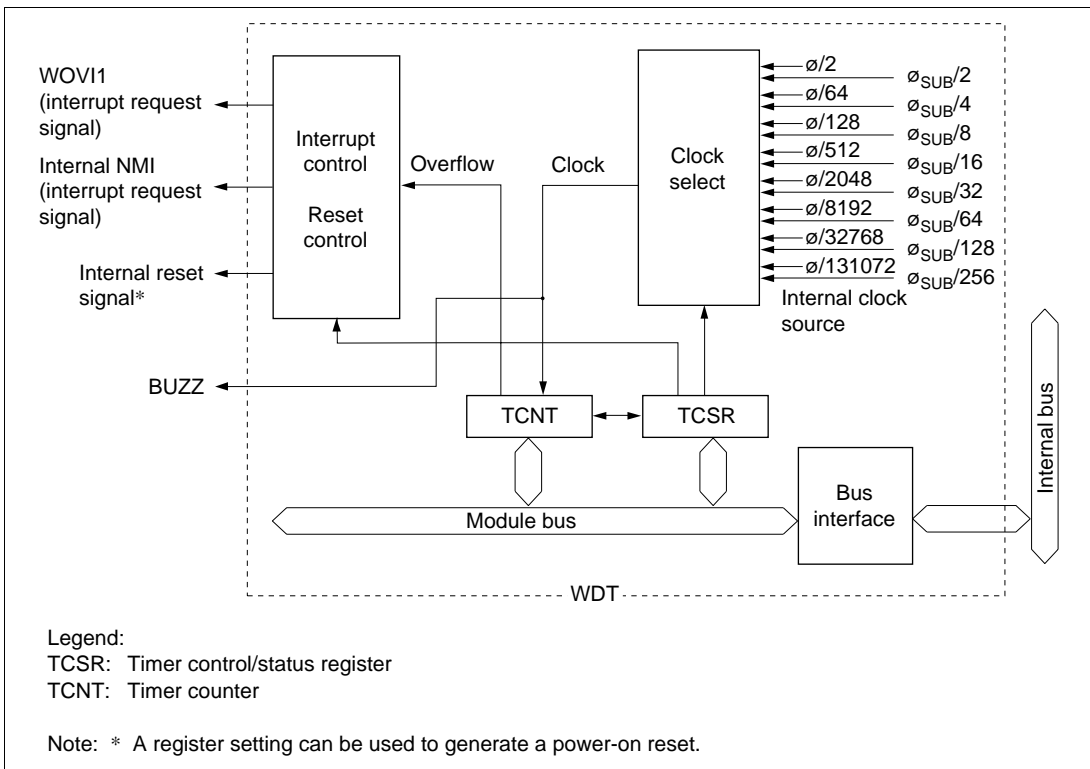
- Switchable between watchdog timer mode and interval timer mode
- Internal reset or internal interrupt generated when watchdog timer mode
  - WDT0
    - Choice of whether or not an internal power-on reset is effected when the counter overflows
  - WDT1
    - Choice of internal power-on reset or NMI interrupt generation when the counter overflows
- Interrupt generation in interval timer mode
  - An interval timer interrupt is generated when the counter overflows
- Choice of 8 (WDT0) or 16 (WDT1) counter input clocks
  - Maximum WDT interval: system clock period  $\times$  131072  $\times$  256
  - Subclock can be selected for the WDT1 input counter
    - Maximum interval when the subclock is selected: subclock period  $\times$  256  $\times$  256
- Selected clock can be output from the BUZZ output pin (WDT1)

## 12.1.2 Block Diagram

Figures 12.1 (a) and (b) show block diagrams of WDT0 and WDT1.



**Figure 12.1 (a) Block Diagram of WDT0**



**Figure 12.1 (b) Block Diagram of WDT1**

### 12.1.3 Pin Configuration

Table 12.1 describes the WDT pin.

**Table 12.1 WDT Pin**

Name	Symbol	I/O	Function
Buzzer output	BUZZ	Output	Outputs clock selected by watchdog timer (WDT1)

## 12.1.4 Register Configuration

Table 12.2 summarizes the WDT registers. These registers control clock selection, WDT mode switching, the reset signal, etc.

**Table 12.2 WDT Registers**

Channel	Name	Abbreviation	R/W	Initial Value	Address*1	
					Write*2	Read
0	Timer control/status register 0	TCSR0	R/(W)*3	H'18	H'FF74	H'FF74
	Timer counter 0	TCNT0	R/W	H'00	H'FF74	H'FF75
	Reset control/status register	RSTCSR	R/(W)*3	H'1F	H'FF76	H'FF77
1	Timer control/status register 1	TCSR1	R/(W)*3	H'00	H'FFA2	H'FFA2
	Timer counter 1	TCNT1	R/W	H'00	H'FFA2	H'FFA3
	Pin function control register	PFCR	R/W	H'0D/H'00*4	H'FDEB	H'FDEB

Notes: \*1 Lower 16 bits of the address.

\*2 For details of write operations, see section 12.2.5, Notes on Register Access.

\*3 Only 0 can be written in bit 7, to clear the flag.

\*4 Initialized to H'0D in modes 4 and 5, and to H'00 in modes 6 and 7.

## 12.2 Register Descriptions

### 12.2.1 Timer Counter (TCNT)

Bit	:	7	6	5	4	3	2	1	0
Initial value	:	0	0	0	0	0	0	0	0
R/W	:	R/W	R/W	R/W	R/W	R/W	R/W	R/W	R/W

TCNT is an 8-bit readable/writable\* up-counter.

When the TME bit is set to 1 in TCSR, TCNT starts counting pulses generated from the internal clock source selected by bits CKS2 to CKS0 in TCSR. When the count overflows (changes from H'FF to H'00), the OVF flag in TCSR is set to 1.

TCNT is initialized to H'00 by a reset, in hardware standby mode, or when the TME bit is cleared to 0. It is not initialized in software standby mode.

Note: \* TCNT is write-protected by a password to prevent accidental overwriting. For details see section 12.2.5, Notes on Register Access.

### 12.2.2 Timer Control/Status Register (TCSR)

- TCSR0

Bit	:	7	6	5	4	3	2	1	0
		OVF	WT/ $\bar{I}T$	TME	—	—	CKS2	CKS1	CKS0
Initial value	:	0	0	0	1	1	0	0	0
R/W	:	R/(W)*	R/W	R/W	—	—	R/W	R/W	R/W

Note: \* Only 0 can be written, to clear the flag.

- TCSR1

Bit	:	7	6	5	4	3	2	1	0
		OVF	WT/IT	TME	PSS	RST/NMI	CKS2	CKS1	CKS0
Initial value	:	0	0	0	0	0	0	0	0
R/W	:	R/(W)*	R/W	R/W	R/W	R/W	R/W	R/W	R/W

Note: \* Only 0 can be written, to clear the flag.

TCSR is an 8-bit readable/writable\* register. Its functions include selecting the clock source to be input to TCNT, and the timer mode.

TCR is initialized to H'18 (H'00) by a reset and in hardware standby mode. It is not initialized in software standby mode.

Note: \* TCSR is write-protected by a password to prevent accidental overwriting. For details see section 12.2.5, Notes on Register Access.

**Bit 7—Overflow Flag (OVF):** A status flag that indicates that TCNT has overflowed from H'FF to H'00.

#### Bit 7

OVF	Description
0	[Clearing conditions] (Initial value) <ul style="list-style-type: none"> <li>• Write 0 in the TME bit (Only applies to WDT1)</li> <li>• Read TCSR when OVF = 1, then write 0 in OVF*</li> </ul>
1	[Setting condition] <p>When TCNT overflows (changes from H'FF to H'00)</p> <p>When internal reset request generation is selected in watchdog timer mode, OVF is cleared automatically by the internal reset.</p>

Note: \* When the OVF flag is polled with the interval timer interrupt disabled, read the OVF bit while it is 1 at least twice.

**Bit 6—Timer Mode Select (WT/IT):** Selects whether the WDT is used as a watchdog timer or interval timer. If WDT0 is used in watchdog timer mode, it can generate a reset when TCNT overflows. If WDT0 is used in interval timer mode, it generates a WOV1 interrupt request to the CPU when TCNT overflows. WDT1 generates a power-on reset or NMI interrupt request if used in watchdog timer mode, and a WOV1 interrupt request if used in interval timer mode.

- WDT0 mode selection

#### WDT0 TCSR

WT/IT	Description
0	Interval timer mode: Interval timer interrupt (WOV1) request is sent to CPU when TCNT overflows (Initial value)
1	Watchdog timer mode: Internal reset can be selected when TCNT overflows*

Note: \* For details of the case where TCNT overflows in watchdog timer mode, see section 12.2.3, Reset Control/Status Register (RSTCSR).

- WDT1 mode selection

#### WDT1 TCSR

WT/IT	Description
0	Interval timer mode: Interval timer interrupt (WOV1) request is sent to CPU when TCNT overflows (Initial value)
1	Watchdog timer mode: Power-on reset or NMI interrupt request is sent to CPU when TCNT overflows

**Bit 5—Timer Enable (TME):** Selects whether TCNT runs or is halted.

#### Bit 5

TME	Description
0	TCNT is initialized to H'00 and count operation is halted (Initial value)
1	TCNT counts

**WDT0 TCSR Bit 4—Reserved:** This bit cannot be modified and is always read as 1.

**WDT1 TCSR Bit 4—Prescaler Select (PSS):** Selects the input clock source for TCNT in WDT1. For details, see the description of the CKS2 to CKS0 bits below.

#### WDT1 TCSR

##### Bit 4

PSS	Description
0	TCNT counts $\phi$ -based prescaler (PSM) divided clock pulses (Initial value)
1	TCNT counts $\phi$ SUB-based prescaler (PSS) divided clock pulses

**WDT0 TCSR Bit 3—Reserved:** This bit cannot be modified and is always read as 1.

**WDT1 TCSR Bit 3—Power-on Reset or NMI (RST/ $\overline{\text{NMI}}$ ):** Specifies whether a power-on reset or NMI interrupt is requested on TCNT overflow in watchdog timer mode.

##### Bit 3

RST/ $\overline{\text{NMI}}$	Description
0	An NMI interrupt is requested (Initial value)
1	A power-on reset is requested

**Bits 2 to 0—Clock Select 2 to 0 (CKS2 to CKS0):** These bits select an internal clock source, obtained by dividing the system clock ( $\phi$ ), or subclock ( $\phi$ SUB) for input to TCNT.

- WDT0 input clock selection

Bit 2	Bit 1	Bit 0	Description	
CKS2	CKS1	CKS0	Clock	Overflow Period* (when $\phi = 10 \text{ MHz}$ )
0	0	0	$\phi/2$ (Initial value)	51.2 $\mu\text{s}$
		1	$\phi/64$	1.6 ms
	1	0	$\phi/128$	3.2 ms
		1	$\phi/512$	13.2 ms
1	0	0	$\phi/2048$	52.4 ms
		1	$\phi/8192$	209.8 ms
	1	0	$\phi/32768$	838.8 ms
		1	$\phi/131072$	3.36 s

Note: \* The overflow period is the time from when TCNT starts counting up from H'00 until overflow occurs.



- WDT1 input clock selection

Bit 4	Bit 2	Bit 1	Bit 0	Description		
PSS	CKS2	CKS1	CKS0	Clock	Overflow Period	
0	0	0	0	$\emptyset/2$ (Initial value)	$51.2 \mu\text{s}^{*1}$	
			1	$\emptyset/64$	$1.6 \text{ ms}^{*1}$	
		1	0	$\emptyset/128$	$3.2 \text{ ms}^{*1}$	
			1	$\emptyset/512$	$13.2 \text{ ms}^{*1}$	
	1	0	0	$\emptyset/2048$	$52.4 \text{ ms}^{*1}$	
			1	$\emptyset/8192$	$209.8 \text{ ms}^{*1}$	
		1	0	$\emptyset/32768$	$838.8 \text{ ms}^{*1}$	
			1	$\emptyset/131072$	$3.36 \text{ s}^{*1}$	
1	0	0	0	$\emptyset\text{SUB}/2$	$6.7 \text{ ms}^{*2}$	$3.2 \text{ ms}^{*3}$
			1	$\emptyset\text{SUB}/4$	$13.3 \text{ ms}^{*2}$	$6.4 \text{ ms}^{*3}$
		1	0	$\emptyset\text{SUB}/8$	$26.7 \text{ ms}^{*2}$	$12.8 \text{ ms}^{*3}$
			1	$\emptyset\text{SUB}/16$	$53.3 \text{ ms}^{*2}$	$25.6 \text{ ms}^{*3}$
	1	0	0	$\emptyset\text{SUB}/32$	$106.7 \text{ ms}^{*2}$	$51.2 \text{ ms}^{*3}$
			1	$\emptyset\text{SUB}/64$	$213.3 \text{ ms}^{*2}$	$102.4 \text{ ms}^{*3}$
		1	0	$\emptyset\text{SUB}/128$	$426.7 \text{ ms}^{*2}$	$204.8 \text{ ms}^{*3}$
			1	$\emptyset\text{SUB}/256$	$853.3 \text{ ms}^{*2}$	$409.6 \text{ ms}^{*3}$

Notes: \*1 The time from TCNT starting to count up from H'00 until it overflows, when  $\emptyset = 10 \text{ MHz}$ .

\*2 The time from TCNT starting to count up from H'00 until it overflows, when  $\emptyset\text{SUB} = 76.8 \text{ kHz}$ .

\*3 The time from TCNT starting to count up from H'83 until it overflows, when  $\emptyset\text{SUB} = 160 \text{ kHz}$ .

### 12.2.3 Reset Control/Status Register (RSTCSR) (WDT0 Only)

Bit	:	7	6	5	4	3	2	1	0
		WOVF	RSTE	—	—	—	—	—	—
Initial value	:	0	0	0	1	1	1	1	1
R/W	:	R/(W) *	R/W	R/W	—	—	—	—	—

Note: \* Only 0 can be written, to clear the flag.

RSTCSR is an 8-bit readable/writable\* register that controls the generation of the internal reset signal when TCNT overflows, and selects the type of internal reset signal.

RSTCSR is initialized to H'1F by a reset signal from the  $\overline{\text{RES}}$  pin, but not by the internal reset signal caused by a WDT overflow.

Note: \* RSTCSR is write-protected by a password to prevent accidental overwriting. For details see section 12.2.5, Notes on Register Access.

**Bit 7—Watchdog Overflow Flag (WOVF):** Indicates that TCNT has overflowed (from H'FF to H'00) during watchdog timer operation. This bit is not set in interval timer mode.

#### Bit 7

WOVF	Description
0	[Clearing condition] (Initial value) Cleared by reading RSTCSR when WOVF = 1, then writing 0 to WOVF
1	[Setting condition] When TCNT overflows (from H'FF to H'00) in watchdog timer mode

**Bit 6—Reset Enable (RSTE):** Specifies whether or not an internal reset signal is generated if TCNT overflows in watchdog timer mode.

#### Bit 6

RSTE	Description
0	No internal reset when TCNT overflows* (Initial value)
1	Internal reset is generated when TCNT overflows

Note: \* The chip is not reset internally, but TCNT and TCSR in WDT0 are reset.

**Bit 5—Reserved:** Only 0 may be written to this bit.

**Bits 4 to 0—Reserved:** These bits cannot be modified and are always read as 1.

#### 12.2.4 Pin Function Control Register (PFCR)

Bit	:	7	6	5	4	3	2	1	0
		—	—	BUZZE	—	AE3	AE2	AE1	AE0
Modes 4 and 5									
Initial value	:	0	0	0	0	1	1	0	1
Modes 6 and 7									
Initial value	:	0	0	0	0	0	0	0	0
R/W	:	R/W	R/W	R/W	R/W	R/W	R/W	R/W	R/W

PFCR is an 8-bit readable/writable register that performs address output control in external expanded mode.

Only bit 5 is described here. For details of the other bits, see section 7.2.6, Pin Function Control Register (PFCR).

**Bit 5—BUZZ Output Enable (BUZZE):** Enables or disables BUZZ output from the PF1 pin. The WDT1 input clock selected with bits PSS and CKS2 to CKS0 is output as the BUZZ signal.

##### Bit 5

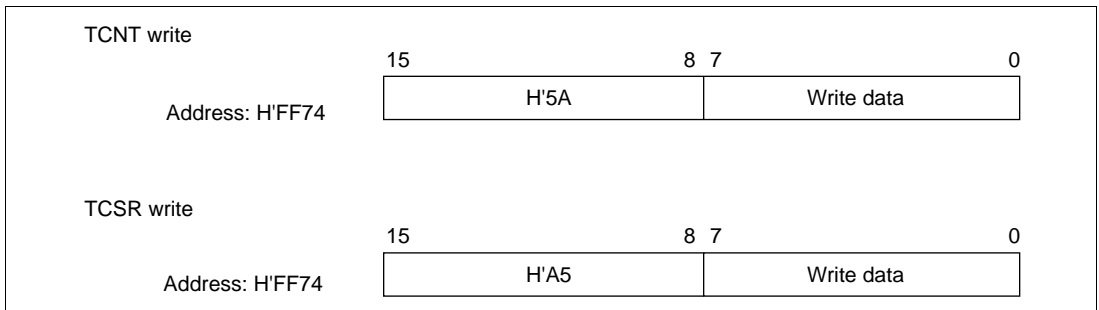
<b>BUZZE</b>	<b>Description</b>
0	Functions as PF1 I/O pin (Initial value)
1	Functions as BUZZ output pin

## 12.2.5 Notes on Register Access

The watchdog timer's TCNT, TCSR, and RSTCSR registers differ from other registers in being more difficult to write to. The procedures for writing to and reading these registers are given below.

**Writing to TCNT and TCSR:** These registers must be written to by a word transfer instruction. They cannot be written to with byte transfer instructions.

Figure 12.2 shows the format of data written to TCNT and TCSR. TCNT and TCSR both have the same write address. For a write to TCNT, the upper byte of the written word must contain H'5A and the lower byte must contain the write data. For a write to TCSR, the upper byte of the written word must contain H'A5 and the lower byte must contain the write data. This transfers the write data from the lower byte to TCNT or TCSR.

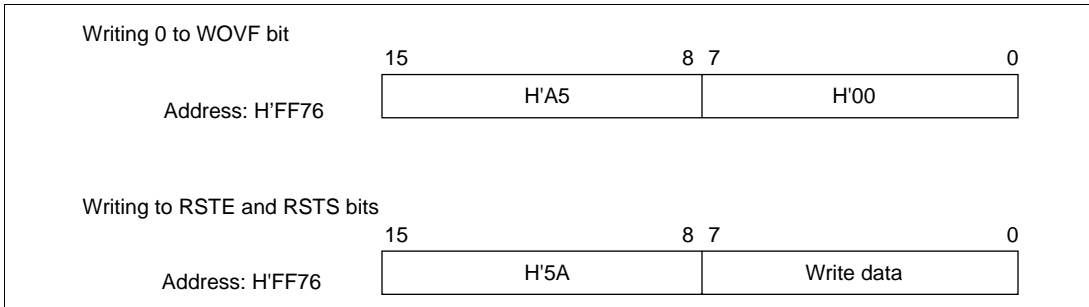


**Figure 12.2 Format of Data Written to TCNT and TCSR (Example of WDT0)**

**Writing to RSTCSR:** RSTCSR must be written to by a word transfer to address H'FF76. It cannot be written to with byte instructions.

Figure 12.3 shows the format of data written to RSTCSR. The method of writing 0 to the WOVF bit differs from that for writing to the RSTE and RSTS bits.

To write 0 to the WOVF bit, the upper byte of the written word must contain H'A5 and the lower byte must contain H'00. This clears the WOVF bit to 0, but has no effect on the RSTE and RSTS bits. To write to the RSTE and RSTS bits, the upper byte must contain H'5A and the lower byte must contain the write data. This writes the values in bits 6 and 5 of the lower byte into the RSTE and RSTS bits, but has no effect on the WOVF bit.



**Figure 12.3 Format of Data Written to RSTCSR (Example of WDT0)**

**Reading TCNT, TCSR, and RSTCSR (Example of WDT0):** These registers are read in the same way as other registers. The read addresses are H'FF74 for TCSR, H'FF75 for TCNT, and H'FF77 for RSTCSR.

## 12.3 Operation

### 12.3.1 Watchdog Timer Operation

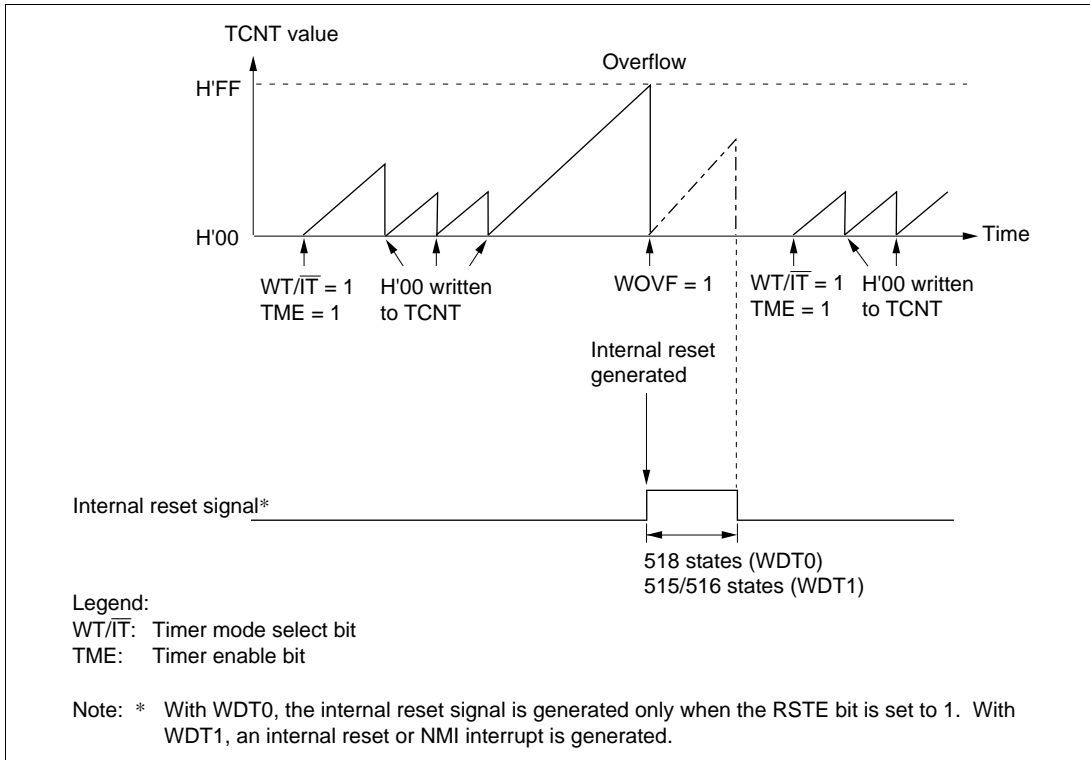
To use the WDT as a watchdog timer, set the  $\overline{WT/IT}$  and TME bits in TCSR to 1. Software must prevent TCNT overflows by rewriting the TCNT value (normally by writing H'00) before overflow occurs.

In this way, TCNT will not overflow while the system is operating normally, but if TCNT is not rewritten and overflows because of a system crash or other error, in the case of WDT0, if the RSTE bit in RSTCSR is set to 1 beforehand, a signal is generated that effects an internal chip reset. The internal reset signal is output for 518 states. This is illustrated in figure 12.4.

If a reset caused by an input signal from the  $\overline{RES}$  pin and a reset caused by WDT overflow occur simultaneously, the  $\overline{RES}$  pin reset has priority, and the WOVF bit in RSTCSR is cleared to 0.

In the case of WDT1, the chip is reset, or an NMI interrupt request is generated, for 516 system clock periods ( $516\phi$ ) (515 or 516 clock periods when the clock source is  $\phi_{sub}$  ( $PSS = 1$ )). This is illustrated in figure 12.4.

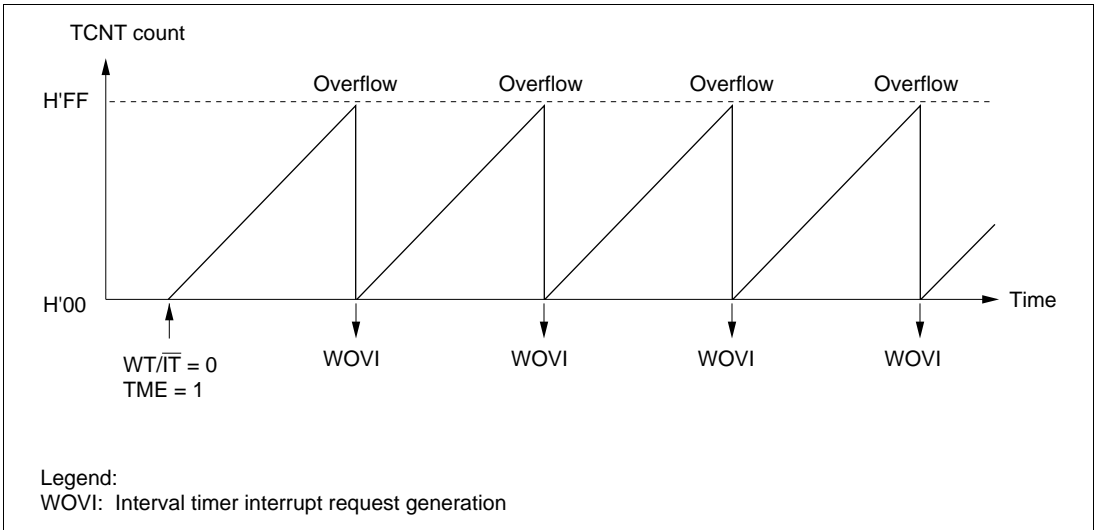
An NMI interrupt request from the watchdog timer and an interrupt request from the NMI pin are handled via the same vector. Simultaneous handling of a watchdog timer NMI interrupt request and an NMI pin interrupt request must therefore be avoided.



**Figure 12.4 Operation in Watchdog Timer Mode**

### 12.3.2 Interval Timer Operation

To use the WDT as an interval timer, clear the  $WT/\overline{IT}$  bit in TCSR to 0 and set the TME bit to 1. An interval timer interrupt (WOVI) is generated each time TCNT overflows, provided that the WDT is operating as an interval timer, as shown in figure 12.5. This function can be used to generate interrupt requests at regular intervals.

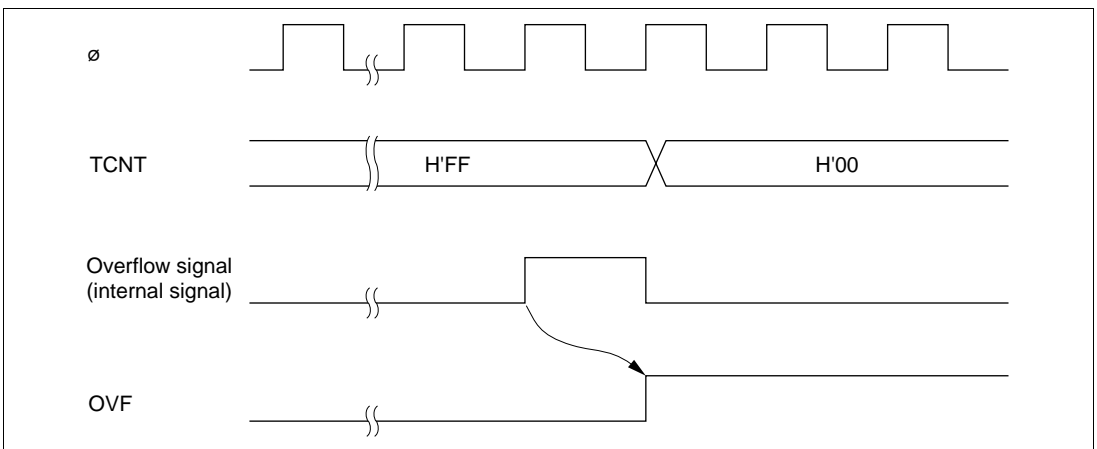


**Figure 12.5 Operation in Interval Timer Mode**

### 12.3.3 Timing of Setting of Overflow Flag (OVF)

The OVF flag is set to 1 if TCNT overflows during interval timer operation. At the same time, an interval timer interrupt (WOVI) is requested. This timing is shown in figure 12.6.

If NMI request generation is selected in watchdog timer mode, when TCNT overflows the OVF bit in TCSR is set to 1 and at the same time an NMI interrupt is requested.



**Figure 12.6 Timing of OVF Setting**

### 12.3.4 Timing of Setting of Watchdog Timer Overflow Flag (WOVF)

With WDT0, the WOVF bit in RSTCSR is set to 1 if TCNT overflows in watchdog timer mode. If TCNT overflows while the RSTE bit in RSTCSR is set to 1, an internal reset signal is generated for the entire chip. This timing is illustrated in figure 12.7.

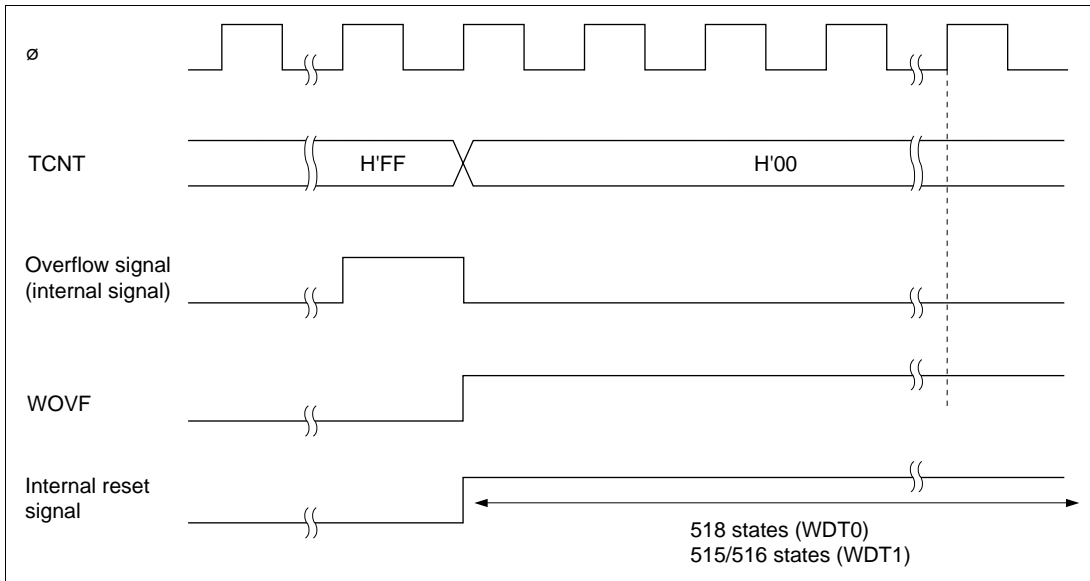


Figure 12.7 Timing of WOVF Setting

## 12.4 Interrupts

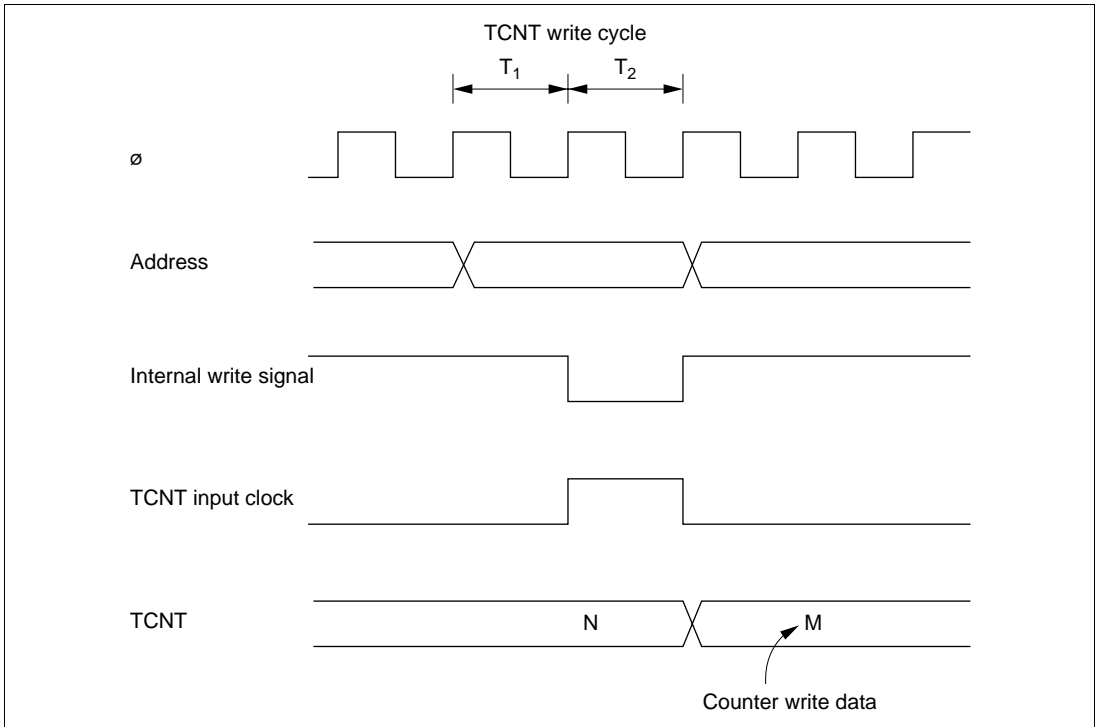
During interval timer mode operation, an overflow generates an interval timer interrupt (WOVI). The interval timer interrupt is requested whenever the OVF flag is set to 1 in TCSR. OVF must be cleared to 0 in the interrupt handling routine. When NMI interrupt request generation is selected in watchdog timer mode, an overflow generates an NMI interrupt request.



## 12.5 Usage Notes

### 12.5.1 Contention between Timer Counter (TCNT) Write and Increment

If a timer counter clock pulse is generated during the T2 state of a TCNT write cycle, the write takes priority and the timer counter is not incremented. Figure 12.8 shows this operation.



**Figure 12.8 Contention between TCNT Write and Increment**

### 12.5.2 Changing Value of PSS and CKS2 to CKS0

If bits PSS and CKS2 to CKS0 in TCSR are written to while the WDT is operating, errors could occur in the incrementation. Software must stop the watchdog timer (by clearing the TME bit to 0) before changing the value of bits PSS and CKS2 to CKS0.

### 12.5.3 Switching between Watchdog Timer Mode and Interval Timer Mode

If the mode is switched from watchdog timer to interval timer, or vice versa, while the WDT is operating, errors could occur in the incrementation. Software must stop the watchdog timer (by clearing the TME bit to 0) before switching the mode.

#### 12.5.4 Internal Reset in Watchdog Timer Mode

If the RSTE bit is cleared to 0 in watchdog timer mode, the chip will not be reset internally if TCNT overflows, but TCNT0 and TCSR0 in WDT0 will be reset.

TCNT, TCSR, and RSTCR cannot be written to for a 132-state interval after overflow occurs, and a read of the WOVF flag is not recognized during this time. It is therefore necessary to wait for 132 states after overflow occurs before writing 0 to the WOVF flag to clear it.

# Section 13 Serial Communication Interface (SCI)

## 13.1 Overview

The LSI is equipped with a mutually independent 3-channel\* serial communication interface (SCI). The SCI can handle both asynchronous and clocked synchronous serial communication. A function is also provided for serial communication between processors (multiprocessor communication function).

Note: \* SCI3 is dedicated for use with the FLEX™ decoder II interface, and so does not appear on an external pin.

### 13.1.1 Features

SCI features are listed below.

- Choice of asynchronous or clocked synchronous serial communication mode

#### Asynchronous mode

— Serial data communication executed using asynchronous system in which synchronization is achieved character by character

Serial data communication can be carried out with standard asynchronous communication chips such as a Universal Asynchronous Receiver/Transmitter (UART) or Asynchronous Communication Interface Adapter (ACIA)

— A multiprocessor communication function is provided that enables serial data communication with a number of processors

— Choice of 12 serial data transfer formats

Data length : 7 or 8 bits

Stop bit length : 1 or 2 bits

Parity : Even, odd, or none

Multiprocessor bit : 1 or 0

— Receive error detection : Parity, overrun, and framing errors

— Break detection : Break can be detected by reading the RxD pin level directly in case of a framing error

#### Clocked Synchronous mode

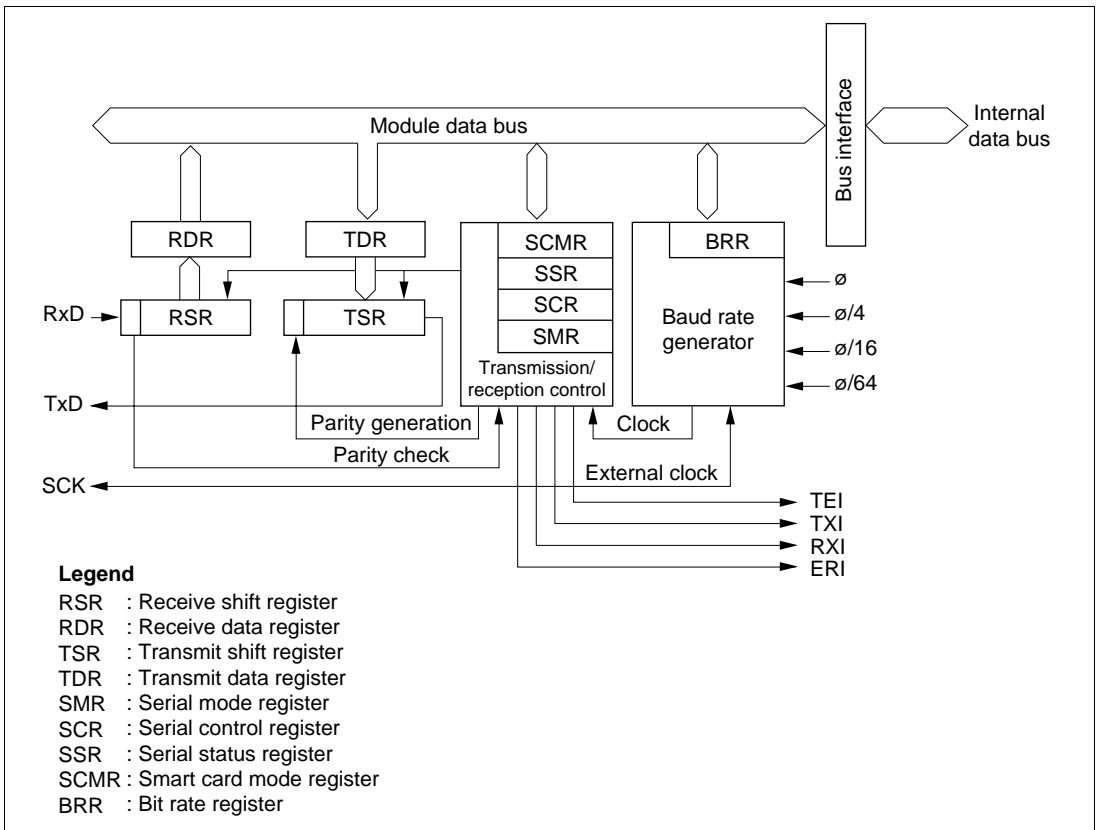
— Serial data communication synchronized with a clock

Serial data communication can be carried out with other chips that have a synchronous communication function

- One serial data transfer format
  - Data length : 8 bits
- Receive error detection : Overrun errors detected
- Full-duplex communication capability
  - The transmitter and receiver are mutually independent, enabling transmission and reception to be executed simultaneously
  - Double-buffering is used in both the transmitter and the receiver, enabling continuous transmission and continuous reception of serial data
- Choice of LSB-first or MSB-first transfer
  - Can be selected regardless of the communication mode\* (except in the case of asynchronous mode 7-bit data)
  - Note: \* Descriptions in this section refer to LSB-first transfer.
- On-chip baud rate generator allows any bit rate to be selected
- Choice of serial clock source: internal clock from baud rate generator or external clock from SCK pin (Except SCI3. Serial clock source of SCI3 is only internal clock)
- Four interrupt sources
  - Four interrupt sources — transmit-data-empty, transmit-end, receive-data-full, and receive error — that can issue requests independently
  - The transmit-data-empty interrupt and receive data full interrupts can activate the data transfer controller (DTC) to execute data transfer
- Module stop mode can be set
  - As the initial setting, SCI operation is halted. Register access is enabled by exiting module stop mode.

## 13.1.2 Block Diagram

Figure 13.1 shows a block diagram of the SCI.



**Figure 13.1 Block Diagram of SCI**

### 13.1.3 Pin Configuration

Table 13.1 shows the serial pins for each SCI channel.

**Table 13.1 SCI Pins**

Channel	Pin Name	Symbol	I/O	Function
0	Serial clock pin 0	SCK0	I/O	SCI0 clock input/output
	Receive data pin 0	RxD0	Input	SCI0 receive data input
	Transmit data pin 0	TxD0	Output	SCI0 transmit data output
1	Serial clock pin 1	SCK1	I/O	SCI1 clock input/output
	Receive data pin 1	RxD1	Input	SCI1 receive data input
	Transmit data pin 1	TxD1	Output	SCI1 transmit data output
3 (dedicated to the FLEX™ decoder II interface)	Serial clock pin 3*	SCK3	Output	SCI3 clock output
	Receive data pin 3*	RxD3	Input	SCI3 receive data input
	Transmit data pin 3*	TxD3	Output	SCI3 transmit data output

Notes: Pin names SCK, RxD, and TxD are used in the text for all channels, omitting the channel designation.

- \* Dedicated for the FLEX™ decoder II interface, and does not have LSI-external connection point.

### 13.1.4 Register Configuration

The SCI has the internal registers shown in table 13.2. These registers are used to specify asynchronous mode or clocked synchronous mode, the data format, and the bit rate, and to control transmitter/receiver.

**Table 13.2 SCI Registers**

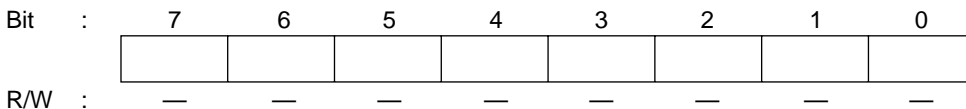
Channel	Name	Abbreviation	R/W	Initial Value	Address* <sup>1</sup>
0	Serial mode register 0	SMR0	R/W	H'00	H'FF78
	Bit rate register 0	BRR0	R/W	H'FF	H'FF79
	Serial control register 0	SCR0	R/W	H'00	H'FF7A
	Transmit data register 0	TDR0	R/W	H'FF	H'FF7B
	Serial status register 0	SSR0	R/(W)* <sup>2</sup>	H'84	H'FF7C
	Receive data register 0	RDR0	R	H'00	H'FF7D
	Smart card mode register 0	SCMR0	R/W	H'F2	H'FF7E
1	Serial mode register 1	SMR1	R/W	H'00	H'FF80
	Bit rate register 1	BRR1	R/W	H'FF	H'FF81
	Serial control register 1	SCR1	R/W	H'00	H'FF82
	Transmit data register 1	TDR1	R/W	H'FF	H'FF83
	Serial status register 1	SSR1	R/(W)* <sup>2</sup>	H'84	H'FF84
	Receive data register 1	RDR1	R	H'00	H'FF85
	Smart card mode register 1	SCMR1	R/W	H'F2	H'FF86
3 (dedicated to the FLEX™ decoder II interface)	Serial mode register 3	SMR3	R/W	H'00	H'FDD0
	Bit rate register 3	BRR3	R/W	H'FF	H'FDD1
	Serial control register 3	SCR3	R/W	H'00	H'FDD2
	Transmit data register 3	TDR3	R/W	H'FF	H'FDD3
	Serial status register 3	SSR3	R/(W)* <sup>2</sup>	H'84	H'FDD4
	Receive data register 3	RDR3	R	H'00	H'FDD5
	Smart card mode register 3	SCMR3	R/W	H'F2	H'FDD6
Common	Module stop control register B	MSTPCRB	R/W	H'FF	H'FDE9
	Module stop control register C	MSTPCRC	R/W	H'FF	H'FDEA

Notes: \*1 Lower 16 bits of the address.

\*2 Can only be written with 0 for flag clearing.

## 13.2 Register Descriptions

### 13.2.1 Receive Shift Register (RSR)

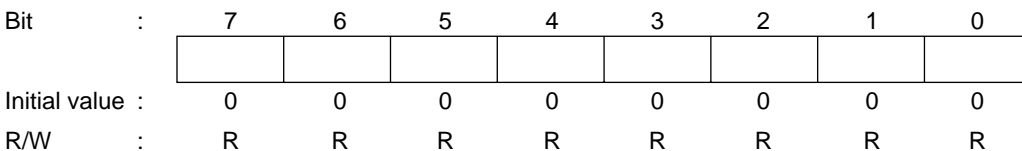


RSR is a register used to receive serial data.

The SCI sets serial data input from the RxD pin in RSR in the order received, starting with the LSB (bit 0), and converts it to parallel data. When one byte of data has been received, it is transferred to RDR automatically.

RSR cannot be directly read or written to by the CPU.

### 13.2.2 Receive Data Register (RDR)



RDR is a register that stores received serial data.

When the SCI has received one byte of serial data, it transfers the received serial data from RSR to RDR where it is stored, and completes the receive operation. After this, RSR is receive-enabled.

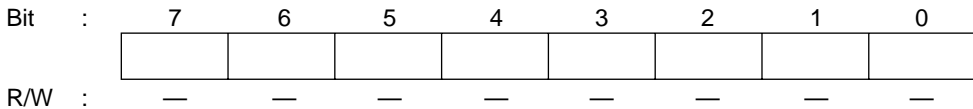
Since RSR and RDR function as a double buffer in this way, enables continuous receive operations to be performed.

RDR is a read-only register, and cannot be written to by the CPU.

RDR is initialized to H'00 by a reset, in standby mode, watch mode, subactive mode, and subsleep mode or module stop mode.



### 13.2.3 Transmit Shift Register (TSR)



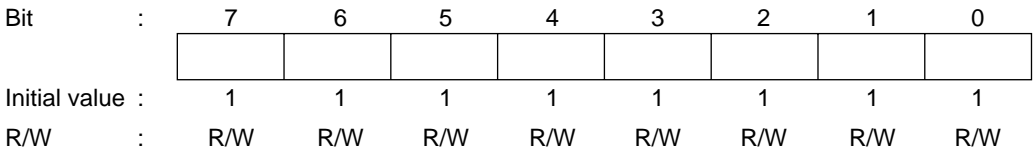
TSR is a register used to transmit serial data.

To perform serial data transmission, the SCI first transfers transmit data from TDR to TSR, then sends the data to the TxD pin starting with the LSB (bit 0).

When transmission of one byte is completed, the next transmit data is transferred from TDR to TSR, and transmission started, automatically. However, data transfer from TDR to TSR is not performed if the TDRE bit in SSR is set to 1.

TSR cannot be directly read or written to by the CPU.

### 13.2.4 Transmit Data Register (TDR)



TDR is an 8-bit register that stores data for serial transmission.

When the SCI detects that TSR is empty, it transfers the transmit data written in TDR to TSR and starts serial transmission. Continuous serial transmission can be carried out by writing the next transmit data to TDR during serial transmission of the data in TSR.

TDR can be read or written to by the CPU at all times.

TDR is initialized to H'FF by a reset, in standby mode, watch mode, subactive mode, and subsleep mode or module stop mode.

### 13.2.5 Serial Mode Register (SMR)

Bit	:	7	6	5	4	3	2	1	0
		C/ $\bar{A}$	CHR	PE	O/ $\bar{E}$	STOP	MP	CKS1	CKS0
Initial value	:	0	0	0	0	0	0	0	0
R/W	:	R/W	R/W	R/W	R/W	R/W	R/W	R/W	R/W

SMR is an 8-bit register used to set the SCI's serial transfer format and select the baud rate generator clock source.

SMR can be read or written to by the CPU at all times.

SMR is initialized to H'00 by a reset and in hardware standby mode. It retains its previous state in module stop mode, software standby mode, watch mode, subactive mode, and subsleep mode.

**Bit 7—Communication Mode (C/ $\bar{A}$ ):** Selects asynchronous mode or clocked synchronous mode as the SCI operating mode.

#### Bit 7

C/ $\bar{A}$	Description
0	Asynchronous mode (Initial value)
1	Clocked synchronous mode

**Bit 6—Character Length (CHR):** Selects 7 or 8 bits as the data length in asynchronous mode. In clocked synchronous mode, a fixed data length of 8 bits is used regardless of the CHR setting.

#### Bit 6

CHR	Description
0	8-bit data (Initial value)
1	7-bit data*

Note: \* When 7-bit data is selected, the MSB (bit 7) of TDR is not transmitted, and it is not possible to choose between LSB-first or MSB-first transfer.

**Bit 5—Parity Enable (PE):** In asynchronous mode, selects whether or not parity bit addition is performed in transmission, and parity bit checking in reception. In clocked synchronous mode with a multiprocessor format, parity bit addition and checking is not performed, regardless of the PE bit setting.

#### Bit 5

PE	Description
0	Parity bit addition and checking disabled (Initial value)
1	Parity bit addition and checking enabled*

Note: \*When the PE bit is set to 1, the parity (even or odd) specified by the  $O/\bar{E}$  bit is added to transmit data before transmission. In reception, the parity bit is checked for the parity (even or odd) specified by the  $O/\bar{E}$  bit.

**Bit 4—Parity Mode ( $O/\bar{E}$ ):** Selects either even or odd parity for use in parity addition and checking.

The  $O/\bar{E}$  bit setting is only valid when the PE bit is set to 1, enabling parity bit addition and checking, in asynchronous mode. The  $O/\bar{E}$  bit setting is invalid in clocked synchronous mode, when parity addition and checking is disabled in asynchronous mode, and when a multiprocessor format is used.

#### Bit 4

$O/\bar{E}$	Description
0	Even parity* <sup>1</sup> (Initial value)
1	Odd parity* <sup>2</sup>

Notes: \*1 When even parity is set, parity bit addition is performed in transmission so that the total number of 1 bits in the transmit character plus the parity bit is even.

In reception, a check is performed to see if the total number of 1 bits in the receive character plus the parity bit is even.

\*2 When odd parity is set, parity bit addition is performed in transmission so that the total number of 1 bits in the transmit character plus the parity bit is odd.

In reception, a check is performed to see if the total number of 1 bits in the receive character plus the parity bit is odd.

**Bit 3—Stop Bit Length (STOP):** Selects 1 or 2 bits as the stop bit length in asynchronous mode. The STOP bits setting is only valid in asynchronous mode. If clocked synchronous mode is set the STOP bit setting is invalid since stop bits are not added.

**Bit 3**

STOP	Description
0	1 stop bit: In transmission, a single 1 bit (stop bit) is added to the end of a transmit character before it is sent. (Initial value)
1	2 stop bits: In transmission, two 1 bits (stop bits) are added to the end of a transmit character before it is sent.

In reception, only the first stop bit is checked, regardless of the STOP bit setting. If the second stop bit is 1, it is treated as a stop bit; if it is 0, it is treated as the start bit of the next transmit character.

**Bit 2—Multiprocessor Mode (MP):** Selects multiprocessor format. When multiprocessor format is selected, the PE bit and O $\bar{E}$  bit parity settings are invalid. The MP bit setting is only valid in asynchronous mode; it is invalid in clocked synchronous mode.

For details of the multiprocessor communication function, see section 13.3.3, Multiprocessor Communication Function.

**Bit 2**

MP	Description
0	Multiprocessor function disabled (Initial value)
1	Multiprocessor format selected

**Bits 1 and 0—Clock Select 1 and 0 (CKS1, CKS0):** These bits select the clock source for the baud rate generator. The clock source can be selected from  $\emptyset$ ,  $\emptyset/4$ ,  $\emptyset/16$ , and  $\emptyset/64$ , according to the setting of bits CKS1 and CKS0.

For the relation between the clock source, the bit rate register setting, and the baud rate, see section 13.2.8, Bit Rate Register.

Bit 1	Bit 0	Description
CKS1	CKS0	
0	0	$\emptyset$ clock (Initial value)
	1	$\emptyset/4$ clock
1	0	$\emptyset/16$ clock
	1	$\emptyset/64$ clock

### 13.2.6 Serial Control Register (SCR)

Bit	:	7	6	5	4	3	2	1	0
		TIE	RIE	TE	RE	MPIE	TEIE	CKE1	CKE0
Initial value	:	0	0	0	0	0	0	0	0
R/W	:	R/W	R/W	R/W	R/W	R/W	R/W	R/W	R/W

SCR is a register that performs enabling or disabling of SCI transfer operations, serial clock output in asynchronous mode, and interrupt requests, and selection of the serial clock source.

SCR can be read or written to by the CPU at all times.

SCR is initialized to H'00 by a reset and in hardware standby mode. It retains its previous state in module stop mode, software standby mode, watch mode, subactive mode, and subsleep mode.

**Bit 7—Transmit Interrupt Enable (TIE):** Enables or disables transmit data empty interrupt (TXI) request generation when serial transmit data is transferred from TDR to TSR and the TDRE flag in SSR is set to 1.

#### Bit 7

TIE	Description
0	Transmit data empty interrupt (TXI) requests disabled (Initial value)
1	Transmit data empty interrupt (TXI) requests enabled

Note: TXI interrupt request cancellation can be performed by reading 1 from the TDRE flag, then clearing it to 0, or clearing the TIE bit to 0.

**Bit 6—Receive Interrupt Enable (RIE):** Enables or disables receive data full interrupt (RXI) request and receive error interrupt (ERI) request generation when serial receive data is transferred from RSR to RDR and the RDRF flag in SSR is set to 1.

#### Bit 6

RIE	Description
0	Receive data full interrupt (RXI) request and receive error interrupt (ERI) request disabled* (Initial value)
1	Receive data full interrupt (RXI) request and receive error interrupt (ERI) request enabled

Note: \*RXI and ERI interrupt request cancellation can be performed by reading 1 from the RDRF flag, or the FER, PER, or ORER flag, then clearing the flag to 0, or clearing the RIE bit to 0.

**Bit 5—Transmit Enable (TE):** Enables or disables the start of serial transmission by the SCI.

#### Bit 5

TE	Description
0	Transmission disabled* <sup>1</sup> (Initial value)
1	Transmission enabled* <sup>2</sup>

Notes: \*1 The TDRE flag in SSR is fixed at 1.

\*2 In this state, serial transmission is started when transmit data is written to TDR and the TDRE flag in SSR is cleared to 0.

SMR setting must be performed to decide the transfer format before setting the TE bit to 1.

**Bit 4—Receive Enable (RE):** Enables or disables the start of serial reception by the SCI.

#### Bit 4

RE	Description
0	Reception disabled* <sup>1</sup> (Initial value)
1	Reception enabled* <sup>2</sup>

Notes: \*1 Clearing the RE bit to 0 does not affect the RDRF, FER, PER, and ORER flags, which retain their states.

\*2 Serial reception is started in this state when a start bit is detected in asynchronous mode or serial clock input is detected in clocked synchronous mode.

SMR setting must be performed to decide the transfer format before setting the RE bit to 1.

**Bit 3—Multiprocessor Interrupt Enable (MPIE):** Enables or disables multiprocessor interrupts. The MPIE bit setting is only valid in asynchronous mode when the MP bit in SMR is set to 1.

The MPIE bit setting is invalid in clocked synchronous mode or when the MP bit is cleared to 0.

#### Bit 3

MPIE	Description
0	Multiprocessor interrupts disabled (normal reception performed) (Initial value) [Clearing conditions] <ul style="list-style-type: none"><li>• When the MPIE bit is cleared to 0</li><li>• When MPB= 1 data is received</li></ul>
1	Multiprocessor interrupts enabled* Receive interrupt (RXI) requests, receive error interrupt (ERI) requests, and setting of the RDRF, FER, and ORER flags in SSR are disabled until data with the multiprocessor bit set to 1 is received.

Note: \* When receive data including MPB = 0 is received, receive data transfer from RSR to RDR, receive error detection, and setting of the RDRF, FER, and ORER flags in SSR, is not

performed. When receive data including MPB = 1 is received, the MPB bit in SSR is set to 1, the MPIE bit is cleared to 0 automatically, and generation of RXI and ERI interrupts (when the TIE and RIE bits in SCR are set to 1) and FER and ORER flag setting is enabled.

**Bit 2—Transmit End Interrupt Enable (TEIE):** Enables or disables transmit end interrupt (TEI) request generation when there is no valid transmit data in TDR in MSB data transmission.

**Bit 2**

TEIE	Description
0	Transmit end interrupt (TEI) request disabled* (Initial value)
1	Transmit end interrupt (TEI) request enabled*

Note: \*TEI cancellation can be performed by reading 1 from the TDRE flag in SSR, then clearing it to 0 and clearing the TEND flag to 0, or clearing the TEIE bit to 0.

**Bits 1 and 0—Clock Enable 1 and 0 (CKE1, CKE0):** These bits are used to select the SCI clock source and enable or disable clock output from the SCK pin. The combination of the CKE1 and CKE0 bits determines whether the SCK pin functions as an I/O port, the serial clock output pin, or the serial clock input pin.

The setting of the CKE0 bit, however, is only valid for internal clock operation (CKE1 = 0) in asynchronous mode. The CKE0 bit setting is invalid in clocked synchronous mode, and in the case of external clock operation (CKE1 = 1). Note that the SCI's operating mode must be decided using SMR after setting the CKE1 and CKE0 bits.

External clock operation (CKE1 = 1) is disabled for the SCI3 that is the internal FLEX™ decoder II interface. The CKE1 bit should always be written with 0.

For details of clock source selection, see table 13.9 in section 13.3, Operation.

Bit 1	Bit 0	Description	
CKE1	CKE0	Description	
0	0	Asynchronous mode	Internal clock/SCK pin functions as I/O port* <sup>1</sup>
		Clocked synchronous mode	Internal clock/SCK pin functions as serial clock output* <sup>1</sup>
	1	Asynchronous mode	Internal clock/SCK pin functions as clock output* <sup>2</sup>
		Clocked synchronous mode	Internal clock/SCK pin functions as serial clock output
1* <sup>4</sup>	0	Asynchronous mode	External clock/SCK pin functions as clock input* <sup>3</sup>
		Clocked synchronous mode	External clock/SCK pin functions as serial clock input
	1	Asynchronous mode	External clock/SCK pin functions as clock input* <sup>3</sup>
		Clocked synchronous mode	External clock/SCK pin functions as serial clock input

Notes: \*1 Initial value

\*2 Outputs a clock of the same frequency as the bit rate.

\*3 Inputs a clock with a frequency 16 times the bit rate.

\*4 The CKE1 bit of SCR (channel 3) should always be written with 0.

### 13.2.7 Serial Status Register (SSR)

Bit	:	7	6	5	4	3	2	1	0
		TDRE	RDRF	ORER	FER	PER	TEND	MPB	MPBT
Initial value	:	1	0	0	0	0	1	0	0
R/W	:	R/(W)*	R/(W)*	R/(W)*	R/(W)*	R/(W)*	R	R	R/W

Note: \* Only 0 can be written, to clear the flag.

SSR is an 8-bit register containing status flags that indicate the operating status of the SCI, and multiprocessor bits.

SSR can be read or written to by the CPU at all times. However, 1 cannot be written to flags TDRE, RDRF, ORER, PER, and FER. Also note that in order to clear these flags they must be read as 1 beforehand. The TEND flag and MPB flag are read-only flags and cannot be modified.

SSR is initialized to H'84 by a reset, in standby mode, watch mode, subactive mode, and subsleep mode or module stop mode.



**Bit 7—Transmit Data Register Empty (TDRE):** Indicates that data has been transferred from TDR to TSR and the next serial data can be written to TDR.

#### Bit 7

TDRE	Description
0	[Clearing conditions] <ul style="list-style-type: none"> <li>When 0 is written to TDRE after reading TDRE = 1</li> <li>When the DTC is activated by a TXI interrupt and writes data to TDR</li> </ul>
1	[Setting conditions] (Initial value) <ul style="list-style-type: none"> <li>When the TE bit in SCR is 0</li> <li>When data is transferred from TDR to TSR and data can be written to TDR</li> </ul>

**Bit 6—Receive Data Register Full (RDRF):** Indicates that the received data is stored in RDR.

#### Bit 6

RDRF	Description
0	[Clearing conditions] (Initial value) <ul style="list-style-type: none"> <li>When 0 is written to RDRF after reading RDRF = 1</li> <li>When the DTC is activated by an RXI interrupt and reads data from RDR</li> </ul>
1	[Setting condition] <p>When serial reception ends normally and receive data is transferred from RSR to RDR</p>

Note: RDR and the RDRF flag are not affected and retain their previous values when an error is detected during reception or when the RE bit in SCR is cleared to 0.

If reception of the next data is completed while the RDRF flag is still set to 1, an overrun error will occur and the receive data will be lost.

**Bit 5—Overrun Error (ORER):** Indicates that an overrun error occurred during reception, causing abnormal termination.

#### Bit 5

ORER	Description
0	[Clearing condition] (Initial value)* <sup>1</sup> <p>When 0 is written to ORER after reading ORER = 1</p>
1	[Setting condition] <p>When the next serial reception is completed while RDRF = 1*<sup>2</sup></p>

Notes: \*<sup>1</sup> The ORER flag is not affected and retains its previous state when the RE bit in SCR is cleared to 0.

\*<sup>2</sup> The receive data prior to the overrun error is retained in RDR, and the data received subsequently is lost. Also, subsequent serial reception cannot be continued while the ORER flag is set to 1. In clocked synchronous mode, serial transmission cannot be continued, either.

**Bit 4—Framing Error (FER):** Indicates that a framing error occurred during reception in asynchronous mode, causing abnormal termination.

#### Bit 4

FER	Description
0	[Clearing condition] (Initial value)* <sup>1</sup> When 0 is written to FER after reading FER = 1
1	[Setting condition] When the SCI checks whether the stop bit at the end of the receive data when reception ends, and the stop bit is 0 * <sup>2</sup>

Notes: \*1 The FER flag is not affected and retains its previous state when the RE bit in SCR is cleared to 0.

\*2 In 2-stop-bit mode, only the first stop bit is checked for a value of 1; the second stop bit is not checked. If a framing error occurs, the receive data is transferred to RDR but the RDRF flag is not set. Also, subsequent serial reception cannot be continued while the FER flag is set to 1. In clocked synchronous mode, serial transmission cannot be continued, either.

**Bit 3—Parity Error (PER):** Indicates that a parity error occurred during reception using parity addition in asynchronous mode, causing abnormal termination.

#### Bit 3

PER	Description
0	[Clearing condition] (Initial value)* <sup>1</sup> When 0 is written to PER after reading PER = 1
1	[Setting condition] When, in reception, the number of 1 bits in the receive data plus the parity bit does not match the parity setting (even or odd) specified by the O/ $\bar{E}$ bit in SMR* <sup>2</sup>

Notes: \*1 The PER flag is not affected and retains its previous state when the RE bit in SCR is cleared to 0.

\*2 If a parity error occurs, the receive data is transferred to RDR but the RDRF flag is not set. Also, subsequent serial reception cannot be continued while the PER flag is set to 1. In clocked synchronous mode, serial transmission cannot be continued, either.

**Bit 2—Transmit End (TEND):** Indicates that there is no valid data in TDR when the last bit of the transmit character is sent, and transmission has been ended.

The TEND flag is read-only and cannot be modified.

#### Bit 2

TEND	Description
0	[Clearing conditions] <ul style="list-style-type: none"> <li>When 0 is written to TDRE after reading TDRE = 1</li> <li>When the DTC is activated by a TXI interrupt and writes data to TDR</li> </ul>
1	[Setting conditions] (Initial value) <ul style="list-style-type: none"> <li>When the TE bit in SCR is 0</li> <li>When TDRE = 1 at transmission of the last bit of a 1-byte serial transmit character</li> </ul>

**Bit 1—Multiprocessor Bit (MPB):** When reception is performed using multiprocessor format in asynchronous mode, MPB stores the multiprocessor bit in the receive data.

MPB is a read-only bit, and cannot be modified.

#### Bit 1

MPB	Description
0	[Clearing condition] (Initial value)* When data with a 0 multiprocessor bit is received
1	[Setting condition] When data with a 1 multiprocessor bit is received

Note: \*Retains its previous state when the RE bit in SCR is cleared to 0 with multiprocessor format.

**Bit 0—Multiprocessor Bit Transfer (MPBT):** When transmission is performed using multiprocessor format in asynchronous mode, MPBT stores the multiprocessor bit to be added to the transmit data.

The MPBT bit setting is invalid when multiprocessor format is not used, when not transmitting, and in clocked synchronous mode.

#### Bit 0

MPBT	Description
0	Data with a 0 multiprocessor bit is transmitted (Initial value)
1	Data with a 1 multiprocessor bit is transmitted

### 13.2.8 Bit Rate Register (BRR)

Bit	:	7	6	5	4	3	2	1	0
Initial value	:	1	1	1	1	1	1	1	1
R/W	:	R/W	R/W	R/W	R/W	R/W	R/W	R/W	R/W

BRR is an 8-bit register that sets the serial transfer bit rate in accordance with the baud rate generator operating clock selected by bits CKS1 and CKS0 in SMR.

BRR can be read or written to by the CPU at all times.

BRR is initialized to H'FF by a reset and in hardware standby mode. It retains its previous state in module stop mode, software standby mode, watch mode, subactive mode, and subsleep mode.

As baud rate generator control is performed independently for each channel, different values can be set for each channel.

Table 13.3 shows sample BRR settings in asynchronous mode, and table 13.4 shows sample BRR settings in clocked synchronous mode.

**Table 13.3 BRR Settings for Various Bit Rates (Asynchronous Mode)**

Bit Rate (bit/s)	$\phi = 2 \text{ MHz}$			$\phi = 2.097152 \text{ MHz}$			$\phi = 2.4576 \text{ MHz}$			$\phi = 3 \text{ MHz}$		
	n	N	Error (%)	n	N	Error (%)	n	N	Error (%)	n	N	Error (%)
110	1	141	0.03	1	148	-0.04	1	174	-0.26	1	212	0.03
150	1	103	0.16	1	108	0.21	1	127	0.00	1	155	0.16
300	0	207	0.16	0	217	0.21	0	255	0.00	1	77	0.16
600	0	103	0.16	0	108	0.21	0	127	0.00	0	155	0.16
1200	0	51	0.16	0	54	-0.70	0	63	0.00	0	77	0.16
2400	0	25	0.16	0	26	1.14	0	31	0.00	0	38	0.16
4800	0	12	0.16	0	13	-2.48	0	15	0.00	0	19	-2.34
9600	—	—	—	0	6	-2.48	0	7	0.00	0	9	-2.34
19200	—	—	—	—	—	—	0	3	0.00	0	4	-2.34
31250	0	1	0.00	—	—	—	—	—	—	0	2	0.00
38400	—	—	—	—	—	—	0	1	0.00	—	—	—

Bit Rate (bit/s)	$\phi = 3.6864 \text{ MHz}$			$\phi = 4 \text{ MHz}$			$\phi = 4.9152 \text{ MHz}$			$\phi = 5 \text{ MHz}$		
	n	N	Error (%)	n	N	Error (%)	n	N	Error (%)	n	N	Error (%)
110	2	64	0.70	2	70	0.03	2	86	0.31	2	88	-0.25
150	1	191	0.00	1	207	0.16	1	255	0.00	2	64	0.16
300	1	95	0.00	1	103	0.16	1	127	0.00	1	129	0.16
600	0	191	0.00	0	207	0.16	0	255	0.00	1	64	0.16
1200	0	95	0.00	0	103	0.16	0	127	0.00	0	129	0.16
2400	0	47	0.00	0	51	0.16	0	63	0.00	0	64	0.16
4800	0	23	0.00	0	25	0.16	0	31	0.00	0	32	-1.36
9600	0	11	0.00	0	12	0.16	0	15	0.00	0	15	1.73
19200	0	5	0.00	—	—	—	0	7	0.00	0	7	1.73
31250	—	—	—	0	3	0.00	0	4	-1.70	0	4	0.00
38400	0	2	0.00	—	—	—	0	3	0.00	0	3	1.73

Bit Rate (bit/s)	$\phi = 6 \text{ MHz}$			$\phi = 6.144 \text{ MHz}$			$\phi = 7.3728 \text{ MHz}$			$\phi = 8 \text{ MHz}$		
	n	N	Error (%)	n	N	Error (%)	n	N	Error (%)	n	N	Error (%)
110	2	106	-0.44	2	108	0.08	2	130	-0.07	2	141	0.03
150	2	77	0.16	2	79	0.00	2	95	0.00	2	103	0.16
300	1	155	0.16	1	159	0.00	1	191	0.00	1	207	0.16
600	1	77	0.16	1	79	0.00	1	95	0.00	1	103	0.16
1200	0	155	0.16	0	159	0.00	0	191	0.00	0	207	0.16
2400	0	77	0.16	0	79	0.00	0	95	0.00	0	103	0.16
4800	0	38	0.16	0	39	0.00	0	47	0.00	0	51	0.16
9600	0	19	-2.34	0	19	0.00	0	23	0.00	0	25	0.16
19200	0	9	-2.34	0	9	0.00	0	11	0.00	0	12	0.16
31250	0	5	0.00	0	5	2.40	—	—	—	0	7	0.00
38400	0	4	-2.34	0	4	0.00	0	5	0.00	—	—	—

Bit Rate (bit/s)	$\phi = 9.8304 \text{ MHz}$			$\phi = 10 \text{ MHz}$			$\phi = 12 \text{ MHz}$			$\phi = 12.288 \text{ MHz}$		
	n	N	Error (%)	n	N	Error (%)	n	N	Error (%)	n	N	Error (%)
110	2	174	-0.26	2	177	-0.25	2	212	0.03	2	217	0.08
150	2	127	0.00	2	129	0.16	2	155	0.16	2	159	0.00
300	1	255	0.00	2	64	0.16	2	77	0.16	2	79	0.00
600	1	127	0.00	1	129	0.16	1	155	0.16	1	159	0.00
1200	0	255	0.00	1	64	0.16	1	77	0.16	1	79	0.00
2400	0	127	0.00	0	129	0.16	0	155	0.16	0	159	0.00
4800	0	63	0.00	0	64	0.16	0	77	0.16	0	79	0.00
9600	0	31	0.00	0	32	-1.36	0	38	0.16	0	39	0.00
19200	0	15	0.00	0	15	1.73	0	19	-2.34	0	19	0.00
31250	0	9	-1.70	0	9	0.00	0	11	0.00	0	11	2.40
38400	0	7	0.00	0	7	1.73	0	9	-2.34	0	9	0.00

**Table 13.4 BRR Settings for Various Bit Rates (Clocked Synchronous Mode)**

Bit Rate (bit/s)	ø = 2 MHz		ø = 4 MHz		ø = 6 MHz		ø = 8 MHz		ø = 10 MHz	
	n	N	n	N	n	N	n	N	n	N
110	3	70	—	—						
250	2	124	2	249			3	124	—	—
500	1	249	2	124			2	249	—	—
1 k	1	124	1	249			2	124	—	—
2.5 k	0	199	1	99	1	149	1	199	1	249
5 k	0	99	0	199	1	74	1	99	1	124
10 k	0	49	0	99	0	149	0	199	0	249
25 k	0	19	0	39	0	59	0	79	0	99
50 k	0	9	0	19	0	29	0	39	0	49
100 k	0	4	0	9	0	14	0	19	0	24
250 k	0	1	0	3	0	5	0	7	0	9
500 k	0	0*	0	1	0	2	0	3	0	4
1 M			0	0*			0	1		
2.5 M									0	0*
5 M										

Note: As far as possible, the setting should be made so that the error is no more than 1%.

**Legend**

Blank : Cannot be set.

— : Can be set, but there will be a degree of error.

\* : Continuous transfer is not possible.

The BRR setting is found from the following formulas.

Asynchronous mode:

$$N = \frac{\phi}{64 \times 2^{2n-1} \times B} \times 10^6 - 1$$

Clocked synchronous mode:

$$N = \frac{\phi}{8 \times 2^{2n-1} \times B} \times 10^6 - 1$$

Where B: Bit rate (bit/s)

N: BRR setting for baud rate generator ( $0 \leq N \leq 255$ )

$\phi$ : Operating frequency (MHz)

n: Baud rate generator input clock (n = 0 to 3)

(See the table below for the relation between n and the clock.)

n	Clock	SMR Setting	
		CKS1	CKS0
0	$\phi$	0	0
1	$\phi/4$	0	1
2	$\phi/16$	1	0
3	$\phi/64$	1	1

The bit rate error in asynchronous mode is found from the following formula:

$$\text{Error (\%)} = \left\{ \frac{\phi \times 10^6}{(N + 1) \times B \times 64 \times 2^{2n-1}} - 1 \right\} \times 100$$



Table 13.5 shows the maximum bit rate for each frequency in asynchronous mode. Tables 13.6 and 13.7 show the maximum bit rates with external clock input.

**Table 13.5 Maximum Bit Rate for Each Frequency (Asynchronous Mode)**

<b>ø (MHz)</b>	<b>Maximum Bit Rate (bit/s)</b>	<b>n</b>	<b>N</b>
2	62500	0	0
2.097152	65536	0	0
2.4576	76800	0	0
3	93750	0	0
3.6864	115200	0	0
4	125000	0	0
4.9152	153600	0	0
5	156250	0	0
6	187500	0	0
6.144	192000	0	0
7.3728	230400	0	0
8	250000	0	0
9.8304	307200	0	0
10	312500	0	0
12	375000	0	0
12.288	384000	0	0

**Table 13.6 Maximum Bit Rate with External Clock Input (Asynchronous Mode)**

<b>ø (MHz)</b>	<b>External Input Clock (MHz)</b>	<b>Maximum Bit Rate (bit/s)</b>
2	0.5000	31250
2.097152	0.5243	32768
2.4576	0.6144	38400
3	0.7500	46875
3.6864	0.9216	57600
4	1.0000	62500
4.9152	1.2288	76800
5	1.2500	78125
6	1.5000	93750
6.144	1.5360	96000
7.3728	1.8432	115200
8	2.0000	125000
9.8304	2.4576	153600
10	2.5000	156250
12	3.0000	187500
12.288	3.0720	192000

**Table 13.7 Maximum Bit Rate with External Clock Input (Clock Synchronous Mode)**

<b>ø (MHz)</b>	<b>External Input Clock (MHz)</b>	<b>Maximum Bit Rate (bit/s)</b>
2	0.3333	333333.3
4	0.6667	666666.7
6	1.0000	1000000.0
8	1.3333	1333333.3
10	1.6667	1666666.7
12	2.0000	2000000.0

### 13.2.9 Smart Card Mode Register (SCMR)

Bit	:	7	6	5	4	3	2	1	0
		—	—	—	—	SDIR	—	—	—
Initial value	:	1	1	1	1	0	0	1	0
R/W	:	—	—	—	—	R/W	R/W	—	R/W

SCMR selects LSB-first or MSB-first by means of bit SDIR. Except in the case of asynchronous mode 7-bit data, LSB-first or MSB-first can be selected regardless of the serial communication mode. The descriptions in this chapter refer to LSB-first transfer.

SCMR is initialized to H'F2 by a reset and in hardware standby mode. It retains its previous state in module stop mode, software standby mode, watch mode, subactive mode, and subsleep mode.

**Bits 7 to 4—Reserved:** These bits cannot be modified and are always read as 1.

**Bit 3—Smart Card Data Transfer Direction (SDIR):** Selects the serial/parallel conversion format.

This bit is valid when 8-bit data is used as the transmit/receive format.

#### Bit 3

SDIR	Description
0	TDR contents are transmitted LSB-first Receive data is stored in RDR LSB-first (Initial value)
1	TDR contents are transmitted MSB-first Receive data is stored in RDR MSB-first

**Bits 2 and 0—Reserved:** Only 0 should be written to these bits.

**Bit 1—Reserved:** This bit cannot be modified and is always read as 1.

## 13.2.10 Module Stop Control Registers B and C (MSTPCRB, MSTPCRC)

### MSTPCRB

Bit	:	7	6	5	4	3	2	1	0
		MSTPB7	MSTPB6	MSTPB5	MSTPB4	MSTPB3	MSTPB2	MSTPB1	MSTPB0
Initial value	:	1	1	1	1	1	1	1	1
R/W	:	R/W	R/W	R/W	R/W	R/W	R/W	R/W	R/W

### MSTPCRC

Bit	:	7	6	5	4	3	2	1	0
		MSTPC7	MSTPC6	MSTPC5	MSTPC4	MSTPC3	MSTPC2	MSTPC1	MSTPC0
Initial value	:	1	1	1	1	1	1	1	1
R/W	:	R/W	R/W	R/W	R/W	R/W	R/W	R/W	R/W

MSTPCRB and MSTPCRC are 8-bit readable/writable registers that perform module stop mode control.

When one of bits MSTPB7, MSTPB6, or MSTPC7 is set to 1, SCI0, SCI1, or SCI3, respectively, stops operation at the end of the bus cycle, and enters module stop mode. For details, see section 19.5, Module Stop Mode.

MSTPCRB and MSTPCRC are each initialized to H'FF by a reset and in hardware standby mode. They are not initialized in software standby mode.

### Module Stop Control Register B (MSTPCRB)

**Bit 7—Module Stop (MSTPB7):** Specifies the SCI0 module stop mode.

#### Bit 7

MSTPB7	Description
0	SCI0 module stop mode is cleared
1	SCI0 module stop mode is set (Initial value)

**Bit 6—Module Stop (MSTPB6):** Specifies the SCI1 module stop mode.

#### Bit 6

MSTPB6	Description
0	SCI1 module stop mode is cleared
1	SCI1 module stop mode is set (Initial value)

**Bit 5—Reserved:** Only 1 should be written to this bit.

### Module Stop Control Register C (MSTPCRC)

**Bit 7—Module Stop (MSTPC7):** Specifies the SCI3 module stop mode.

#### Bit 7

<b>MSTPC7</b>	<b>Description</b>	
0	SCI3 module stop mode is cleared	
1	SCI3 module stop mode is set	(Initial value)

## 13.3 Operation

### 13.3.1 Overview

The SCI can carry out serial communication in two modes: asynchronous mode in which synchronization is achieved character by character, and clocked synchronous mode in which synchronization is achieved with clock pulses.

Selection of asynchronous or clocked synchronous mode and the transmission format is made using SMR as shown in table 13.8. The SCI clock is determined by a combination of the  $C/\bar{A}$  bit in SMR and the CKE1 and CKE0 bits in SCR, as shown in table 13.9.

#### Asynchronous Mode

- Data length: Choice of 7 or 8 bits
- Choice of parity addition, multiprocessor bit addition, and addition of 1 or 2 stop bits (the combination of these parameters determines the transfer format and character length)
- Detection of framing, parity, and overrun errors, and breaks, during reception
- Choice of internal or external clock as SCI clock source
  - When internal clock is selected:

The SCI operates on the baud rate generator clock and a clock with the same frequency as the bit rate can be output
  - When external clock is selected:

A clock with a frequency of 16 times the bit rate must be input (the on-chip baud rate generator is not used)

#### Clocked Synchronous Mode

- Transfer format: Fixed 8-bit data
- Detection of overrun errors during reception
- Choice of internal or external clock as SCI clock source
  - When internal clock is selected:

The SCI operates on the baud rate generator clock and a serial clock is output off-chip
  - When external clock is selected:

The on-chip baud rate generator is not used, and the SCI operates on the input serial clock

**Table 13.8 SMR Settings and Serial Transfer Format Selection**

SMR Settings						SCI Transfer Format									
Bit 7	Bit 6	Bit 2	Bit 5	Bit 3	Mode	Data Length	Multi-processor Bit	Parity Bit	Stop Bit Length						
C/ $\bar{A}$	CHR	MP	PE	STOP											
0	0	0	0	0	Asynchronous mode	8-bit data	No	No	1 bit						
				1					2 bits						
				0	Asynchronous mode (multi-processor format)				7-bit data	Yes	No	1 bit			
				1								2 bits			
				1	Asynchronous mode (multi-processor format)							7-bit data	No	No	1 bit
				0											2 bits
	0	Asynchronous mode (multi-processor format)	7-bit data	Yes	No	1 bit									
	1					2 bits									
	1	Asynchronous mode (multi-processor format)				7-bit data	No	No	1 bit						
	0								2 bits						
	1	—							—	—	—	Clocked synchronous mode	8-bit data	No	None

**Table 13.9 SMR and SCR Settings and SCI Clock Source Selection**

SMR		SCR Setting		SCI Transmit/Receive Clock		
Bit 7	Bit 1	Bit 0	Mode	Clock Source	SCK Pin Function	
C/ $\bar{A}$	CKE1	CKE0				
0	0	0	Asynchronous mode	Internal	SCI does not use SCK pin	
		1				Outputs clock with same frequency as bit rate
	1	0	Clocked synchronous mode		External	Inputs clock with frequency of 16 times the bit rate
		1				
1	0	0	Clocked synchronous mode	Internal		Outputs serial clock
		1				
	1	0	Clocked synchronous mode		External	Inputs serial clock
		1				

### 13.3.2 Operation in Asynchronous Mode

In asynchronous mode, characters are sent or received, each preceded by a start bit indicating the start of communication and stop bits indicating the end of communication. Serial communication is thus carried out with synchronization established on a character-by-character basis.

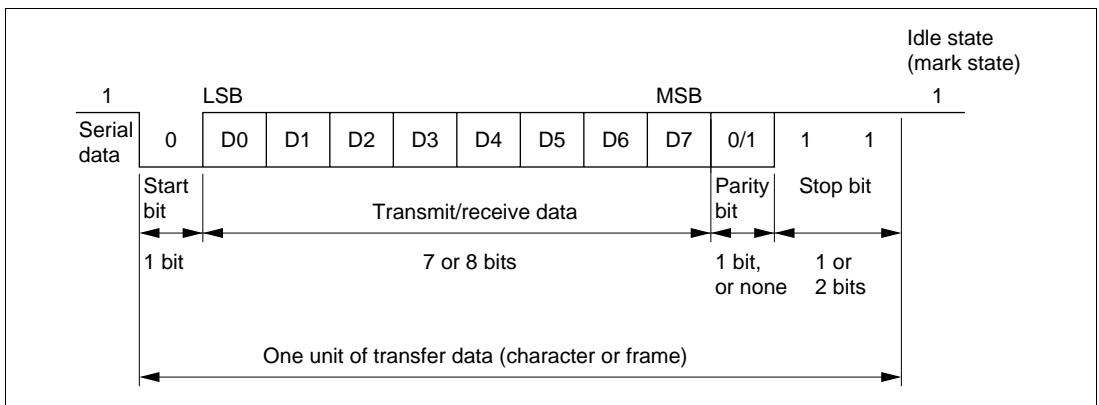
Inside the SCI, the transmitter and receiver are independent units, enabling full-duplex communication. Both the transmitter and the receiver also have a double-buffered structure, so that data can be read or written during transmission or reception, enabling continuous data transfer.

Figure 13.2 shows the general format for asynchronous serial communication.

In asynchronous serial communication, the transmission line is usually held in the mark state (high level). The SCI monitors the transmission line, and when it goes to the space state (low level), recognizes a start bit and starts serial communication.

One serial communication character consists of a start bit (low level), followed by data (in LSB-first order), a parity bit (high or low level), and finally stop bits (high level).

In asynchronous mode, the SCI performs synchronization at the falling edge of the start bit in reception. The SCI samples the data on the 8th pulse of a clock with a frequency of 16 times the length of one bit, so that the transfer data is latched at the center of each bit.



**Figure 13.2 Data Format in Asynchronous Communication  
(Example with 8-Bit Data, Parity, Two Stop Bits)**



**Data Transfer Format:** Table 13.10 shows the data transfer formats that can be used in asynchronous mode. Any of 12 transfer formats can be selected according to the SMR setting.

**Table 13.10 Serial Transfer Formats (Asynchronous Mode)**

SMR Settings				Serial Transfer Format and Frame Length												
CHR	PE	MP	STOP	1	2	3	4	5	6	7	8	9	10	11	12	
0	0	0	0	S	8-bit data								STOP			
0	0	0	1	S	8-bit data								STOP	STOP		
0	1	0	0	S	8-bit data								P	STOP		
0	1	0	1	S	8-bit data								P	STOP	STOP	
1	0	0	0	S	7-bit data							STOP				
1	0	0	1	S	7-bit data							STOP	STOP			
1	1	0	0	S	7-bit data							P	STOP			
1	1	0	1	S	7-bit data							P	STOP	STOP		
0	—	1	0	S	8-bit data								MPB	STOP		
0	—	1	1	S	8-bit data								MPB	STOP	STOP	
1	—	1	0	S	7-bit data							MPB	STOP			
1	—	1	1	S	7-bit data							MPB	STOP	STOP		

**Legend**

S : Start bit

STOP : Stop bit

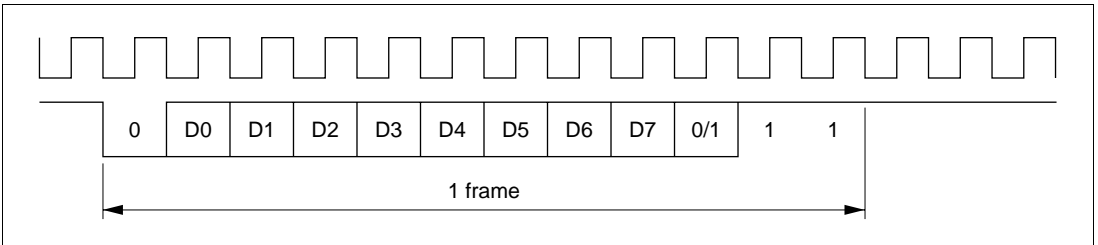
P : Parity bit

MPB : Multiprocessor bit

**Clock:** Either an internal clock generated by the on-chip baud rate generator or an external clock input at the SCK pin can be selected as the SCI's serial clock, according to the setting of the  $\overline{C/\overline{A}}$  bit in SMR and the CKE1 and CKE0 bits in SCR. For details of SCI clock source selection, see table 13.9.

When an external clock is input at the SCK pin, the clock frequency should be 16 times the bit rate used.

When the SCI is operated on an internal clock, the clock can be output from the SCK pin. The frequency of the clock output in this case is equal to the bit rate, and the phase is such that the rising edge of the clock is in the middle of the transmit data, as shown in figure 13.3.



**Figure 13.3 Relation between Output Clock and Transfer Data Phase (Asynchronous Mode)**

### Data Transfer Operations:

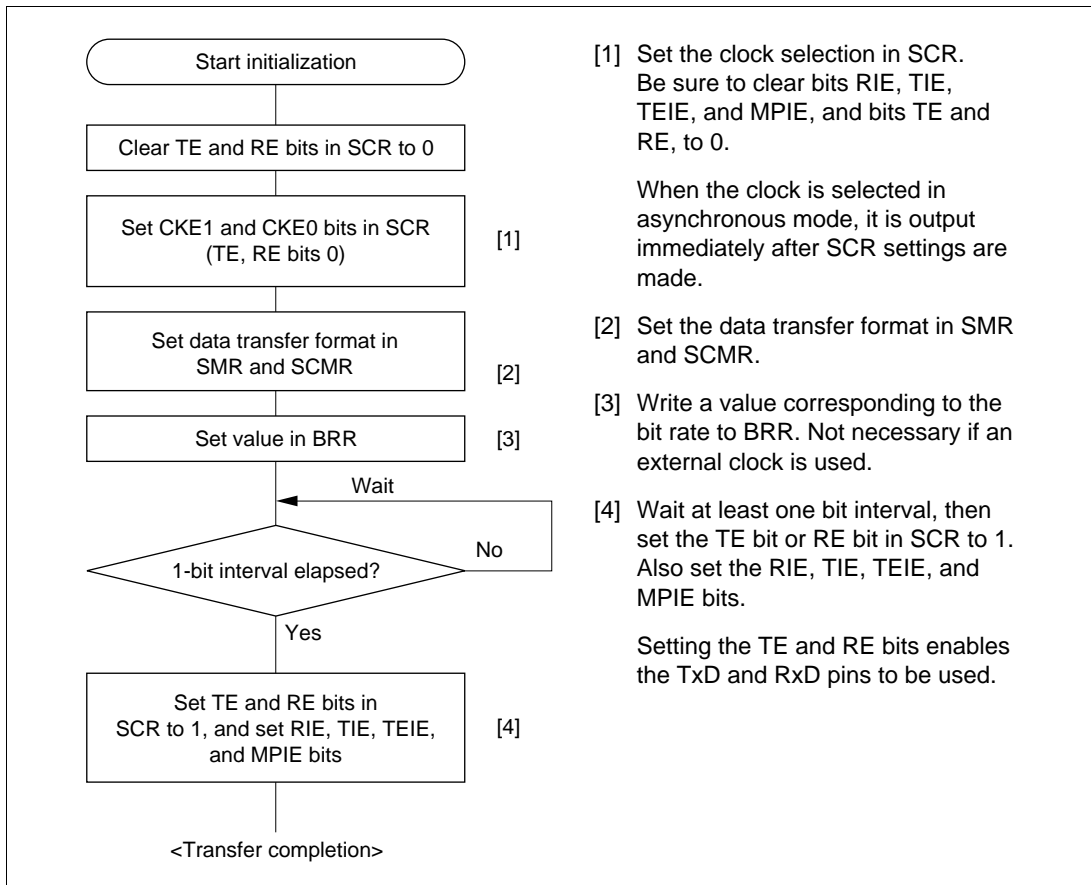
- SCI initialization (asynchronous mode)

Before transmitting and receiving data, you should first clear the TE and RE bits in SCR to 0, then initialize the SCI as described below.

When the operating mode, transfer format, etc., is changed, the TE and RE bits must be cleared to 0 before making the change using the following procedure. When the TE bit is cleared to 0, the TDRE flag is set to 1 and TSR is initialized. Note that clearing the RE bit to 0 does not change the contents of the RDRF, PER, FER, and ORER flags, or the contents of RDR.

When an external clock is used the clock should not be stopped during operation, including initialization, since operation is uncertain.

Figure 13.4 shows a sample SCI initialization flowchart.

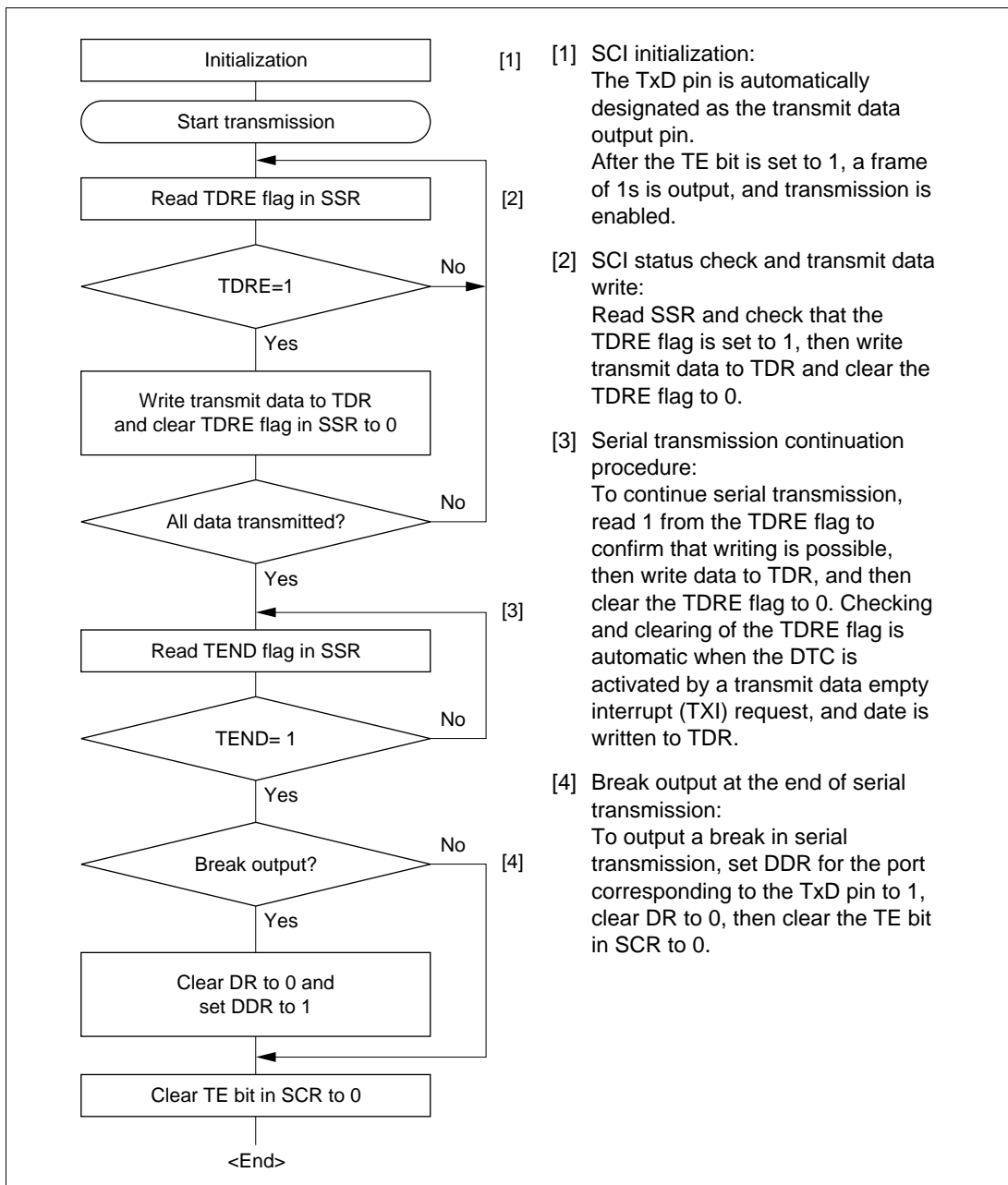


**Figure 13.4 Sample SCI Initialization Flowchart**

- Serial data transmission (asynchronous mode)

Figure 13.5 shows a sample flowchart for serial transmission.

The following procedure should be used for serial data transmission.



**Figure 13.5 Sample Serial Transmission Flowchart**

In serial transmission, the SCI operates as described below.

[1] The SCI monitors the TDRE flag in SSR, and if is 0, recognizes that data has been written to TDR, and transfers the data from TDR to TSR.

[2] After transferring data from TDR to TSR, the SCI sets the TDRE flag to 1 and starts transmission.

If the TIE bit is set to 1 at this time, a transmit data empty interrupt (TXI) is generated.

The serial transmit data is sent from the TxD pin in the following order.

[a] Start bit:

One 0-bit is output.

[b] Transmit data:

8-bit or 7-bit data is output in LSB-first order.

[c] Parity bit or multiprocessor bit:

One parity bit (even or odd parity), or one multiprocessor bit is output.

A format in which neither a parity bit nor a multiprocessor bit is output can also be selected.

[d] Stop bit(s):

One or two 1-bits (stop bits) are output.

[e] Mark state:

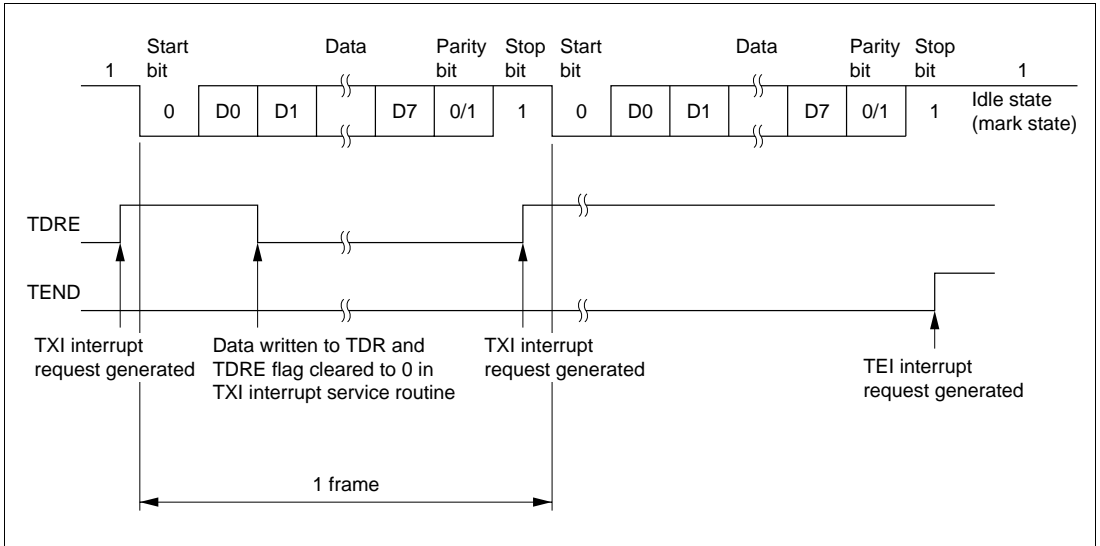
1 is output continuously until the start bit that starts the next transmission is sent.

[3] The SCI checks the TDRE flag at the timing for sending the stop bit.

If the TDRE flag is cleared to 0, the data is transferred from TDR to TSR, the stop bit is sent, and then serial transmission of the next frame is started.

If the TDRE flag is set to 1, the TEND flag in SSR is set to 1, the stop bit is sent, and then the “mark state” is entered in which 1 is output continuously. If the TEIE bit in SCR is set to 1 at this time, a TEI interrupt request is generated.

Figure 13.6 shows an example of the operation for transmission in asynchronous mode.



**Figure 13.6 Example of Operation in Transmission in Asynchronous Mode  
(Example with 8-Bit Data, Parity, One Stop Bit)**

- Serial data reception (asynchronous mode)

Figure 13.7 shows a sample flowchart for serial reception.

The following procedure should be used for serial data reception.

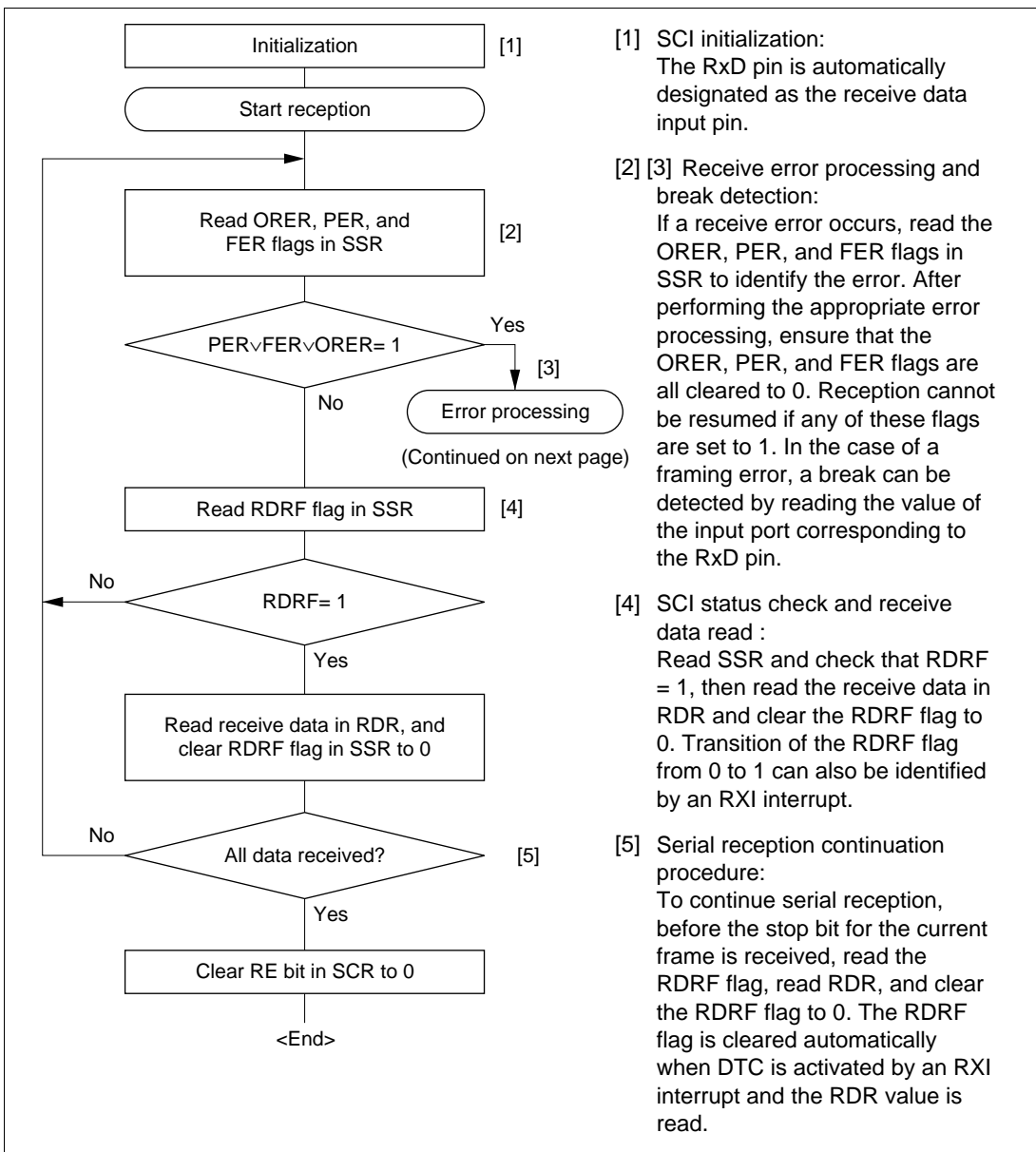
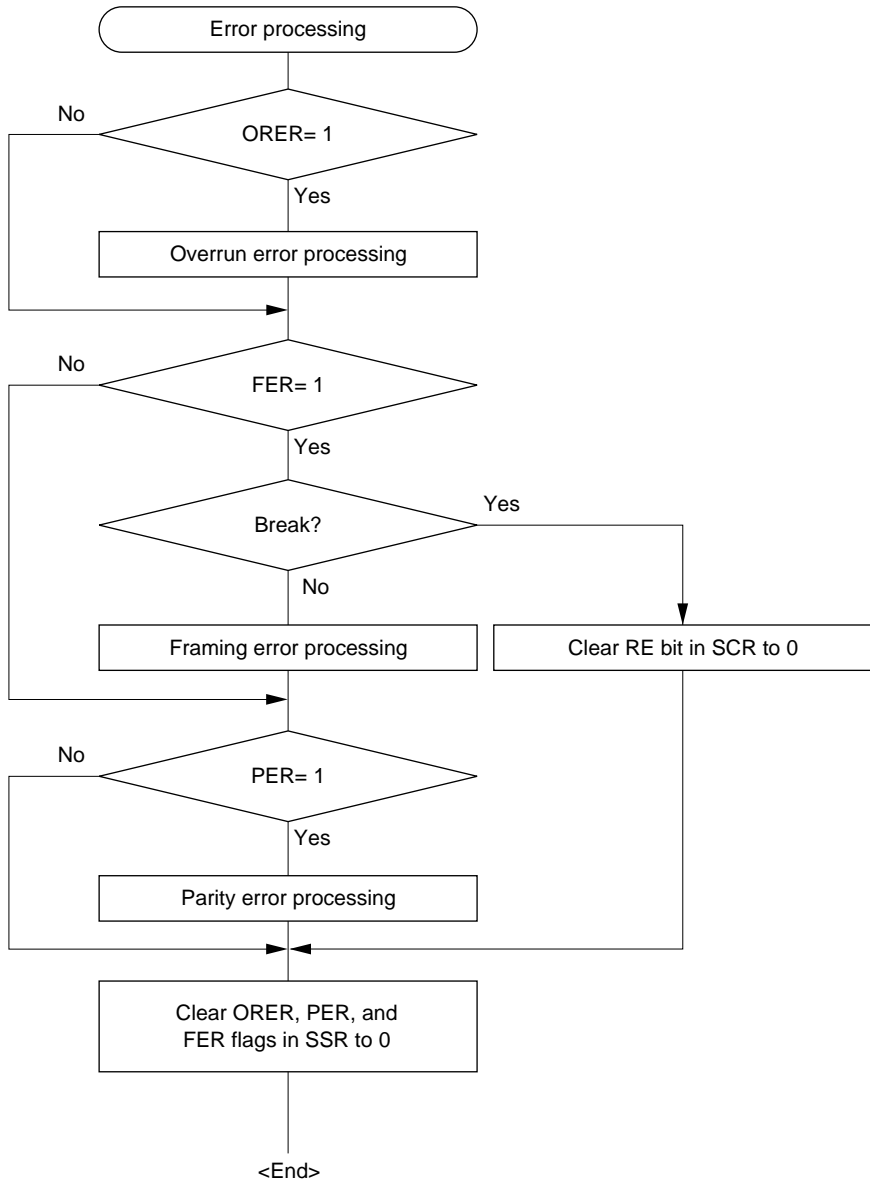


Figure 13.7 Sample Serial Reception Data Flowchart

[3]



**Figure 13.7 Sample Serial Reception Data Flowchart (cont)**



In serial reception, the SCI operates as described below.

[1] The SCI monitors the transmission line, and if a 0 stop bit is detected, performs internal synchronization and starts reception.

[2] The received data is stored in RSR in LSB-to-MSB order.

[3] The parity bit and stop bit are received.

After receiving these bits, the SCI carries out the following checks.

[a] Parity check:

The SCI checks whether the number of 1 bits in the receive data agrees with the parity (even or odd) set in the  $O/\bar{E}$  bit in SMR.

[b] Stop bit check:

The SCI checks whether the stop bit is 1.

If there are two stop bits, only the first is checked.

[c] Status check:

The SCI checks whether the RDRF flag is 0, indicating that the receive data can be transferred from RSR to RDR.

If all the above checks are passed, the RDRF flag is set to 1, and the receive data is stored in RDR.

If a receive error\* is detected in the error check, the operation is as shown in table 13.11.

Note: \* Subsequent receive operations cannot be performed when a receive error has occurred.

Also note that the RDRF flag is not set to 1 in reception, and so the error flags must be cleared to 0.

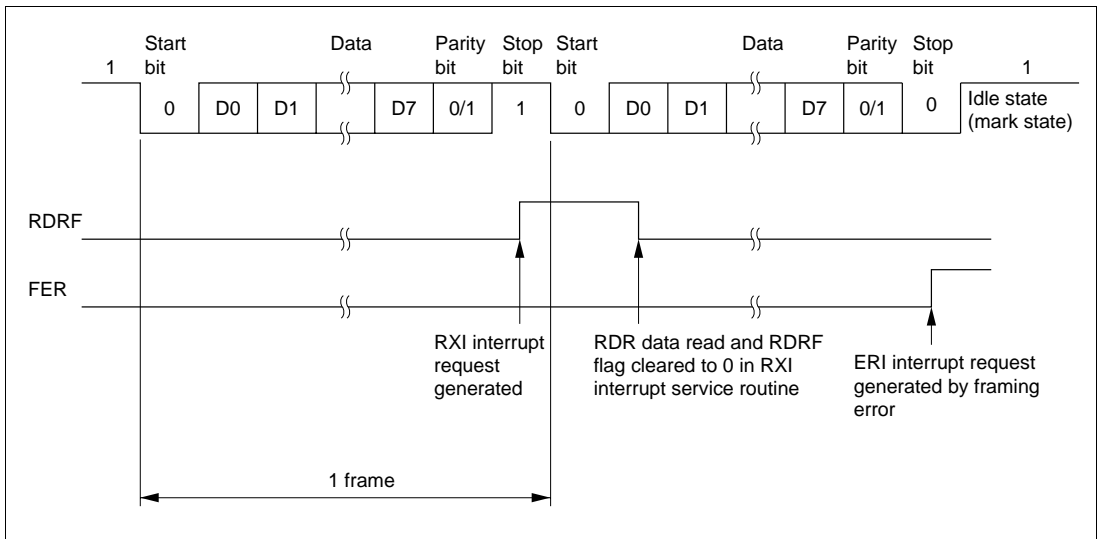
[4] If the RIE bit in SCR is set to 1 when the RDRF flag changes to 1, a receive data full interrupt (RXI) request is generated.

Also, if the RIE bit in SCR is set to 1 when the ORER, PER, or FER flag changes to 1, a receive error interrupt (ERI) request is generated.

**Table 13.11 Receive Errors and Conditions for Occurrence**

Receive Error	Abbreviation	Occurrence Condition	Data Transfer
Overrun error	ORER	When the next data reception is completed while the RDRF flag in SSR is set to 1	Receive data is not transferred from RSR to RDR.
Framing error	FER	When the stop bit is 0	Receive data is transferred from RSR to RDR.
Parity error	PER	When the received data differs from the parity (even or odd) set in SMR	Receive data is transferred from RSR to RDR.

Figure 13.8 shows an example of the operation for reception in asynchronous mode.



**Figure 13.8 Example of SCI Operation in Reception  
(Example with 8-Bit Data, Parity, One Stop Bit)**

### 13.3.3 Multiprocessor Communication Function

The multiprocessor communication function performs serial communication using the multiprocessor format, in which a multiprocessor bit is added to the transfer data, in asynchronous mode. Use of this function enables data transfer to be performed among a number of processors sharing transmission lines.

When multiprocessor communication is carried out, each receiving station is addressed by a unique ID code.

The serial communication cycle consists of two component cycles: an ID transmission cycle which specifies the receiving station, and a data transmission cycle. The multiprocessor bit is used to differentiate between the ID transmission cycle and the data transmission cycle.

The transmitting station first sends the ID of the receiving station with which it wants to perform serial communication as data with a 1 multiprocessor bit added. It then sends transmit data as data with a 0 multiprocessor bit added.

The receiving station skips the data until data with a 1 multiprocessor bit is sent.

When data with a 1 multiprocessor bit is received, the receiving station compares that data with its own ID. The station whose ID matches then receives the data sent next. Stations whose ID does not match continue to skip the data until data with a 1 multiprocessor bit is again received. In this way, data communication is carried out among a number of processors.

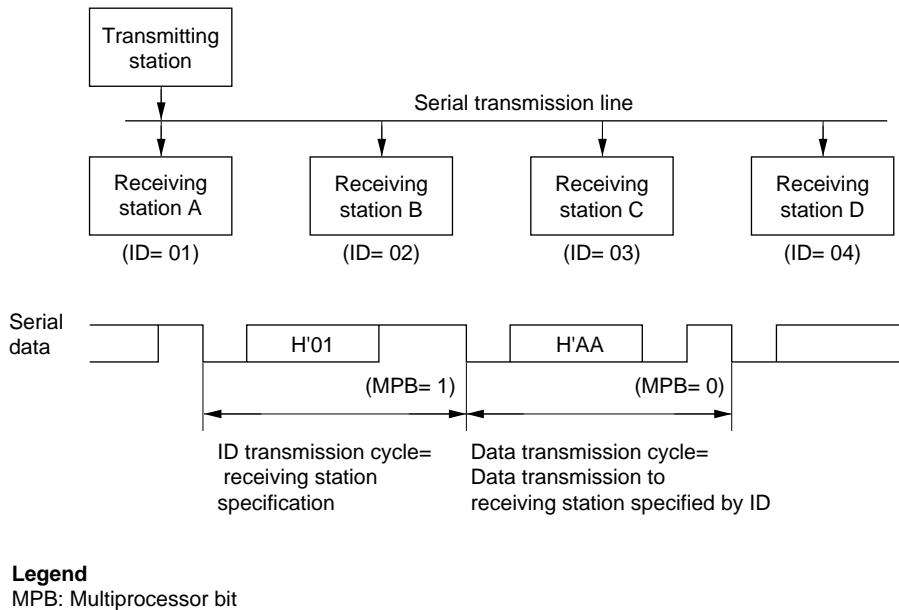
Figure 13.9 shows an example of inter-processor communication using the multiprocessor format.

**Data Transfer Format:** There are four data transfer formats.

When the multiprocessor format is specified, the parity bit specification is invalid.

For details, see table 13.10.

**Clock:** See the section on asynchronous mode.



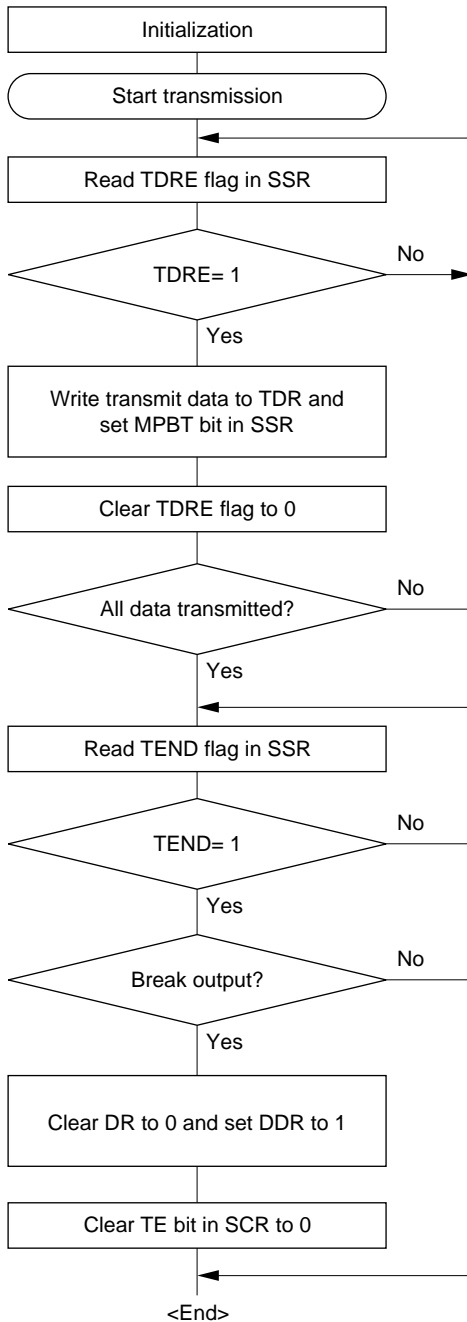
**Figure 13.9 Example of Inter-Processor Communication Using Multiprocessor Format (Transmission of Data H'AA to Receiving Station A)**

### Data Transfer Operations:

- Multiprocessor serial data transmission

Figure 13.10 shows a sample flowchart for multiprocessor serial data transmission.

The following procedure should be used for multiprocessor serial data transmission.



- [1] [1] SCI initialization:  
The TxD pin is automatically designated as the transmit data output pin.  
After the TE bit is set to 1, a frame of 1s is output, and transmission is enabled.
- [2] [2] SCI status check and transmit data write:  
Read SSR and check that the TDRE flag is set to 1, then write transmit data to TDR. Set the MPBT bit in SSR to 0 or 1.  
Finally, clear the TDRE flag to 0.
- [3] [3] Serial transmission continuation procedure:  
To continue serial transmission, be sure to read 1 from the TDRE flag to confirm that writing is possible, then write data to TDR, and then clear the TDRE flag to 0. Checking and clearing of the TDRE flag is automatic when the DTC is activated by a transmit data empty interrupt (TXI) request, and data is written to TDR.
- [4] [4] Break output at the end of serial transmission:  
To output a break in serial transmission, set the port DDR to 1, clear DR to 0, then clear the TE bit in SCR to 0.

**Figure 13.10 Sample Multiprocessor Serial Transmission Flowchart**

In serial transmission, the SCI operates as described below.

- [1] The SCI monitors the TDRE flag in SSR, and if it is 0, recognizes that data has been written to TDR, and transfers the data from TDR to TSR.
  - [2] After transferring data from TDR to TSR, the SCI sets the TDRE flag to 1 and starts transmission.

If the TIE bit in SCR is set to 1 at this time, a transmit data empty interrupt (TXI) is generated. The serial transmit data is sent from the TxD pin in the following order.

    - [a] Start bit:

One 0-bit is output.
    - [b] Transmit data:

8-bit or 7-bit data is output in LSB-first order.
    - [c] Multiprocessor bit  
One multiprocessor bit (MPBT value) is output.
    - [d] Stop bit(s):

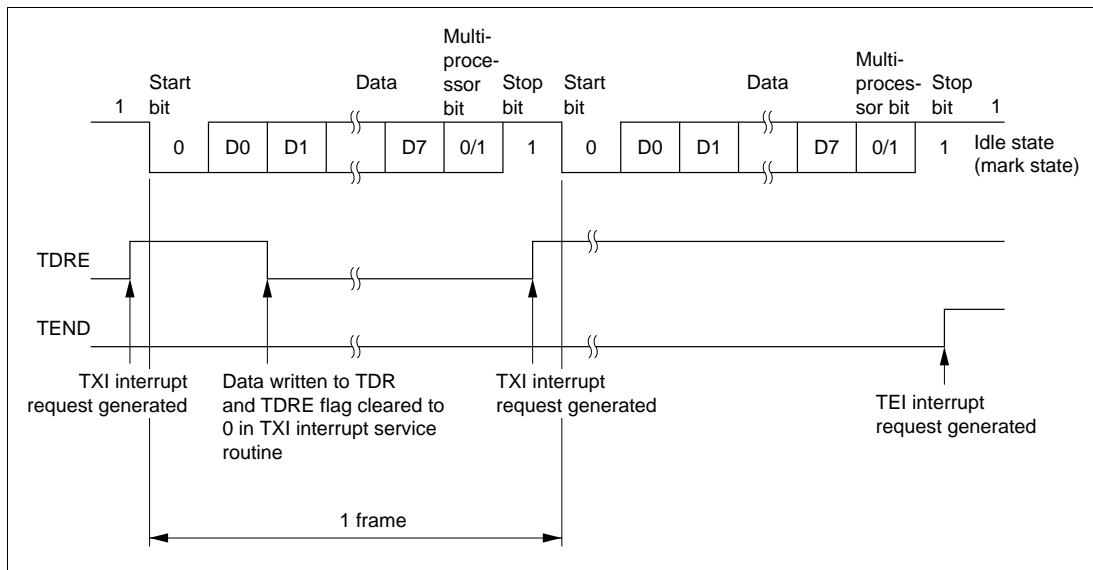
One or two 1-bits (stop bits) are output.
    - [e] Mark state:

1 is output continuously until the start bit that starts the next transmission is sent.
- [3] The SCI checks the TDRE flag at the timing for sending the stop bit.

If the TDRE flag is cleared to 0, data is transferred from TDR to TSR, the stop bit is sent, and then serial transmission of the next frame is started.

If the TDRE flag is set to 1, the TEND flag in SSR is set to 1, the stop bit is sent, and then the mark state is entered in which 1 is output continuously. If the TEIE bit in SCR is set to 1 at this time, a transmission end interrupt (TEI) request is generated.

Figure 13.11 shows an example of SCI operation for transmission using the multiprocessor format.

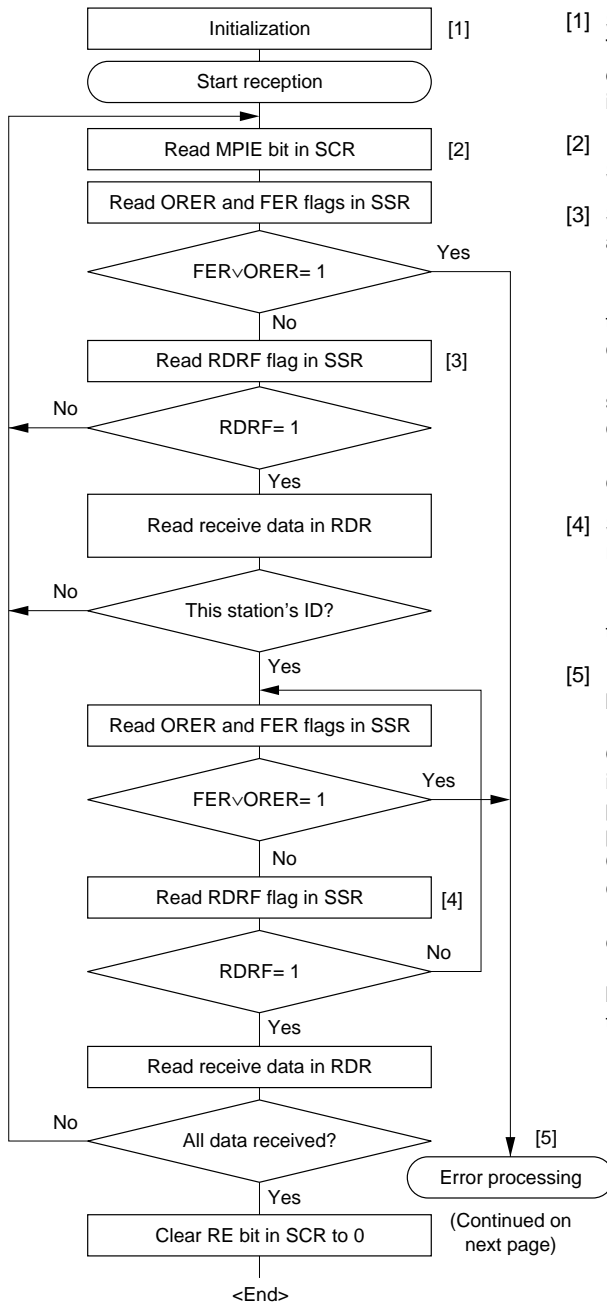


**Figure 13.11 Example of SCI Operation in Transmission  
(Example with 8-Bit Data, Multiprocessor Bit, One Stop Bit)**

- Multiprocessor serial data reception

Figure 13.12 shows a sample flowchart for multiprocessor serial reception.

The following procedure should be used for multiprocessor serial data reception.



[1] SCI initialization:  
The RxD pin is automatically designated as the receive data input pin.

[2] ID reception cycle:  
Set the MPIE bit in SCR to 1.

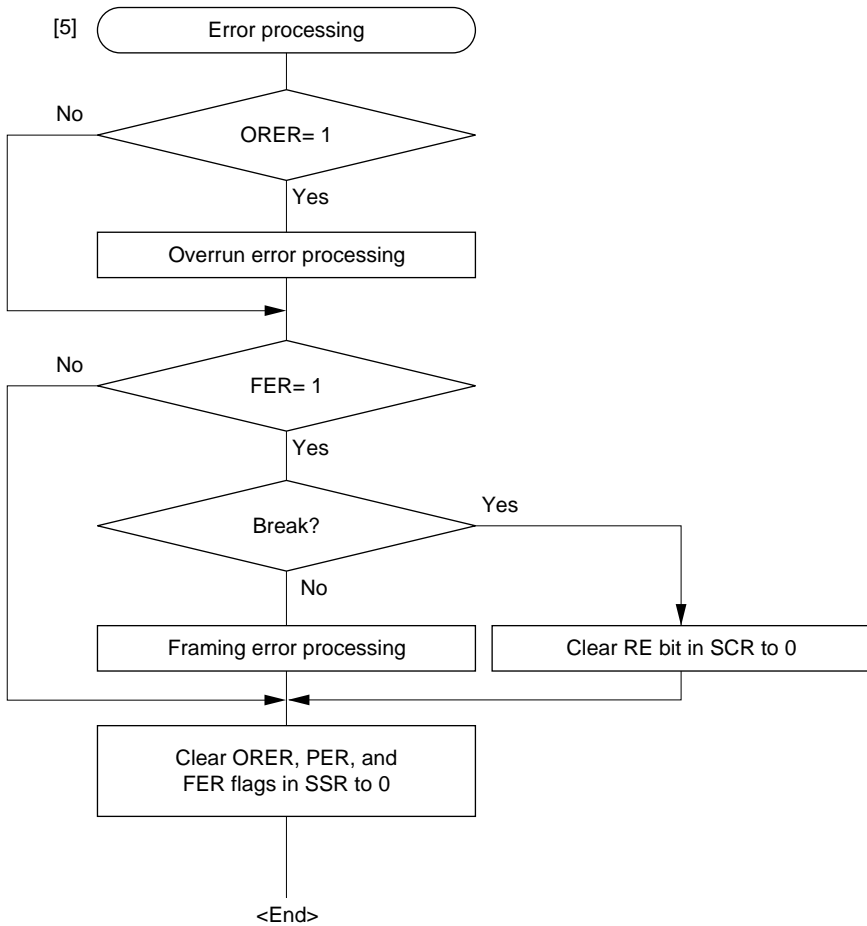
[3] SCI status check, ID reception and comparison:  
Read SSR and check that the RDRF flag is set to 1, then read the receive data in RDR and compare it with this station's ID. If the data is not this station's ID, set the MPIE bit to 1 again, and clear the RDRF flag to 0. If the data is this station's ID, clear the RDRF flag to 0.

[4] SCI status check and data reception:  
Read SSR and check that the RDRF flag is set to 1, then read the data in RDR.

[5] Receive error processing and break detection:  
If a receive error occurs, read the ORER and FER flags in SSR to identify the error. After performing the appropriate error processing, ensure that the ORER and FER flags are all cleared to 0. Reception cannot be resumed if either of these flags is set to 1. In the case of a framing error, a break can be detected by reading the RxD pin value.

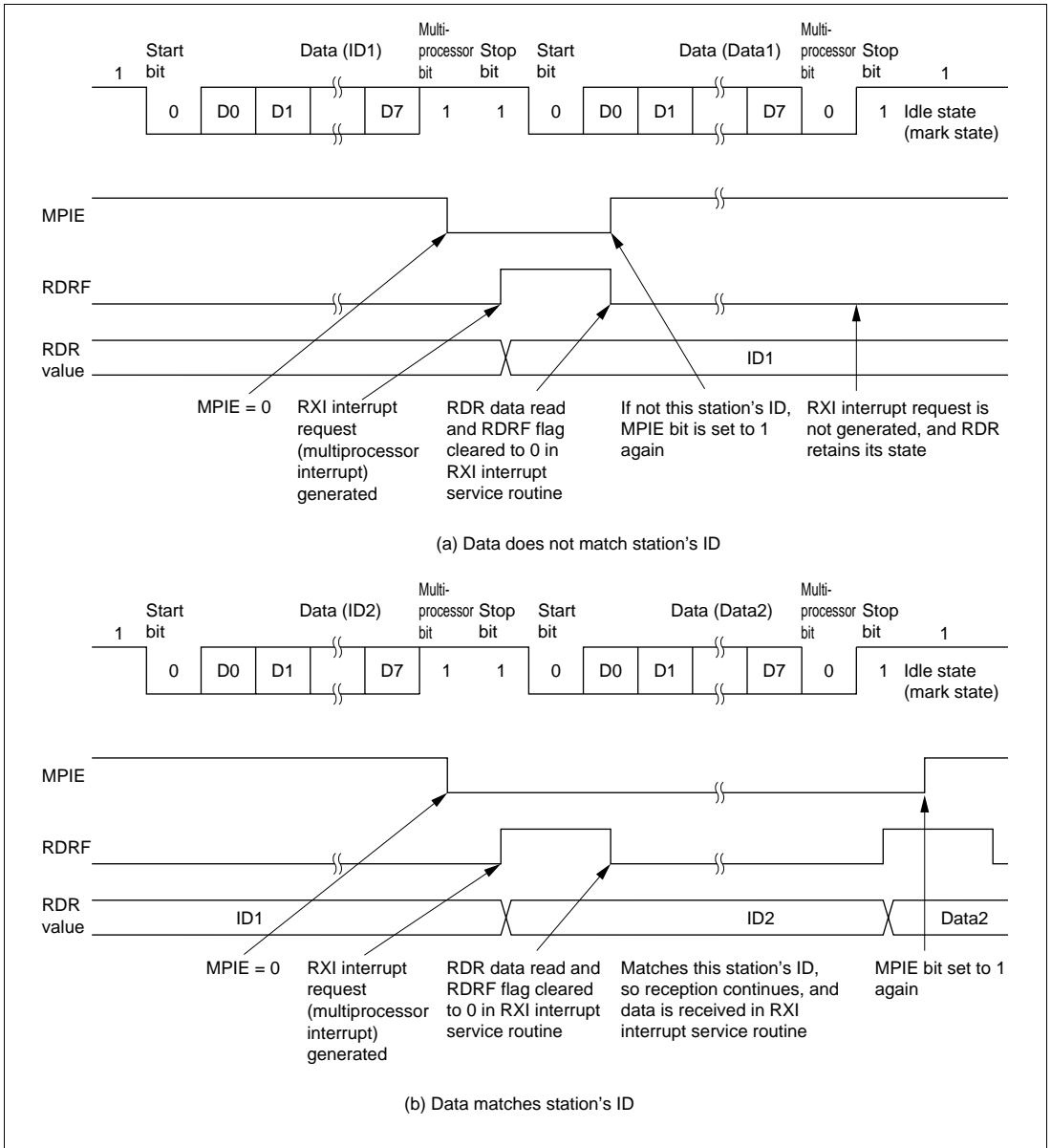
Figure 13.12 Sample Multiprocessor Serial Reception Flowchart





**Figure 13.12 Sample Multiprocessor Serial Reception Flowchart (cont)**

Figure 13.13 shows an example of SCI operation for multiprocessor format reception.



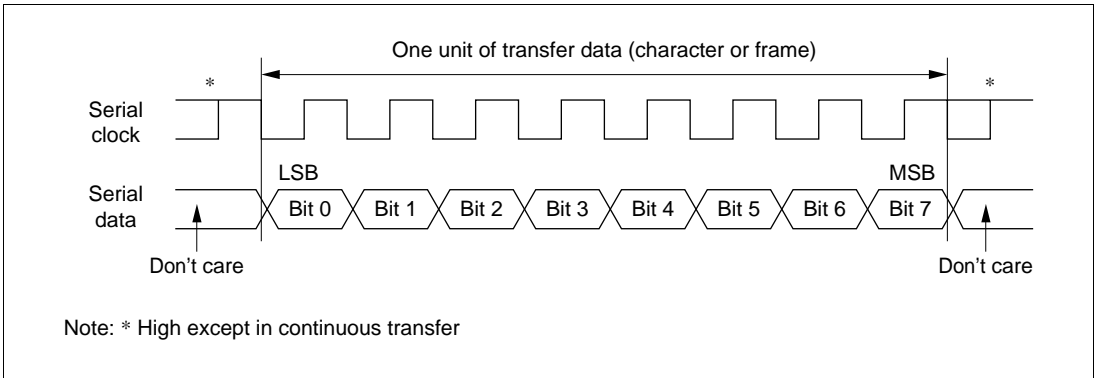
**Figure 13.13 Example of SCI Operation in Reception  
(Example with 8-Bit Data, Multiprocessor Bit, One Stop Bit)**

### 13.3.4 Operation in Clocked Synchronous Mode

In clocked synchronous mode, data is transmitted or received in synchronization with clock pulses, making it suitable for high-speed serial communication.

Inside the SCI, the transmitter and receiver are independent units, enabling full-duplex communication by use of a common clock. Both the transmitter and the receiver also have a double-buffered structure, so that data can be read or written during transmission or reception, enabling continuous data transfer.

Figure 13.14 shows the general format for clocked synchronous serial communication.



**Figure 13.14 Data Format in Synchronous Communication**

In clocked synchronous serial communication, data on the transmission line is output from one falling edge of the serial clock to the next. Data confirmation is guaranteed at the rising edge of the serial clock.

In clocked serial communication, one character consists of data output starting with the LSB and ending with the MSB. After the MSB is output, the transmission line holds the MSB state.

In clocked synchronous mode, the SCI receives data in synchronization with the rising edge of the serial clock.

**Data Transfer Format:** A fixed 8-bit data format is used.

No parity or multiprocessor bits are added.

**Clock:** Either an internal clock generated by the on-chip baud rate generator or an external serial clock input at the SCK pin can be selected, according to the setting of the C/A bit in SMR and the CKE1 and CKE0 bits in SCR. For details of SCI clock source selection, see table 13.9.

When the SCI is operated on an internal clock, the serial clock is output from the SCK pin.

Eight serial clock pulses are output in the transfer of one character, and when no transfer is performed the clock is fixed high. When only receive operations are performed, however, the serial clock is output until an overrun error occurs or the RE bit is cleared to 0. If you want to perform receive operations in units of one character, you should select an external clock as the clock source.

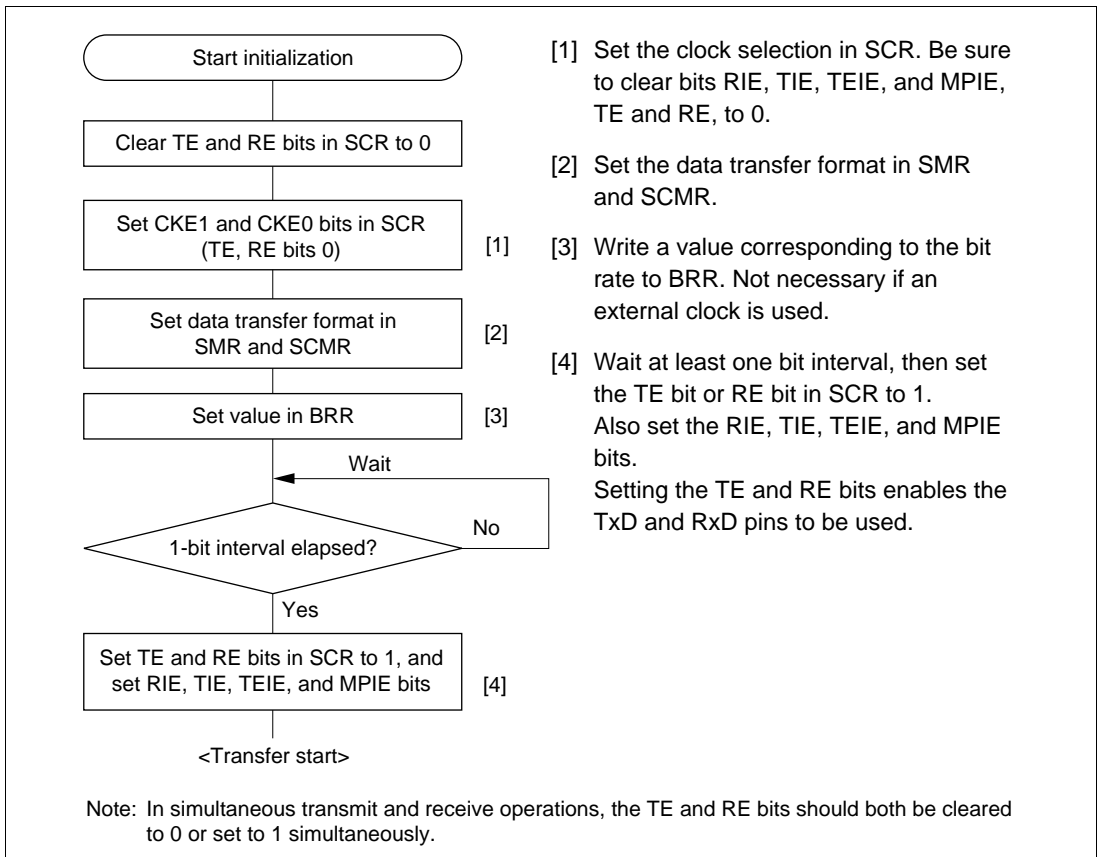
### Data Transfer Operations:

- SCI initialization (clocked synchronous mode)

Before transmitting and receiving data, you should first clear the TE and RE bits in SCR to 0, then initialize the SCI as described below.

When the operating mode, transfer format, etc., is changed, the TE and RE bits must be cleared to 0 before making the change using the following procedure. When the TE bit is cleared to 0, the TDRE flag is set to 1 and TSR is initialized. Note that clearing the RE bit to 0 does not change the contents of the RDRF, PER, FER, and ORER flags, or the contents of RDR.

Figure 13.15 shows a sample SCI initialization flowchart.

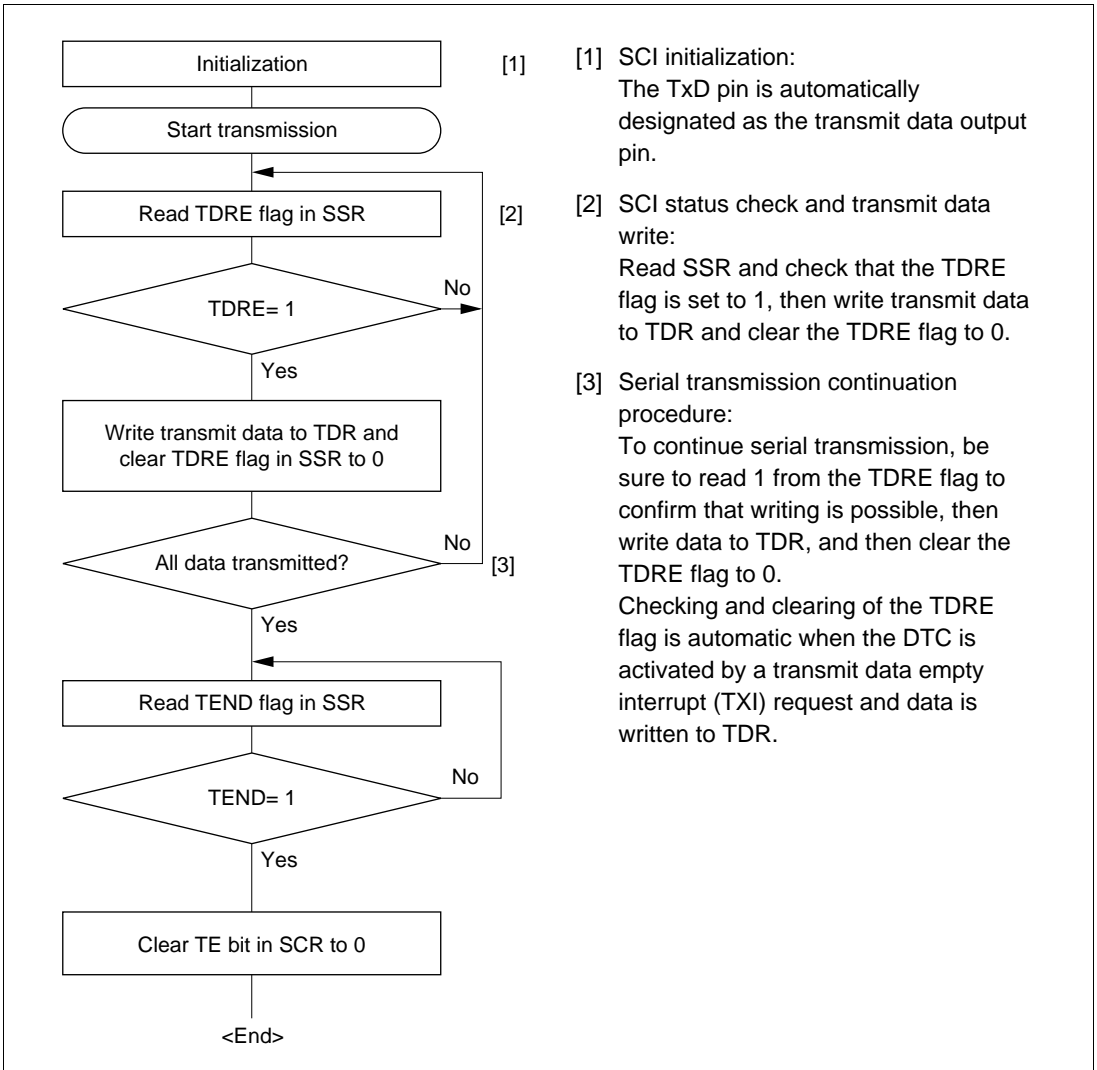


**Figure 13.15 Sample SCI Initialization Flowchart**

- Serial data transmission (clocked synchronous mode)

Figure 13.16 shows a sample flowchart for serial transmission.

The following procedure should be used for serial data transmission.



**Figure 13.16 Sample Serial Transmission Flowchart**

In serial transmission, the SCI operates as described below.

[1] The SCI monitors the TDRE flag in SSR, and if it is 0, recognizes that data has been written to TDR, and transfers the data from TDR to TSR.

[2] After transferring data from TDR to TSR, the SCI sets the TDRE flag to 1 and starts transmission. If the TIE bit in SCR is set to 1 at this time, a transmit data empty interrupt (TXI) is generated.

When clock output mode has been set, the SCI outputs 8 serial clock pulses. When use of an external clock has been specified, data is output synchronized with the input clock.

The serial transmit data is sent from the TxD pin starting with the LSB (bit 0) and ending with the MSB (bit 7).

[3] The SCI checks the TDRE flag at the timing for sending the MSB (bit 7).

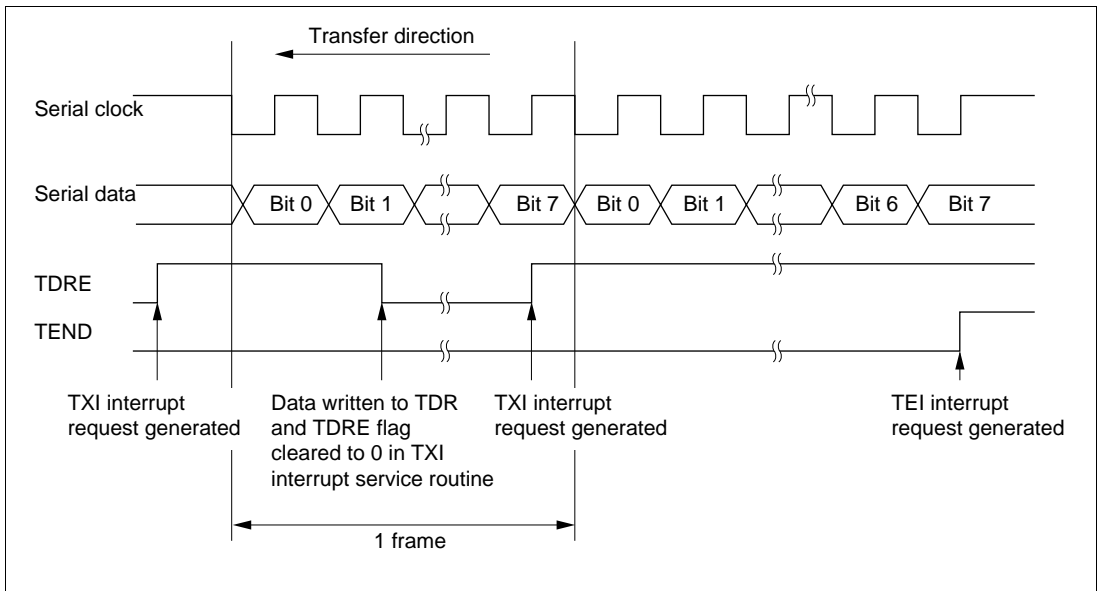
If the TDRE flag is cleared to 0, data is transferred from TDR to TSR, and serial transmission of the next frame is started.

If the TDRE flag is set to 1, the TEND flag in SSR is set to 1, the MSB (bit 7) is sent, and the TxD pin maintains its state.

If the TEIE bit in SCR is set to 1 at this time, a TEI interrupt request is generated.

[4] After completion of serial transmission, the SCK pin is fixed.

Figure 13.17 shows an example of SCI operation in transmission.



**Figure 13.17 Example of SCI Operation in Transmission**

- Serial data reception (clocked synchronous mode)

Figure 13.18 shows a sample flowchart for serial reception.

The following procedure should be used for serial data reception.

When changing the operating mode from asynchronous to clocked synchronous, be sure to check that the ORER, PER, and FER flags are all cleared to 0.

The RDRF flag will not be set if the FER or PER flag is set to 1, and neither transmit nor receive operations will be possible.

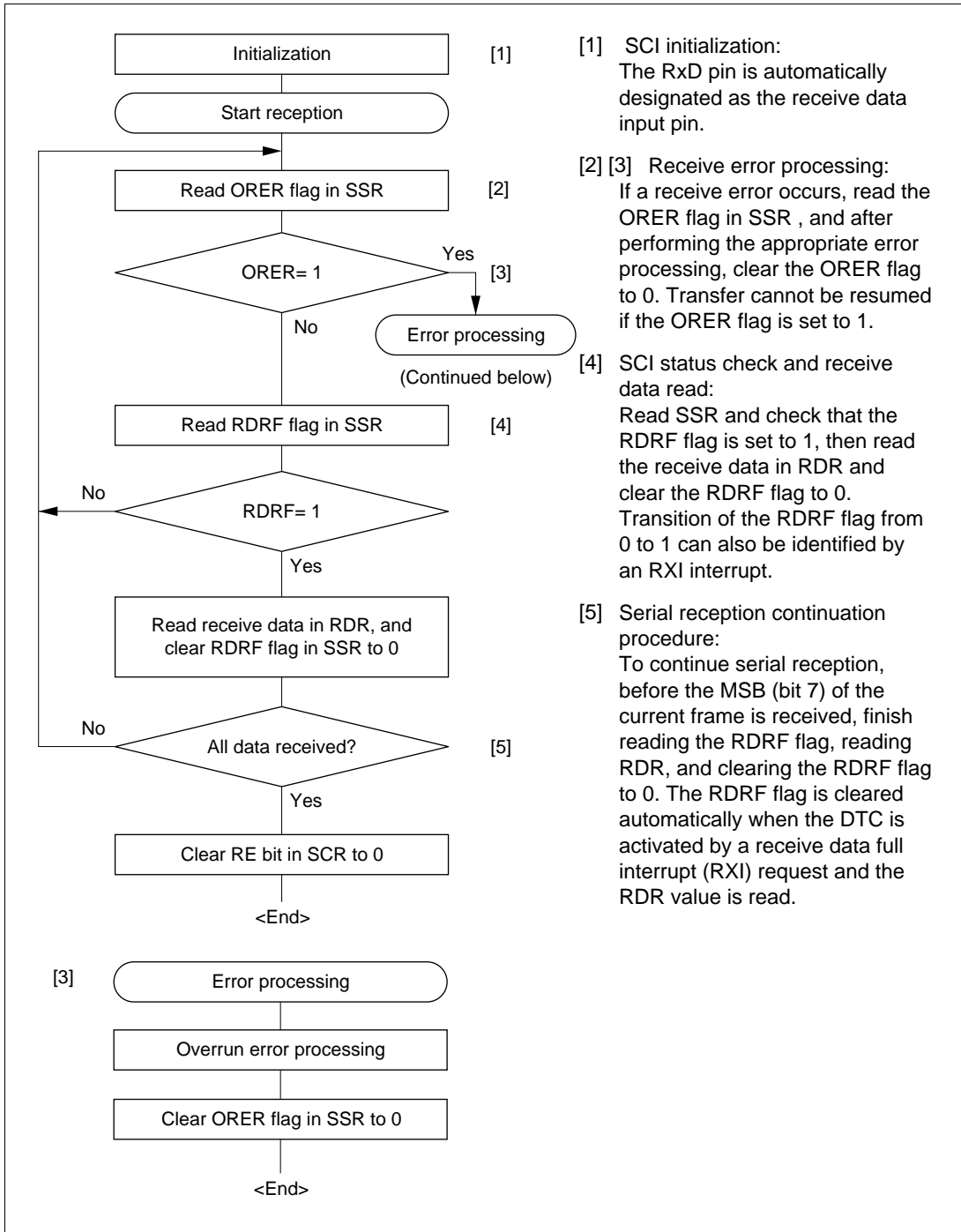


Figure 13.18 Sample Serial Reception Flowchart



In serial reception, the SCI operates as described below.

[1] The SCI performs internal initialization in synchronization with serial clock input or output.

[2] The received data is stored in RSR in LSB-to-MSB order.

After reception, the SCI checks whether the RDRF flag is 0 and the receive data can be transferred from RSR to RDR.

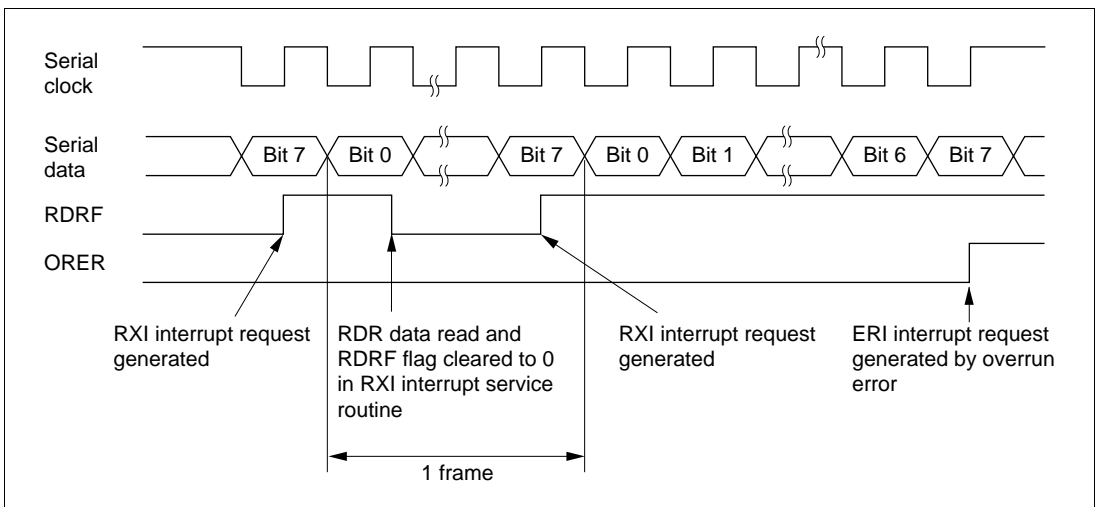
If this check is passed, the RDRF flag is set to 1, and the receive data is stored in RDR. If a receive error is detected in the error check, the operation is as shown in table 13.11.

Neither transmit nor receive operations can be performed subsequently when a receive error has been found in the error check.

[3] If the RIE bit in SCR is set to 1 when the RDRF flag changes to 1, a receive data full interrupt (RXI) request is generated.

Also, if the RIE bit in SCR is set to 1 when the ORER flag changes to 1, a receive error interrupt (ERI) request is generated.

Figure 13.19 shows an example of SCI operation in reception.

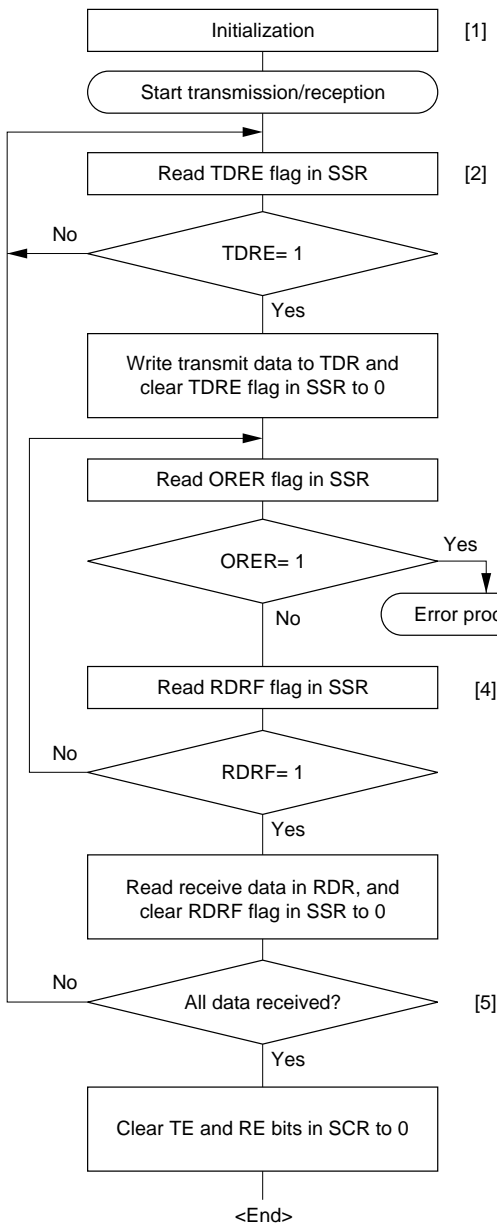


**Figure 13.19 Example of SCI Operation in Reception**

- Simultaneous serial data transmission and reception (clocked synchronous mode)

Figure 13.20 shows a sample flowchart for simultaneous serial transmit and receive operations.

The following procedure should be used for simultaneous serial data transmit and receive operations.



- [1] SCI initialization:  
The TxD pin is designated as the transmit data output pin, and the RxD pin is designated as the receive data input pin, enabling simultaneous transmit and receive operations.
- [2] SCI status check and transmit data write:  
Read SSR and check that the TDRE flag is set to 1, then write transmit data to TDR and clear the TDRE flag to 0. Transition of the TDRE flag from 0 to 1 can also be identified by a TXI interrupt.
- [3] Receive error processing:  
If a receive error occurs, read the ORER flag in SSR, and after performing the appropriate error processing, clear the ORER flag to 0. Transmission/reception cannot be resumed if the ORER flag is set to 1.
- [4] SCI status check and receive data read:  
Read SSR and check that the RDRF flag is set to 1, then read the receive data in RDR and clear the RDRF flag to 0. Transition of the RDRF flag from 0 to 1 can also be identified by an RXI interrupt.
- [5] Serial transmission/reception continuation procedure:  
To continue serial transmission/reception, before the MSB (bit 7) of the current frame is received, finish reading the RDRF flag, reading RDR, and clearing the RDRF flag to 0. Also, before the MSB (bit 7) of the current frame is transmitted, read 1 from the TDRE flag to confirm that writing is possible. Then write data to TDR and clear the TDRE flag to 0. Checking and clearing of the TDRE flag is automatic when the DTC is activated by a transmit data empty interrupt (TXI) request and data is written to TDR. Also, the RDRF flag is cleared automatically when the DTC is activated by a receive data full interrupt (RXI) request and the RDR value is read.

Note: When switching from transmit or receive operation to simultaneous transmit and receive operations, first clear the TE bit and RE bit to 0, then set both these bits to 1 simultaneously.

**Figure 13.20 Sample Flowchart of Simultaneous Serial Transmit and Receive Operations**

## 13.4 SCI Interrupts

The SCI has four interrupt sources: the transmit-end interrupt (TEI) request, receive-error interrupt (ERI) request, receive-data-full interrupt (RXI) request, and transmit-data-empty interrupt (TXI) request. Table 13.12 shows the interrupt sources and their relative priorities. Individual interrupt sources can be enabled or disabled with the TIE, RIE, and TEIE bits in the SCR. Each kind of interrupt request is sent to the interrupt controller independently.

When the TDRE flag in SSR is set to 1, a TXI interrupt request is generated. When the TEND flag in SSR is set to 1, a TEI interrupt request is generated. A TXI interrupt can activate the DTC to perform data transfer. The TDRE flag is cleared to 0 automatically when data transfer is performed by the DTC. The DTC cannot be activated by a TEI interrupt request.

When the RDRF flag in SSR is set to 1, an RXI interrupt request is generated. When the ORER, PER, or FER flag in SSR is set to 1, an ERI interrupt request is generated. An RXI interrupt can activate the DTC to perform data transfer. The RDRF flag is cleared to 0 automatically when data transfer is performed by the DTC. The DTC cannot be activated by an ERI interrupt request.

**Table 13.12 SCI Interrupt Sources**

Channel	Interrupt Source	Description	DTC Activation	Priority*
0	ERI	Interrupt due to receive error (ORER, FER, or PER)	Not possible	High ↑
	RXI	Interrupt due to receive data full state (RDRF)	Possible	
	TXI	Interrupt due to transmit data empty state (TDRE)	Possible	
	TEI	Interrupt due to transmission end (TEND)	Not possible	
1	ERI	Interrupt due to receive error (ORER, FER, or PER)	Not possible	↑
	RXI	Interrupt due to receive data full state (RDRF)	Possible	
	TXI	Interrupt due to transmit data empty state (TDRE)	Possible	
	TEI	Interrupt due to transmission end (TEND)	Not possible	
3	ERI	Interrupt due to receive error (ORER, FER, or PER)	Not possible	↑
	RXI	Interrupt due to receive data full state (RDRF)	Possible	
	TXI	Interrupt due to transmit data empty state (TDRE)	Possible	
	TEI	Interrupt due to transmission end (TEND)	Not possible	

Note: \* This table shows the initial state immediately after a reset. Relative priorities among channels can be changed by means of the interrupt controller.

A TEI interrupt is requested when the TEND flag is set to 1 while the TEIE bit is set to 1. The TEND flag is cleared at the same time as the TDRE flag. Consequently, if a TEI interrupt and a TXI interrupt are requested simultaneously, the TXI interrupt may have priority for acceptance, with the result that the TDRE and TEND flags are cleared. Note that the TEI interrupt will not be accepted in this case.

## 13.5 Usage Notes

The following points should be noted when using the SCI.

### Relation between Writes to TDR and the TDRE Flag

The TDRE flag in SSR is a status flag that indicates that transmit data has been transferred from TDR to TSR. When the SCI transfers data from TDR to TSR, the TDRE flag is set to 1.

Data can be written to TDR regardless of the state of the TDRE flag. However, if new data is written to TDR when the TDRE flag is cleared to 0, the data stored in TDR will be lost since it has not yet been transferred to TSR. It is therefore essential to check that the TDRE flag is set to 1 before writing transmit data to TDR.

### Operation when Multiple Receive Errors Occur Simultaneously

If a number of receive errors occur at the same time, the state of the status flags in SSR is as shown in table 13.13. If there is an overrun error, data is not transferred from RSR to RDR, and the receive data is lost.

**Table 13.13 State of SSR Status Flags and Transfer of Receive Data**

SSR Status Flags				Receive Data Transfer	
RDRF	ORER	FER	PER	RSR to RDR	Receive Error Status
1	1	0	0	X	Overrun error
0	0	1	0	O	Framing error
0	0	0	1	O	Parity error
1	1	1	0	X	Overrun error + framing error
1	1	0	1	X	Overrun error + parity error
0	0	1	1	O	Framing error + parity error
1	1	1	1	X	Overrun error + framing error + parity error

O: Receive data is transferred from RSR to RDR.

X: Receive data is not transferred from RSR to RDR.

**Break Detection and Processing (Asynchronous Mode Only):** When framing error (FER) detection is performed, a break can be detected by reading the RxD pin value directly. In a break, the input from the RxD pin becomes all 0s, and so the FER flag is set, and the parity error flag (PER) may also be set.

Note that, since the SCI continues the receive operation after receiving a break, even if the FER flag is cleared to 0, it will be set to 1 again.

**Sending a Break (Asynchronous Mode Only):** The TxD pin has a dual function as an I/O port whose direction (input or output) is determined by DR and DDR. This can be used to send a break.

Between serial transmission initialization and setting of the TE bit to 1, the mark state is replaced by the value of DR (the pin does not function as the TxD pin until the TE bit is set to 1). Consequently, DDR and DR for the port corresponding to the TxD pin are first set to 1.

To send a break during serial transmission, first clear DR to 0, then clear the TE bit to 0.

When the TE bit is cleared to 0, the transmitter is initialized regardless of the current transmission state, the TxD pin becomes an I/O port, and 0 is output from the TxD pin.

**Receive Error Flags and Transmit Operations (Clocked Synchronous Mode Only):**

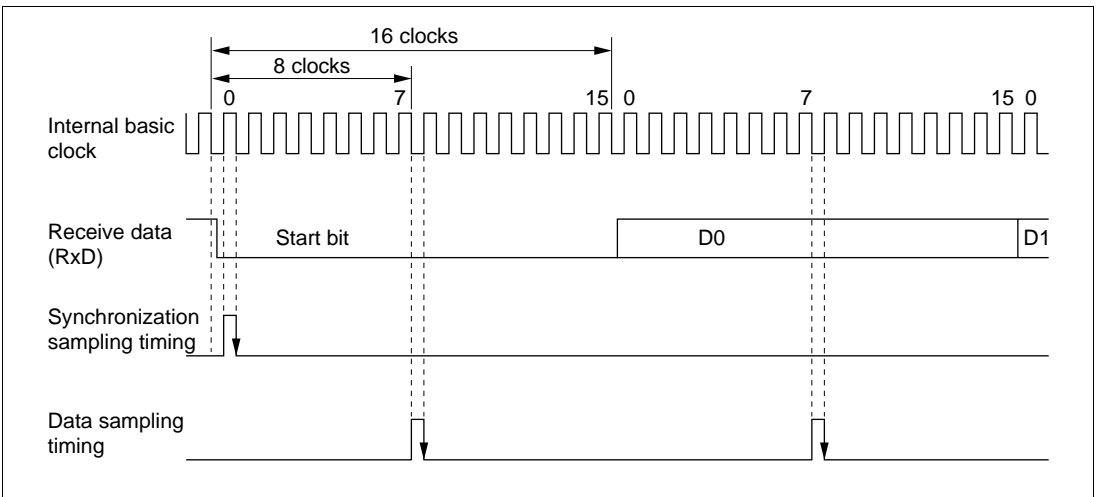
Transmission cannot be started when a receive error flag (ORER, PER, or FER) is set to 1, even if the TDRE flag is cleared to 0. Be sure to clear the receive error flags to 0 before starting transmission.

Note also that receive error flags cannot be cleared to 0 even if the RE bit is cleared to 0.

**Receive Data Sampling Timing and Reception Margin in Asynchronous Mode:**

In asynchronous mode, the SCI operates on a basic clock with a frequency of 16 times the transfer rate.

In reception, the SCI samples the falling edge of the start bit using the basic clock, and performs internal synchronization. Receive data is latched internally at the rising edge of the 8th pulse of the basic clock. This is illustrated in figure 13.21.



**Figure 13.21 Receive Data Sampling Timing in Asynchronous Mode**

Thus the reception margin in asynchronous mode is given by formula (1) below.

$$M = \left| \left( 0.5 - \frac{1}{2N} \right) - (L - 0.5) F - \frac{|D - 0.5|}{N} (1 + F) \right| \times 100\%$$

... Formula (1)

Where M : Reception margin (%)  
N : Ratio of bit rate to clock (N = 16)  
D : Clock duty (D = 0 to 1.0)  
L : Frame length (L = 9 to 12)  
F : Absolute value of clock rate deviation

Assuming values of F = 0 and D = 0.5 in formula (1), a reception margin of 46.875% is given by formula (2) below.

When D = 0.5 and F = 0,

$$M = \left( 0.5 - \frac{1}{2 \times 16} \right) \times 100\%$$

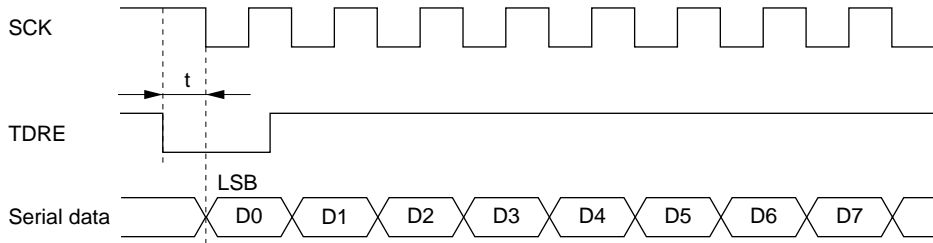
$$= 46.875\%$$

... Formula (2)

However, this is only the computed value, and a margin of 20% to 30% should be allowed in system design.

### Restrictions on Use of DTC

- When an external clock source is used as the serial clock, the transmit clock should not be input until at least 5  $\phi$  clock cycles after TDR is updated by the DTC. Misoperation may occur if the transmit clock is input within 4  $\phi$  clocks after TDR is updated. (Figure 13.22)
- When RDR is read by the DTC, be sure to set the activation source to the relevant SCI reception end interrupt (RXI).



Note: When operating on an external clock, set  $t > 4$  clocks.

**Figure 13.22 Example of Clocked Synchronous Transmission by DTC**

### Operation in Case of Mode Transition

- Transmission

Operation should be stopped (by clearing TE, TIE, and TEIE to 0) before making a module stop mode, software standby mode, watch mode, subactive mode, or subsleep mode transition. TSR, TDR, and SSR are reset. The output pin states in module stop mode, software standby mode, watch mode, subactive mode, or subsleep mode depend on the port settings, and becomes high-level output after the relevant mode is cleared. If a transition is made during transmission, the data being transmitted will be undefined. When transmitting without changing the transmit mode after the relevant mode is cleared, transmission can be started by setting TE to 1 again, and performing the following sequence: SSR read → TDR write → TDRE clearance. To transmit with a different transmit mode after clearing the relevant mode, the procedure must be started again from initialization. Figure 13.23 shows a sample flowchart for mode transition during transmission. Port pin states are shown in figures 13.24 and 13.25. Operation should also be stopped (by clearing TE, TIE, and TEIE to 0) before making a transition from transmission by DTC transfer to module stop mode, software standby mode, watch mode, subactive mode, or subsleep mode transition. To perform transmission with the DTC after the relevant mode is cleared, setting TE and TIE to 1 will set the TXI flag and start DTC transmission.



- Reception

Receive operation should be stopped (by clearing RE to 0) before making a module stop mode, software standby mode, watch mode, subactive mode, or subsleep mode transition. RSR, RDR, and SSR are reset. If a transition is made without stopping operation, the data being received will be invalid.

To continue receiving without changing the reception mode after the relevant mode is cleared, set RE to 1 before starting reception. To receive with a different receive mode, the procedure must be started again from initialization.

Figure 13.26 shows a sample flowchart for mode transition during reception.

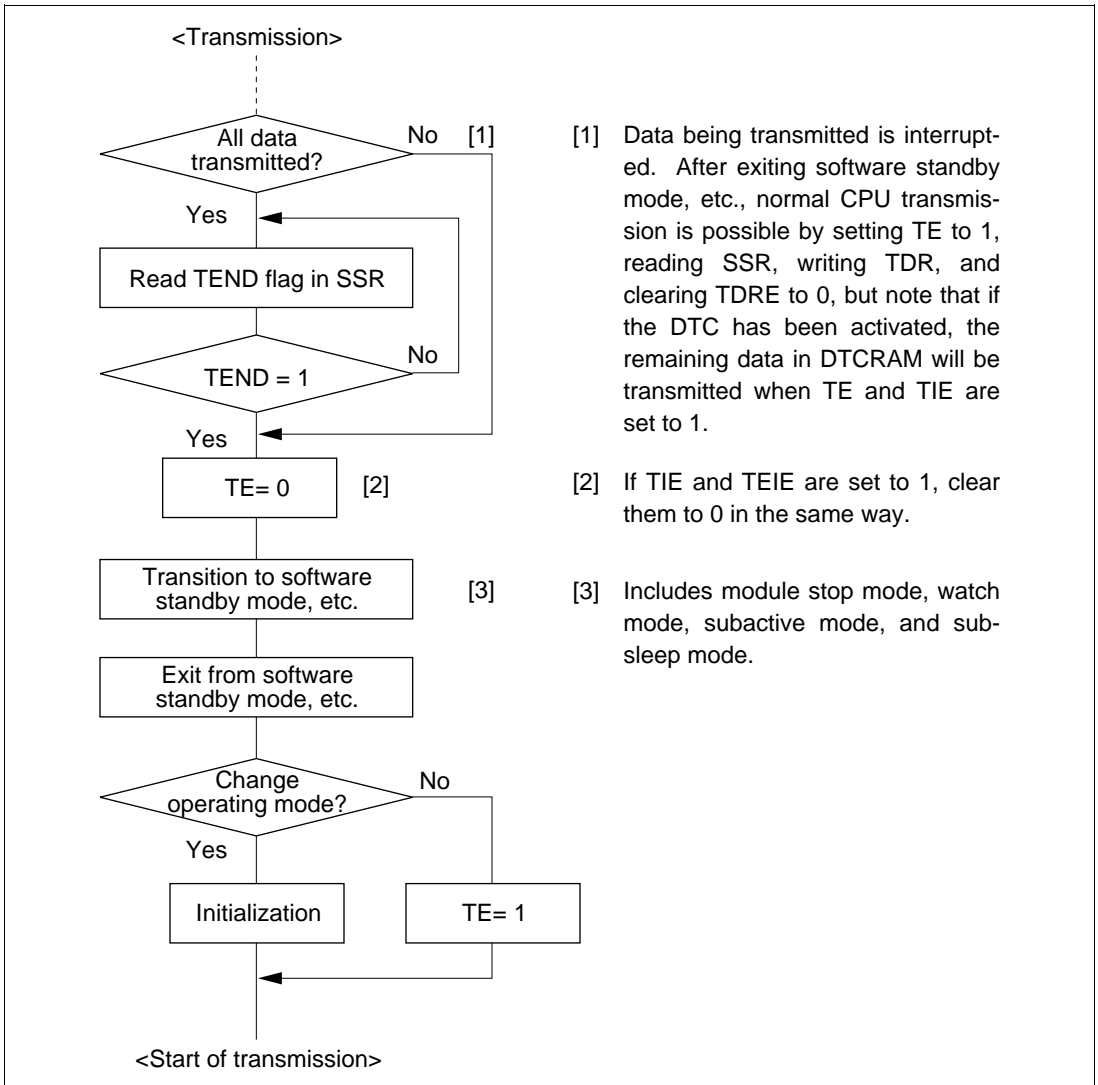
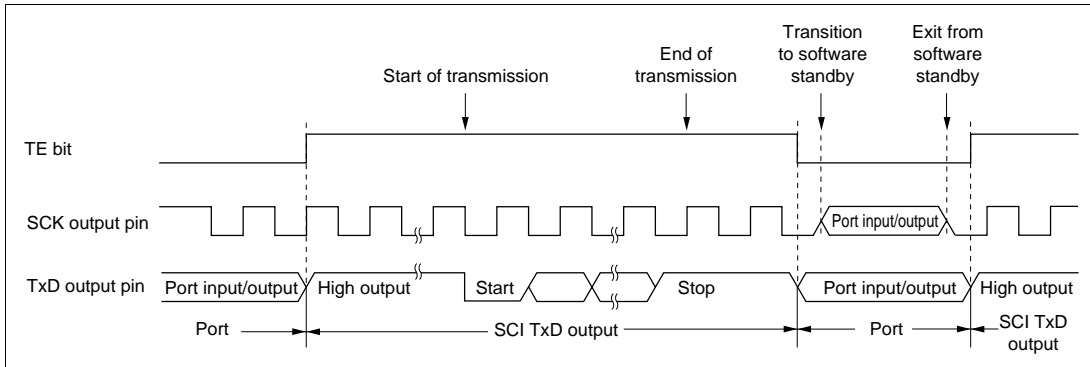
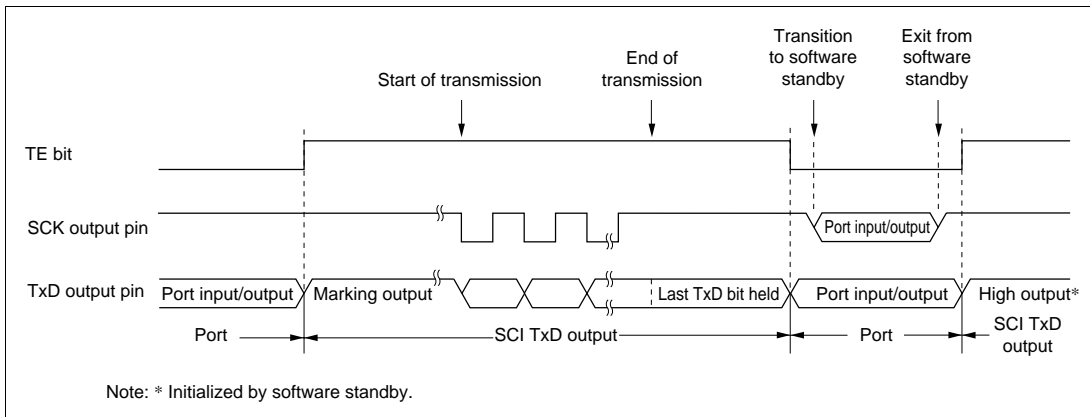


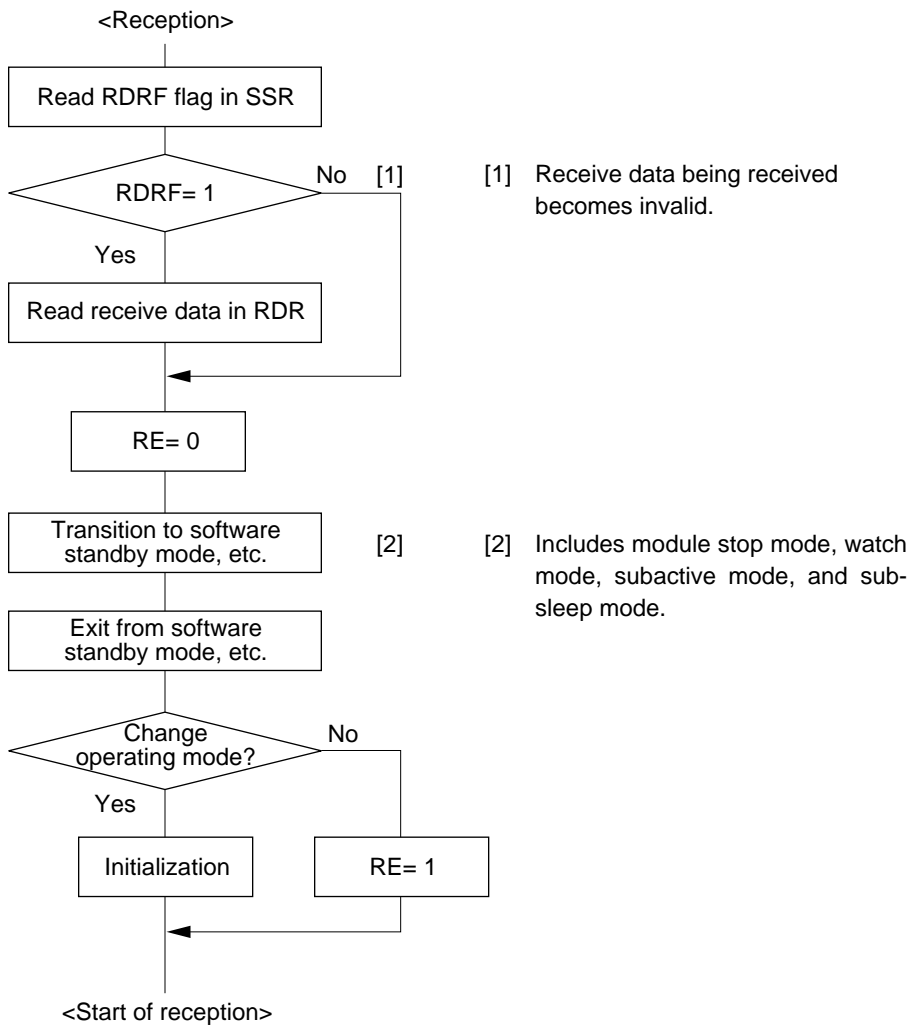
Figure 13.23 Sample Flowchart for Mode Transition during Transmission



**Figure 13.24 Asynchronous Transmission Using Internal Clock**



**Figure 13.25 Synchronous Transmission Using Internal Clock**

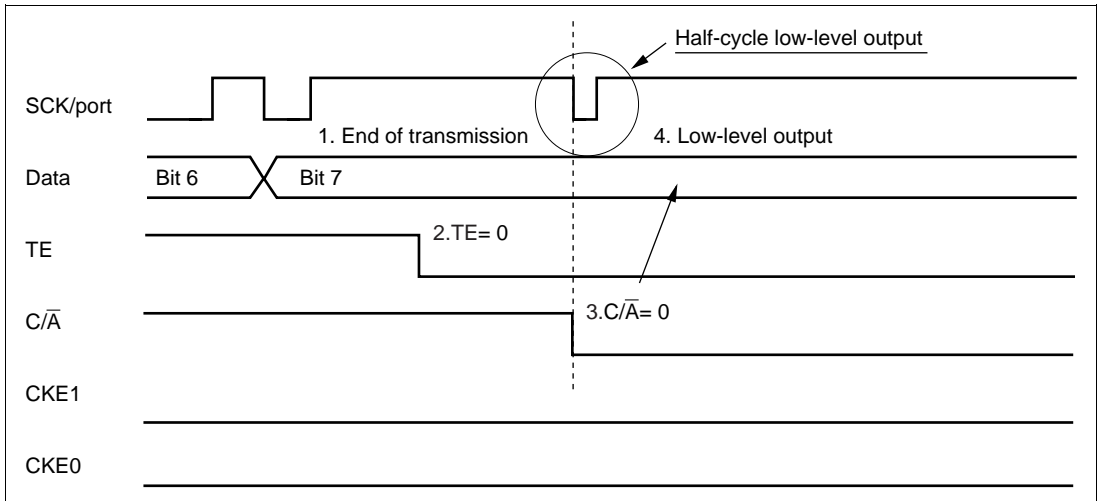


**Figure 13.26 Sample Flowchart for Mode Transition during Reception**

## Switching from SCK Pin Function to Port Pin Function:

- Problem in Operation: When switching the SCK pin function to the output port function (high-level output) by making the following settings while  $DDR = 1$ ,  $DR = 1$ ,  $C/\bar{A} = 1$ ,  $CKE1 = 0$ ,  $CKE0 = 0$ , and  $TE = 1$  (synchronous mode), low-level output occurs for one half-cycle.

1. End of serial data transmission
2.  $TE$  bit = 0
3.  $C/\bar{A}$  bit = 0 ... switchover to port output
4. Occurrence of low-level output (see figure 13.27)

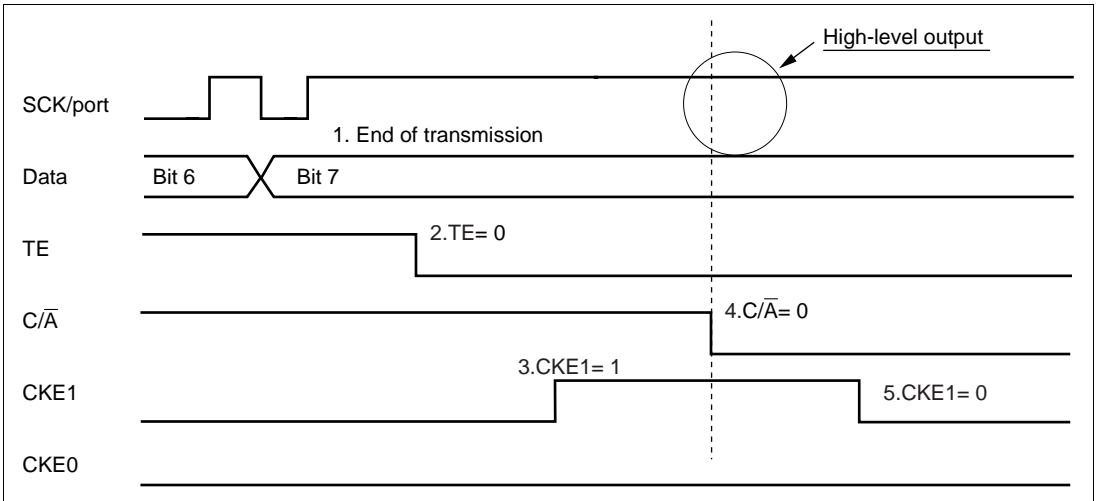


**Figure 13.27 Operation when Switching from SCK Pin Function to Port Pin Function**

- **Sample Procedure for Avoiding Low-Level Output:** As this sample procedure temporarily places the SCK pin in the input state, the SCK/port pin should be pulled up beforehand with an external circuit.

With  $DDR = 1$ ,  $DR = 1$ ,  $C/\bar{A} = 1$ ,  $CKE1 = 0$ ,  $CKE0 = 0$ , and  $TE = 1$ , make the following settings in the order shown.

1. End of serial data transmission
2.  $TE$  bit = 0
3.  **$CKE1$  bit = 1**
4.  $C/\bar{A}$  bit = 0 ... switchover to port output
5.  **$CKE1$  bit = 0**



**Figure 13.28 Operation when Switching from SCK Pin Function to Port Pin Function (Example of Preventing Low-Level Output)**

**SCI3:** SCI3 is dedicated for the FLEX™ decoder II interface, and cannot be connected with LSI-external equipment.

- In SCI3 that is internal FLEX™ decoder II interface, set to 1 the P77DDR and P75DDR bit of P7DDR (Port 7 Data Direction Register) before set the CKE1, CKE0, and TE bit of SCR3.



# Section 14 FLEX™ Roaming Decoder II

**The contents of this section apply to the FLEX™ Roaming Decoder. Note that underlining in the text indicates differences in specification from the FLEX™ Non-Roaming Decoder.**

## 14.1 Overview

Its primary function is to process information received and demodulated from a FLEX radio paging channel, select messages addressed to the paging device and communicate the message information to the host. The FLEX™ decoder II also operates the paging receiver in an efficient power consumption mode and enables the host to operate in a low power mode when monitoring a single channel for message information.

### 14.1.1 Features

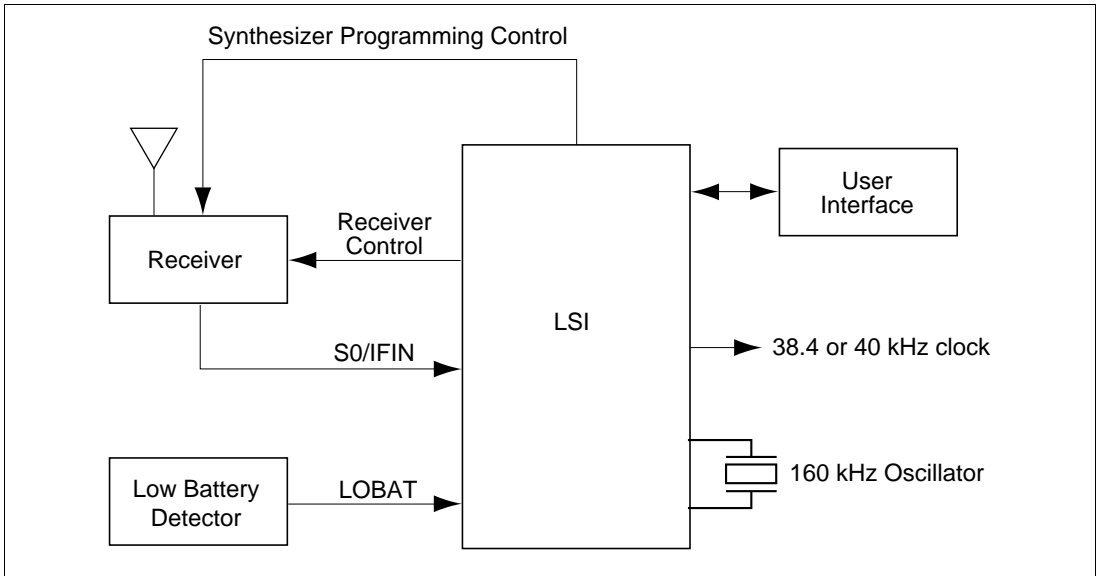
- FLEX™ paging protocol decoder
- 16 programmable user address words
- 16 fixed temporary addresses
- 16 operator messaging addresses
- 1600, 3200, and 6400 bits per second decoding
- Any-phase or single-phase decoding
- Uses standard Serial Peripheral Interface (SPI) in slave mode
- Allows low current STOP mode operation of host processor
- Highly programmable receiver control
- Real time clock time base
- FLEX fragmentation and group messaging support
- Real time clock over-the-air update support
- Compatible with synthesized receivers
- SSID and NID Roaming support
- Low Battery Indication (External detector)
- Backward compatible to the standard and roaming FLEX™ decoders
- Internal demodulator and data slicer
- Improved battery savings via partial correlation and intermittent receiver clock
- Full support for revision 1.9 of the FLEX protocol

**Additional Support:** FLEX System Software from Motorola is a family of software components for building world-class products incorporating messaging capabilities. FLEXstack™ Software is specifically designed to support the FLEX™ Roaming Decoder II IC. FLEXstack Software runs on a product's host processor and takes care of communicating with the FLEX™ decoder II.

acquiring the proper FLEX channel, and fully interpreting the code words that are passed to the host from the FLEX™ decoder II.

**Additional Information:** Additional Information on the FLEX™ protocol decoder chip set and FLEXstack™ software can be found at the following website:  
<http://www.hitachi.co.jp/Sicd/English/Products/micom/stack/stack.html>.

### 14.1.2 System Block Diagram

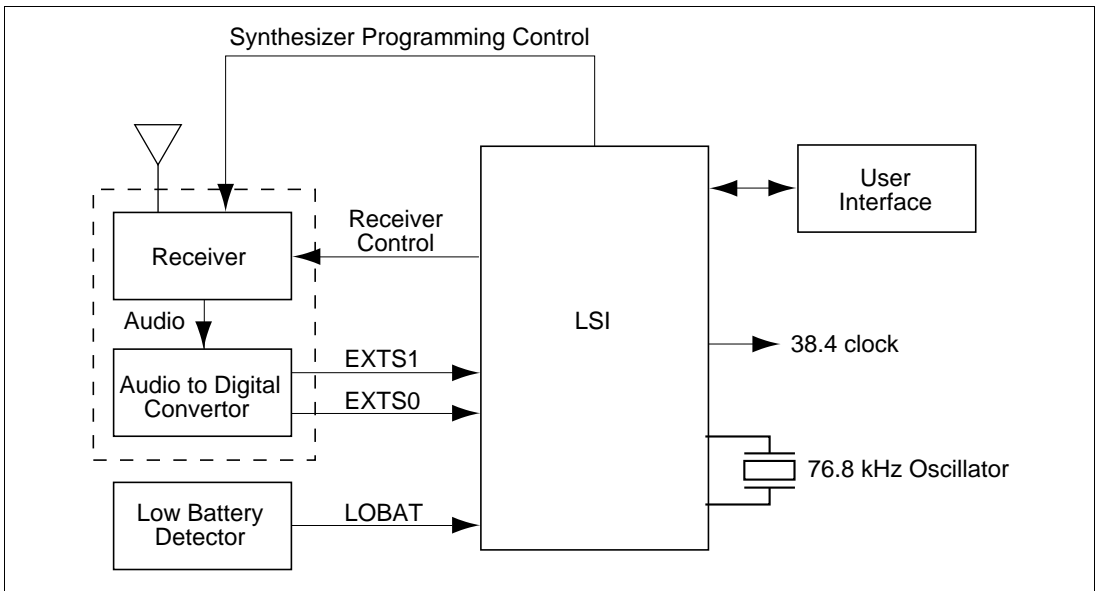


**Figure 14.1 Example Block Diagram Using Internal Demodulator**

When configured to use the internal demodulator, the FLEX™ decoder II connects to a receiver capable of generating a limited (i.e. 1-bit digitized) 455 kHz or 140 kHz IF signal. In this mode, the FLEX™ decoder II has 7 receiver control lines used for warming up and shutting down a receiver in stages. The FLEX™ decoder II has the ability to detect a low battery signal during the receiver control sequences. It interfaces to a host MCU through a standard SPI. It has a 1 minute timer that offers low power support for a time of day function on the host.

When using the internal demodulator, the oscillator frequency (or external clock) must be 160 kHz. The CLKOUT signal can be programmed to be either a 38.4 kHz signal created by fractionally dividing the oscillator clock, or a 40 kHz signal creating by dividing the oscillator clock by 4.





**Figure 14.2 Example Block Diagram Using External Demodulator**

The FLEX™ decoder II can also be configured to connect to a receiver capable of converting a 4 level audio signal into a 2 bit digital signal. In this mode, the FLEX™ decoder II has 8 receiver control lines used for warming up and shutting down a receiver in stages. It also includes configuration settings for the two post detection filter bandwidths required to decode the two symbol rates of the FLEX signal. Also when using an external demodulator, the oscillator (or external clock) must be 76.8 kHz and the CLKOUT signal (when enabled) is 38.4 kHz clock output capable of driving other devices.

### 14.1.3 Functional Block Diagram

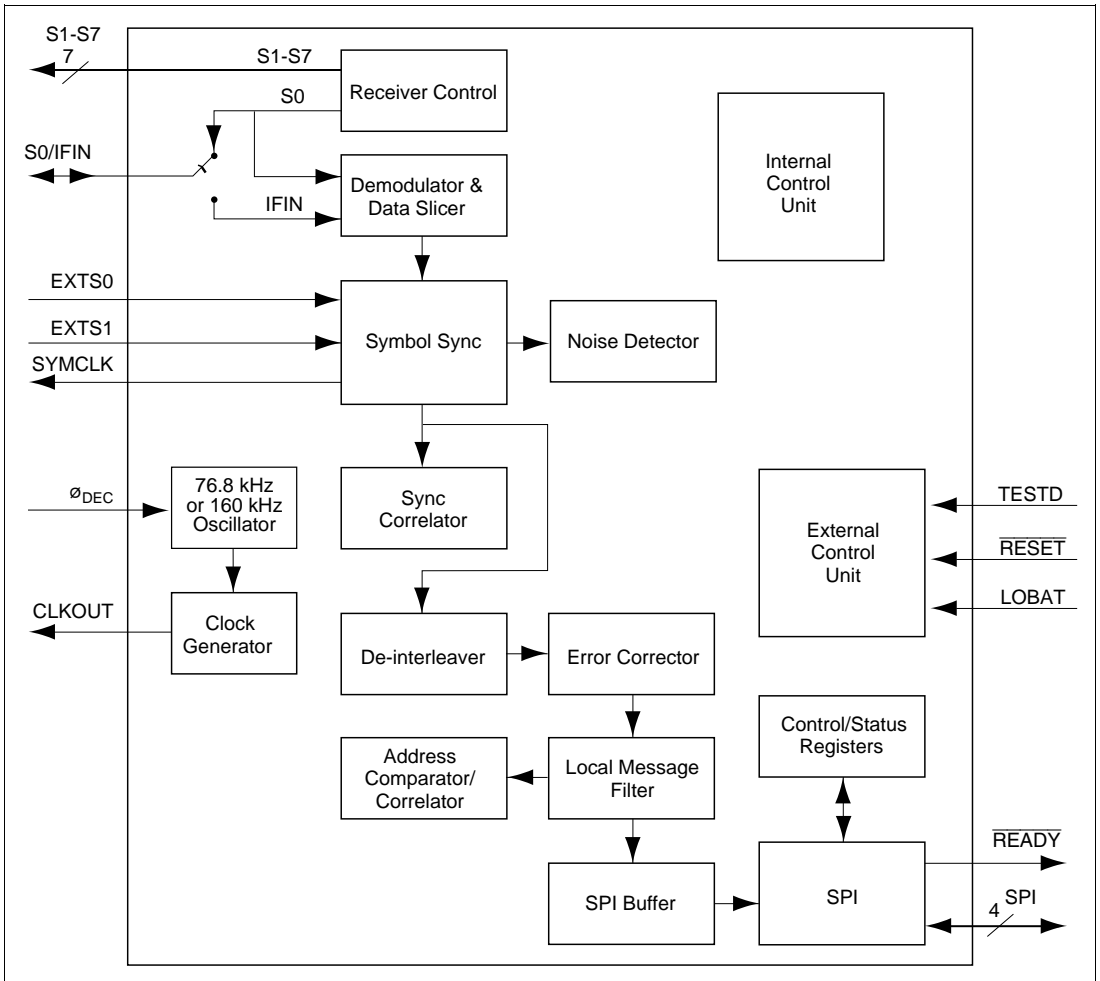


Figure 14.3 Block Diagram

## 14.2 SPI Packets

All data communicated between the FLEX™ decoder II and the host MCU is transmitted on the SPI in 32-bit packets. Each packet consists of an 8-bit ID followed by 24 bits of information. The FLEX™ decoder II uses the SPI bus in full duplex mode. In other words, whenever a packet communication occurs, the data in both directions is valid packet data.

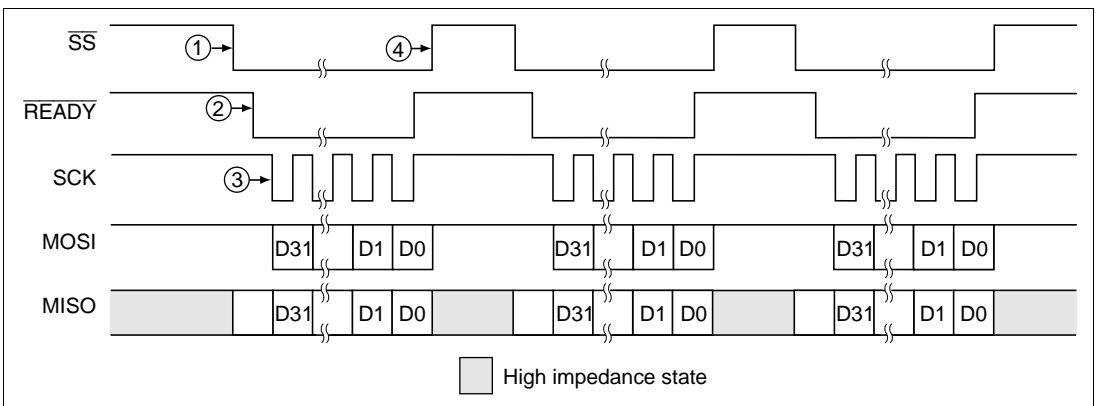
The SPI interface consists of a  $\overline{\text{READY}}$  pin and four SPI pins ( $\overline{\text{SS}}$ , SCK, MOSI, and MISO). The  $\overline{\text{SS}}$  is used as a chip select for the FLEX™ decoder II. The SCK is a clock supplied by the host MCU. The data from the host is transmitted on the MOSI line. The data from the FLEX™ decoder II is transmitted on the MISO line.

Timing requirements for SPI communication are specified in 14.6.1, SPI Timing.

### 14.2.1 Packet Communication Initiated by the Host

Refer to figure 14.4. When the host sends a packet to the FLEX™ decoder II, it performs the following steps:

1. Select the FLEX™ decoder II by driving the  $\overline{\text{SS}}$  pin low.
2. Wait for the FLEX™ decoder II to drive the  $\overline{\text{READY}}$  pin low.
3. Send the 32-bit packet.
4. De-select the FLEX™ decoder II by driving the  $\overline{\text{SS}}$  pin high.
5. Repeat steps 1 through 4 for each additional packet.



**Figure 14.4 Typical Multiple Packet Communications Initiated by the Host**

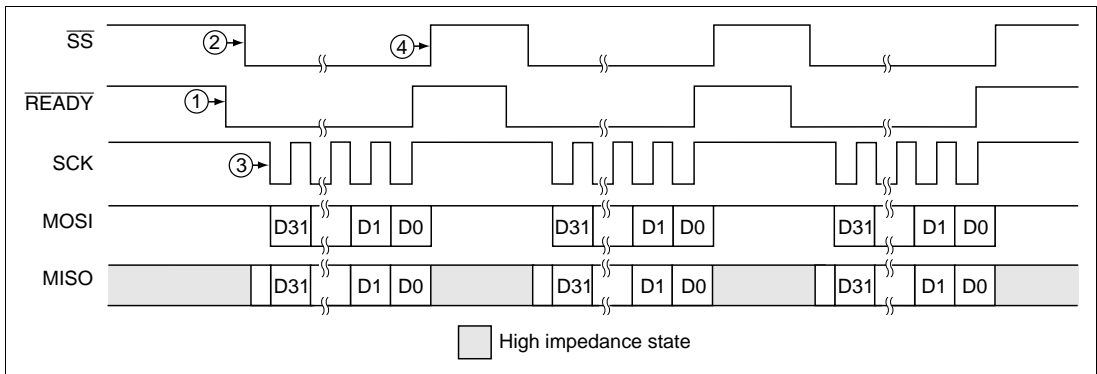
When the host sends a packet, it will also receive a valid packet from the FLEX™ decoder II. If the FLEX™ decoder II is enabled (see 14.3.1, Checksum Packet for a definition of enabled) and has no other packets waiting to be sent, the FLEX™ decoder II will send a status packet.

The host must transition the  $\overline{SS}$  pin from high to low to begin each 32-bit packet. The FLEX™ decoder II must see a negative transition on the  $\overline{SS}$  pin in order for the host to initiate each packet communication.

### 14.2.2 Packet Communication Initiated by the FLEX™ decoder II

Refer to figure 14.5. When the FLEX™ decoder II has a packet for the host to read, the following occurs:

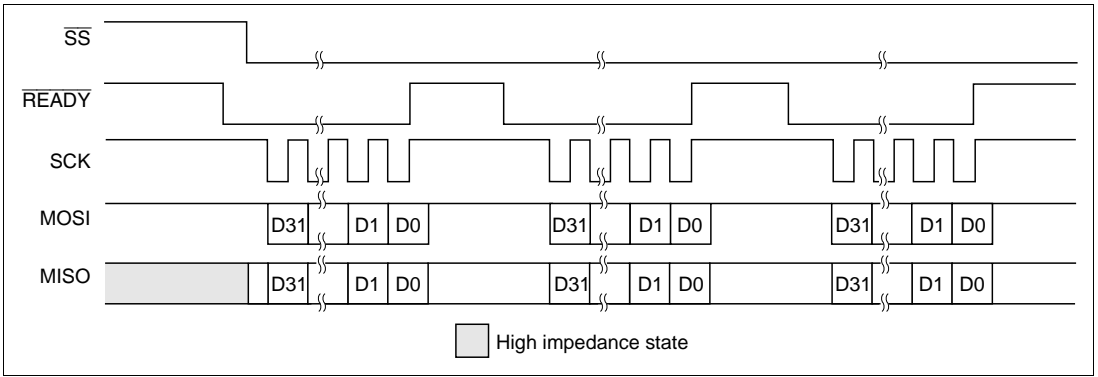
1. The FLEX™ decoder II drives the  $\overline{READY}$  pin low.
2. If the FLEX™ decoder II is not already selected, the host selects the FLEX™ decoder II by driving the  $\overline{SS}$  pin low.
3. The host receives (and sends) a 32-bit packet.
4. The host de-selects the FLEX™ decoder II by driving the  $\overline{SS}$  pin high (optional).



**Figure 14.5 Typical Multiple Packet Communications Initiated by the FLEX™ decoder II**

When the host is reading a packet from the FLEX™ decoder II, it must send a valid packet to the FLEX™ decoder II. If the host has no data to send, it is suggested that the host send a Checksum Packet with all of the data bits set to 0 in order to avoid disabling the FLEX™ decoder II. See 14.3.1, Checksum Packet for more details on enabling and disabling the FLEX™ decoder II.

The following figure illustrates that it is not necessary to de-select the FLEX™ decoder II between packets when the packets are initiated by the FLEX™ decoder II.



**Figure 14.6 Multiple Packet Communications Initiated by the FLEX™ decoder II with No De-select**

### 14.2.3 Host-to-Decoder Packet Map

The upper 8 bits of a packet comprise the packet ID. The following table describes the packet ID's for all of the packets that can be sent to the FLEX™ decoder II from the host.

**Table 14.1 Host-to-Decoder Packet ID Map**

<b>Packet ID (Hexadecimal)</b>	<b>Packet Type</b>
00	Checksum
01	Configuration
02	Control
03	All Frame Mode
04	<u>Operator Message Address Enables</u>
05	<u>Roaming Control Packet</u>
06	<u>Timing Control Packet</u>
07 - 0E	Reserved (Host should never send)
0F	Receiver Line Control
10	Receiver Control Configuration (Off Setting)
11	Receiver Control Configuration (Warm Up 1 Setting)
12	Receiver Control Configuration (Warm Up 2 Setting)
13	Receiver Control Configuration (Warm Up 3 Setting)
14	Receiver Control Configuration (Warm Up 4 Setting)
15	Receiver Control Configuration (Warm Up 5 Setting)
16	Receiver Control Configuration (3200sps Sync Setting)
17	Receiver Control Configuration (1600sps Sync Setting)
18	Receiver Control Configuration (3200sps Data Setting)
19	Receiver Control Configuration (1600sps Data Setting)
1A	Receiver Control Configuration (Shut Down 1 Setting)
1B	Receiver Control Configuration (Shut Down 2 Setting)
1C - 1F	Special (Ignored by FLEX™ decoder II)
20	Frame Assignment (Frames 112 through 127)
21	Frame Assignment (Frames 96 through 111)
22	Frame Assignment (Frames 80 through 95)
23	Frame Assignment (Frames 64 through 79)
24	Frame Assignment (Frames 48 through 63)

<b>Packet ID (Hexadecimal)</b>	<b>Packet Type</b>
25	Frame Assignment (Frames 32 through 47)
26	Frame Assignment (Frames 16 through 31)
27	Frame Assignment (Frames 0 through 15)
28 - 77	Reserved (Host should never send)
78	User Address Enable
79 - 7F	Reserved (Host should never send)
80	User Address Assignment (User address 0)
81	User Address Assignment (User address 1)
82	User Address Assignment (User address 2)
83	User Address Assignment (User address 3)
84	User Address Assignment (User address 4)
85	User Address Assignment (User address 5)
86	User Address Assignment (User address 6)
87	User Address Assignment (User address 7)
88	User Address Assignment (User address 8)
89	User Address Assignment (User address 9)
8A	User Address Assignment (User address 10)
8B	User Address Assignment (User address 11)
8C	User Address Assignment (User address 12)
8D	User Address Assignment (User address 13)
8E	User Address Assignment (User address 14)
8F	User Address Assignment (User address 15)
90 - FF	Reserved (Host should never send)

## 14.2.4 Decoder-to-Host Packet Map

The following table describes the packet ID's for all of the packets that can be sent to the host from the FLEX™ decoder II.

**Table 14.2 Decoder-to-Host Packet ID Map**

Packet ID (Hexadecimal)	Packet Type
00	Block Information Word
01	Address
02 - 57	Vector or Message (ID is word number in frame)
58 - 5F	Reserved
<u>60</u>	<u>Roaming Status Packet</u>
61 - 7D	Reserved
<u>7E</u>	<u>Receiver Shutdown</u>
7F	Status
80 - FE	Reserved
FF	Part ID

## 14.3 Host-to-Decoder Packet Descriptions

The following sections describe the packets of information sent from the host to the FLEX™ decoder II. In all cases the packets should be sent MSB first (bit 7 of byte 3 = bit 31 of the packet = MSB).

### 14.3.1 Checksum Packet

The Checksum Packet is used to insure proper communication between the host and the FLEX™ decoder II. The FLEX™ decoder II exclusive-or's the 24 data bits of every packet it receives (except the Checksum Packet and the special packet ID's 1C through 1F hexadecimal) with an internal checksum register. Upon reset and whenever the host writes a packet to the FLEX™ decoder II, the FLEX™ decoder II is disabled from sending any information to the host processor until the host processor sends a Checksum Packet with the proper checksum value (CV) to the FLEX™ decoder II. When the FLEX™ decoder II is disabled in this way, it prompts the host to read the Part ID Packet. Note that all other operation continues normally when the FLEX™ decoder II is "disabled". Disabled only implies that data cannot be read, all other internal operations continue to function.

When the FLEX™ decoder II is reset, it is disabled and the internal checksum register is initialized to the 24 bit part ID defined in the Part ID Packet. See 14.4.8, Part ID Packet for a



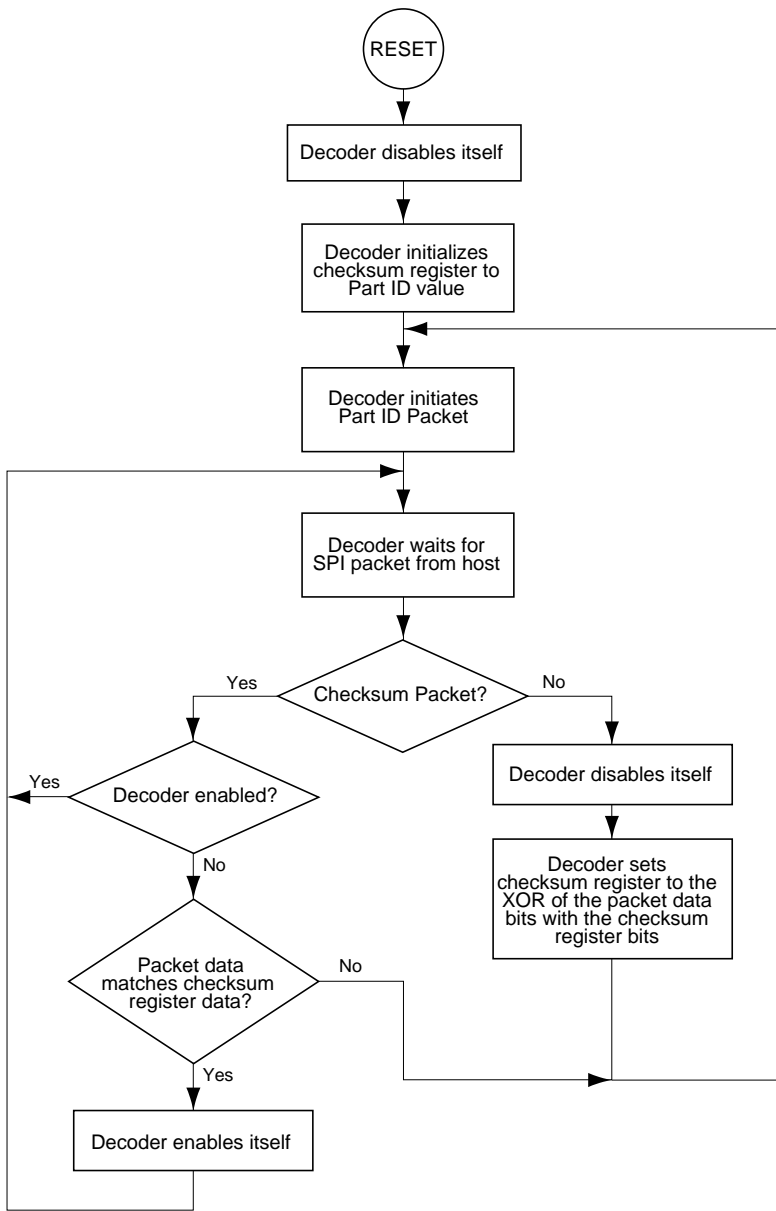
description of the Part ID. Every time a packet other than the Checksum Packet and the special packets 1C through 1F is sent to the decoder IC, the value sent in the 24 information bits is exclusive-or'ed with the internal checksum register, the result is stored back to the checksum register, and the FLEX™ decoder II is disabled. If a Checksum Packet is sent and the CV bits match the bits in the checksum register, the FLEX™ decoder II is enabled. If a Checksum Packet is sent when the FLEX™ decoder II is already enabled, the packet is ignored by the FLEX™ decoder II. If a packet other than the Checksum Packet is sent when the FLEX™ decoder II is enabled, the decoder IC will be disabled until a Checksum Packet is sent with the correct CV bits.

When the host reads a packet out of the FLEX™ decoder II but has no data to send, the Checksum Packet should be sent so the FLEX™ decoder II will not be disabled. The data in the Checksum Packet could be a null packet (32 bit stream of all zeros) since a Checksum Packet will not disable the FLEX™ decoder II. When the host re-configures the FLEX™ decoder II, the FLEX™ decoder II will be disabled from sending any packets other than the Part ID Packet until the FLEX™ decoder II is enabled with a Checksum Packet having the proper data. The ID of the Checksum Packet is 0.

**Table 14.3 Checksum Packet Bit Assignments**

	<b>Bit 7</b>	<b>Bit 6</b>	<b>Bit 5</b>	<b>Bit 4</b>	<b>Bit 3</b>	<b>Bit 2</b>	<b>Bit 1</b>	<b>Bit 0</b>
Byte 3	0	0	0	0	0	0	0	0
Byte 2	CV <sub>23</sub>	CV <sub>22</sub>	CV <sub>21</sub>	CV <sub>20</sub>	CV <sub>19</sub>	CV <sub>18</sub>	CV <sub>17</sub>	CV <sub>16</sub>
Byte 1	CV <sub>15</sub>	CV <sub>14</sub>	CV <sub>13</sub>	CV <sub>12</sub>	CV <sub>11</sub>	CV <sub>10</sub>	CV <sub>9</sub>	CV <sub>8</sub>
Byte 0	CV <sub>7</sub>	CV <sub>6</sub>	CV <sub>5</sub>	CV <sub>4</sub>	CV <sub>3</sub>	CV <sub>2</sub>	CV <sub>1</sub>	CV <sub>0</sub>

CV: Checksum Value.



**Figure 14.7 FLEX™ decoder II Checksum Flow Chart**

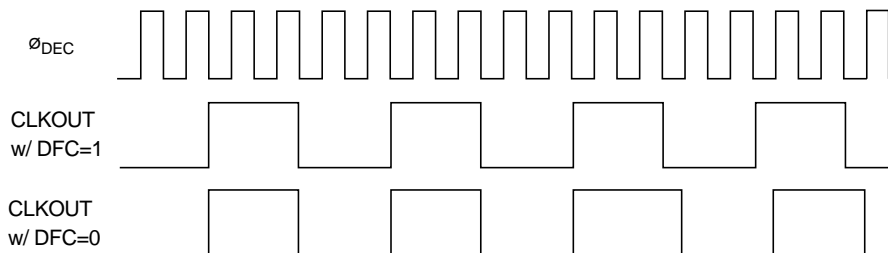
## 14.3.2 Configuration Packet

The Configuration Packet defines a number of different configuration options for the FLEX™ decoder II. Proper operation is not guaranteed if these settings are changed when decoding is enabled (i.e. the ON bit in the Control Packet is set). The ID of the Configuration Packet is 1.

**Table 14.4 Configuration Packet Bit Assignments**

	Bit 7	Bit 6	Bit 5	Bit 4	Bit 3	Bit 2	Bit 1	Bit 0
Byte 3	0	0	0	0	0	0	0	1
Byte 2	0	DFC	0	0	0	IDE	OFD <sub>1</sub>	OFD <sub>0</sub>
Byte 1	0	0	0	0	0	PCE	SP <sub>1</sub>	SP <sub>0</sub>
Byte 0	SME	MOT	COD	MTE	LBP	ICO	0	0

**DFC:** Disable Fractional Clock. When this bit is set and IDE is set, the CLKOUT signal will generate a 40 kHz signal ( $\phi_{DEC}$  divided by 4). When this bit is cleared and IDE is set, the CLKOUT signal will generate 38.4 kHz signal ( $\phi_{DEC}$  fractionally divided by 25/6 see diagram below). This bit has no effect when IDE is cleared. (value after reset=0)



**IDE:** Internal Demodulator Enable. When this bit is set, the internal demodulator is enabled and the clock frequency at  $\phi_{DEC}$  is expected to be 160 kHz. When this bit is cleared, the internal demodulator is disabled and the clock frequency at  $\phi_{DEC}$  is expected to be 76.8 kHz. (value after reset=0)

**OFD:** Oscillator Frequency Difference. These bits describe the maximum difference in the frequency of the 76.8 kHz oscillator crystal with respect to the frequency of the transmitter. These limits should be the worst case difference in frequency due to all conditions including but not limited to aging, temperature, and manufacturing tolerance. Using a smaller frequency difference in this packet will result in lower power consumption due to higher receiver battery save ratios. Note that this value is not the absolute error of the oscillator frequency provided to the FLEX™ decoder II. The absolute error of the clock used by the FLEX transmitter must be taken into account. (e.g. If the transmitter tolerance is +/- 25 ppm and the oscillator tolerance is +/-140 ppm,

the oscillator frequency difference is +/- 165 ppm and OFD should be set to 0.)(value after reset = 0)

OFD <sub>1</sub>	OFD <sub>0</sub>	Frequency Difference
0	0	+/- 300 ppm
0	1	+/- 150 ppm
1	0	+/- 75 ppm
1	1	+/- 0 ppm

**PCE:** Partial Correlation Enable. When this bit is set, partial correlation of addresses is enabled. When partial correlation is enabled, the FLEX™ decoder II will shutdown the receiver before the end of the last FLEX block which contains addresses if it can determine that none of the addresses in that FLEX block will match any enabled address in the FLEX™ decoder II. When this bit is cleared, the receiver will be controlled as it was in previous versions of the FLEX™ decoder II. (value after reset=0)

**SP:** Signal Polarity. These bits set the polarity of EXTS1 and EXTS0 input signals. (value after reset=0) The polarity of the EXTS0 and EXTS1 bits will be determined by the receiver design.

SP <sub>1</sub>	SP <sub>0</sub>	Signal Polarity	
		EXTS1	EXTS0
0	0	Normal	Normal
0	1	Normal	Inverted
1	0	Inverted	Normal
1	1	Inverted	Inverted

FSK Modulation @ SP = 0,0	EXTS1	EXTS0
+ 4800 Hz	1	0
+1600 Hz	1	1
- 1600 Hz	0	1
- 4800 Hz	0	0

**SME:** Synchronous Mode Enable. When this bit is set, a Status Packet will be automatically sent whenever the SMU (synchronous mode update) bit in the Status Packet is set. The host can use the SM (synchronous mode) bit in the Status Packet as an in-range/out-of-range indication. (value after reset=0)

**MOT:** Maximum Off Time. This bit has no effect if AST in the Timing Control Packet is non-zero. When AST=0 and MOT=0, asynchronous A-word searches will time-out in 4 minutes. When

AST=0 and MOT=1, asynchronous A-word searches will time-out in 1 minute. (value after reset=0)

**COD:** Clock Output Disable. When this bit is clear, a 38.4 kHz or 40 kHz (depending on the values of IDE and DFC) signal will be output on the CLKOUT pin. When this bit is set, the CLKOUT pin will be driven low. Note that setting and clearing this bit can cause pulses on the CLKOUT pin that are less than one half the clock period. Also note that when the clock output is enabled and not set for intermittent operation (see ICO in this packet), the CLKOUT pin will always output the clock signal even when the FLEX™ decoder II is in reset (as long as the FLEX™ decoder II oscillator is seeing clocks). Further note that when the FLEX™ decoder II is used in internal demodulator mode (i.e. uses a 160 kHz oscillator), the CLKOUT pin will be 80 kHz from reset until the time the IDE bit is set. This is because the FLEX™ decoder II defaults to external demodulator mode at reset. (value after reset=0)

**MTE:** Minute Timer Enable. When this bit is set, a Status Packet will be sent at one minute intervals with the MT (minute time-out) bit in the Status Packet set. When this bit is clear, the internal one-minute timer stops counting. The internal one-minute timer is reset when this bit is changed from 0 to 1 or when the MTC (minute timer clear) bit in the Control Packet is set. Note that the minute timer will not be accurate using a 160 kHz oscillator until the IDE bit is set. (value after reset=0)

**LBP:** Low Battery Polarity. This bit defines the polarity of the FLEX™ decoder's LOBAT pin. The LB bit in the Status Packet is initialized to the inverse value of this bit when the FLEX™ decoder II is turned on (by setting the ON bit in the Control Packet). When the FLEX™ decoder II is turned on, the first low battery update in the Status Packet will be sent to the host when a low battery condition is detected on the LOBAT pin. Setting this bit means that a high on the LOBAT pin indicates a low voltage condition. (value after reset=0)

**ICO:** Intermittent Clock Out. When this bit is clear and COD is clear, a 38.4 kHz or 40 kHz (depending on the values of IDE and DFC) signal will be output on the CLKOUT pin. When this bit is set and COD is clear, the clock will only be output on the CLKOUT pin while the receiver is not in the Off state. The clock will be output for a few cycles before the receiver transitions from the off state and for a few cycles after the receiver transitions to the off state (this is to insure that the receiver receives enough clocks to detect and process the changes to and from the Off state). The CLKOUT pin will be driven low when it is not driving a clock. Note that when the clock is automatically enabled and disabled (i.e. when ICO is set), the CLKOUT signal transitions will be clean (i.e. no pulses less than half the clock period) when it transitions between no clock and clocked output. This bit has no effect when COD is set. (value after reset=0)

### 14.3.3 Control Packet

The Control Packet defines a number of different control bits for the FLEX™ decoder II. The ID of the Control Packet is 2.

**Table 14.5 Control Packet Bit Assignments**

	Bit 7	Bit 6	Bit 5	Bit 4	Bit 3	Bit 2	Bit 1	Bit 0
Byte 3	0	0	0	0	0	0	1	0
Byte 2	FF <sub>7</sub>	FF <sub>6</sub>	FF <sub>5</sub>	FF <sub>4</sub>	FF <sub>3</sub>	FF <sub>2</sub>	FF <sub>1</sub>	FF <sub>0</sub>
Byte 1	0	SPM	PS <sub>1</sub>	PS <sub>0</sub>	0	0	0	0
Byte 0	0	SBI	0	MTC	0	0	EAE	ON

**FF:** Force Frame 0-7. These bits enable and disable forcing the FLEX™ decoder II to look in frames 0 through 7. When an FF bit is set, the FLEX™ decoder II will decode the corresponding frame. Unlike the AF bits in the Frame Assignment Packets, the system collapse of a FLEX system will not affect frames assigned using the FF bits (e.g. Where as setting AF<sub>0</sub> to 1 when the system collapse is 5 will cause the decoder to decode frames 0, 32, 64, and 96, setting FF<sub>0</sub> to 1 when the system collapse is 5 will only cause the decoder to decode frame 0.). This may be useful for acquiring transmitted time information or channel attributes (e.g. Local ID). (value after reset=0)

**SPM:** Single Phase Mode. When this bit is set, the FLEX™ decoder II will decode only one phase of the transmitted data. When this bit is clear, the FLEX™ decoder II will decode all of the phases it receives. A change to this bit while the FLEX™ decoder II is on, will not take affect until the next block 0 of the next decoded frame. (value after reset=0)

**PS:** Phase Select. When the SPM bit is set, these bits define what phase the FLEX™ decoder II should decode according to the following table. This value is determined by the service provider. A change to these bits while the FLEX™ decoder II is on, will not take affect until the next block 0 of a frame. (value after reset=0)

PS Value		Phase Decoded (based on FLEX Data Rate)		
PS <sub>1</sub>	PS <sub>0</sub>	1600bps	3200bps	6400bps
0	0	a	a	a
0	1	a	a	b
1	0	a	c	c
1	1	a	c	d

**SBI:** Send Block Information words 2-4. When this bit is set, any errored or time related block information words 2-4 will be sent to the host. See 14.4.1, Block Information Word Packet for a description of the words sent. (value after reset=0)

**MTC:** Minute Timer Clear. Setting this bit will cause the one minute timer to restart from 0.

**EAE:** End of Addresses Enable. When this bit is set, the EA bit in the Status Packet will be set immediately after the FLEX™ decoder II decodes the last address word in the frame if any of the enabled FLEX™ decoder II addresses was detected in the frame. When this bit is cleared, the EA bit will never be set.

**ON:** Turn On Decoder. Set if the FLEX™ decoder II should be decoding FLEX signals. Clear if signal processing should be off (very low power mode). If the ON bit is changed twice and the control packets making the changes are received within 2ms of each other, the FLEX™ decoder II may ignore the double change and stay in its original state (e.g. if it is turned off then on again within 2ms it may stay on and ignore the off pulse). Therefore it is recommended that the host insures a minimum of 2ms between changes in the ON bit. (value after reset=0)

Note: Turning off the FLEX™ decoder II must be done using the following sequence. This sequence is performed automatically by the FLEXstack software version 1.2 and greater.

1. Turn off the FLEX™ decoder II by sending a Control Packer with the ON bit cleared.
2. Turn on the FLEX™ decoder II by sending a Control Packer with the ON bit set.
3. Turn off the FLEX™ decoder II by sending a Control Packer with the ON bit cleared.

Timing between these steps is specified below and is measured from the positive edge of the last clock of one packet to the positive edge of the last clock of the next packet:

- The minimum time between steps 1 and 2 is 2ms or the programmed shut down time, whichever is greater. The programmed shut down time is the sum of all the of the times programmed in the used Receiver Shut Down Settings Packets.
- There is no maximum time between steps 1 and 2.
- The minimum time between steps 2 and 3 is 2ms.
- The maximum time between steps 2 and 3 is the programmed warm up time minus 2ms. The programmed warm up time is the sum of all the of the times programmed in the used Receiver Warm Up Settings Packets.

#### 14.3.4 All Frame Mode Packet

The All Frame Mode Packet is used to decrement temporary address enable counters by one, decrement the all frame mode counter by one, and/or enable or disable forcing all frame mode. All frame mode is enabled if any temporary address enable counter is non-zero, the all frame mode counter is non-zero, or the force all frame mode bit is set. If all frame mode is enabled, the FLEX™ decoder II will attempt to decode every frame and send a Status Packet with the EOF (end-of-frame) bit set at the end of every frame. Both the all frame mode counter and the

temporary address enable counters can only be incremented internally by the FLEX™ decoder II and can only be decremented by the host. The FLEX™ decoder II will increment a temporary address enable counter whenever a short instruction vector is received assigning the corresponding temporary address. See 14.5.4, Operation of a Temporary Address for details. The FLEX™ decoder II will increment the all frame mode counter whenever an alphanumeric, HEX / binary, or secure vector is received. When the host determines that a message associated with a temporary address, or a fragmented message has ended, then the appropriate temporary address counter or all frame mode counter should be decremented by writing an All Frame Mode Packet to the FLEX™ decoder II in order to exit the all frame mode, thereby improving battery life. See 14.5.3, Building a Fragmented Message for details. Neither the temporary address enable counters nor the all frame mode counter can be incremented past the value 127 (i.e. it will not roll-over) or decremented past the value 0. The temporary address enable counters and the all frame mode counter are initialized to 0 at reset and when the decoder is turned off. The ID of the All Frame Mode Packet is 3.

**Table 14.6 All Frame Mode Packet Bit Assignments**

	Bit 7	Bit 6	Bit 5	Bit 4	Bit 3	Bit 2	Bit 1	Bit 0
Byte 3	0	0	0	0	0	0	1	1
Byte 2	DAF	FAF	0	0	0	0	0	0
Byte 1	DTA <sub>15</sub>	DTA <sub>14</sub>	DTA <sub>13</sub>	DTA <sub>12</sub>	DTA <sub>11</sub>	DTA <sub>10</sub>	DTA <sub>9</sub>	DTA <sub>8</sub>
Byte 0	DTA <sub>7</sub>	DTA <sub>6</sub>	DTA <sub>5</sub>	DTA <sub>4</sub>	DTA <sub>3</sub>	DTA <sub>2</sub>	DTA <sub>1</sub>	DTA <sub>0</sub>

**DAF:** Decrement All Frame counter. Setting this bit decrements the all frame mode counter by one. If a packet is sent with this bit clear, the all frame mode counter is not affected. (value after reset =0)

**FAF:** Force All Frame mode. Setting this bit forces the FLEX™ decoder II to enter all frame mode. If this bit is clear, the FLEX™ decoder II may or may not be in all frame mode depending on the status of the all frame mode counter and the temporary address enable counters. This may be useful in acquiring transmitted time information. (value after reset=0)

**DTA:** Decrement Temporary Address enable counter. When a bit in this word is set, the corresponding temporary address enable counter is decremented by one. When a bit is cleared, the corresponding temporary address enable counter is not affected. When a temporary address enable counter reaches zero, the temporary address is disabled.(value after reset=0)



### 14.3.5 Operator Messaging Address Enable Packet

The contents of this section apply to the FLEX Roaming Decoder. They are not applicable to the FLEX Non-Roaming Decoder.

The operator messaging address enable packet is used to enable and disable the built-in FLEX operator messaging addresses. Enabling and disabling operator messaging addresses does not affect what frames the decoder IC decodes. To decode the proper frames, the host must modify the FF bits in the Control Packet or the AF bits in the Frame Assignment Packets. The ID of the operator messaging address enable packet is 4.

**Table 14.7 System Address Enable Packet Bit Assignments**

	Bit 7	Bit 6	Bit 5	Bit 4	Bit 3	Bit 2	Bit 1	Bit 0
Byte 3	0	0	0	0	0	1	0	0
Byte 2	0	0	0	0	0	0	0	0
Byte 1	OAE <sub>15</sub>	OAE <sub>14</sub>	OAE <sub>13</sub>	OAE <sub>12</sub>	OAE <sub>11</sub>	OAE <sub>10</sub>	OAE <sub>9</sub>	OAE <sub>8</sub>
Byte 0	OAE <sub>7</sub>	OAE <sub>6</sub>	OAE <sub>5</sub>	OAE <sub>4</sub>	OAE <sub>3</sub>	OAE <sub>2</sub>	OAE <sub>1</sub>	OAE <sub>0</sub>

**OAE:** Operator messaging Address Enable. When a bit is set, the corresponding operator messaging address is enabled. When it is cleared, the corresponding operator messaging address is disabled. OAE<sub>0</sub> through OAE<sub>15</sub> corresponds to the hexadecimal operator messaging address values of 1F7810 through 1F781F respectively. (value after reset=0)

### 14.3.6 Roaming Control Packet

The contents of this section apply to the FLEX Roaming Decoder. They are not applicable to the FLEX Non-Roaming Decoder.

The roaming control packet controls the features of the FLEX™ decoder II that allow implementation of a roaming device. The ID of the roaming control packet is 5.

**Table 14.8 Roaming Control Packet Bit Assignments**

	Bit 7	Bit 6	Bit 5	Bit 4	Bit 3	Bit 2	Bit 1	Bit 0
Byte 3	0	0	0	0	0	1	0	1
Byte 2	IRS	NBC	MCM	IS1	SDF	RSP	SND	CND
Byte 1	RND	ABI	SAS	DAS	0	0	0	0
Byte 0	0	0	MFC <sub>1</sub>	MFC <sub>0</sub>	0	0	MCO <sub>1</sub>	MCO <sub>0</sub>

**IRS:** Ignore Re-synchronization Signal. When this bit is set, the FLEX™ decoder II will not go asynchronous when detecting an Ar or Ar signal during searches for A-words. It will merely report that the re-synchronization signal was received by setting RSR to 1 in the Roaming Status packet. This allows the host to decide what to do when the paging device is synchronous to more than one channel and only one channel is sending the re-synchronization signal. It also prevents the FLEX™ decoder II from losing synchronization when it detects the re-synchronization signal while the paging device is checking an unknown channel. This bit is set and cleared by the host. (value after reset=0)

**NBC:** Network Bit Check. Setting this bit will enable reporting of the received network bit value (NBU and n) in the Roaming Status Packet. Setting this bit also makes the FLEX™ decoder II abandon a frame after the Frame Info word without synchronizing to the frame if the frame information word is uncorrectable or if the n bit in the frame information word is not set. If the FLEX™ decoder II was in synchronous mode when this occurred (probably due to synchronizing to a second channel), it will maintain synchronization to the original channel. If the FLEX™ decoder II was in asynchronous mode when this occurred, it will stay in asynchronous mode and end the A-word search. This is done to avoid synchronizing to a non-roaming channel when searching for roaming channels. This bit is set and cleared by the host. (value after reset=0)

**MCM:** Manual Collapse Mode. When this bit is set, the FLEX™ decoder II behaves as if the system collapse was 7. The FLEX™ decoder II will not apply the received system collapse to the AF bits. When this bit is set, the received system collapse is reported to the host via SCU and RSC in the Roaming Status Packet. This is so the host can modify the AF bits based on the system collapse of the channel. This bit is set and cleared by the host. (value after reset=0)

**IS1:** Invert EXTS1. Setting this bit inverts the expected polarity of the EXTS1 pin from the way it is configured by SP 1 in the Configuration Packet (e.g. if both IS1 and SP 1 are set, the polarity of the EXTS1 pin is untouched). This bit is intended to be changed when a change in a channel changes the polarity of the received signal. This bit is set and cleared by the host. This bit has the equivalent effect when using the internal demodulator. (value after reset=0)

**SDF:** Stop Decoding Frame. Setting this bit causes the FLEX™ decoder II to stop decoding a frame without losing frame synchronization. This bit is set by the host, and cleared by the FLEX™ decoder II once it has been processed. The packet with the SDF bit set must be sent after receiving the status packet with EA bit set. It must be sent within 40ms of the end of block in which the FLEX™ decoder II set the EA bit. (value after reset=0)

**RSP:** Receiver Shutdown Packet enable. When this bit is set, a Receiver Shutdown Packet will be sent whenever the receiver is shut down. The receiver shutdown packet informs the host that the receiver shutdown, and how long it will be before the FLEX™ decoder II will automatically warm the receiver back up. (value after reset=0)

**SND:** Start Noise Detect. Setting this bit while the FLEX™ decoder II is battery saving will cause it to warm-up the receiver, run a noise detect, and report the result of the noise detect via NDR in

the Roaming Status Packet. This bit is set by the host, and cleared by the FLEX™ decoder II once it has been processed. If the time comes for the FLEX™ decoder II to warm up automatically or the SAS bit is set while an SND is being processed, the noise detect will be abandoned and the abandoned noise detect result (NDR = 01) will be sent in the Roaming Status Packet. (value after reset=0)

**CND:** Continuous Noise Detect. Setting this bit will cause the FLEX™ decoder II to do continuous noise detects during the decoded block data of a frame. The results of the noise detect will only be reported if noise is detected (NDR = 11). Only one noise detected result (NDR=11) will be sent per block. If the FLEX™ decoder II has not completed a noise detect when it shuts down for the frame, that noise detect will be abandoned, but no abandon result (NDR=01) will be sent. This bit is set and cleared by the host. (value after reset=0)

**RND:** Report Noise Detects. Setting this bit will cause the FLEX™ decoder II to report the results of the noise detects it does under normal asynchronous operation (when first turned on and when asynchronous). The results of the noise detect will be reported via NDR in the Roaming Status Packet. This bit is set and cleared by the host. (value after reset=0)

**ABI:** All Block Information words. When this bit is set, the FLEX™ decoder II will send all received Block Information words 2-4 to the host. Note: Setting the SBI bit in the Control Packet only enables errored and real time clock related block info words. (value after reset=0)

**SAS:** Start A-word Search. Setting this bit while in asynchronous battery save mode will cause the FLEX™ decoder II to warm-up the receiver and run an A-word search. If, during the A-word search, the FLEX™ decoder II finds sufficient FLEX signal, it will enter synchronous mode and start decoding the frame. If the A-word search times-out without finding sufficient FLEX signal, it will battery save and continue doing periodic noise detects. The time-out for the A-word searches is controlled by the AST bits in the Timing Control Packet and the MOT bit in the Configuration Packet. The A-word search takes priority over noise detects. Therefore, if the FLEX™ decoder II is performing an A-word search and the time comes to do automatic noise detect, the noise detect will not be performed. This bit is set by the host, and cleared by the FLEX™ decoder II once it has been acted on. (value after reset=0)

**DAS:** Disable A-word Search. When this bit is set, an A-word search will not automatically occur after a noise detect in asynchronous mode finds FLEX signal. This includes automatic noise detects and noise detects initiated by the host by setting SND. The FLEX™ decoder II will shut down the receiver after the noise detect completes regardless of the result. When this bit is cleared, A-word searches will occur after a noise detect finds signal in asynchronous mode. (value after reset=0)

**MFC:** Missed Frame Control. These bits control the frames for which missing frame data (MS1, MFI, MS2, MBI, and MAW) is reported in the Roaming Status Packet. (value after reset=0)

MFC <sub>1</sub>	MFC <sub>0</sub>	Missing Frame Data Reported
0	0	Never
0	1	Only during frames 0 through 3
1	0	Only during frames 0 through 7
1	1	Always

**MCO:** Maximum Carry On. The value of these bits sets the maximum carry on that the FLEX™ decoder II will follow. For example, if the FLEX™ decoder II receives a carry on of 3 over the air and MCO is set to 1, the FLEX™ decoder II will only carry on for one frame. (value after reset=3)

### 14.3.7 Timing Control Packet

The contents of this section apply to the FLEX Roaming Decoder. They are not applicable to the FLEX Non-Roaming Decoder.

The timing control packet gives the host control of the timing used when the FLEX™ decoder II is in asynchronous mode. The packet ID for the timing control packet is 6.

**Table 14.9 Timing Control Packet Bit Assignments**

	Bit 7	Bit 6	Bit 5	Bit 4	Bit 3	Bit 2	Bit 1	Bit 0
Byte 3	0	0	0	0	1	1	1	1
Byte 2	0	0	0	0	0	0	0	0
Byte 1	AST <sub>7</sub>	AST <sub>6</sub>	AST <sub>5</sub>	AST <sub>4</sub>	AST <sub>3</sub>	AST <sub>2</sub>	AST <sub>1</sub>	AST <sub>0</sub>
Byte 0	ABT <sub>7</sub>	ABT <sub>6</sub>	ABT <sub>5</sub>	ABT <sub>4</sub>	ABT <sub>3</sub>	ABT <sub>2</sub>	ABT <sub>1</sub>	ABT <sub>0</sub>

**AST:** A-word Search Time. The value of these bits sets the A-word search time for all asynchronous A-word searches in units of 80ms (e.g. value of 1 is 80ms, value of 2 is 160ms, etc.) If the value is 0, the FLEX™ decoder II defaults to the 1-minute (MOT=1) or 4-minute (MOT=0) A-word search time controlled by the MOT bit in the configuration packet. (Value after reset=0)

**ABT:** Asynchronous Battery-save Time. The value of these bits sets the battery save time (time from the beginning of one automatic noise detect to the beginning of the next automatic noise detect) in asynchronous mode in units of 80ms (e.g. value of 1 is 80ms, value of 2 is 160ms, etc.) If the value is 0, the battery save time is set to the default value of 1.5 seconds. The minimum allowed ABT is 320ms, therefore values of 1, 2, 3, and 4 are invalid. (Value after reset=0)

### 14.3.8 Receiver Line Control Packet

This packet gives the host control over the settings on the receiver control lines (S0-S7) in all modes except reset. In reset, the receiver control lines are in high impedance settings. The ID for the Receiver Line Control Packet is 15 (decimal).

**Table 14.10 Receiver Line Control Packet Bit Assignments**

	Bit 7	Bit 6	Bit 5	Bit 4	Bit 3	Bit 2	Bit 1	Bit 0
Byte 3	0	0	0	0	1	1	1	1
Byte 2	0	0	0	0	0	0	0	0
Byte 1	FRS <sub>7</sub>	FRS <sub>6</sub>	FRS <sub>5</sub>	FRS <sub>4</sub>	FRS <sub>3</sub>	FRS <sub>2</sub>	FRS <sub>1</sub>	FRS <sub>0</sub>
Byte 0	CLS <sub>7</sub>	CLS <sub>6</sub>	CLS <sub>5</sub>	CLS <sub>4</sub>	CLS <sub>3</sub>	CLS <sub>2</sub>	CLS <sub>1</sub>	CLS <sub>0</sub>

**FRS:** Force Receiver Setting. Setting a bit to one will cause the corresponding CLS bit in this packet to override the internal receiver control settings on the corresponding receiver control line (S0-S7). Clearing a bit gives control of the corresponding receiver control lines (S0-S7) back to the FLEX™ decoder II.(value after reset=0)

**CLS:** Control Line Setting. If the corresponding FRS bit was set in this packet, these bits define what setting should be applied to the corresponding receiver control lines.(value after reset=0)

### 14.3.9 Receiver Control Configuration Packets

These packets allow the host to configure what setting is applied to the receiver control lines S0-S7, how long to apply the setting, and when to read the value of the LOBAT input pin. For a more detailed description of how the FLEX™ decoder II uses these settings see 14.5.1, Receiver Control. The FLEX™ decoder II defines 12 different receiver control settings. Proper operation is not guaranteed if these settings are changed when decoding is enabled (i.e. the ON bit in the Control Packet is set). The IDs for these packets range from 16 to 27 (decimal).

#### 1. Receiver Off Setting Packet

**Table 14.11 Receiver Off Setting Packet Bit Assignments**

	Bit 7	Bit 6	Bit 5	Bit 4	Bit 3	Bit 2	Bit 1	Bit 0
Byte 3	0	0	0	1	0	0	0	0
Byte 2	0	0	0	0	LBC	0	0	0
Byte 1	CLS <sub>7</sub>	CLS <sub>6</sub>	CLS <sub>5</sub>	CLS <sub>4</sub>	CLS <sub>3</sub>	CLS <sub>2</sub>	CLS <sub>1</sub>	CLS <sub>0</sub>
Byte 0	ST <sub>7</sub>	ST <sub>6</sub>	ST <sub>5</sub>	ST <sub>4</sub>	ST <sub>3</sub>	ST <sub>2</sub>	ST <sub>1</sub>	ST <sub>0</sub>

**LBC:** Low Battery Check. If this bit is set, the FLEX™ decoder II will check the status of the LOBAT port just before leaving this receiver state. (value after reset=0)

**CLS:** Control Line Setting. This is the value to be output on the receiver control lines (S0-S7) for this receiver state. (value after reset=0)

**ST:** Step Time. This is the time the FLEX™ decoder II is to keep the receiver off before applying the first warm up state's receiver control value to the receiver control lines. The setting is in steps of 625µs. Valid values are 625µs (ST=01) to 159.375ms (ST=FF in hexadecimal). (value after reset=625µs)

## 2. Receiver Warm Up Setting Packets

**Table 14.12 Receiver Warm Up Setting Packet Bit Assignments**

	Bit 7	Bit 6	Bit 5	Bit 4	Bit 3	Bit 2	Bit 1	Bit 0
Byte 3	0	0	0	1	0	s <sub>2</sub>	s <sub>1</sub>	s <sub>0</sub>
Byte 2	SE	0	0	0	LBC	0	0	0
Byte 1	CLS <sub>7</sub>	CLS <sub>6</sub>	CLS <sub>5</sub>	CLS <sub>4</sub>	CLS <sub>3</sub>	CLS <sub>2</sub>	CLS <sub>1</sub>	CLS <sub>0</sub>
Byte 0	0	ST <sub>6</sub>	ST <sub>5</sub>	ST <sub>4</sub>	ST <sub>3</sub>	ST <sub>2</sub>	ST <sub>1</sub>	ST <sub>0</sub>

**s:** Setting Number. Receiver control setting for which this packet's values are to be applied. The following truth table shows the names of each of the values for s that apply to this packet.

s <sub>2</sub>	s <sub>1</sub>	s <sub>0</sub>	Setting Name
0	0	1	Warm Up 1
0	1	0	Warm Up 2
0	1	1	Warm Up 3
1	0	0	Warm Up 4
1	0	1	Warm Up 5

**SE:** Step Enable. The receiver setting is enabled when the bit is set. If a step in the warm up sequence is disabled, the disabled step and all remaining steps will be skipped. (value after reset=0)

**LBC:** Low Battery Check. If this bit is set, the FLEX™ decoder II will check the status of the LOBAT port just before leaving this receiver state. (value after reset=0)

**CLS:** Control Line Setting. This is the value to be output on the receiver control lines (S0-S7) for this receiver state. (value after reset=0)

**ST:** Step Time. This is the time the FLEX™ decoder II is to wait before applying the next state's receiver control value to the receiver control lines. The setting is in steps of 625μs. Valid values are 625μs (ST=01) to 79.375ms (ST=7F in hexadecimal). (value after reset=625μs)

### 3. 3200sps Sync Setting Packets

**Table 14.13 3200sps Sync Setting Packet Bit Assignments**

	Bit 7	Bit 6	Bit 5	Bit 4	Bit 3	Bit 2	Bit 1	Bit 0
Byte 3	0	0	0	1	0	1	1	0
Byte 2	0	0	0	0	LBC	0	0	0
Byte 1	CLS <sub>7</sub>	CLS <sub>6</sub>	CLS <sub>5</sub>	CLS <sub>4</sub>	CLS <sub>3</sub>	CLS <sub>2</sub>	CLS <sub>1</sub>	CLS <sub>0</sub>
Byte 0	0	ST <sub>6</sub>	ST <sub>5</sub>	ST <sub>4</sub>	ST <sub>3</sub>	ST <sub>2</sub>	ST <sub>1</sub>	ST <sub>0</sub>

**LBC:** Low Battery Check. If this bit is set, the FLEX™ decoder II will check the status of the LOBAT port just before leaving this receiver state. (value after reset=0)

**CLS:** Control Line Setting. This is the value to be output on the receiver control lines (S0-S7) for this receiver state. (value after reset=0)

**ST:** Step Time. This is the time the FLEX™ decoder II is to wait before expecting good signals on the EXTS1 and EXTS0 signals after warming up. The setting is in steps of 625μs. Valid values are 625μs (ST=01) to 79.375ms (ST=7F in hexadecimal). (value after reset=625μs)

### 4. Receiver On Setting Packets

**Table 14.14 Receiver On Setting Packet Bit Assignments**

	Bit 7	Bit 6	Bit 5	Bit 4	Bit 3	Bit 2	Bit 1	Bit 0
Byte 3	0	0	0	1	s <sub>3</sub>	s <sub>2</sub>	s <sub>1</sub>	s <sub>0</sub>
Byte 2	0	0	0	0	LBC	0	0	0
Byte 1	CLS <sub>7</sub>	CLS <sub>6</sub>	CLS <sub>5</sub>	CLS <sub>4</sub>	CLS <sub>3</sub>	CLS <sub>2</sub>	CLS <sub>1</sub>	CLS <sub>0</sub>
Byte 0	0	0	0	0	0	0	0	0

**s:** Setting Number. Receiver control setting for which this packet's values are to be applied. The following truth table shows the names of each of the values for s that apply to this packet.

$s_3$	$s_2$	$s_1$	$s_0$	Setting Name
0	1	1	1	1600sps Sync
1	0	0	0	3200sps Data
1	0	0	1	1600sps Data

**LBC:** Low Battery Check. If this bit is set, the FLEX™ decoder II will check the status of the LOBAT port just before leaving this receiver state. (value after reset=0)

**CLS:** Control Line Setting. This is the value to be output on the receiver control lines (S0-S7) for this receiver state. (value after reset=0)

## 5. Receiver Shut Down Setting Packets

**Table 14.15 Receiver Shut Down Setting Packet Bit Assignments**

	Bit 7	Bit 6	Bit 5	Bit 4	Bit 3	Bit 2	Bit 1	Bit 0
Byte 3	0	0	0	1	1	0	1	s
Byte 2	SE	0	0	0	LBC	0	0	0
Byte 1	CLS <sub>7</sub>	CLS <sub>6</sub>	CLS <sub>5</sub>	CLS <sub>4</sub>	CLS <sub>3</sub>	CLS <sub>2</sub>	CLS <sub>1</sub>	CLS <sub>0</sub>
Byte 0	0	0	ST <sub>5</sub>	ST <sub>4</sub>	ST <sub>3</sub>	ST <sub>2</sub>	ST <sub>1</sub>	ST <sub>0</sub>

**s:** Setting Number. Receiver control setting for which this packet's values are to be applied. The following truth table shows the names of each of the values for s that apply to this packet.

s	Setting Name
0	Shut Down 1
1	Shut Down 2

**SE:** Step Enable. The receiver setting is enabled when the bit is set. If a step in the shut down sequence is disabled, all steps following the disabled step will be ignored. (value after reset=0)

**LBC:** Low Battery Check. If this bit is set, the FLEX™ decoder II will check the status of the LOBAT port just before leaving this receiver state. (value after reset=0)

**CLS:** Control Line Setting. This is the value to be output on the receiver control lines (S0-S7) for this receiver state. (value after reset=0)



**ST:** Step Time. This is the time the FLEX™ decoder II is to wait before applying the next state's receiver control value to the receiver control lines. The setting is in steps of 625μs. Valid values are 625μs (ST=01) to 39.375ms (ST=3F in hexadecimal). (value after reset=625μs)

### 14.3.10 Frame Assignment Packets

The FLEX protocol defines that each address of a FLEX pager is assigned a home frame and a battery cycle. The FLEX™ decoder II must be configured so that a frame that is assigned by one or more of the addresses' home frames and battery cycles has its corresponding configuration bit set. For example, if the FLEX™ decoder II has one enabled address and it is assigned to frame 3 with a battery cycle of 4, the AF bits for frames 3, 19, 35, 51, 67, 83, 99, and 115 should be set and the AF bits for all other frames should be cleared.

When the FLEX™ decoder II is configured for manual collapse mode by setting the MCM bit in the Roaming Control Packet, the FLEX™ decoder II will not apply the received system collapse to the AF bits. The host should set the AF bits for all frames that should be decoded on all channels. For example, if frames 0 and 64 should be decoded on one channel and frames 4, 36, 68, and 100 should be decoded on another channel, all six of the corresponding AF bits should be set. The host can then change the receiver's carrier frequency after the FLEX™ decoder II decodes frames 0, 36, 64, and 100.

There are 8 Frame Assignment Packets. The Packet IDs for these packets range from 32 to 39 (decimal).

**Table 14.16 Frame Assignment Packet Bit Assignments**

	Bit 7	Bit 6	Bit 5	Bit 4	Bit 3	Bit 2	Bit 1	Bit 0
Byte 3	0	0	1	0	0	f <sub>2</sub>	f <sub>1</sub>	f <sub>0</sub>
Byte 2	0	0	0	0	0	0	0	0
Byte 1	AF <sub>15</sub>	AF <sub>14</sub>	AF <sub>13</sub>	AF <sub>12</sub>	AF <sub>11</sub>	AF <sub>10</sub>	AF <sub>9</sub>	AF <sub>8</sub>
Byte 0	AF <sub>7</sub>	AF <sub>6</sub>	AF <sub>5</sub>	AF <sub>4</sub>	AF <sub>3</sub>	AF <sub>2</sub>	AF <sub>1</sub>	AF <sub>0</sub>

**f:** Frame range. This value determines which 16 frames correspond to the 16 AF bits in the packet according to the following table. At least one of these bits must be set when the FLEX™ decoder II is turned on by setting the ON bit in the control packet. (value after reset=0)

$f_2$	$f_1$	$f_0$	$AF_{15}$	$AF_0$
0	0	0	Frame 127	Frame 112
0	0	1	Frame 111	Frame 96
0	1	0	Frame 95	Frame 80
0	1	1	Frame 79	Frame 64
1	0	0	Frame 63	Frame 48
1	0	1	Frame 47	Frame 32
1	1	0	Frame 31	Frame 16
1	1	1	Frame 15	Frame 0

**AF:** Assigned Frame. If a bit is set, the FLEX™ decoder II will consider the corresponding frame to be assigned via an address's home frame and pager collapse. (value after reset=0)

### 14.3.11 User Address Enable Packet

The User Address Enable Packet is used to enable and disable the 16 user address words. Although the host is allowed to change the user address words while the FLEX™ decoder II is decoding FLEX signals, the host must disable a user address word before changing it. The ID of the User Address Enable Packet is 120 (decimal).

**Table 14.17 User Address Enable Packet Bit Assignments**

	Bit 7	Bit 6	Bit 5	Bit 4	Bit 3	Bit 2	Bit 1	Bit 0
Byte 3	0	1	1	1	1	0	0	0
Byte 2	0	0	0	0	0	0	0	0
Byte 1	$UAE_{15}$	$UAE_{14}$	$UAE_{13}$	$UAE_{12}$	$UAE_{11}$	$UAE_{10}$	$UAE_9$	$UAE_8$
Byte 0	$UAE_7$	$UAE_6$	$UAE_5$	$UAE_4$	$UAE_3$	$UAE_2$	$UAE_1$	$UAE_0$

**UAE:** User Address Enable. When a bit is set, the corresponding user address word is enabled. When it is cleared, the corresponding user address word is disabled.  $UAE_0$  corresponds to the user address word configured using a packet ID of 128, and  $UAE_{15}$  corresponds to the user address word configured using a packet ID of 143. (value after reset=0)

### 14.3.12 User Address Assignment Packets

The FLEX™ decoder II has 16 user address words. Each word can be programmed to be a short address, part of a long address, or the first part of a network ID. The addresses are configured using the Address Assignment Packets. Each user address can be configured as long or short and tone-only or regular (network ID's are short and regular). Although the host is allowed to send these packets while the FLEX™ decoder II is on, the host must disable the user address word by clearing the corresponding UAE bit in the User Address Enable Packet before changing any of the bits in the corresponding User Address Assignment Packet. This method allows for easy reprogramming of user addresses without disrupting normal operation. The IDs for these packets range from 128 to 143 (decimal).

**Table 14.18 User Address Assignment Packet Bit Assignments**

	Bit 7	Bit 6	Bit 5	Bit 4	Bit 3	Bit 2	Bit 1	Bit 0
Byte 3	1	0	0	0	a <sub>3</sub>	a <sub>2</sub>	a <sub>1</sub>	a <sub>0</sub>
Byte 2	0	LA	TOA	A <sub>20</sub>	A <sub>19</sub>	A <sub>18</sub>	A <sub>17</sub>	A <sub>16</sub>
Byte 1	A <sub>15</sub>	A <sub>14</sub>	A <sub>13</sub>	A <sub>12</sub>	A <sub>11</sub>	A <sub>10</sub>	A <sub>9</sub>	A <sub>8</sub>
Byte 0	A <sub>7</sub>	A <sub>6</sub>	A <sub>5</sub>	A <sub>4</sub>	A <sub>3</sub>	A <sub>2</sub>	A <sub>1</sub>	A <sub>0</sub>

**a:** User Address Word Number. This specifies which address word is being configured. A zero in this field corresponds to address index zero (AI = 0) in the Address Packet received from the FLEX™ decoder II when an address is detected. See 14.4.2, Address Packet for a description of the address index field.

**LA:** Long address. When this bit is set, the address is considered a long address. Both words of a long address must have this bit set. The first word of a long address must have an even address index and the second word must be in the address index immediately following the first word.

**TOA:** Tone-Only Address. When this bit is set, the FLEX™ decoder II will consider this address a tone-only address and will not decode a vector word when the address is received. If the TOA bit of a long address word is set, the TOA bit of the other word of the long address must also be set.

**A:** Address word. This is the 21 bit value of the address word. Valid FLEX messaging addresses or Network ID's may be used.

## 14.4 Decoder-to-Host Packet Descriptions

The following sections describe the packets of information that will be sent from the FLEX™ decoder II to the host. In all cases the packets are sent MSB first (bit 7 of byte 3 = bit 31 of the packet = MSB). The FLEX™ decoder II decides what data should be sent to the host. If the FLEX™ decoder II is disabled through the checksum feature (see 14.3.1, Checksum Packet for a description of the checksum feature) the Part ID Packet will be sent. Data Packets relating to data received over the air are buffered in the 32 packet transmit buffer. The Data packets include Block Information Word Packets, Address Packets, Vector Packets, and Message Packets.

If the FLEX™ decoder II is enabled and a receiver shutdown packet is pending, the receiver shutdown packet will be sent. If there is no receiver shutdown packet pending, but there is a roaming status packet pending, the roaming status packet will be sent. If neither the receiver shutdown packet nor the roaming status packet is pending and there is data in the transmit buffer, a packet from the transmit buffer will be sent. Otherwise, the FLEX™ decoder II will send the Status Packet (which is not buffered). In the event of a buffer overflow, the FLEX™ decoder II will automatically stop decoding and clear the buffer.

It is recommended that the Host be designed to empty the FIFO buffer every block with enough time left over to read a status packet. This would ensure that any applicable Status Packet would be received within 1 block of the new status being available.

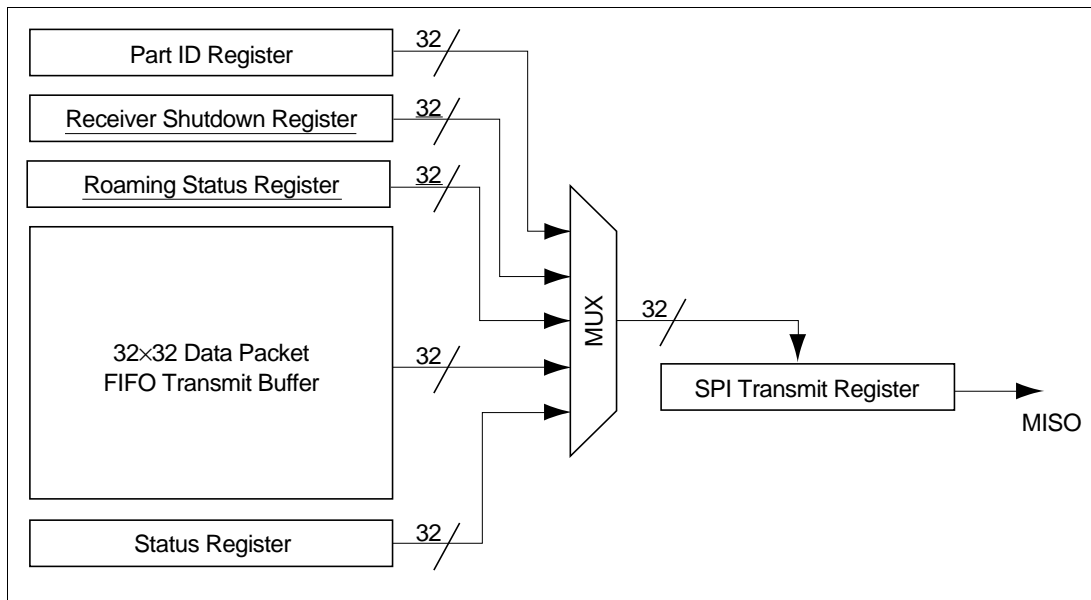


Figure 14.8 FLEX™ decoder II SPI Transmit Functional Block Diagram

## 14.4.1 Block Information Word Packet

The Block Information Field is the first field following the synchronization codes of the FLEX protocol. This field contains information about the frame such as number of addresses and messages, information about current time, the channel ID, channel attributes, etc. The first block information word of each phase is used internally to the FLEX™ decoder II and is never transmitted to the host with the exception of the system collapse which is sent to the host when the FLEX™ decoder II is in manual collapse mode.

Time block information words 2-4 can be optionally sent to the host by setting the SBI bit in the control packet (see 14.3.3, Control Packet). All block information words 2-4 can be optionally sent to the host by setting the ABI bit in the roaming control packet. When the SBI or ABI bit is set and any block information word 2-4 is received with an uncorrectable number of biterrors, the FLEX™ decoder II will send the block information word to the host with the e bit set regardless of the value of the f field in the block information word. The FLEX™ decoder II does not support decoding of the vector and message words associated with the Data/System Message block info word (f=101). The ID of a Block Information Word Packet is 0 (decimal).

**Table 14.19 Block Information Word Packet Bit Assignments**

	Bit 7	Bit 6	Bit 5	Bit 4	Bit 3	Bit 2	Bit 1	Bit 0
Byte 3	0	0	1	0	0	0	0	0
Byte 2	e	p <sub>1</sub>	p <sub>0</sub>	x	x	f <sub>2</sub>	f <sub>1</sub>	f <sub>0</sub>
Byte 1	x	x	s <sub>13</sub>	s <sub>12</sub>	s <sub>11</sub>	s <sub>10</sub>	s <sub>9</sub>	s <sub>8</sub>
Byte 0	s <sub>7</sub>	s <sub>6</sub>	s <sub>5</sub>	s <sub>4</sub>	s <sub>3</sub>	s <sub>2</sub>	s <sub>1</sub>	s <sub>0</sub>

**e:** Set if more than 2 bit errors are detected in the word or if the check character calculation fails after error correction has been performed.

**p:** Phase on which the block information word was found (0=a, 1=b, 2=c, 3=d)

**x:** Unused bits. The value of these bits is not guaranteed.

**f:** Word Format Type. The value of these bits modify the meaning of the s bits in this packet as described in the BIW word descriptions in the s bit definition below.

**s:** These are the information bits of the block information word. The definition of these bits depend on the f bits in this packet. The following table describes the block information words.

$f_2$	$f_1$	$f_0$	$s_{13}$	$s_{12}$	$s_{11}$	$s_{10}$	$s_9$	$s_8$	$s_7$	$s_6$	$s_5$	$s_4$	$s_3$	$s_2$	$s_1$	$s_0$	Description
0	0	0* <sup>1</sup>	$i_8$	$i_7$	$i_6$	$i_5$	$i_4$	$i_3$	$i_2$	$i_1$	$i_0$	$C_4$	$C_3$	$C_2$	$C_1$	$C_0$	Local ID, Coverage Zone
0	0	1* <sup>2</sup>	$m_3$	$m_2$	$m_1$	$m_0$	$d_4$	$d_3$	$d_2$	$d_1$	$d_0$	$Y_4$	$Y_3$	$Y_2$	$Y_1$	$Y_0$	Month, Day, Year
0	1	0* <sup>2</sup>	$S_2$	$S_1$	$S_0$	$M_5$	$M_4$	$M_3$	$M_2$	$M_1$	$M_0$	$H_4$	$H_3$	$H_2$	$H_1$	$H_0$	Second, Minute, Hour
0	1	1* <sup>1</sup>	Reserved by FLEX protocol for future use														
1	0	0* <sup>1</sup>	Reserved by FLEX protocol for future use														
1	0	1* <sup>2</sup>	$z_9$	$z_8$	$z_7$	$z_6$	$z_5$	$z_4$	$z_3$	$z_2$	$z_1$	$z_0$	$A_3$	$A_2$	$A_1$	$A_0$	System Message
1	1	0* <sup>1</sup>	Reserved by FLEX protocol for future use														
1	1	1* <sup>1</sup>	$c_9$	$c_8$	$c_7$	$c_6$	$c_5$	$c_4$	$c_3$	$c_2$	$c_1$	$c_0$	$T_3$	$T_2$	$T_1$	$T_0$	Country Code, Traffic Management Flags

Notes: \*1 Will be decoded only if the ABI bit is set.

\*2 Will be decoded only if the SBI or ABI bit is set.

#### 14.4.2 Address Packet

The Address Field follows the Block Information Field in the FLEX protocol. It contains all of the addresses in the frame.

If less than three bit errors are detected in a received address word and it matches an enabled address assigned to the FLEX™ decoder II, an Address Packet will be sent to the host processor. The Address Packet contains assorted data about the address and its associated vector and message. The ID of an Address Packet is 1 (decimal).

**Table 14.20 Address Packet Bit Assignments**

	Bit 7	Bit 6	Bit 5	Bit 4	Bit 3	Bit 2	Bit 1	Bit 0
Byte 3	0	0	0	0	0	0	0	1
Byte 2	PA	$p_1$	$p_0$	LA	x	x	x	x
Byte 1	$AI_7$	$AI_6$	$AI_5$	$AI_4$	$AI_3$	$AI_2$	$AI_1$	$AI_0$
Byte 0	TOA	$WN_6$	$WN_5$	$WN_4$	$WN_3$	$WN_2$	$WN_1$	$WN_0$

**PA:** Priority Address. Set if the address was received as a priority address.

**p:** Phase on which the address was detected (0=a, 1=b, 2=c, 3=d)

**LA:** Long Address type. Set if the address was programmed in the FLEX™ decoder II as a long address.

**AI:** Address Index (valid values are 0 through 15 and 128 through 159). The index identifies which of the addresses was detected. Values 0 through 15 correspond to the 16 programmable

address words. Values 128 through 143 correspond to the 16 temporary addresses. Values 144 through 159 correspond to the 16 operator messaging addresses. For long addresses, the address detect packet will only be sent once and the index will refer to the second word of the address.

**TOA:** Tone Only Address. Set if the address was programmed in the FLEX™ decoder II as a tone-only address. This bit will never be set for temporary or operator messaging addresses. No vector word will be sent for tone-only addresses.

**WN:** Word number of vector (2 - 87). Describes the location in the frame of the vector word for the detected address. This value is invalid for this packet if the TOA bit is set.

**x:** Unused bits. The value of these bits is not guaranteed.

### 14.4.3 Vector Packet

The Vector Field follows the Address Field in the FLEX protocol. Each Vector Packet must be matched to its corresponding Address Packet. The ID of the vector packet is the word number where the vector word was received in the frame. This value corresponds to the WN bits sent in the associated address packet. The phase information in both the Address Packet and the Vector Packet must also match. It is important to note for long addresses, the first message word will be transmitted in the word location immediately following the associated vector. See 14.5.2, Message Building for a message building example. In this case, the word number (identified by  $b_6$  to  $b_0$ ) in the Vector Packet will indicate the message start of the second message word if the message is longer than 1 word.

There are several types of vectors - 3 types of Numeric Vectors, a Short Message / Tone Only Vector, a Hex / Binary Vector, an Alphanumeric Vector, a Secure Message Vector, and a Short Instruction Vector. Each is described in the following pages. Two of the modes of the Short Instruction Vector is used for assigning temporary addresses that may be associated with a group call.

The Numeric, Hex / Binary, Alphanumeric, and Secure Message Vector Packets have associated Message Word Packets in the message field. The host must use the n and b bits of the vector word to calculate what message word locations are associated with the vector. The message word locations and the phase must match.

Four of the vectors (Hex / Binary, Alphanumeric, Secure Message, and the temporary address assignment modes of the Short Instruction) enable the FLEX™ decoder II to begin the all frame mode. This mode is required to allow for the decoding of temporary addresses and / or fragmented messages. The host disables the All Frame Mode after the proper time by writing to the decoder via the All Frame Mode Packet. See 14.5.3, Building a Fragmented Message and 14.5.4, Operation of a Temporary Address for more information. For any Address Packet sent to the host (except tone-only addresses), a corresponding Vector Packet will always be sent. If more than two

bit errors are detected (via BCH calculations, parity calculations, check character calculations, or value validation) in the vector word the e bit will be set and the message words will not be sent.

## 1. Numeric Vector Packet

**Table 14.21 Numeric Vector Packet Bit Assignments**

	Bit 7	Bit 6	Bit 5	Bit 4	Bit 3	Bit 2	Bit 1	Bit 0
Byte 3	0	WN <sub>6</sub>	WN <sub>5</sub>	WN <sub>4</sub>	WN <sub>3</sub>	WN <sub>2</sub>	WN <sub>1</sub>	WN <sub>0</sub>
Byte 2	e	p <sub>1</sub>	p <sub>0</sub>	x	x	V <sub>2</sub>	V <sub>1</sub>	V <sub>0</sub>
Byte 1	x	x	K <sub>3</sub>	K <sub>2</sub>	K <sub>1</sub>	K <sub>0</sub>	n <sub>2</sub>	n <sub>1</sub>
Byte 0	n <sub>0</sub>	b <sub>6</sub>	b <sub>5</sub>	b <sub>4</sub>	b <sub>3</sub>	b <sub>2</sub>	b <sub>1</sub>	b <sub>0</sub>

**V:** Vector type identifier.

V <sub>2</sub>	V <sub>1</sub>	V <sub>0</sub>	Name	Description
0	1	1	Standard NumericVector	No special formatting of characters is specified
1	0	0	Special Format Numeric Vector	Formatting of the received characters is predetermined by special rules in the host.
1	1	1	Numbered Numeric Vector	The received information has been numbered by the service provider to indicate all messages have been properly received

**WN:** Word number of vector (2 - 87 decimal). Describes the location of the vector word in the frame.

**e:** Set if more than 2 bit errors are detected in the word, if the check character calculation fails after error correction has been performed, or if the vector value is determined to be invalid.

**p:** Phase on which the vector was found (0=a, 1=b, 2=c, 3=d)

**K:** Beginning check bits of the message.

**n:** Number of message words in the message including the second vector word for long addresses (000 = 1 word message, 001 = 2 word message, etc.). For long addresses, the first message word is located in the word location that immediately follows the associated vector.

**b:** Word number of message start in the message field (3-87 decimal). For long addresses, the word number indicates the location of the second message word.

**x:** Unused bits. The value of these bits is not guaranteed.



## 2. Short Message / Tone Only Vector

**Table 14.22 Short Message / Tone Only Vector Packet Bit Assignments**

	Bit 7	Bit 6	Bit 5	Bit 4	Bit 3	Bit 2	Bit 1	Bit 0
Byte 3	0	WN <sub>6</sub>	WN <sub>5</sub>	WN <sub>4</sub>	WN <sub>3</sub>	WN <sub>2</sub>	WN <sub>1</sub>	WN <sub>0</sub>
Byte 2	e	p <sub>1</sub>	p <sub>0</sub>	x	x	V <sub>2</sub>	V <sub>1</sub>	V <sub>0</sub>
Byte 1	x	x	d <sub>11</sub>	d <sub>10</sub>	d <sub>9</sub>	d <sub>8</sub>	d <sub>7</sub>	d <sub>6</sub>
Byte 0	d <sub>5</sub>	d <sub>4</sub>	d <sub>3</sub>	d <sub>2</sub>	d <sub>1</sub>	d <sub>0</sub>	t <sub>1</sub>	t <sub>0</sub>

**V:** 010 for a Short Message / Tone Only Vector

**WN:** Word number of vector (2 - 87 decimal). Describes the location of the vector word in the frame.

**e:** Set if more than 2 bit errors are detected in the word or, if after error correction, the check character calculation fails.

**p:** Phase on which the vector was found (0=a, 1=b, 2=c, 3=d)

**d:** Data bits whose definition depend on the value of t in this packet according to the following table. Note that if this vector is received on a long address and the e bit in this packet is not set, the decoder will send a Message Packet from the word location immediately following the Vector Packet. Except for the short message on a non-network address (t=0), all message bits in the Message Packet are unused and should be ignored.

t <sub>1</sub>	t <sub>0</sub>	d <sub>11</sub>	d <sub>10</sub>	d <sub>9</sub>	d <sub>8</sub>	d <sub>7</sub>	d <sub>6</sub>	d <sub>5</sub>	d <sub>4</sub>	d <sub>3</sub>	d <sub>2</sub>	d <sub>1</sub>	d <sub>0</sub>	Description
0	0	c <sub>3</sub>	c <sub>2</sub>	c <sub>1</sub>	c <sub>0</sub>	b <sub>3</sub>	b <sub>2</sub>	b <sub>1</sub>	b <sub>0</sub>	a <sub>3</sub>	a <sub>2</sub>	a <sub>1</sub>	a <sub>0</sub>	Short Numeric: 3 numeric chars* <sup>1</sup> when on a messaging address
0	0	T <sub>3</sub>	T <sub>2</sub>	T <sub>1</sub>	T <sub>0</sub>	M <sub>2</sub>	M <sub>1</sub>	M <sub>0</sub>	A <sub>4</sub>	A <sub>3</sub>	A <sub>2</sub>	A <sub>1</sub>	A <sub>0</sub>	Part of NID when on a Network Address
0	1	s <sub>8</sub>	s <sub>7</sub>	s <sub>6</sub>	s <sub>5</sub>	s <sub>4</sub>	s <sub>3</sub>	s <sub>2</sub>	s <sub>1</sub>	s <sub>0</sub>	S <sub>2</sub>	S <sub>1</sub>	S <sub>0</sub>	Tone Only: 8 sources (S) and 9 unused bits (s)
1	0	s <sub>1</sub>	s <sub>0</sub>	R <sub>0</sub>	N <sub>5</sub>	N <sub>4</sub>	N <sub>3</sub>	N <sub>2</sub>	N <sub>1</sub>	N <sub>0</sub>	S <sub>2</sub>	S <sub>1</sub>	S <sub>0</sub>	Tone Only: 8 sources (S), message number (N), message retrieval flag (R), and 2 unused bits (s)
1	1													spare message type

Note: For long addresses, an extra 5 characters are sent in the Message Packet immediately following the Vector Packet.

**t:** Message type. These bits define the meaning of the d bits in this packet.

**x:** Unused bits. The value of these bits is not guaranteed.

### 3. HEX / Binary, Alphanumeric, and Secure Message Vector

**Table 14.23 HEX / Binary, Alphanumeric, and Secure Message Vector Packet Bit Assignments**

	Bit 7	Bit 6	Bit 5	Bit 4	Bit 3	Bit 2	Bit 1	Bit 0
Byte 3	0	WN <sub>6</sub>	WN <sub>5</sub>	WN <sub>4</sub>	WN <sub>3</sub>	WN <sub>2</sub>	WN <sub>1</sub>	WN <sub>0</sub>
Byte 2	e	p <sub>1</sub>	p <sub>0</sub>	x	x	V <sub>2</sub>	V <sub>1</sub>	V <sub>0</sub>
Byte 1	x	x	n <sub>6</sub>	n <sub>5</sub>	n <sub>4</sub>	n <sub>3</sub>	n <sub>2</sub>	n <sub>1</sub>
Byte 0	n <sub>0</sub>	b <sub>6</sub>	b <sub>5</sub>	b <sub>4</sub>	b <sub>3</sub>	b <sub>2</sub>	b <sub>1</sub>	b <sub>0</sub>

**V:** Vector type identifier.

V <sub>2</sub> V <sub>1</sub> V <sub>0</sub>	Type
0 0 0	Secure
1 0 1	Alphanumeric
1 1 0	Hex / Binary

**WN:** Word number of vector (2 - 87 decimal). Describes the location of the vector word in the frame.

**e:** Set if more than 2 bit errors are detected in the word, if the check character calculation fails after error correction has been performed, or if the vector value is determined to be invalid.

**p:** Phase on which the vector was found (0=a, 1=b, 2=c, 3=d)

**n:** Number of message words in this frame including the first Message word that immediately follows a long address vector. Valid values are 1 through 85 decimal.

**b:** Word number of message start in the message field. Valid values are 3 through 87 decimal.

**x:** Unused bits. The value of these bits is not guaranteed.

**Note:** For long addresses, the first Message Packet is sent from the word location immediately following the word location of the Vector Packet. The b bits indicate the second message word in the message field if one exists.

#### 4. Short Instruction Vector

**Table 14.24 Short Instruction Vector Packet Bit Assignments**

	Bit 7	Bit 6	Bit 5	Bit 4	Bit 3	Bit 2	Bit 1	Bit 0
Byte 3	0	WN <sub>6</sub>	WN <sub>5</sub>	WN <sub>4</sub>	WN <sub>3</sub>	WN <sub>2</sub>	WN <sub>1</sub>	WN <sub>0</sub>
Byte 2	e	p <sub>1</sub>	p <sub>0</sub>	x	x	V <sub>2</sub>	V <sub>1</sub>	V <sub>0</sub>
Byte 1	x	x	d <sub>10</sub>	d <sub>9</sub>	d <sub>8</sub>	d <sub>7</sub>	d <sub>6</sub>	d <sub>5</sub>
Byte 0	d <sub>4</sub>	d <sub>3</sub>	d <sub>2</sub>	d <sub>1</sub>	d <sub>0</sub>	i <sub>2</sub>	i <sub>1</sub>	i <sub>0</sub>

**V:** 001 for a Short Instruction Vector

**WN:** Word number of vector (2 - 87 decimal). Describes the location of the vector word in the frame.

**e:** Set if more than 2 bit errors are detected in the word or, if after error correction, the check character calculation fails.

**p:** Phase on which the vector was found (0=a, 1=b, 2=c, 3=d)

**d:** Data bits whose definition depend on the i bits in this packet according to the following table. Note that if this vector is received on a long address and the e bit in this packet is not set, the decoder will send a Message Packet immediately following the Vector Packet. All message bits in the message packet are unused and should be ignored for all modes except the Temporary address assignment with MSN (i<sub>2</sub> i<sub>1</sub> i<sub>0</sub>=010).

i <sub>2</sub>	i <sub>1</sub>	i <sub>0</sub>	d <sub>10</sub>	d <sub>9</sub>	d <sub>8</sub>	d <sub>7</sub>	d <sub>6</sub>	d <sub>5</sub>	d <sub>4</sub>	d <sub>3</sub>	d <sub>2</sub>	d <sub>1</sub>	d <sub>0</sub>	Description
0	0	0	a <sub>3</sub>	a <sub>2</sub>	a <sub>1</sub>	a <sub>0</sub>	f <sub>6</sub>	f <sub>5</sub>	f <sub>4</sub>	f <sub>3</sub>	f <sub>2</sub>	f <sub>1</sub>	f <sub>0</sub>	Temporary address assignment* <sup>1</sup>
0	0	1	d <sub>10</sub>	d <sub>9</sub>	d <sub>8</sub>	d <sub>7</sub>	d <sub>6</sub>	d <sub>5</sub>	d <sub>4</sub>	d <sub>3</sub>	d <sub>2</sub>	d <sub>1</sub>	d <sub>0</sub>	11 Event Flags for System Event
0	1	0	a <sub>3</sub>	a <sub>2</sub>	a <sub>1</sub>	a <sub>0</sub>	f <sub>6</sub>	N <sub>5</sub>	N <sub>4</sub>	N <sub>3</sub>	N <sub>2</sub>	N <sub>1</sub>	N <sub>0</sub>	Temporary address assignment with MSN* <sup>2</sup>
0	1	1												Reserved
1	0	0												Reserved
1	0	1												Reserved
1	1	0												Reserved
1	1	1												Reserved for test

Notes: \*1 Assigned temporary address (a) and assigned frame (f). See 14.5.4, Operation of a Temporary Address for a description of the use of these fields.

\*2 Assigned temporary address (a), MSb of assigned frame (f<sub>6</sub>), and message sequence number (N). The message packet sent with this instruction on long addresses contains extra frame information, see 14.5.4, Operation of a Temporary Address for a description and for details on the use of the other fields.

**i:** Instruction type. These bits define the meaning of the d bits in this packet.

**x:** Unused bits. The value of these bits is not guaranteed.

#### 14.4.4 Message Packet

The Message Field follows the Vector Field in the FLEX protocol. It contains the message data, checksum information, and may contain fragment numbers and message numbers.

If the error bit of a vector word is not set and the vector word indicates that there are message words associated with the page, the message words are sent in Message Packets.

The ID of the Message Packet is the word number where the message word was received in the frame.

**Table 14.25 Message Packet Bit Assignments**

	Bit 7	Bit 6	Bit 5	Bit 4	Bit 3	Bit 2	Bit 1	Bit 0
Byte 3	0	WN <sub>6</sub>	WN <sub>5</sub>	WN <sub>4</sub>	WN <sub>3</sub>	WN <sub>2</sub>	WN <sub>1</sub>	WN <sub>0</sub>
Byte 2	e	p <sub>1</sub>	p <sub>0</sub>	i <sub>20</sub>	i <sub>19</sub>	i <sub>18</sub>	i <sub>17</sub>	i <sub>16</sub>
Byte 1	i <sub>15</sub>	i <sub>14</sub>	i <sub>13</sub>	i <sub>12</sub>	i <sub>11</sub>	i <sub>10</sub>	i <sub>9</sub>	i <sub>8</sub>
Byte 0	i <sub>7</sub>	i <sub>6</sub>	i <sub>5</sub>	i <sub>4</sub>	i <sub>3</sub>	i <sub>2</sub>	i <sub>1</sub>	i <sub>0</sub>

**WN:** Word number of message word (3 - 87 decimal). Describes the location of the message word in the frame.

**e:** Set if more than 2 bit errors are detected in the word.

**p:** Phase on which the message word was found (0=a, 1=b, 2=c, 3=d)

**i:** These are the information bits of the message word. The definitions of these bits depend on the vector type and which word of the message is being received.

#### 14.4.5 Roaming Status Packet

The contents of this section apply to the FLEX Roaming Decoder. They are not applicable to the FLEX Non-Roaming Decoder.

The FLEX™ decoder II will automatically prompt the host to read a Roaming Status Packet if RSR, MS1, MFI, MS2, MBI, MAW, NBU, NDR<sub>1</sub>, NDR<sub>0</sub>, or SCU is set.

**Table 14.26 Roaming Status Packet Bit Assignments**

	Bit 7	Bit 6	Bit 5	Bit 4	Bit 3	Bit 2	Bit 1	Bit 0
Byte 3	0	1	1	0	0	0	0	0
Byte 2	RSR	MS1	MFI	MS2	MBI	MAW	NBU	n
Byte 1	x	x	x	x	x	x	NDR <sub>1</sub>	NDR <sub>0</sub>
Byte 0	x	x	x	x	SCU	RSC <sub>2</sub>	RSC <sub>1</sub>	RSC <sub>0</sub>

**RSR:** Re-synchronization Signal Received. Set when the FLEX™ decoder II detected a re-synchronization signal and the host configured the FLEX™ decoder II to ignore it via the IRS bit in the roaming control packet. This bit is cleared when read.

**MS1:** Missed Synchronization 1. Set when the FLEX™ decoder II failed to detect the first synchronization pattern ( $A / \bar{A}$ ) of a FLEX frame and the FLEX™ decoder II was configured to report missed frame information via the MFC bit in the roaming control packet. This bit is cleared when read.

**MFI:** Missed Frame Information word. Set when the frame information word is received with an uncorrectable number of errors and the FLEX™ decoder II was configured to report missed frame information via the MFC bit in the roaming control packet. This bit is cleared when read.

**MS2:** Missed Synchronization 2. Set when the FLEX™ decoder II failed to detect the second synchronization pattern ( $C / \bar{C}$ ) of a frame and FLEX™ decoder II was configured to report missed frame information via the MFC bit in the roaming control packet. This bit is cleared when read.

**MBI:** Missed Block Information word 1. Set when at least one of the block information word ones is received with an uncorrectable number of errors and FLEX™ decoder II was configured to report missed frame information via the MFC bit in the roaming control packet. This bit is set no more than once per frame regardless of the number of missed block information word 1's in the frame. This bit is cleared when read.

**MAW:** Missed Address Word. Set when any address words in the address field is received with an uncorrectable number of errors and FLEX™ decoder II was configured to report missed frame information via the MFC bit in the roaming control packet. This bit is set no more than once per frame regardless of the number of missed address words in the frame. This bit is cleared when read.

**NBU:** Network Bit Update. Set when the NBC bit in the roaming control packet is set and a frame information word is received with a correctable number of errors. This bit will not be set when the frame information word is not received due to missing the first synchronization pattern ( $A / \bar{A}$ ). This bit is cleared when read.

**n:** Network bit value. When NBU is set, this is the value of the n bit in the last received frame information word.

**NDR:** Noise Detect Result. These bits indicate the result of a noise detect. The results of noise detects initiated by setting the SND bit in the roaming control packet will always be reported. The results of the automatic noise detects performed in asynchronous mode will only be reported if the RND bit is set in the roaming control packet. When continuous noise detects during block data are enabled by setting the CND bit in the roaming control packet, only the “No FLEX signal detected” result will be reported. These bits are cleared when read.

<b>NDR</b>	<b>Noise Detect Result</b>
00	No Information
01	Noise Detect was abandoned
10	FLEX signal detected
11	FLEX signal not detected

**SCU:** System Collapse Update. Set when the FLEX™ decoder II is configured for manual collapse mode by setting the MCM bit in the roaming control packet and the system collapse of a frame is received. This bit is set no more than once per frame regardless of the number of phases in the frame. This bit will not be set in frames in which no block information word ones is received properly. This bit is cleared when read.

**RSC:** Received System Collapse. When SCU is set, this value represents the system collapse value that was received in the frame.

## 14.4.6 Receiver Shutdown Packet

The contents of this section apply to the FLEX Roaming Decoder. They are not applicable to the FLEX Non-Roaming Decoder.

The Shutdown Packet is sent in both synchronous and asynchronous mode. It is designed to indicate to the host that the receiver is turned off and how much time there is until the FLEX™ decoder II will automatically turn it back on.

**Table 14.27 Receiver Shut Down Packet Bit Assignments**

	Bit 7	Bit 6	Bit 5	Bit 4	Bit 3	Bit 2	Bit 1	Bit 0
Byte 3	0	1	1	1	1	1	1	1
Byte 2	FNV	CF <sub>6</sub>	CF <sub>5</sub>	CF <sub>4</sub>	CF <sub>3</sub>	CF <sub>2</sub>	CF <sub>1</sub>	CF <sub>0</sub>
Byte 1	TNF <sub>7</sub>	TNF <sub>6</sub>	TNF <sub>5</sub>	TNF <sub>4</sub>	TNF <sub>3</sub>	TNF <sub>2</sub>	TNF <sub>1</sub>	TNF <sub>0</sub>
Byte 0	FCO	NAF <sub>6</sub>	NAF <sub>5</sub>	NAF <sub>4</sub>	NAF <sub>3</sub>	NAF <sub>2</sub>	NAF <sub>1</sub>	NAF <sub>0</sub>

**FNV:** Frame Number Valid. This bit is set if the last decoded frame info word was correctable and the frame number was the expected value. When in asynchronous mode, this value will be 0.

**CF:** Current Frame. When in synchronous mode, this is the current frame number. This value is latched on the negative edge of the  $\overline{\text{READY}}$  line when this packet is sent to the host. The value of this field is valid only if the FLEX™ decoder II is in synchronous mode and the FIV bit in the status packet is set. When in asynchronous mode, this value will be 0.

**TNF:** Time to Next Frame. When in synchronous mode TNF indicates the time to the start of the A-word check if the FLEX™ decoder II were to warm up for the next frame. When in asynchronous mode TNF indicates the time to the start of the next automatic noise detect. See “Using the Receiver Shutdown Packet” on page 66 for an explanation on how to use this value. This value is latched on the negative edge of the  $\overline{\text{READY}}$  line when this packet is sent to the host.

**FCO:** Frame Carried On. Set if the FLEX™ decoder II is decoding the next frame due to the reception of a non-zero carry-on value in the current or a previous frame. When in asynchronous mode, this value will be 0.

**NAF:** Next Assigned Frame. This is the frame number of the next frame the FLEX™ decoder II was scheduled to decode when the receiver shut down. The value of this field is valid only if the FLEX™ decoder II is in synchronous mode and the FIV bit in the status packet is set. When in asynchronous mode this value will be 0.

## 14.4.7 Status Packet

The Status Packet contains various types of information that the host may require. The Status Packet will be sent to the host whenever the FLEX™ decoder II is polled and has no other data to send. The FLEX™ decoder II can also prompt the host to read the Status Packet due to events for which the FLEX™ decoder II was configured to send it (see 14.3.2, Configuration Packet and 14.3.3, Control Packet for a detailed description of the bits). The FLEX™ decoder II will prompt the host to read a Status Packet if the...

1. ... SMU bit in the Status Packet and the SME bit in the Configuration Packet are set.
2. ... MT bit in the Status Packet and the MTE bit in the Configuration Packet are set.
3. ... EOF bit in the Status Packet is set.
4. ... LBU bit in the Status Packet is set.
5. ... EA bit in the Status Packet is set.
6. ... BOE bit in the Status Packet is set.

The ID of the Status Packet is 127 (decimal).

**Table 14.28 Status Packet Bit Assignments**

	Bit 7	Bit 6	Bit 5	Bit 4	Bit 3	Bit 2	Bit 1	Bit 0
Byte 3	0	1	1	1	1	1	1	1
Byte 2	FIV	f <sub>6</sub>	f <sub>5</sub>	f <sub>4</sub>	f <sub>3</sub>	f <sub>2</sub>	f <sub>1</sub>	f <sub>0</sub>
Byte 1	SM	LB	x	x	c <sub>3</sub>	c <sub>2</sub>	c <sub>1</sub>	c <sub>0</sub>
Byte 0	SMU	LBU	x	MT	x	EOF	EA	BOE

**FIV:** Frame Info Valid. Set when a valid frame info word has been received since becoming synchronous to the system and the f and c fields contain valid values. If this bit is clear, no valid frame info words have been received since the FLEX™ decoder II became synchronous to the system. This value will change from 0 to 1 at the end of block 0 of the frame in which the 1st frame info word was properly received. It will be cleared when the FLEX™ decoder II goes into asynchronous mode. This bit is initialized to 0 when the FLEX™ decoder II is reset and when the FLEX™ decoder II is turned off by clearing the ON bit in the Control Packet.

**f:** Current frame number. This value is updated every frame regardless of whether the FLEX™ decoder II needs to decode the frame. This value will change to its proper value for a frame at the end of block 0 of the frame. The value of these bits is not guaranteed when FIV is 0.

**SM:** Synchronous Mode. This bit is set when the FLEX™ decoder II is synchronous to the system. The FLEX™ decoder II will set this bit when the first synchronization words are received. It will clear this bit when the FLEX™ decoder II has not properly received both synchronization words in any frame for 8, 16, or 32 minutes (depending on the number of assigned frames and the



system collapse). This bit is initialized to 0 when the FLEX™ decoder II is reset and when it is turned off by clearing the ON bit in the Control Packet.

**LB:** Low Battery. Set to the value last read from the LOBAT pin. The host controls when the LOBAT pin is read via the Receiver Control Packets. This bit is initialized to 0 at reset. It is also initialized to the inverse of the LBP bit in the Configuration Packet when the FLEX™ decoder II is turned on by setting the ON bit in the Control Packet.

**c:** Current system cycle number. This value is updated every frame regardless of whether the FLEX™ decoder II needs to decode the frame. This value will change to its proper value for a frame at the end of block 0 of the frame. The value of these bits is not guaranteed when FIV is 0.

**SMU:** Synchronous Mode Update. Set if the SM bit has been updated in this packet. When the FLEX™ decoder II is turned on, this bit will be set when the first synchronization words are found (SM changes to 1) or when the first synchronization search window after the FLEX™ decoder II is turned on expires (SM stays 0). The latter condition gives the host the option of assuming the paging device is in range when it is turned on, and displaying out-of-range only after the initial A search window expires. After the initial synchronous mode update, the SMU bit will be set whenever the FLEX™ decoder II transitions from/to synchronous mode. Cleared when read. Changes in the SM bit due to turning off the FLEX™ decoder II will not cause the SMU bit to be set. This bit is initialized to 0 when the FLEX™ decoder II is reset.

**LBU:** Low Battery Update. Set if the value on two consecutive reads of the LOBAT pin yielded different results. Cleared when read. The host controls when the LOBAT pin is read via the Receiver Control Packets. Changes in the LB bit due to turning on the FLEX™ decoder II will not cause the LBU bit to be set. This bit is initialized to 0 when the FLEX™ decoder II is reset.

**MT:** Minute Time-out. Set if one minute has elapsed. Cleared when read. This bit is initialized to 0 when the FLEX™ decoder II is reset.

**EOF:** End Of Frame. Set when the FLEX™ decoder II is in all frames mode and the end of frame has been reached. The FLEX™ decoder II is in all frames mode if the all frames mode enable counter is non-zero, if any temporary address enabled counter is non-zero, or if the FAF bit in the All Frame Mode Packet is set. Cleared when read. This bit is initialized to 0 when the FLEX™ decoder II is reset.

**EA:** End of Addresses. If EAE of the control packet is set and an address is detected in a frame, EA will be set after the FLEX™ decoder II processes the last address in the frame. Since data packets take priority over the status packet, the status packet with the EA bit set is guaranteed to come after all address packets for the frame. Cleared when read. This bit is initialized to 0 when the FLEX™ decoder II is reset.

**BOE:** Buffer Overflow Error. Set when information has been lost due to slow host response time. When the data packet FIFO transmit buffer on the FLEX™ decoder II overflows, the FLEX™

decoder II clears the buffer, turns off decoding by clearing the ON bit in the Control Packet, and sets this bit. Cleared when read. This bit is initialized to 0 when the FLEX™ decoder II is reset.

**x:** Unused bits. The value of these bits is not guaranteed.

#### 14.4.8 Part ID Packet

The Part ID Packet is sent by the FLEX™ decoder II whenever the FLEX™ decoder II is disabled due to the checksum feature. See 14.3.1, Checksum Packet for a description of the checksum feature. Since the FLEX™ decoder II is disabled after reset, this is the first packet that will be received by the host after reset. The ID of the Part ID Packet is 255 (decimal).

**Table 14.29 Part ID Packet Bit Assignments**

	Bit 7	Bit 6	Bit 5	Bit 4	Bit 3	Bit 2	Bit 1	Bit 0
Byte 3	1	1	1	1	1	1	1	1
Byte 2	MDL <sub>1</sub>	MDL <sub>0</sub>	CID <sub>13</sub>	CID <sub>12</sub>	CID <sub>11</sub>	CID <sub>10</sub>	CID <sub>9</sub>	CID <sub>8</sub>
Byte 1	CID <sub>7</sub>	CID <sub>6</sub>	CID <sub>5</sub>	CID <sub>4</sub>	CID <sub>3</sub>	CID <sub>2</sub>	CID <sub>1</sub>	CID <sub>0</sub>
Byte 0	REV <sub>7</sub>	REV <sub>6</sub>	REV <sub>5</sub>	REV <sub>4</sub>	REV <sub>3</sub>	REV <sub>2</sub>	REV <sub>1</sub>	REV <sub>0</sub>

**MDL:** Model. This identifies the FLEX™ decoder II model. Current value is 0.

**CID:** Compatibility ID. This value describes the FLEX™ decoders to which this part is backwards compatible. See table below for meaning and current value.

Bit	Indicates this IC can be used in place of	Value for FLEX Roaming Decoder II
CID <sub>0</sub>	FLEX Alphanumeric Decoder I* <sup>1</sup>	1 (TRUE)
CID <sub>1</sub>	FLEX Roaming Decoder I* <sup>2</sup>	1 (TRUE)
CID <sub>2</sub>	FLEX Numeric Decoder	0 (FALSE)

Notes: \*1 Compatibility to FLEX Alphanumeric Decoder II is indicated by MDL set to 0, CID 0 set to 1, and REV greater than or equal to 7.

\*2 Compatibility to FLEX Roaming Decoder II is indicated by MDL set to 0, CID 1 set to 1, and REV greater than or equal to 8.

**REV:** Revision. This identifies the revision and manufacturer of the FLEX™ decoder II. The following table lists the currently available part ID's of the FLEX™ decoder II family.

<b>Part ID Packet (Hex)</b>	<b>Revision</b>	<b>Manufacturer</b>
00 01 03	FLEX Alphanumeric Decoder I	Texas Instruments
00 01 04	FLEX Alphanumeric Decoder I	Motorola Semiconductor Products Sector
00 01 06	FLEX Alphanumeric Decoder I	Philips
00 01 07	FLEX Alphanumeric Decoder II	Motorola Semiconductor Products Sector
00 01 08	FLEX Alphanumeric Decoder II	Texas Instruments
00 03 03	FLEX Roaming Decoder I	Motorola Semiconductor Products Sector
00 03 05	FLEX Roaming Decoder I	Texas Instruments
00 03 09	FLEX Roaming Decoder II	Motorola Semiconductor Products Sector
00 03 0A	FLEX Roaming Decoder II	Texas Instruments
00 04 01	FLEX Numeric Decoder	Texas Instruments
00 01 15	FLEX Alphanumeric Decoder II	HITACHI H8/3937 Series
00 01 16	FLEX Alphanumeric Decoder II	HITACHI H8S/2276 Series
00 03 15	FLEX Roaming Decoder II	HITACHI H8/3937 Series
00 03 16	FLEX Roaming Decoder II	HITACHI H8S/2276 Series

## 14.5 Application Notes

### 14.5.1 Receiver Control

**Introduction:** The FLEX™ decoder II has 8 programmable receiver control lines (S0-S7). The host has control of the receiver warm up and shut down timing as well as all of the various settings on the control lines through configuration registers on the FLEX™ decoder II. The configuration registers for most settings allow the host to configure what setting is applied to the control lines, how long to apply the setting, and if the LOBAT input pin is polled before changing from the setting. With this programmability, the FLEX™ decoder II should be able to interface with many off-the-shelf receiver ICs. When using the internal demodulator (i.e. when the IDE bit of the configuration packet is set), the S0 pin becomes the input for the demodulator and the S0 register setting in the receiver control configuration packets controls the tracking mode of the peak and valley detectors for the internal data slicer. When the S0 bit is set in a receiver setting, the internal data slicer will be in fast track mode. When the S0 bit is cleared in a receiver setting, the internal data slicer will be in slow track mode. For details on the configuration of the receiver control settings, see 14.3.9, Receiver Control Configuration Packets.

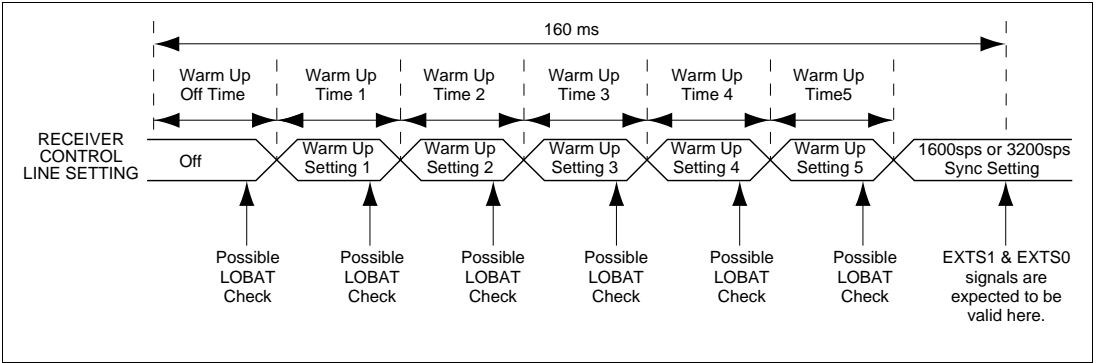
#### 1. Receiver Settings at Reset

The receiver control ports are three-state outputs which are set to the high-impedance state when the FLEX™ decoder II is reset and until the corresponding FRS bit in the Receiver Line Control Packet is set or until the FLEX™ decoder II is turned on by setting the ON bit in the Control Packet. This allows the designer to force the receiver control lines to the receiver off setting with external pull-up or pull-down resistors before the host can configure these settings in the FLEX™ decoder II. When the FLEX™ decoder II is turned on, the receiver control ports are driven to the settings configured by the “14.3.9 Receiver Control Configuration Packets” until the FLEX™ decoder II is reset again.

#### 2. Automatic Receiver Warm Up Sequence

The FLEX™ decoder II allows for up to 6 steps associated with warming up the receiver. When the FLEX™ decoder II automatically turns on the receiver, it starts the warm up sequence 160 ms before it requires valid signals at the EXTS0 and EXTS1 input pins (or the equivalent internal signals when using the internal demodulator/data slicer). The first step of the warm up sequence involves leaving the receiver control lines in the “Off” state for the amount of time programmed for “Warm Up Off Time”. At the end of the “Warm Up Off Time”, the first warm up setting, if enabled, is applied to the receiver control lines for the amount of time programmed for that setting. Each subsequent warm up setting is applied to the receiver control lines for their corresponding time until a disabled warm up setting is found. At the end of the last used warm up setting, the “1600sps Sync Setting” or the “3200sps Sync Setting” is applied to the receiver control lines depending on the current state of the FLEX™ decoder II. The sum total of all of the used warm up times and the “Warm Up Off Time” must not exceed 160ms. If it exceeds 160ms, the FLEX™ decoder II will execute the receiver shut down sequence at the end of the 160ms warm up period.

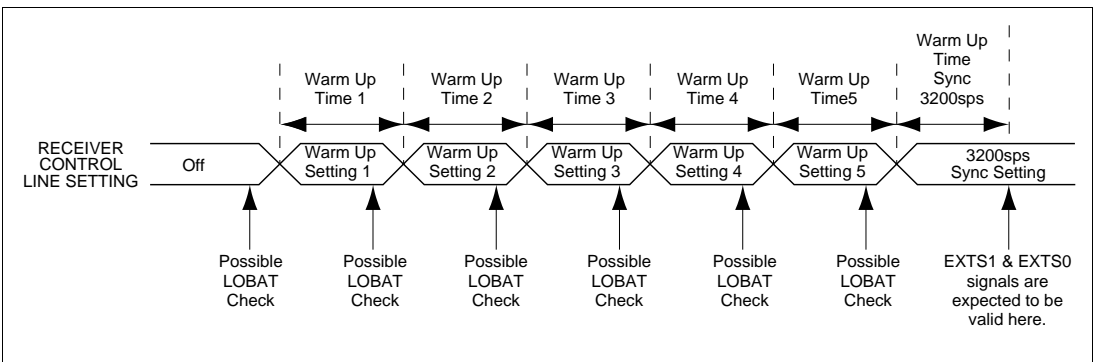
The receiver warm up sequence while decoding when all warm up settings are enabled is shown in figure 14.9.



**Figure 14.9 Automatic Receiver Warm Up Sequence**

### 3. Host Initiated Receiver Warm Up Sequence

The host can cause the FLEX™ decoder II to warm-up the receiver in three ways: (1) by turning on the FLEX™ decoder II by setting the ON bit in the control packet; (2) by requesting a noise detect by setting the SND bit in the roaming control packet; or (3) by requesting an A-word search by setting the SAS bit in the roaming control packet. When the FLEX™ decoder II warms up the receiver in response to a host request, the first warm up setting, if enabled, is applied to the receiver control lines for the amount of time programmed for that setting. Each subsequent warm up setting is applied to the receiver control lines for their corresponding time until a disabled warm up setting is found. Once a disabled warm up setting is found, the “3200sps Sync Setting” (for ON and SND warm ups) or the “1600sps Sync Setting” (for SAS warm ups) is applied to the receiver control lines and the decoder does not expect valid signal until after the “3200sps Sync Warm Up Time” (for ON, SND, and SAS warm ups) has expired. In figure 14.10 the receiver warm up sequence when the host initiates a warm-up sequence and when all warm up settings are enabled is shown.

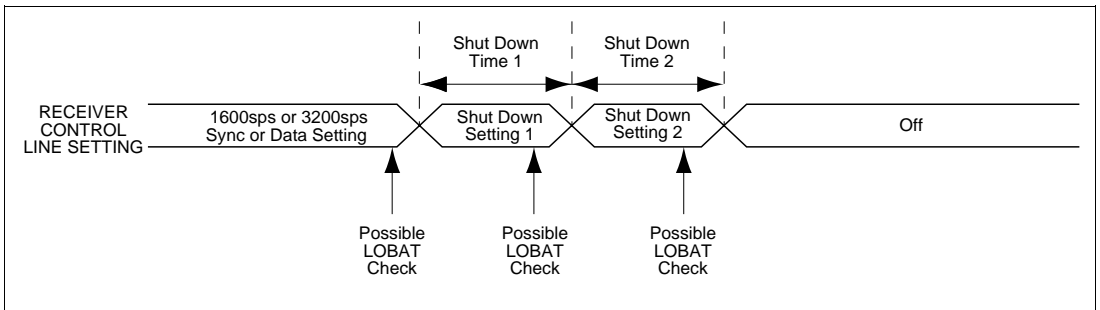


**Figure 14.10 Host Initiated Receiver Warm Up Sequence**

#### 4. Receiver Shut Down Sequence

The FLEX™ decoder II allows for up to 3 steps associated with shutting down the receiver. When the FLEX™ decoder II decides to turn off the receiver, the first shut down setting, if enabled, is applied to the receiver control lines for the corresponding shut down time. At the end of the last used shut down time, the “Off” setting is applied to the receiver control lines. If the first shut down setting is not enabled, the FLEX™ decoder II will transition directly from the current on setting to the “Off” setting. The receiver turn off sequence when all shut down settings are enabled is shown in figure 14.11.

If the receiver is on or being warmed up when the decoder is turned off (by clearing the ON bit in the Control Packet), the FLEX™ decoder II will execute the receiver shutdown sequence. If the FLEX™ decoder II is executing the shut down sequence when the FLEX™ decoder II is turned on (by setting the ON bit in the Control Packet), the FLEX™ decoder II will complete the shut down sequence before starting the warm up sequence.



**Figure 14.11 Receiver Shut Down Sequence**

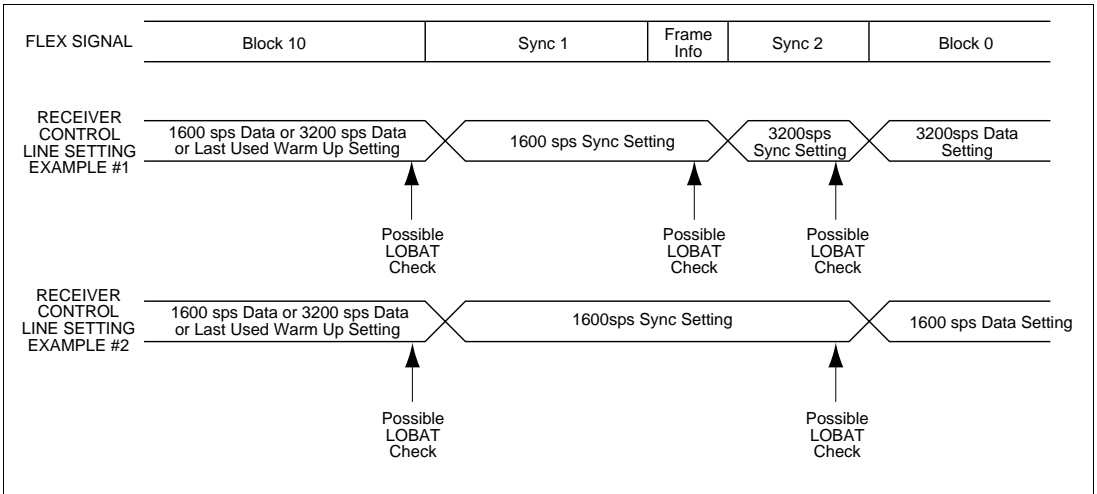
#### 5. Miscellaneous Receiver States

In addition to the warm up and shut down states, the FLEX™ decoder II has four other receiver states. When these settings are applied to the receiver control lines, the FLEX™ decoder II will be decoding the EXTS1 and EXTS0 input signals (or the equivalent internal signals when using the internal demodulator/data slicer). The timing of these signals and their duration depends on the data the FLEX™ decoder II decodes. The four settings are as follows:

- **1600sps Sync Setting:** This setting is applied when the FLEX™ decoder II is searching for a 1600 symbols per second signal.
- **3200sps Sync Setting:** This setting is applied when the FLEX™ decoder II is searching for a 3200 symbols per second signal.
- **1600sps Data Setting:** This setting is applied after the FLEX™ decoder II has found the C or  $\bar{C}$  sync word in a 1600 symbols per second frame.

- **3200sps Data Setting:** This setting is applied after the FLEX™ decoder II has found the C or  $\bar{C}$  sync word in a 3200 symbols per second frame.

Some examples of how these settings will be used in the FLEX™ decoder II are shown in figure 14.12.



**Figure 14.12 Examples of Receiver Control Transitions**

## 6. Low Battery Detection

The FLEX™ decoder II can be configured to poll the LOBAT input pin at the end of every receiver control setting. This check can be enabled or disabled for each receiver control setting. If the poll is enabled for a setting, the pin will be read just before the FLEX™ decoder II changes the receiver control lines from that setting to another setting. The FLEX™ decoder II will send a Status Packet whenever the value on two consecutive reads of the LOBAT pin yields different results.

### 14.5.2 Message Building

A simple message consists of an Address Packet followed by a Vector Packet indicating the word numbers of associated Message Packets. The tables below show a more complex example of receiving three Messages and two Block Information Word Packets in the first two blocks of a 2 phase 3200 bps, FLEX frame. Note that the messages shown may be portions of fragmented or group messages. Note further that in the case of a 6400 bps FLEX signal, there would be four phases: A, B, C and D, and in the case of a 1600 bps signal there would be only a single phase A.

Table 14.30 shows the block number, word number (WN) and word content of both phases A and C. Note contents of words not meant to be received by the host are left blank. Each phase begins with a block information word (WN 0), this is not sent to the host. The first message is in phase A

and has an address (WN 3), vector (WN 7) and three message words (WN9 - 11). The second message is also in phase A and has an address (WN 4), a vector (WN 8) and four message words (WN 12 - 15). The third message is in phase C and has a 2 word long address (WN 5 - 6) followed by a vector (WN 10) and three message words. Since the third message is sent on a long address, the first message word (WN 11) begins immediately after the vector. The vector indicates the location of the second and third message words (WN 14 - 15).

**Table 14.30 FLEX SIGNAL**

<b>BLOCK</b>	<b>Word Number</b>	<b>PHASE A</b>	<b>PHASE C</b>
0	0	BIW1	BIW1
	1		BIW
	3	ADDRESS 1	BIW
	4	ADDRESS 2	
	5		LONG ADDRESS 3 WORD 1
	6		LONG ADDRESS 3 WORD 2
	7	VECTOR 1	
1	8	VECTOR 2	
	9	MESSAGE 1,1	
	10	MESSAGE 1,2	VECTOR 3
	11	MESSAGE 1,3	MESSAGE 3,1
	12	MESSAGE 2,1	
	13	MESSAGE 2,2	
	14	MESSAGE 2,3	MESSAGE 3,2
	15	MESSAGE 2,4	MESSAGE 3,3

Table 14.31 shows the sequence of packets received by the host. The FLEX™ decoder II processes the FLEX signal one block at a time, and one phase at a time. Thus, the address and vector information in block 0 phase A is sent to the host in packets 1-3. Then information in block 0 phase C, two block information words and one long address, is sent to the host in packets 4-6. Packets 7 - 18 correspond to information in block 1, processed in phase A first and phase C second.



**Table 14.31 FLEX™ DECODER II PACKET SEQUENCE**

PACKET TYPE	PACKET	PHASE	WORD NUMBER	COMMENT
1st	ADDRESS	A	N.A. (7)	Address 1 has a vector located at WN 7
2nd	ADDRESS	A	N.A. (8)	Address 2 has a vector located at WN 8
3rd	VECTOR	A	7	Vector for Address 1: Message Words located at WN = 9 to 11, phase A
4th	BIW	C	N.A.	If BIWs enabled, then BIW packet sent
5th	BIW	C	N.A.	If BIWs enabled, then BIW packet sent
6th	LONG ADDRESS	C	N.A. (10)	Long Address 3 has a vector beginning in word 10 of phase C
7th	VECTOR	A	8	Vector for Address 2: Message Words located at WN = 12 to 15, phase A
8th	MESSAGE	A	9	Message information for Address 1
9th	MESSAGE	A	10	Message information for Address 1
10th	MESSAGE	A	11	Message information for Address 1
11th	MESSAGE	A	12	Message information for Address 2
12th	MESSAGE	A	13	Message information for Address 2
13th	MESSAGE	A	14	Message information for Address 2
14th	MESSAGE	A	15	Message information for Address 2
15th	VECTOR	C	10	Vector for Long Address 3: Message Words located at WN = 14 - 15, phase C
16th	MESSAGE	C	11	Second word of Long Vector is first message information word of Address 3
17th	MESSAGE	C	14	Message information for Address 3
18th	MESSAGE	C	15	Message information for Address 3

The first message is built by relating packets 1, 3, and 8-10. The second message is built by relating packets 2, 7 and 11 - 14. The third message is built by relating packets 6 and 15 - 18. Additionally, the host may process block information in packets 4 and 5 for time setting information.

### 14.5.3 Building a Fragmented Message

The longest message which will fit into a frame is 84 code words total of message data. Three alpha characters per word yields a maximum message of 252 characters in a frame assuming no other traffic. Messages longer than this value must be sent as several fragments.

Additional fragments can be expected when the “continue bit” in the 1st Message Word is set. This causes the pager to examine every following frame for an additional fragment until the last fragment with the continue bit reset is found. The only requirement relating to the placement in time of the remaining fragments is that no more than 32 frames (1 minute) or 128 frames (4 minutes) as indicated by the service provider may pass between fragment receptions.

Each fragment contains a check sum character to detect errors in the fragment, a fragment number 0, 1, or 2 to detect missing fragments, a message number to identify which message the fragment is a part, and the continue bit which either indicates that more fragments are in queue or that the last fragment has been received.

The following describes the sequence of events between the Host and the FLEX™ decoder II required to handle a fragmented message:

- The host will receive a vector indicating one of the following types:

$V_2$	$V_1$	$V_0$	Type
0	0	0	Secure
1	0	1	Alphanumeric
1	1	0	Hex / Binary

- The FLEX™ decoder II will increment the all frame mode counter inside the FLEX™ decoder II and begin to decode all of the following frames.
- The host will receive the Message Packet(s) contained within that frame followed by a Status Packet. The host must decide based on the Message Packet to return to normal decoding operation. If the message is indicated as fragmented by the Message Continued Flag “C” being set in the Message Packet then the host does not decrement the all frame mode counter at this time. The host decrements the counter if the Message Continued Flag “C” is clear by writing the All Frame Mode Packet to the FLEX™ decoder II with the “DAF” bit = 1. If no other fragments, temporary addresses are pending and the FAF bit is clear in the All Frame Mode Register, then the FLEX™ decoder II returns to normal operation.
- The FLEX™ decoder II continues to decode all of the frames and passes any address information, vector information and message information to the host followed by a status packet indicating the end of the frame. If the message is indicated as fragmented by the Message Continued Flag “C” in the Message Packet then the host remains in the receive mode expecting more information from the FLEX™ decoder II.
- After the host receives the second and subsequent fragment with the Message Continued Flag “C” = 1, it should decrement the all frame mode counter by sending an All Frame Mode Packet to the FLEX™ decoder II with the “DAF” bit = 1. Alternatively, the host may choose to decrement the counter at the end of the entire message by decrementing the counter once for each fragment received.
- When the host receives a Message Packet with the Message Continued Flag “C” = 0, it will send two All Frame Mode Packets to the FLEX™ decoder II with the “DAF” bit = 1. The two

packets decrement the count for the first fragment and the last fragment. This decrements the all frame counter to zero, if no other fragmented messages, temporary addresses are pending and the FAF bit is clear in the All Frame Mode Register, the FLEX™ decoder II returns to normal operation.

- The above process must be repeated for each occurrence of a fragmented message. The host must keep track of the number of fragmented messages being decoded and insure the all frame mode counter decrements after each fragment or after each fragmented message.

**Table 14.32 Alphanumeric Message without fragmentation**

PACKET	PACKET TYPE	PHASE	All Frame Counter	COMMENT
1st	ADDRESS 1	A	0	Address 1 is received
2nd	VECTOR 1	A	1	Vector = Alphanumeric Type
3rd	MESSAGE	A	1	Message Word received "C" bit = 0, No more fragments are expected.
4th	Variable*		0	Host writes All Frame Mode Packet to the FLEX™ decoder II with the "DAF" bit = 1

Note: \* Host Initiated Packet. The FLEX™ decoder II returns a packet according to 14.4, Decoder-to-Host Packet Descriptions.

**Table 14.33 Alphanumeric Message with fragmentation**

PACKET	PACKET TYPE	PHASE	All Frame Counter	COMMENT
1st	ADDRESS 1	A	0	Address 1 is received
2nd	VECTOR 1	A	1	Vector = Alphanumeric Type
3rd	MESSAGE	A	1	Message Word received "C" bit = 1, Message is fragmented, more expected
4th	STATUS		1	End of Frame Indication (EOF = 1)
5th	ADDRESS 1	B	1	Address 1 is received
6th	VECTOR 1	B	2	Vector = Alphanumeric Type
7th	MESSAGE	B	2	Message Word received "C" bit = 1, Message is fragmented, more expected.
8th	Variable*		1	Host writes All Frame Mode Packet to the FLEX™ decoder II with the "DAF" bit = 1
9th	STATUS		1	End of Frame Indication (EOF = 1)
10th	ADDRESS 1	A	1	Address 1 is received
11th	VECTOR 1	A	2	Vector = Alphanumeric type
12th	MESSAGE	A	2	Message Word received "C" bit = 0, No more fragments are expected.
13th	Variable*		1	Host writes All Frame Mode Packet to the FLEX™ decoder II with the "DAF" bit = 1
14th	Variable*		0	Host writes All Frame Mode Packet to the FLEX™ decoder II with the "DAF" bit = 1

Note: \* Host Initiated Packet. The FLEX™ decoder II returns a packet according to 14.4, Decoder-to-Host Packet Descriptions.

#### 14.5.4 Operation of a Temporary Address

##### 1. Group Messaging

The FLEX protocol allows for a dynamic group call for the purpose of sending a common message to a group of paging devices. The dynamic group call approach assigns a "Temporary Address" using the personal address and the short instruction vector.

The FLEX protocol specifies sixteen addresses for the dynamic group call which may be temporarily activated in a future frame (If the frame or one of the frames designated is equal to the present frame the host is to interpret this as the next occurrence of this frame 4 minutes in the future.) The temporary address is valid for one message starting in the specified frame(s) and remaining valid throughout the following frames to the completion of the message. If the message is not found in the specified frame(s) the host must disable the assigned temporary address.

The following describes the sequence of events between the Host and the FLEX™ decoder II required to handle a temporary address:

- Following an Address Packet, the host will receive a Vector Packet with  $V_2 V_1 V_0 = 001$  and  $i_2 i_1 i_0 = 000$  or  $010$  (a Short Instruction Vector indicating a temporary address has been assigned to this pager). The system may send either  $i_2 i_1 i_0 = 000$  or  $i_2 i_1 i_0 = 010$  or both when assigning a temporary address. The vector packet with  $i_2 i_1 i_0 = 000$  will indicate which temporary address is assigned and the frame in which the temporary address is expected. The vector packet with  $i_2 i_1 i_0 = 010$  will indicate which temporary address is assigned, the MSb of the expected frame (essentially indicating 64 frames in which to look for the temporary address), and a message sequence number. When the vector packet with  $i_2 i_1 i_0 = 010$  is received on a long address, the specific assign frame is included in the message word sent after the vector.
- The FLEX™ decoder II will increment the corresponding temporary address counter for each temporary address assignment vector received and begin to decode all of the following frames. Note that this implies a single dynamic group assignment that is implemented by sending two short instructions (one for each temporary address assignment mode of the short instruction vector) will cause the corresponding temporary address counter to increment twice.
- The FLEX™ decoder II continues to decode all of the frames and passes any address information, vector information and message information to the host followed by a status packet indicating the end of each frame and the current frame number.

There are several scenarios which may occur with temporary addresses.

1. The temporary address is not found in any of the assigned frames and therefore the host must terminate the temporary address mode by sending an All Frame Mode Packet to the FLEX™ decoder II with the “DTA” bit of the particular temporary address set (if both temporary address assignment packets were used to assign the temporary address, the “DTA” bit must be set twice to disable the temporary address).
2. The temporary address is found in the frame it was assigned and was not a fragmented message. Again, the host must terminate the temporary address mode by sending an All Frame Mode Packet to the FLEX™ decoder II with the “DTA” bit of the particular temporary address set (if both temporary address assignment packets were used to assign the temporary address, the “DTA” bit must be set twice to disable the temporary address).
3. The temporary address is found in the assigned frame and it is a fragmented message. In this case, the host must follow the rules for Operation of a Fragmented Message and determine the proper time to stop the all frame mode operation. In this case, the host must write to the “DAF” bit with a “1” and the appropriate “DTA” bit with a “1” in the All Frame Mode Register in order to terminate both the fragmented message and the temporary address (if both temporary address assignment packets were used to assign the temporary address, the “DTA” bit must be set twice to disable the temporary address).

- The above operation is repeated for every temporary address.

### 14.5.5 Using the Receiver Shutdown Packet

The contents of this section apply to the FLEX Roaming Decoder. They are not applicable to the FLEX Non-Roaming Decoder.

#### 1. Calculating Time Left

The receiver shutdown packet gives timing information to the host. Two times are of particular interest when implementing a roaming algorithm.

- **TimeToWarmUpStart.** Defined as the amount of time there is before the receiver will start to warm up (i.e. transition from the off state to the first warm up state).
- **TimeToTasksDisabled.** Defined as the amount of time the host has to complete any host initiated tasks (e.g. by setting SND or SAS in the roaming control packet).

The formula's for calculating these times depend on whether the FLEX™ decoder II is in synchronous mode or asynchronous mode.

#### SYNCHRONOUS MODE:

$$\text{TimeToWarmUpStart} \geq (\text{TNF} \cdot 80\text{ms}) + (\text{SkippedFrames} \cdot 1874.375\text{ms}) + \text{ReceiverOffTime} - 167.5\text{ms}$$

$$\text{TimeToTasksDisabled} \geq (\text{TNF} \cdot 80\text{ms}) + (\text{SkippedFrames} \cdot 1874.375\text{ms}) - 247.5\text{ms}$$

#### ASYNCHRONOUS MODE:

$$\text{TimeToWarmUpStart} \geq ((\text{TNF} - 2) \cdot 80\text{ms}) + \text{ReceiverOffTime}$$

$$\text{TimeToTasksDisabled} \geq ((\text{TNF} - 3) \cdot 80 \text{ ms})$$

Where,

- |                  |   |
|------------------|---|
| TNF:             | Time to Next Frame. Value from the receiver shutdown packet.  |
| SkippedFrames:   | The number of frames that won't be decoded. This can be calculated from the Current Frame (CF) and Next Needed Frame (NAF) fields in the receiver shutdown packet (e.g. If CF is 10 and NAF is 12, then SkippedFrames is 1) |
| ReceiverOffTime: | The time programmed in the receiver off setting packet.   |

## 2. Calculating How Long Tasks Take

Since the TimeToTaskDisabled discussed in the previous section limits how much the host can do while the FLEX™ decoder II is battery saving, it is necessary for the host to know how long it can take the FLEX™ decoder II to perform a task.

The formulas below calculate how long the two types of host initiated tasks take to complete as measured from the last SPI clock of the packet that initiates the task to the time the receiver shutdown sequence starts. Note that the receiver shutdown sequence must start before tasks are disabled.

The following formula calculates how long it will take to complete a Noise Detect started by setting the SND bit in the roaming control packet. This formula assumes that (1) the noise detect was performed while in synchronous mode or (2) the noise detect was performed in asynchronous mode and did not find FLEX signal or (3) the noise detect found FLEX signal but the DAS bit of the roaming control packet was set.

$$\text{TimeToPerformNoiseDetect} \leq \text{TotalWarmUpTime} + 82\text{ms}$$

Where,

**TotalWarmUpTime:** The sum of the times programmed for the used warm up steps plus the time programmed for the 3200sps Sync Setting in the receiver control configuration packets.

The following formula calculates how long it will take to complete an A-word search initiated by setting the SAS bit in the roaming control packet. This formula assumes that the A-word search failed to find roaming FLEX channel.

$$\text{TimeToPerformAwordSearch} \leq \text{TotalWarmUpTime} + \text{AST} + 47\text{ms}$$

Where,

**TotalWarmUpTime:** The sum of the times programmed for the used warm up steps plus the time programmed for the 3200sps Sync Setting in the receiver control configuration packets.

**AST:** The value configured using the timing control packet.

The following formula calculates how long it will take to complete a Noise Detect/A-word search combination. This can occur when the noise detect is performed while in asynchronous mode, the noise detect finds FLEX signal, and the DAS bit of the roaming control packet is not set.

$$\text{TimeToPerformBoth} \leq \text{TotalWarmUpTime} + \text{AST} + 127\text{ms}$$

Where,

TotalWarmUpTime: The sum of the times programmed for the used warm up steps plus the time programmed for the 3200sps Sync Setting in the receiver control configuration packets.

AST: The value configured using the timing control packet.



## 14.6 Timing Diagrams (Reference Data)

The following diagrams show the timing in a standalone FLEX™ Decoder II IC. They do not apply to this LSI, and should be used only for reference.

### 14.6.1 SPI Timing

The following diagram and table describe the timing specifications of the SPI interface.

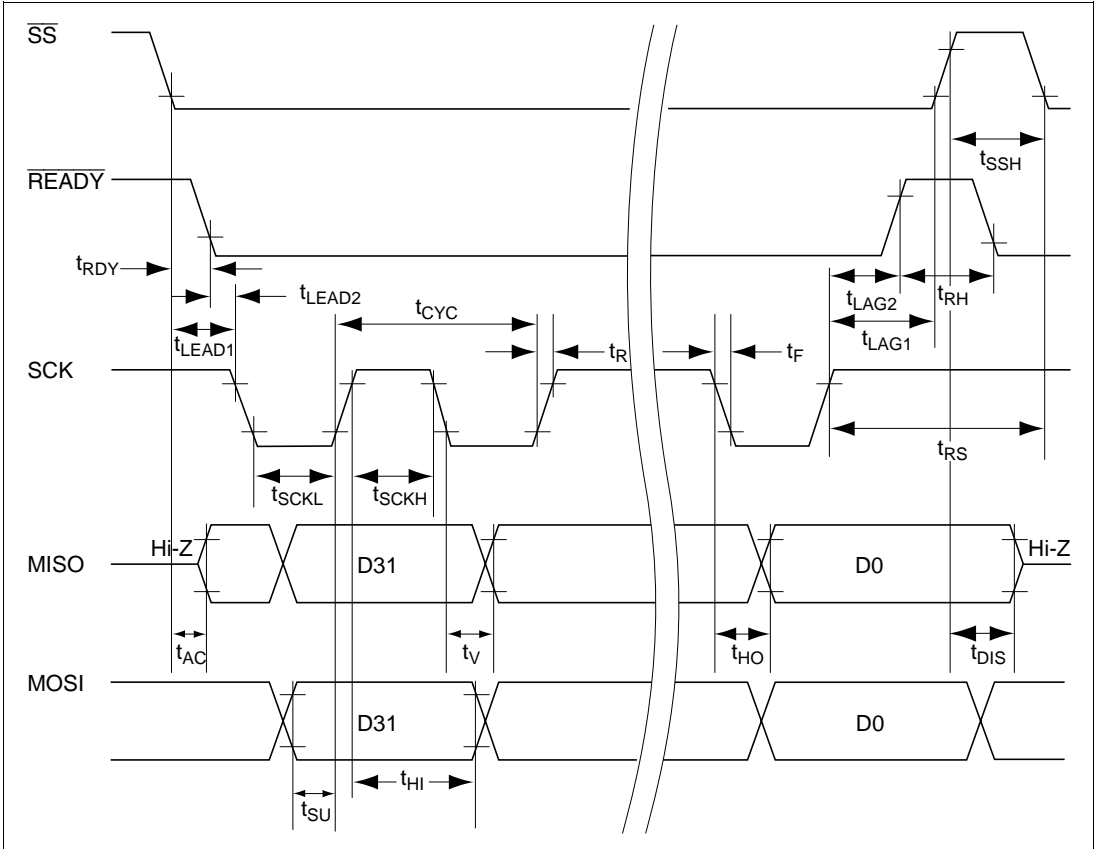


Figure 14.13 SPI Timing

**Table 14.34 SPI Timing ( $V_{CC} = 2.7\text{ V to }3.6\text{ V}$ ,  $T_A = -20^\circ\text{C to }75^\circ\text{C}$ )**

Characteristic	Conditions	Symbol	Min* <sup>1</sup>	Max* <sup>1</sup>	Unit
Operating Frequency		$f_{OP}$	dc	1	MHz
Cycle Time		$t_{CYC}$	1000		ns
Select Lead Time		$t_{LEAD1}$	200		ns
De-select Lag Time		$t_{LAG1}$	200		ns
Select-to-Ready Time	previous packet did not program an address word* <sup>2</sup> $C_L = 50\text{pf}$	$t_{RDY}$		80	$\mu\text{s}$
Select-to-Ready Time	previous packet programmed an address word* <sup>2</sup> $C_L = 50\text{pf}$	$t_{RDY}$		420	$\mu\text{s}$
Re-select Time	previous packet was a checksum/special packet* <sup>3</sup> $C_L = 50\text{pf}$	$t_{RS}$	30		$\mu\text{s}$
Ready High Time		$t_{RH}$	50		$\mu\text{s}$
Ready Lead Time		$t_{LEAD2}$	200		ns
Not Ready Lag Time	$C_L = 50\text{pf}$	$t_{LAG2}$		200	ns
MOSI Data Setup Time		$t_{SU}$	200		ns
MOSI Data Hold Time		$t_{HI}$	200		ns
MISO Access Time	$C_L = 50\text{pf}$	$t_{AC}$	0	200	ns
MISO Disable Time		$t_{DIS}$		300	ns
MISO Data Valid Time	$C_L = 50\text{pf}$	$t_V$		200	ns
MISO Data Hold Time		$t_{HO}$	0		ns
SS High Time		$t_{SSH}$	200		ns
SCK High Time		$t_{SCKH}$	300		ns
SCK Low Time		$t_{SCKL}$	300		ns
SCK Rise Time	20% to 70% $V_{DD}$	$t_R$		1	$\mu\text{s}$
SCK Fall Time	20% to 70% $V_{DD}$	$t_F$		1	$\mu\text{s}$

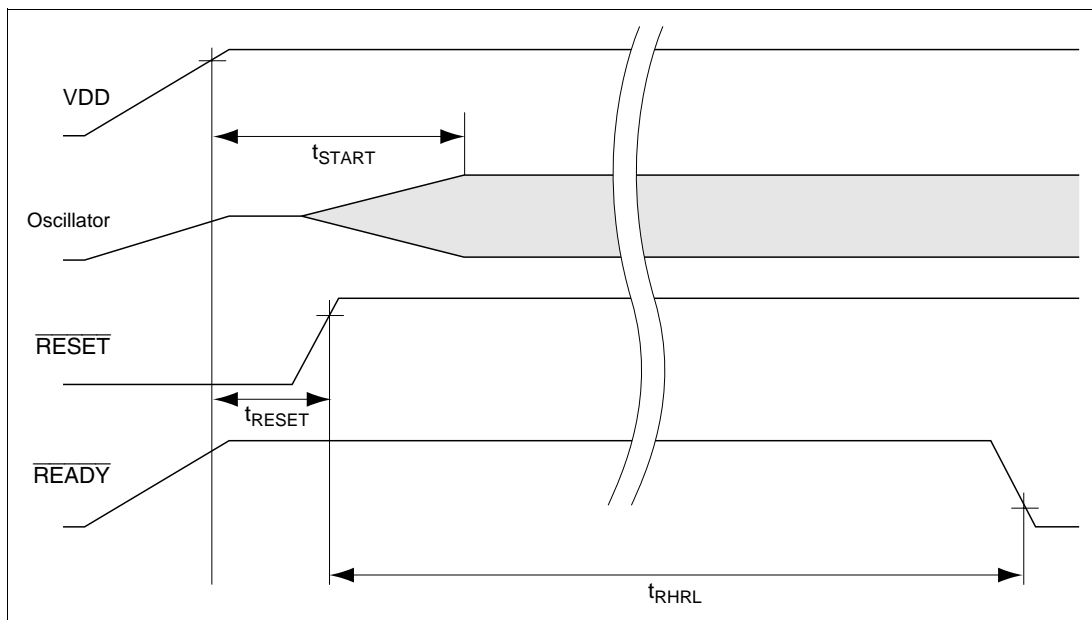
Notes: \*1 The specifications given in this data sheet indicate the minimum performance level of all FLEX™ decoders regardless of manufacturer. Individual manufacturers may have better performance than indicated.

\*2 When the host re-programs an address word with a Host-to-Decoder packet ID > 127 (decimal), there may be an added delay before the FLEX™ decoder II is ready for another packet.

\*3 When the host sends a checksum packet (ID is 00) or a special packet (ID is 1C through 1F hex) the  $t_{RS}$  specification applies, otherwise the timing specifications for  $t_{LAG1}$  and  $t_{SSH}$  govern the re-select timing.

## 14.6.2 Start-up Timing

The following diagram and table describe the timing specifications of the FLEX™ decoder II when power is applied.



**Figure 14.14 Start-up Timing**

**Table 14.35 Start-up Timing ( $V_{CC} = 2.7\text{ V to }3.6\text{ V}$ ,  $T_A = -20^\circ\text{C to }75^\circ\text{C}$ )**

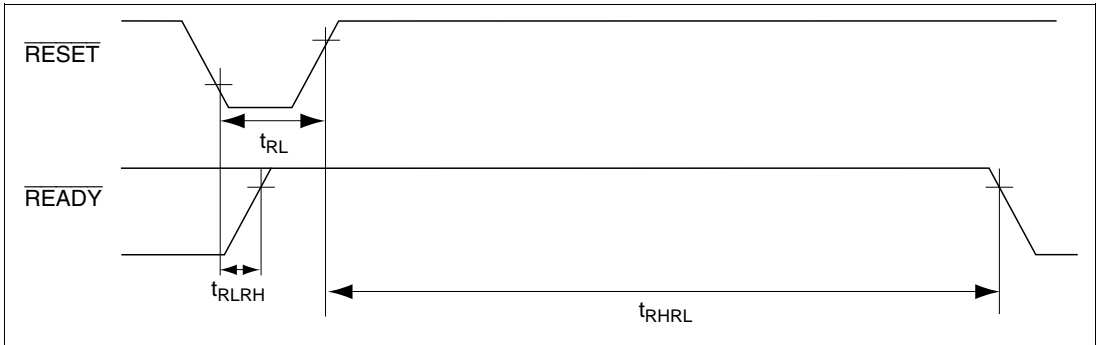
Characteristic	Conditions	Symbol	Min* <sup>1</sup>	Max * <sup>1</sup>	Unit
Oscillator Start-up Time		$t_{START}$		5	sec
RESET Hold Time		$t_{RESET}$	200		ns
RESET High to READY Low		$t_{RHRL}$	76,800	76,800	$T^{*2}$

Notes: \*<sup>1</sup> The specifications given in this data sheet indicate the minimum performance level of all manufacturers of the FLEX™ decoder II. Individual manufacturers may have better performance than indicated.

\*<sup>2</sup> T is one period of the  $\phi_{DEC}$  clock source. Note that from power-up, the oscillator start-up time can impact the availability and period of clock strobes. This can affect the actual RESET high to READY low timing.

### 14.6.3 Reset Timing

The following diagram and table describe the timing specifications of the FLEX™ decoder II when it is reset.



**Figure 14.15 Reset Timing**

**Table 14.36 Reset Timing ( $V_{\text{CC}} = 2.7 \text{ V to } 3.6 \text{ V}$ ,  $T_{\text{A}} = -20^{\circ}\text{C to } 75^{\circ}\text{C}$ )**

Characteristic	Conditions	Symbol	Min <sup>*1</sup>	Max <sup>*1</sup>	Unit
$\overline{\text{RESET}}$ Pulse Width		$t_{\text{RL}}$	200	–	ns
$\overline{\text{RESET}}$ Low to $\overline{\text{READY}}$ High		$t_{\text{RLRH}}$	–	200	ns
$\overline{\text{RESET}}$ High to $\overline{\text{READY}}$ Low		$t_{\text{RHRL}}$	76,800	76,800	T <sup>*2</sup>

Notes: \*1 The specifications given in this data sheet indicate the minimum performance level of all manufacturers of the FLEX™ decoder II. Individual manufacturers may have better performance than indicated.

\*2 T is one period of the  $\phi_{\text{DEC}}$  clock source.

# Section 15 A/D Converter

## 15.1 Overview

The LSI incorporates a successive approximation type 10-bit A/D converter that allows up to eight analog input channels to be selected.

### 15.1.1 Features

A/D converter features are listed below

- 10-bit resolution
- Eight input channels
- Settable analog conversion voltage range
  - Conversion of analog voltages with the reference voltage pin ( $V_{ref}$ ) as the analog reference voltage
- High-speed conversion
  - Minimum conversion time: 9.9  $\mu$ s per channel (at 13 MHz operation)
- Choice of single mode or scan mode
  - Single mode: Single-channel A/D conversion
  - Scan mode: Continuous A/D conversion on 1 to 4 channels
- Four data registers
  - Conversion results are held in a 16-bit data register for each channel
- Sample and hold function
- Three kinds of conversion start
  - Choice of software or timer conversion start trigger (TPU or 8-bit timer), or  $\overline{ADTRG}$  pin
- A/D conversion end interrupt generation
  - A/D conversion end interrupt (ADI) request can be generated at the end of A/D conversion
- Module stop mode can be set
  - As the initial setting, A/D converter operation is halted. Register access is enabled by exiting module stop mode.

## 15.1.2 Block Diagram

Figure 15.1 shows a block diagram of the A/D converter.

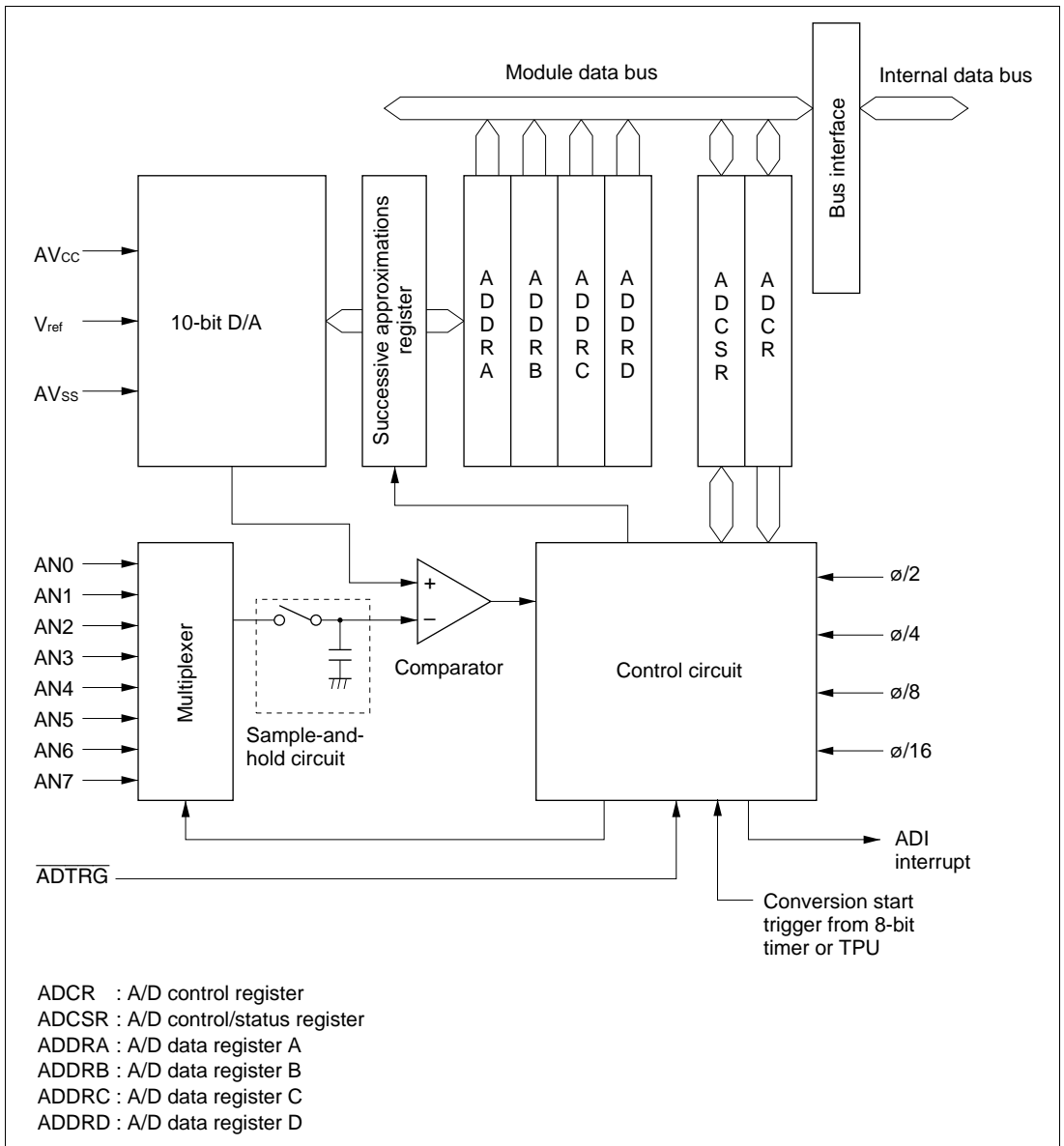


Figure 15.1 Block Diagram of A/D Converter

### 15.1.3 Pin Configuration

Table 15.1 summarizes the input pins used by the A/D converter.

The AVcc and AVss pins are the power supply pins for the analog block in the A/D converter. The Vref pin is the A/D conversion reference voltage pin.

The eight analog input pins are divided into two groups: group 0 (AN0 to AN3), and group 1 (AN4 to AN7).

**Table 15.1 A/D Converter Pins**

<b>Pin Name</b>	<b>Symbol</b>	<b>I/O</b>	<b>Function</b>
Analog power supply pin	AVcc	Input	Analog block power supply
Analog ground pin	AVss	Input	Analog block ground and reference voltage
Reference voltage pin	Vref	Input	A/D conversion reference voltage
Analog input pin 0	AN0	Input	Group 0 analog inputs
Analog input pin 1	AN1	Input	
Analog input pin 2	AN2	Input	
Analog input pin 3	AN3	Input	
Analog input pin 4	AN4	Input	Group 1 analog inputs
Analog input pin 5	AN5	Input	
Analog input pin 6	AN6	Input	
Analog input pin 7	AN7	Input	
A/D external trigger input pin	$\overline{\text{ADTRG}}$	Input	External trigger input for starting A/D conversion

## 15.1.4 Register Configuration

Table 15.2 summarizes the registers of the A/D converter.

**Table 15.2 A/D Converter Registers**

<b>Name</b>	<b>Abbreviation</b>	<b>R/W</b>	<b>Initial Value</b>	<b>Address*<sup>1</sup></b>
A/D data register AH	ADDRAH	R	H'00	H'FF90
A/D data register AL	ADDRAL	R	H'00	H'FF91
A/D data register BH	ADDRBH	R	H'00	H'FF92
A/D data register BL	ADDRBL	R	H'00	H'FF93
A/D data register CH	ADDRCH	R	H'00	H'FF94
A/D data register CL	ADDRCL	R	H'00	H'FF95
A/D data register DH	ADDRDH	R	H'00	H'FF96
A/D data register DL	ADDRDL	R	H'00	H'FF97
A/D control/status register	ADCSR	R/(W)* <sup>2</sup>	H'00	H'FF98
A/D control register	ADCR	R/W	H'33	H'FF99
Module stop control register A	MSTPCRA	R/W	H'3F	H'FDE8

Notes: \*1 Lower 16 bits of the address.

\*2 Bit 7 can only be written with 0 for flag clearing.



## 15.2 Register Descriptions

### 15.2.1 A/D Data Registers A to D (ADDRA to ADDR D)

Bit	:	15	14	13	12	11	10	9	8	7	6	5	4	3	2	1	0
		AD9	AD8	AD7	AD6	AD5	AD4	AD3	AD2	AD1	AD0	—	—	—	—	—	—
Initial value	:	0	0	0	0	0	0	0	0	0	0	0	0	0	0	0	0
R/W	:	R	R	R	R	R	R	R	R	R	R	R	R	R	R	R	R

There are four 16-bit read-only ADDR registers, ADDRA to ADDR D, used to store the results of A/D conversion.

The 10-bit data resulting from A/D conversion is transferred to the ADDR register for the selected channel and stored there. The upper 8 bits of the converted data are transferred to the upper byte (bits 15 to 8) of ADDR, and the lower 2 bits are transferred to the lower byte (bits 7 and 6) and stored. Bits 5 to 0 are always read as 0.

The correspondence between the analog input channels and ADDR registers is shown in table 15.3.

ADDR can always be read by the CPU. The upper byte can be read directly, but for the lower byte, data transfer is performed via a temporary register (TEMP). For details, see section 15.3, Interface to Bus Master.

The ADDR registers are initialized to H'0000 by a reset, and in standby mode or module stop mode.

**Table 15.3 Analog Input Channels and Corresponding ADDR Registers**

Analog Input Channel		A/D Data Register
Group 0	Group 1	
AN0	AN4	ADDRA
AN1	AN5	ADDRB
AN2	AN6	ADDRC
AN3	AN7	ADDRD

### 15.2.2 A/D Control/Status Register (ADCSR)

Bit	:	7	6	5	4	3	2	1	0
		ADF	ADIE	ADST	SCAN	—	CH2	CH1	CH0
Initial value	:	0	0	0	0	0	0	0	0
R/W	:	R/(W)*	R/W	R/W	R/W	R/W	R/W	R/W	R/W

Note: \* Only 0 can be written to bit 7, to clear this flag.

ADCSR is an 8-bit readable/writable register that controls A/D conversion operations.

ADCSR is initialized to H'00 by a reset, and in hardware standby mode or module stop mode.

**Bit 7—A/D End Flag (ADF):** Status flag that indicates the end of A/D conversion.

#### Bit 7

ADF	Description
0	[Clearing conditions] (Initial value) <ul style="list-style-type: none"> <li>When 0 is written to the ADF flag after reading ADF = 1</li> <li>When the DTC is activated by an ADI interrupt and ADDR is read</li> </ul>
1	[Setting conditions] <ul style="list-style-type: none"> <li>Single mode: When A/D conversion ends</li> <li>Scan mode: When A/D conversion ends on all specified channels</li> </ul>

**Bit 6—A/D Interrupt Enable (ADIE):** Selects enabling or disabling of interrupt (ADI) requests at the end of A/D conversion.

#### Bit 6

ADIE	Description
0	A/D conversion end interrupt (ADI) request disabled (Initial value)
1	A/D conversion end interrupt (ADI) request enabled

**Bit 5—A/D Start (ADST):** Selects starting or stopping on A/D conversion. Holds a value of 1 during A/D conversion.

The ADST bit can be set to 1 by software, a timer conversion start trigger, or the A/D external trigger input pin ( $\overline{\text{ADTRG}}$ ).

#### Bit 5

ADST	Description
0	• A/D conversion stopped (Initial value)
1	• Single mode: A/D conversion is started. Cleared to 0 automatically when conversion on the specified channel ends • Scan mode: A/D conversion is started. Conversion continues sequentially on the selected channels until ADST is cleared to 0 by software, a reset, or a transition to standby mode or module stop mode.

**Bit 4—Scan Mode (SCAN):** Selects single mode or scan mode as the A/D conversion operating mode. See section 15.4, Operation, for single mode and scan mode operation. Only set the SCAN bit while conversion is stopped.

#### Bit 4

SCAN	Description
0	Single mode (Initial value)
1	Scan mode

**Bit 3—Reserved:** 0 should be written to this bit.

**Bits 2 to 0—Channel Select 2 to 0 (CH2 to CH0):** Together with the SCAN bit, these bits select the analog input channels.

Only set the input channel while conversion is stopped (ADST = 0).

Group Selection	Channel Selection		Description	
	CH1	CH0	Single Mode (SCAN = 0)	Scan Mode (SCAN = 1)
0	0	0	AN0 (Initial value)	AN0
		1	AN1	AN0, AN1
	1	0	AN2	AN0 to AN2
		1	AN3	AN0 to AN3
1	0	0	AN4	AN4
		1	AN5	AN4, AN5
	1	0	AN6	AN4 to AN6
		1	AN7	AN4 to AN7

### 15.2.3 A/D Control Register (ADCR)

Bit	:	7	6	5	4	3	2	1	0
		TRGS1	TRGS0	—	—	CKS1	CKS0	—	—
Initial value	:	0	0	1	1	0	0	1	1
R/W	:	R/W	R/W	—	—	R/W	R/W	—	—

ADCR is an 8-bit readable/writable register that enables or disables external triggering of A/D conversion operations and sets the A/D conversion time.

ADCR is initialized to H'33 by a reset, and in standby mode or module stop mode.

**Bits 7 and 6—Timer Trigger Select 1 and 0 (TRGS1, TRGS0):** Select enabling or disabling of the start of A/D conversion by a trigger signal. Only set bits TRGS1 and TRGS0 while conversion is stopped (ADST = 0).

Bit 7	Bit 6	Description
TRGS1	TRGS0	
0	0	A/D conversion start by software is enabled (Initial value)
	1	A/D conversion start by TPU conversion start trigger is enabled
1	0	A/D conversion start by 8-bit timer conversion start trigger is enabled
	1	A/D conversion start by external trigger pin ( $\overline{\text{ADTRG}}$ ) is enabled

**Bits 5, 4, 1, and 0—Reserved:** These bits cannot be modified and are always read as 1.

**Bits 3 and 2—Clock Select 1 and 0 (CKS1, CKS0):** These bits select the A/D conversion time. The conversion time should be changed only when ADST = 0. The conversion time setting should be less than or equal to the conversion times shown in section 20.2.4, A/D Conversion Characteristics.

Bit 3	Bit 2	Description
CKS1	CKS0	
0	0	Conversion time = 530 states (max.) (Initial value)
	1	Conversion time = 260 states (max.)
1	0	Conversion time = 134 states (max.)
	1	Conversion time = 68 states (max.)

### 15.2.4 Module Stop Control Register A (MSTPCRA)

Bit	:	7	6	5	4	3	2	1	0
		MSTPA7	MSTPA6	MSTPA5	MSTPA4	MSTPA3	MSTPA2	MSTPA1	MSTPA0
Initial value	:	0	0	1	1	1	1	1	1
R/W	:	R/W	R/W	R/W	R/W	R/W	R/W	R/W	R/W

MSTPCRA is an 8-bit readable/writable register that performs module stop mode control.

When the MSTPA1 bit in MSTPCR is set to 1, A/D converter operation stops at the end of the bus cycle and a transition is made to module stop mode. Registers cannot be read or written to in module stop mode. For details, see section 19.5, Module Stop Mode.

MSTPCRA is initialized to H'3F by a reset and in hardware standby mode. It is not initialized in software standby mode.

**Bit 1—Module Stop (MSTPA1):** Specifies the A/D converter module stop mode.

Bit 1	Description
MSTPA1	
0	A/D converter module stop mode cleared
1	A/D converter module stop mode set (Initial value)

## 15.3 Interface to Bus Master

ADDRA to ADDR4 are 16-bit registers, and the data bus to the bus master is 8 bits wide. Therefore, in accesses by the bus master, the upper byte is accessed directly, but the lower byte is accessed via a temporary register (TEMP).

A data read from ADDR is performed as follows. When the upper byte is read, the upper byte value is transferred to the CPU and the lower byte value is transferred to TEMP. Next, when the lower byte is read, the TEMP contents are transferred to the CPU.

When reading ADDR, always read the upper byte before the lower byte. It is possible to read only the upper byte, but if only the lower byte is read, incorrect data may be obtained.

Figure 15.2 shows the data flow for ADDR access.

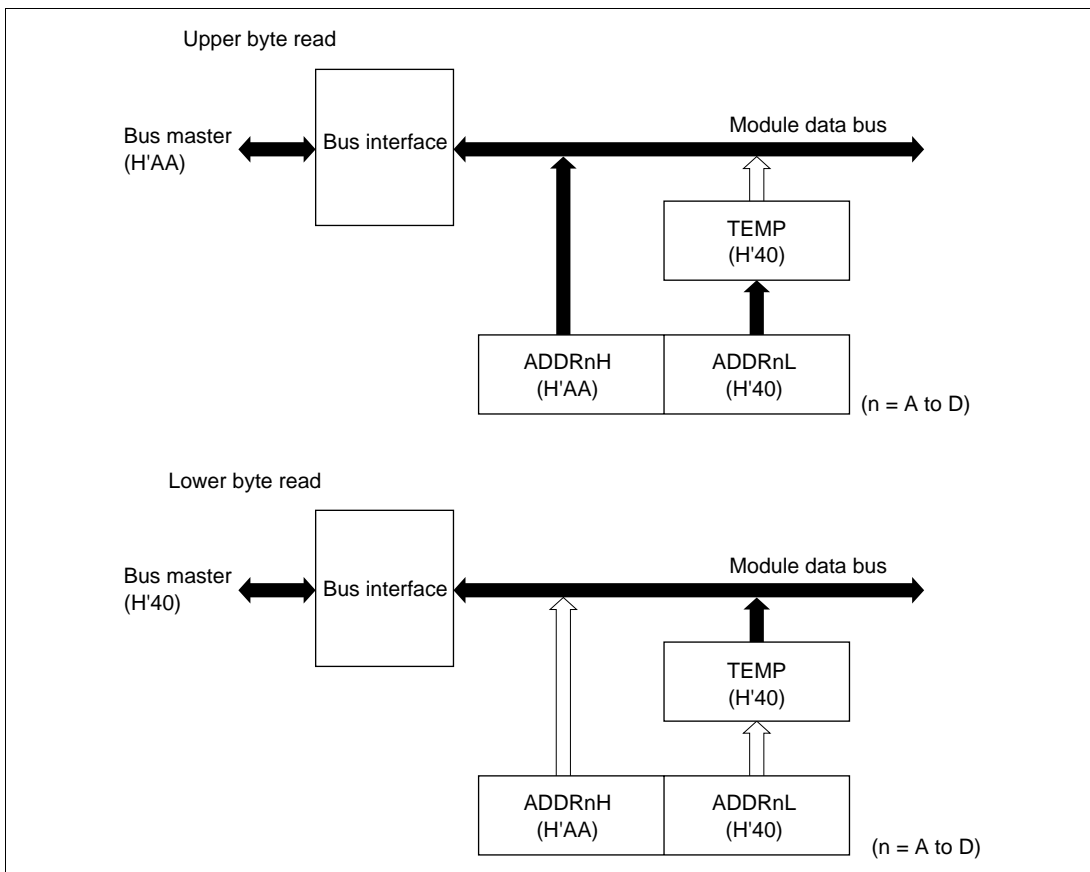


Figure 15.2 ADDR Access Operation (Reading H'AA40)

## 15.4 Operation

The A/D converter operates by successive approximation with 10-bit resolution. It has two operating modes: single mode and scan mode.

### 15.4.1 Single Mode (SCAN = 0)

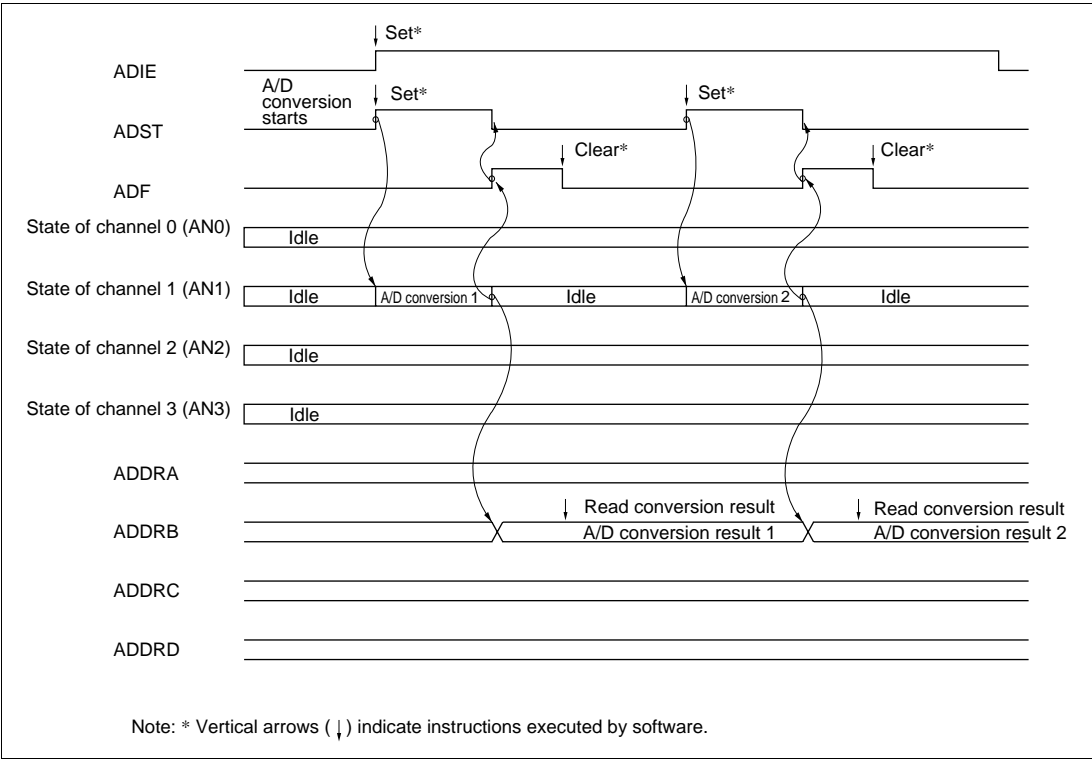
Single mode is selected when A/D conversion is to be performed on a single channel only. A/D conversion is started when the ADST bit is set to 1, according to the software or external trigger input. The ADST bit remains set to 1 during A/D conversion, and is automatically cleared to 0 when conversion ends.

On completion of conversion, the ADF flag is set to 1. If the ADIE bit is set to 1 at this time, an ADI interrupt request is generated. The ADF flag is cleared by writing 0 after reading ADCSR.

When the operating mode or analog input channel must be changed during analog conversion, to prevent incorrect operation, first clear the ADST bit to 0 in ADCSR to halt A/D conversion. After making the necessary changes, set the ADST bit to 1 to start A/D conversion again. The ADST bit can be set at the same time as the operating mode or input channel is changed.

Typical operations when channel 1 (AN1) is selected in single mode are described next. Figure 15.3 shows a timing diagram for this example.

- [1] Single mode is selected (SCAN = 0), input channel AN1 is selected (CH2 = 0, CH1 = 0, CH0 = 1), the A/D interrupt is enabled (ADIE = 1), and A/D conversion is started (ADST = 1).
- [2] When A/D conversion is completed, the result is transferred to ADDR0. At the same time the ADF flag is set to 1, the ADST bit is cleared to 0, and the A/D converter becomes idle.
- [3] Since ADF = 1 and ADIE = 1, an ADI interrupt is requested.
- [4] The A/D interrupt handling routine starts.
- [5] The routine reads ADCSR, then writes 0 to the ADF flag.
- [6] The routine reads and processes the conversion result (ADDR0).
- [7] Execution of the A/D interrupt handling routine ends. After that, if the ADST bit is set to 1, A/D conversion starts again and steps [2] to [7] are repeated.



**Figure 15.3 Example of A/D Converter Operation (Single Mode, Channel 1 Selected)**



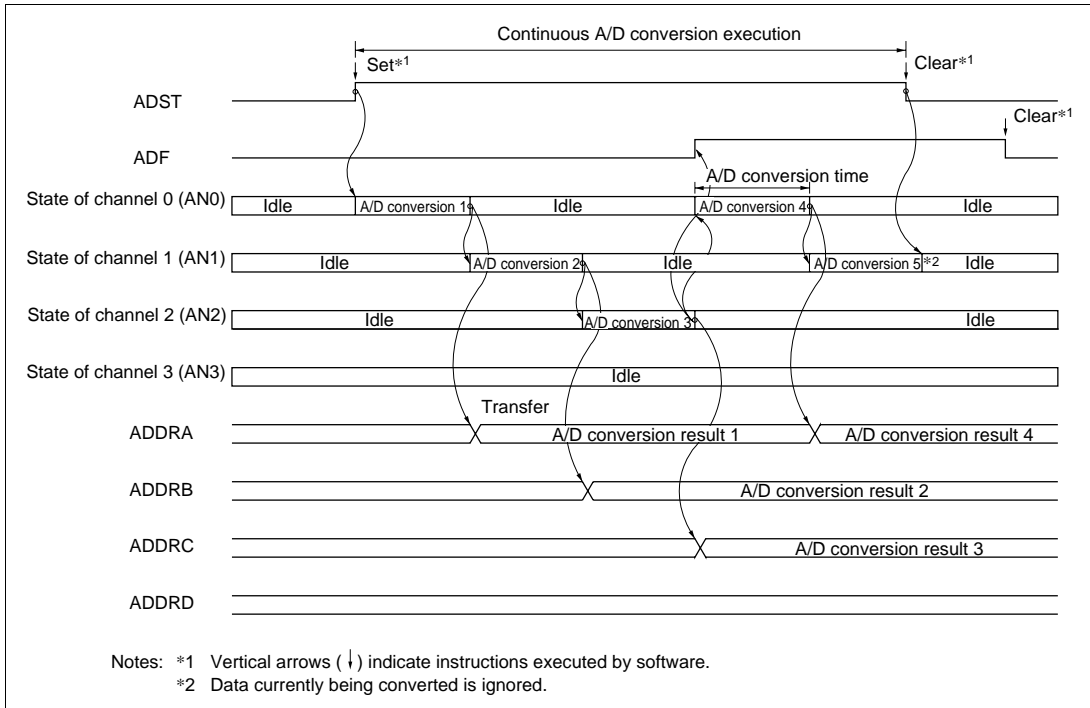
## 15.4.2 Scan Mode (SCAN = 1)

Scan mode is useful for monitoring analog inputs in a group of one or more channels. When the ADST bit is set to 1 by a software, timer or external trigger input, A/D conversion starts on the first channel in the group (AN0). When two or more channels are selected, after conversion of the first channel ends, conversion of the second channel (AN1) starts immediately. A/D conversion continues cyclically on the selected channels until the ADST bit is cleared to 0. The conversion results are transferred for storage into the ADDR registers corresponding to the channels.

When the operating mode or analog input channel must be changed during analog conversion, to prevent incorrect operation, first clear the ADST bit to 0 in ADCSR to halt A/D conversion. After making the necessary changes, set the ADST bit to 1 to start A/D conversion again from the first channel (AN0). The ADST bit can be set at the same time as the operating mode or input channel is changed.

Typical operations when three channels (AN0 to AN2) are selected in scan mode are described next. Figure 15.4 shows a timing diagram for this example.

- [1] Scan mode is selected (SCAN = 1), scan group 0 is selected (CH2 = 0), analog input channels AN0 to AN2 are selected (CH1 = 1, CH0 = 0), and A/D conversion is started (ADST = 1).
- [2] When A/D conversion of the first channel (AN0) is completed, the result is transferred to ADDR<sub>A</sub>. Next, conversion of the second channel (AN1) starts automatically.
- [3] Conversion proceeds in the same way through the third channel (AN2).
- [4] When conversion of all the selected channels (AN0 to AN2) is completed, the ADF flag is set to 1 and conversion of the first channel (AN0) starts again. If the ADIE bit is set to 1 at this time, an ADI interrupt is requested after A/D conversion ends.
- [5] Steps [2] to [4] are repeated as long as the ADST bit remains set to 1. When the ADST bit is cleared to 0, A/D conversion stops. After that, if the ADST bit is set to 1, A/D conversion starts again from the first channel (AN0).



**Figure 15.4 Example of A/D Converter Operation  
(Scan Mode, Channels AN0 to AN2 Selected)**

### 15.4.3 Input Sampling and A/D Conversion Time

The A/D converter has a built-in sample-and-hold circuit. The A/D converter samples the analog input at a time  $t_D$  after the ADST bit is set to 1, then starts conversion. Figure 15.5 shows the A/D conversion timing. Table 15.4 indicates the A/D conversion time.

As indicated in figure 15.5, the A/D conversion time includes  $t_D$  and the input sampling time. The length of  $t_D$  varies depending on the timing of the write access to ADCSR. The total conversion time therefore varies within the ranges indicated in table 15.4.

In scan mode, the values given in table 15.4 apply to the first conversion time. The values given in table 15.5 apply to the second and subsequent conversions.

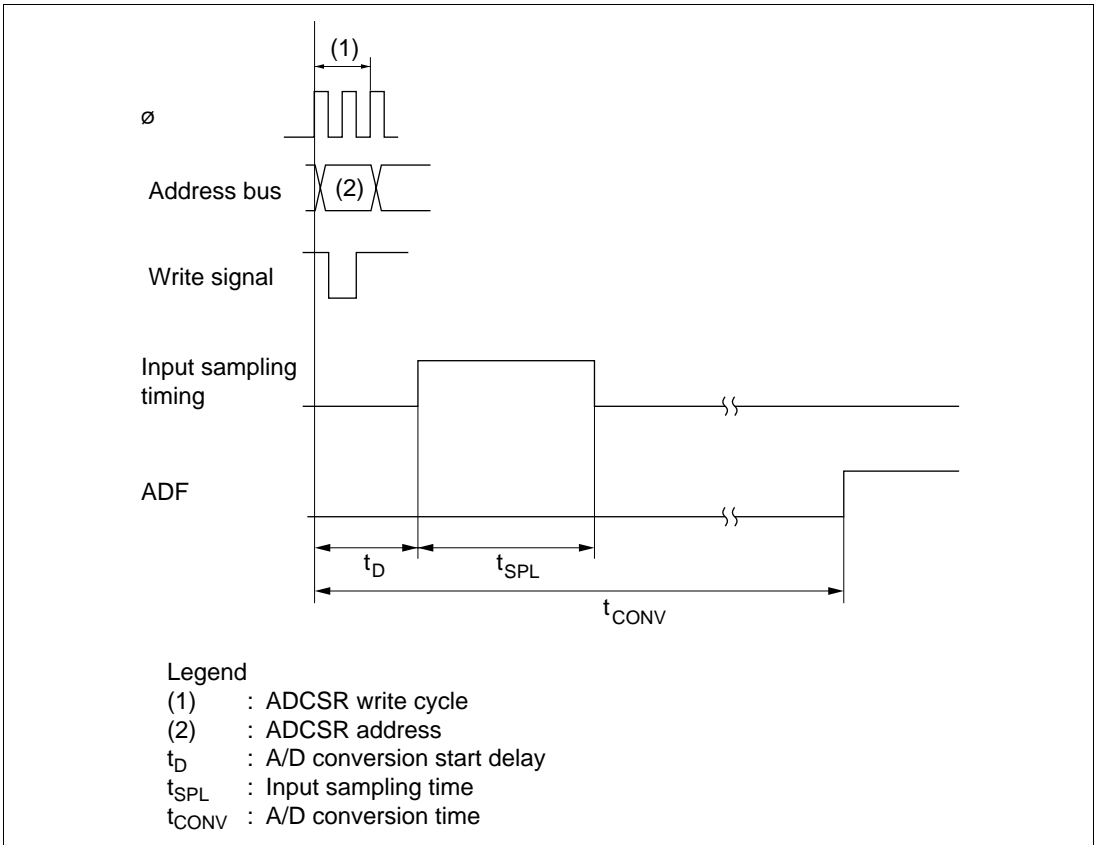


Figure 15.5 A/D Conversion Timing

**Table 15.4 A/D Conversion Time (Single Mode)**

Item	Symbol	CKS1 = 0						CKS1 = 1					
		CKS0 = 0			CKS0 = 1			CKS0 = 0			CKS0 = 1		
		Min	Typ	Max	Min	Typ	Max	Min	Typ	Max	Min	Typ	Max
A/D conversion start delay $t_D$		18	—	33	10	—	17	6	—	9	4	—	5
Input sampling time	$t_{SPL}$	—	127	—	—	63	—	—	31	—	—	15	—
A/D conversion time	$t_{CONV}$	515	—	530	259	—	266	131	—	134	67	—	68

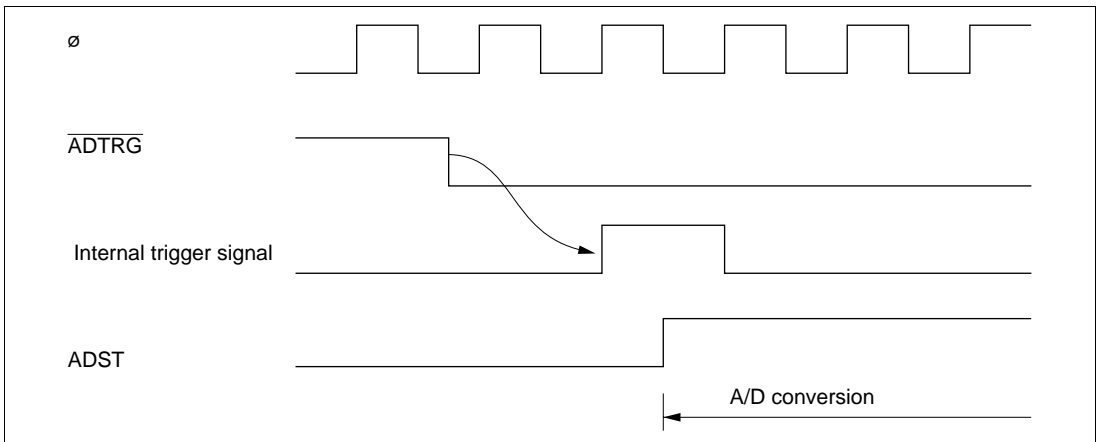
Note: Values in the table are the number of states.

**Table 15.5 A/D Conversion Time (Scan Mode)**

CKS1	CKS0	Conversion Time (State)
0	0	512 (Fixed)
	1	256 (Fixed)
1	0	128 (Fixed)
	1	64 (Fixed)

### 15.4.4 External Trigger Input Timing

A/D conversion can be externally triggered. When the  $\overline{\text{TRGS1}}$  and  $\overline{\text{TRGS0}}$  bits are respectively set to 1 in  $\overline{\text{ADCR}}$ , external trigger input is enabled at the  $\overline{\text{ADTRG}}$  pin. A falling edge at the  $\overline{\text{ADTRG}}$  pin sets the  $\overline{\text{ADST}}$  bit to 1 in  $\overline{\text{ADCSR}}$ , starting A/D conversion. Other operations, in both single and scan modes, are the same as if the  $\overline{\text{ADST}}$  bit has been set to 1 by software. Figure 15.6 shows the timing.



**Figure 15.6 External Trigger Input Timing**

## 15.5 Interrupts

The A/D converter generates an A/D conversion end interrupt (ADI) at the end of A/D conversion. ADI interrupt requests can be enabled or disabled by means of the ADIE bit in ADCSR.

The DTC can be activated by an ADI interrupt. Having the converted data read by the DTC in response to an ADI interrupt enables continuous conversion to be achieved without imposing a load on software.

The A/D converter interrupt source is shown in table 15.6.

**Table 15.6 A/D Converter Interrupt Source**

Interrupt Source	Description	DTC Activation
ADI	Interrupt due to end of conversion	Possible

## 15.6 Usage Notes

The following points should be noted when using the A/D converter.

### Setting Range of Analog Power Supply and Other Pins:

#### (1) Analog input voltage range

The voltage applied to analog input pin ANn during A/D conversion should be in the range  $AV_{SS} \leq ANn \leq V_{ref}$ .

#### (2) Relation between AVcc, AVss and Vcc, Vss

As the relationship between AVcc, AVss and Vcc, Vss, set  $AV_{SS} = V_{SS}$ . If the A/D converter is not used, the AVCC and AVSS pins must on no account be left open.

#### (3) Vref input range

The analog reference voltage input at the Vref pin set in the range  $V_{ref} \leq AV_{CC}$ .

If conditions (1), (2), and (3) above are not met, the reliability of the device may be adversely affected.

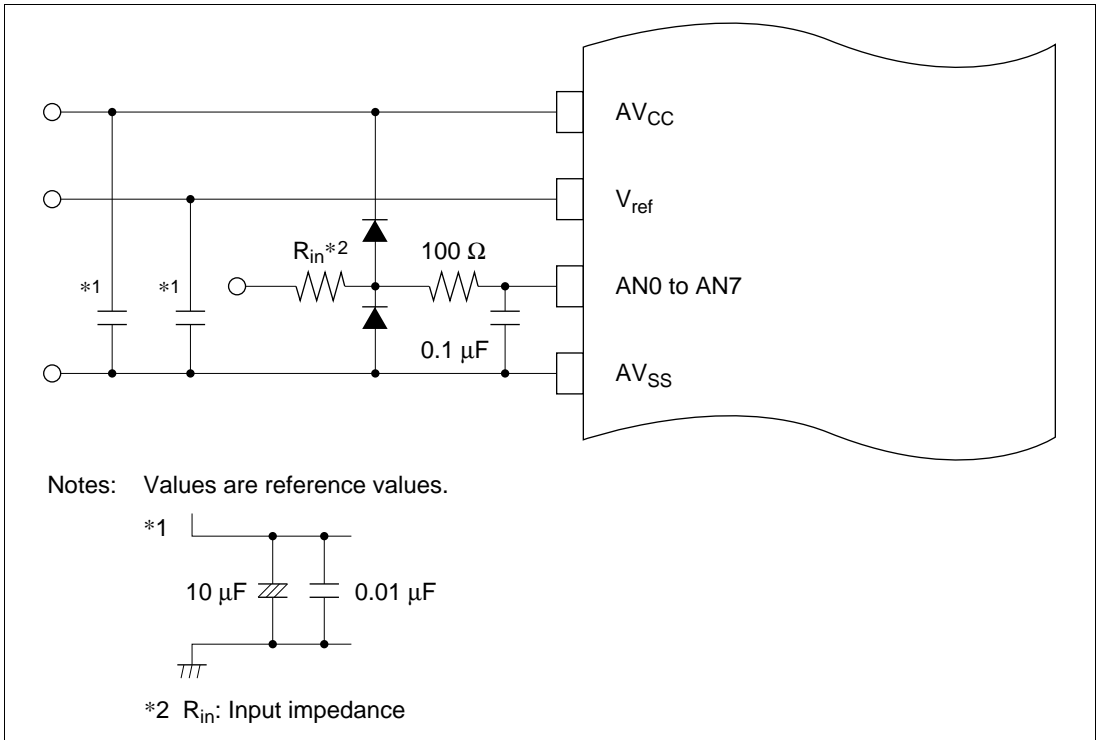
**Notes on Board Design:** In board design, digital circuitry and analog circuitry should be as mutually isolated as possible, and layout in which digital circuit signal lines and analog circuit signal lines cross or are in close proximity should be avoided as far as possible. Failure to do so may result in incorrect operation of the analog circuitry due to inductance, adversely affecting A/D conversion values.

Also, digital circuitry must be isolated from the analog input signals (AN0 to AN7), analog reference power supply (Vref), and analog power supply (AVcc) by the analog ground (AVss). Also, the analog ground (AVss) should be connected at one point to a stable digital ground (Vss) on the board.

**Notes on Noise Countermeasures:** A protection circuit connected to prevent damage due to an abnormal voltage such as an excessive surge at the analog input pins (AN0 to AN7) and analog reference power supply (Vref) should be connected between AVcc and AVss as shown in figure 15.7.

Also, the bypass capacitors connected to AVcc and Vref and the filter capacitor connected to AN0 to AN7 must be connected to AVss.

If a filter capacitor is connected as shown in figure 15.7, the input currents at the analog input pins (AN0 to AN7) are averaged, and so an error may arise. Also, when A/D conversion is performed frequently, as in scan mode, if the current charged and discharged by the capacitance of the sample-and-hold circuit in the A/D converter exceeds the current input via the input impedance ( $R_{in}$ ), an error will arise in the analog input pin voltage. Careful consideration is therefore required when deciding the circuit constants.

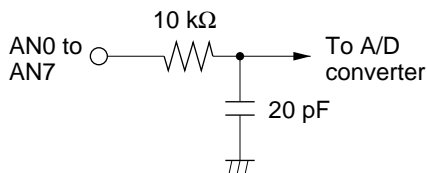


**Figure 15.7 Example of Analog Input Protection Circuit**

**Table 15.7 Analog Pin Specifications**

Item	Min	Max	Unit
Analog input capacitance	—	20	pF
Permissible signal source impedance	—	5*	k $\Omega$

Note: \* When  $V_{CC} = 2.7\text{ V to }3.6\text{ V}$

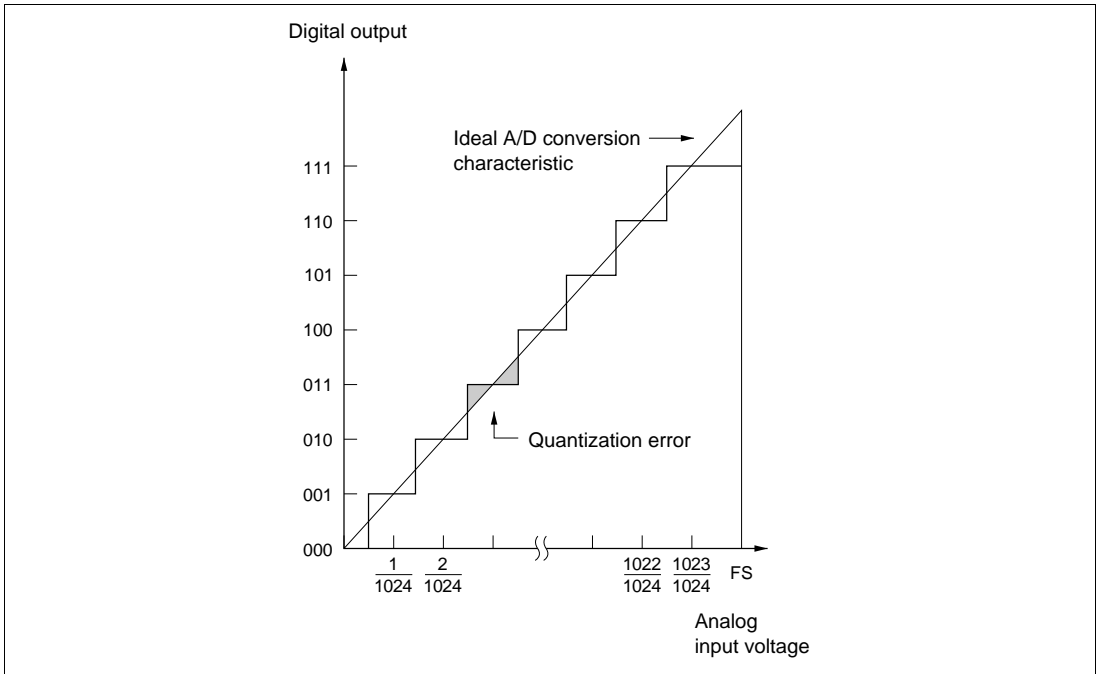


Note: Values are reference values.

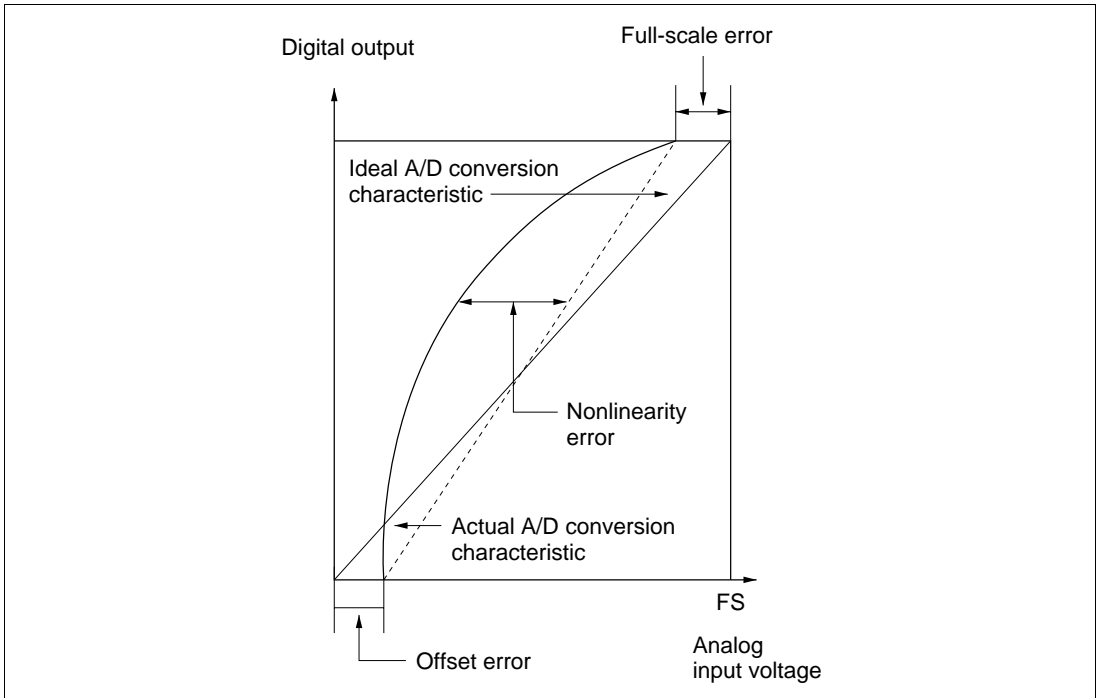
**Figure 15.8 Analog Input Pin Equivalent Circuit**

**A/D Conversion Precision Definitions:** LSI A/D conversion precision definitions are given below.

- Resolution  
The number of A/D converter digital output codes
- Offset error  
The deviation of the analog input voltage value from the ideal A/D conversion characteristic when the digital output changes from the minimum voltage value B'000000000 (H'000) to B'000000001 (H'001) (see figure 15.10).
- Full-scale error  
The deviation of the analog input voltage value from the ideal A/D conversion characteristic when the digital output changes from B'111111110 (H'3FE) to B'111111111 (H'3FF) (see figure 15.10).
- Quantization error  
The deviation inherent in the A/D converter, given by 1/2 LSB (see figure 15.9).
- Nonlinearity error  
The error with respect to the ideal A/D conversion characteristic between the zero voltage and the full-scale voltage. Does not include the offset error, full-scale error, or quantization error.
- Absolute precision  
The deviation between the digital value and the analog input value. Includes the offset error, full-scale error, quantization error, and nonlinearity error.



**Figure 15.9 A/D Conversion Precision Definitions (1)**



**Figure 15.10 A/D Conversion Precision Definitions (2)**



**Permissible Signal Source Impedance:** LSI analog input is designed so that conversion precision is guaranteed for an input signal for which the signal source impedance is  $5\text{ k}\Omega$  or less. This specification is provided to enable the A/D converter's sample-and-hold circuit input capacitance to be charged within the sampling time; if the sensor output impedance exceeds  $5\text{ k}\Omega$ , charging may be insufficient and it may not be possible to guarantee the A/D conversion precision.

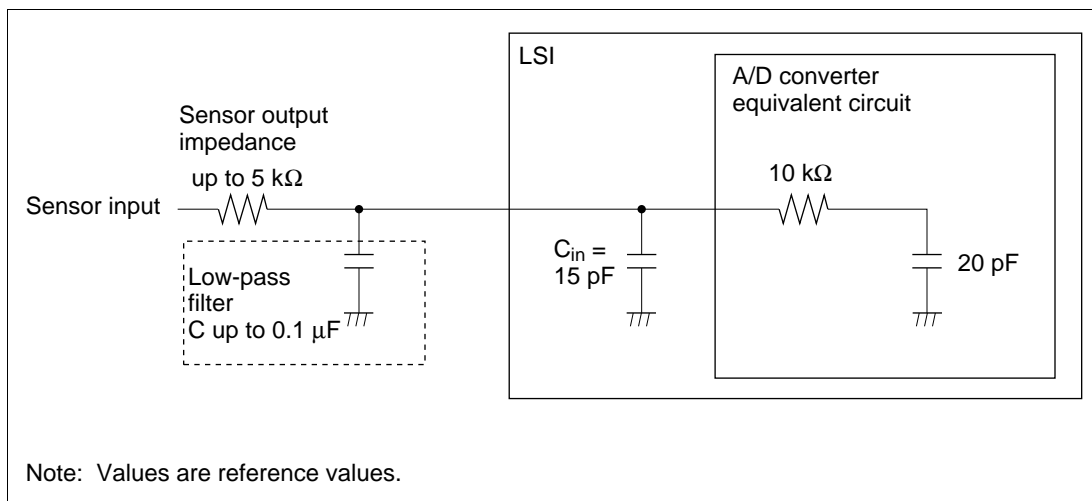
However, if a large capacitance is provided externally, the input load will essentially comprise only the internal input resistance of  $10\text{ k}\Omega$ , and the signal source impedance is ignored.

However, since a low-pass filter effect is obtained in this case, it may not be possible to follow an analog signal with a large differential coefficient (e.g.,  $5\text{ mV}/\mu\text{s}$  or greater).

When converting a high-speed analog signal, a low-impedance buffer should be inserted.

**Influences on Absolute Precision:** Adding capacitance results in coupling with GND, and therefore noise in GND may adversely affect absolute precision. Be sure to make the connection to an electrically stable GND such as  $AV_{SS}$ .

Care is also required to insure that filter circuits do not communicate with digital signals on the mounting board, so acting as antennas.



**Figure 15.11** Example of Analog Input Circuit



# Section 16 RAM

## 16.1 Overview

The LSI has 16 kbytes of on-chip high-speed static RAM. The RAM is connected to the CPU by a 16-bit data bus, enabling one-state access by the CPU to both byte data and word data. This makes it possible to perform fast word data transfer.

The on-chip RAM can be enabled or disabled by means of the RAM enable bit (RAME) in the system control register (SYSCR).

### 16.1.1 Block Diagram

Figure 16.1 shows a block diagram of the on-chip RAM.

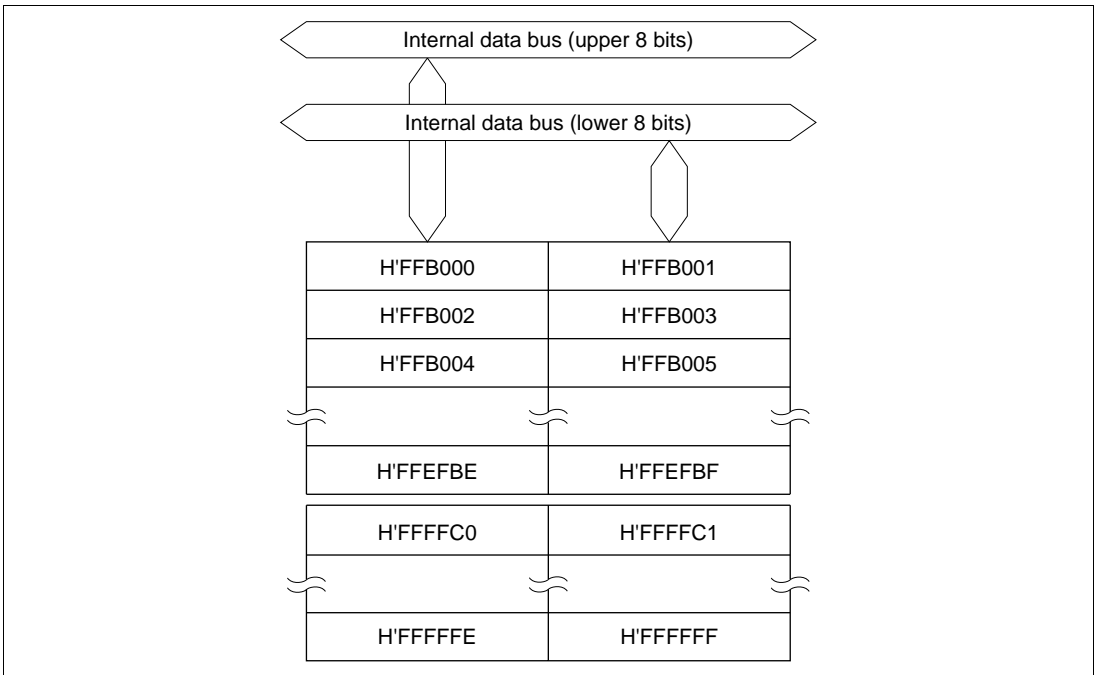


Figure 16.1 Block Diagram of RAM

## 16.1.2 Register Configuration

The on-chip RAM is controlled by SYSCR. Table 16.1 shows the address and initial value of SYSCR.

**Table 16.1 RAM Register**

Name	Abbreviation	R/W	Initial Value	Address*
System control register	SYSCR	R/W	H'01	H'FDE5

Note: \* Lower 16 bits of the address.

## 16.2 Register Descriptions

### 16.2.1 System Control Register (SYSCR)

Bit	:	7	6	5	4	3	2	1	0
		—	—	INTM1	INTM0	NMIEG	MRESE	—	RAME
Initial value :		0	0	0	0	0	0	0	1
R/W	:	R/W	—	R/W	R/W	R/W	R/W	—	R/W

The on-chip RAM is enabled or disabled by the RAME bit in SYSCR. For details of other bits in SYSCR, see section 3.2.2, System Control Register (SYSCR).

**Bit 0—RAM Enable (RAME):** Enables or disables the on-chip RAM. The RAME bit is initialized when the reset state is released. It is not initialized in software standby mode.

#### Bit 0

RAME	Description
0	On-chip RAM is disabled
1	On-chip RAM is enabled (Initial value)

Note: When the DTC is used, the RAME bit must be set to 1.

## 16.3 Operation

When the RAME bit is set to 1, accesses to addresses H'FFB000 to H'FFEFBF and H'FFFC0 to H'FFFFFF in the LSI is directed to the on-chip RAM. When the RAME bit is cleared to 0, the off-chip address space is accessed.

Since the on-chip RAM is connected to the CPU by an internal 16-bit data bus, it can be written to and read in byte or word units. Each type of access can be performed in one state.

Even addresses use the upper 8 bits, and odd addresses use the lower 8 bits. Word data must start at an even address.

## 16.4 Usage Note

DTC register information can be located in addresses H'FFEBC0 to H'FFEFBF. When the DTC is used, the RAME bit must not be cleared to 0.



# Section 17 ROM

## 17.1 Overview

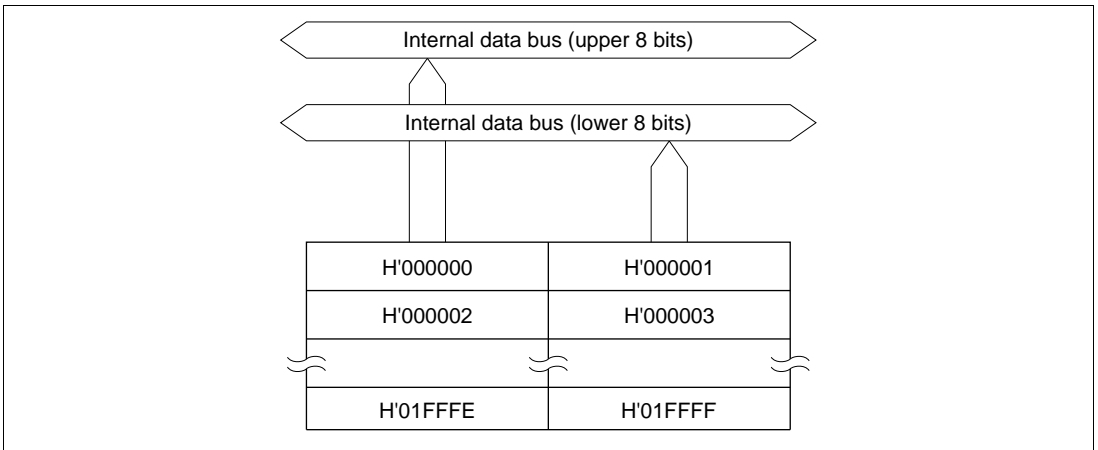
The LSI has 128 kbytes of on-chip ROM (flash memory). The ROM is connected to the CPU by a 16-bit data bus. The CPU accesses both byte data and word data in one state, making possible rapid instruction fetches and high-speed processing.

The on-chip ROM is enabled or disabled by setting the mode pins (MD2, MD1, and MD0).

The flash memory versions can be erased and programmed on-board as well as with a PROM programmer.

### 17.1.1 Block Diagram

Figure 17.1 shows a block diagram of the on-chip ROM.



**Figure 17.1 Block Diagram of ROM**

## 17.1.2 Register Configuration

This LSI's on-chip ROM is controlled by the mode pins. The register configuration is shown in table 17.1.

**Table 17.1 ROM Register**

Name	Abbreviation	R/W	Initial Value	Address*
Mode control register	MDCR	R/W	Undefined	H'FDE7

Note: \* Lower 16 bits of the address.

## 17.2 Register Descriptions

### 17.2.1 Mode Control Register (MDCR)

Bit	:	7	6	5	4	3	2	1	0
		—	—	—	—	—	MDS2	MDS1	MDS0
Initial value	:	1	0	0	0	0	—*	—*	—*
R/W	:	—	—	—	—	—	R	R	R

Note: \* Determined by pins MD2 to MD0.

MDCR is an 8-bit read-only register that indicates the current operating mode of the LSI.

**Bit 7—Reserved:** This bit cannot be modified and is always read as 1.

**Bits 6 to 3—Reserved:** These bits cannot be modified and are always read as 0.

**Bits 2 to 0—Mode Select 2 to 0 (MDS2 to MDS0):** These bits indicate the input levels at pins MD2 to MD0 (the current operating mode). Bits MDS2 to MDS0 correspond to pins MD2 to MD0. MDS2 to MDS0 are read-only bits, and cannot be written to. The mode pin (MD2 to MD0) input levels are latched into these bits when MDCR is read. These latches are canceled by a power-on reset.

## 17.3 Operation

The on-chip ROM is connected to the CPU by a 16-bit data bus, and both byte and word data can be accessed in one state. Even addresses are connected to the upper 8 bits, and odd addresses to the lower 8 bits. Word data must start at an even address.

The on-chip ROM is enabled and disabled by setting the mode pins (MD2, MD1, and MD0). These settings are shown in table 17.2.



**Table 17.2 Operating Modes and ROM Area (F-ZTAT version)**

Operating Mode	Mode Pin				On-Chip ROM
	FWE	MD2	MD1	MD0	
Mode 0 —	0	0	0	0	—
Mode 1				1	
Mode 2			1	0	
Mode 3				1	
Mode 4 Advanced expanded mode with on-chip ROM disabled	1	0	0		Disabled
Mode 5 Advanced expanded mode with on-chip ROM disabled				1	
Mode 6 Advanced expanded mode with on-chip ROM enabled			1	0	Enabled (128 kbytes)* <sup>1</sup>
Mode 7 Advanced single-chip mode				1	Enabled (128 kbytes)* <sup>1</sup>
Mode 8 —	1	0	0	0	—
Mode 9				1	
Mode 10 Boot mode (advanced expanded mode with on-chip ROM enabled)* <sup>1</sup>			1	0	Enabled (128 kbytes)* <sup>2</sup>
Mode 11 Boot mode (advanced single-chip mode)* <sup>2</sup>				1	Enabled (128 kbytes)* <sup>2</sup>
Mode 12 —	1	0	0		—
Mode 13				1	
Mode 14 User program mode (advanced expanded mode with on-chip ROM enabled)* <sup>1</sup>			1	0	Enabled (128 kbytes)* <sup>1</sup>
Mode 15 User program mode (advanced single-chip mode)* <sup>2</sup>				1	Enabled (128 kbytes)* <sup>1</sup>

Notes: \*<sup>1</sup> Apart from the fact that flash memory can be erased and programmed, operation is the same as in advanced expanded mode with on-chip ROM enabled.

\*<sup>2</sup> Apart from the fact that flash memory can be erased and programmed, operation is the same as in advanced single-chip mode.

## 17.4 Overview of Flash Memory

### 17.4.1 Features

The LSI has 128 kbytes of on-chip flash memory. The features of the flash memory are summarized below.

- Four flash memory operating modes
  - Program mode
  - Erase mode
  - Program-verify mode
  - Erase-verify mode
- Programming/erase methods

The flash memory is programmed 128 bytes at a time. Block erase (in single-block units) can be performed. To erase multiple blocks, each block must be erased in turn. Block erasing can be performed as required on 1 kbyte, 8 kbytes, 16 kbytes, 28 kbytes, and 32 kbytes blocks.
- Programming/erase times

The flash memory programming time is 10 ms (typ.) for simultaneous 128-byte programming, equivalent approximately to 80  $\mu$ s (typ.) per byte, and the erase time is 100 ms (typ.).
- Reprogramming capability

The flash memory can be reprogrammed up to 100 times.
- On-board programming modes

There are two modes in which flash memory can be programmed/erased/verified on-board:

  - Boot mode
  - User program mode
- Automatic bit rate adjustment

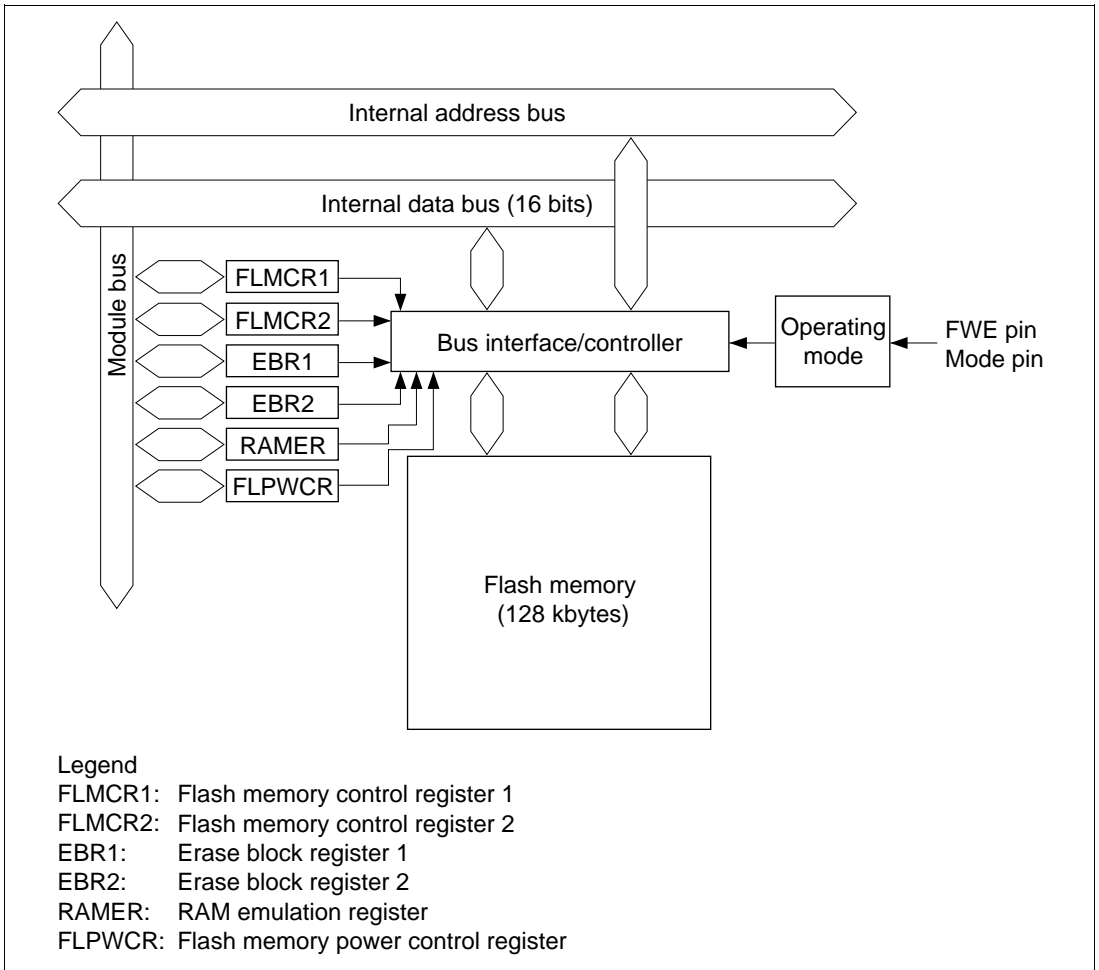
With data transfer in boot mode, the LSI's bit rate can be automatically adjusted to match the transfer bit rate of the host.
- Flash memory emulation in RAM

Flash memory programming can be emulated in real time by overlapping a part of RAM onto flash memory.
- Protect modes

There are three protect modes, hardware, software, and error protection, which allow protected status to be designated for flash memory program/erase/verify operations.
- Programmer mode

Flash memory can be programmed/erased in programmer mode, using a PROM programmer, as well as in on-board programming mode.

## 17.4.2 Block Diagram

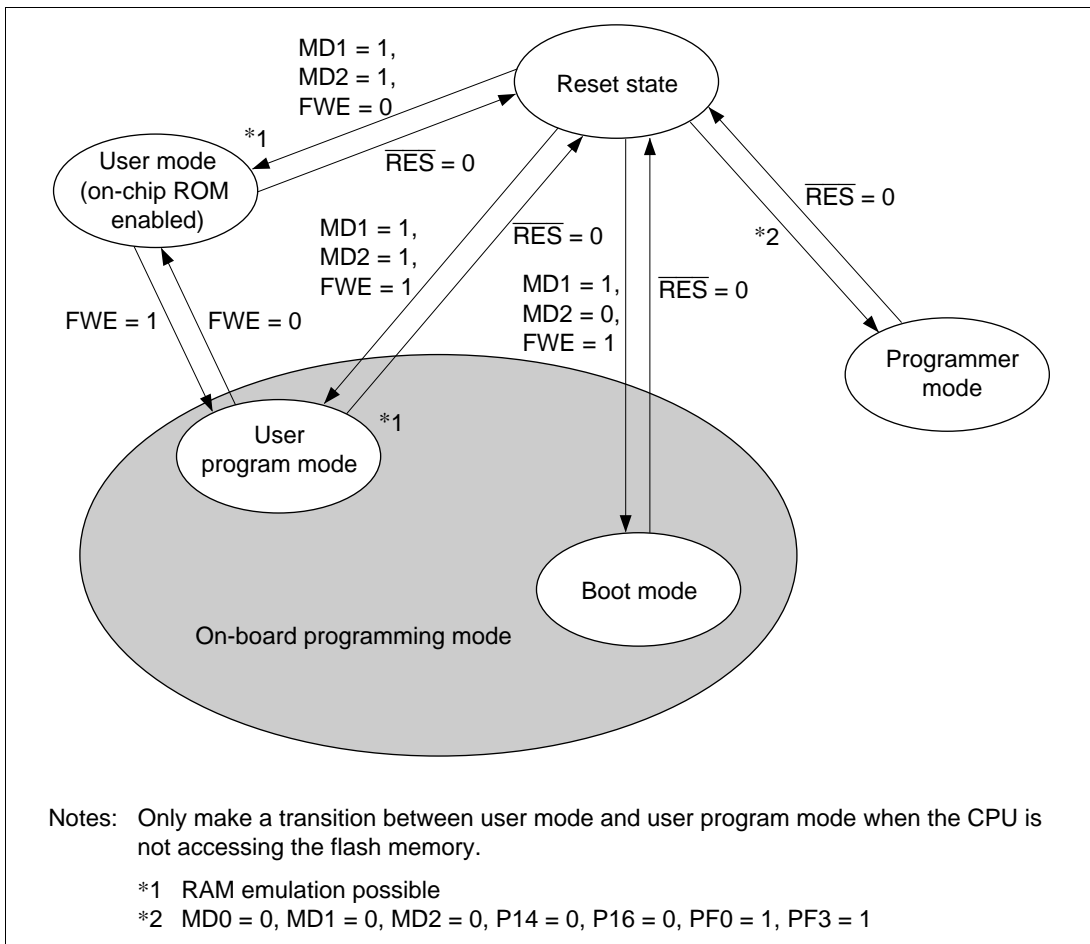


**Figure 17.2 Block Diagram of Flash Memory**

### 17.4.3 Mode Transitions

When the mode pins and the FWE pin are set in the reset state and a reset-start is executed, the microcomputer enters an operating mode as shown in figure 17.3. In user mode, flash memory can be read but not programmed or erased. Transitions between user mode and user program mode should only be made when the CPU is not accessing the flash memory.

The boot, user program and programmer modes are provided as modes to write and erase the flash memory.



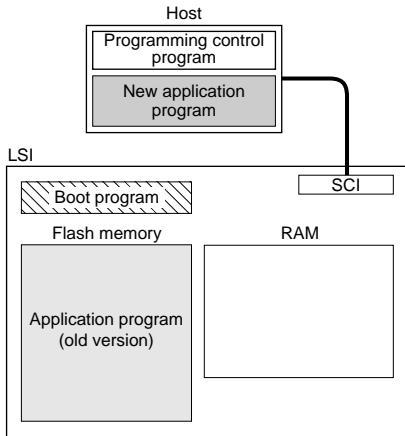
**Figure 17.3 Flash Memory State Transitions**

## 17.4.4 On-Board Programming Modes

### Boot Mode

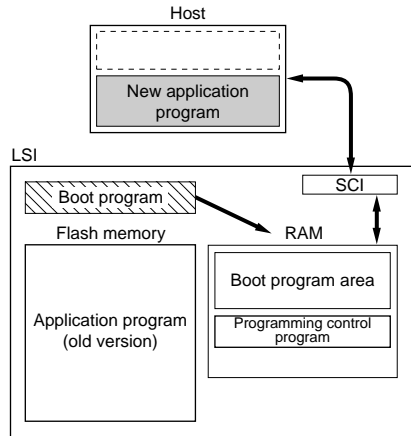
#### 1. Initial state

The old program version or data remains written in the flash memory. The user should prepare the programming control program and new application program beforehand in the host.



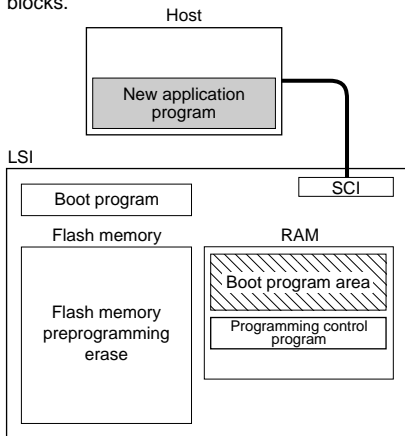
#### 2. Programming control program transfer

When boot mode is entered, the boot program in the LSI (originally incorporated in the chip) is started and the programming control program in the host is transferred to RAM via SCI communication. The boot program required for flash memory erasing is automatically transferred to the RAM boot program area.



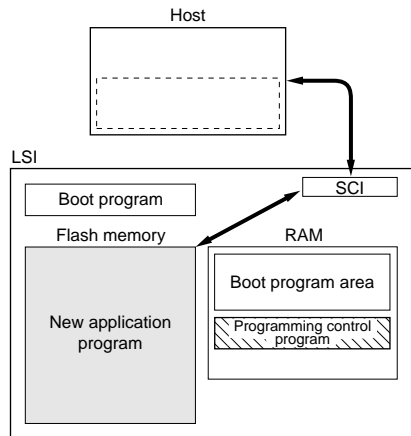
#### 3. Flash memory initialization

The erase program in the boot program area (in RAM) is executed, and the flash memory is initialized (to H'FF). In boot mode, total flash memory erasure is performed, without regard to blocks.



#### 4. Writing new application program

The programming control program transferred from the host to RAM is executed, and the new application program in the host is written into the flash memory.




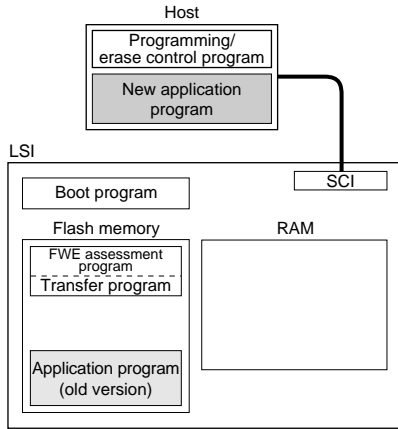
 Program execution state

Figure 17.4 Boot Mode

# User Program Mode

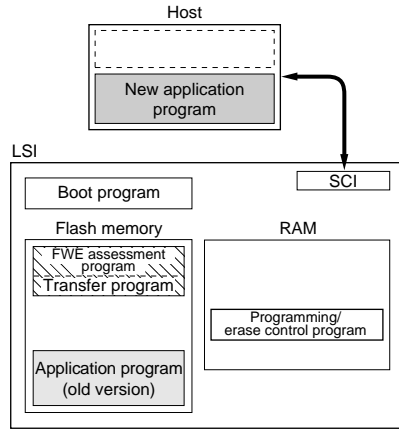
## 1. Initial state

The FWE assessment program that confirms that user program mode has been entered, and the program that will transfer the programming/erase control program from flash memory to on-chip RAM should be written into the flash memory by the user beforehand. The programming/erase control program should be prepared in the host or in the flash memory.



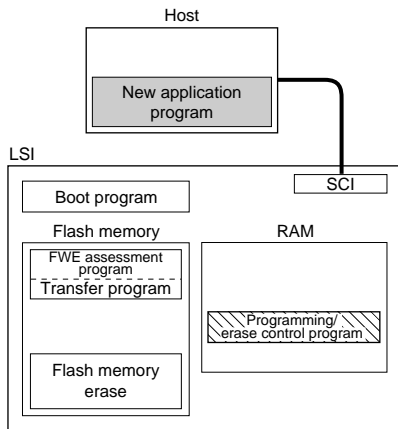
## 2. Programming/erase control program transfer

When user program mode is entered, user software confirms this fact, executes transfer program in the flash memory, and transfers the programming/erase control program to RAM.



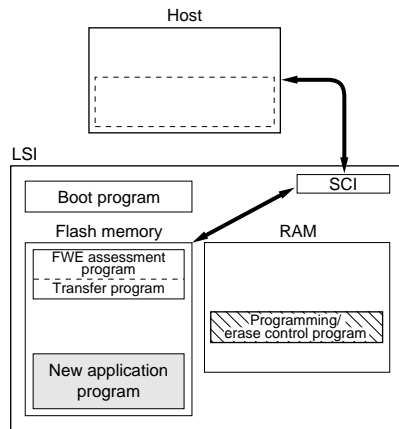
## 3. Flash memory initialization


The programming/erase program in RAM is executed, and the flash memory is initialized (to H'FF). Erasing can be performed in block units, but not in byte units.



## 4. Writing new application program

Next, the new application program in the host is written into the erased flash memory blocks. Do not write to unerased blocks.

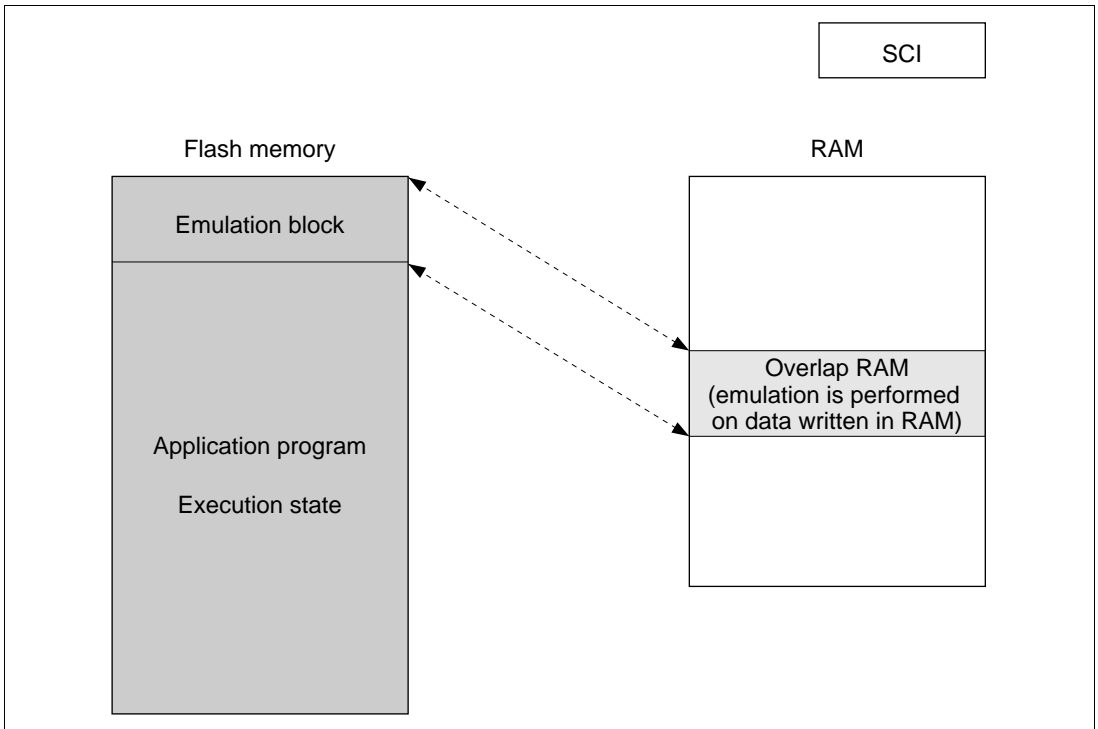


 Program execution state

**Figure 17.5 User Program Mode**

## 17.4.5 Flash Memory Emulation in RAM

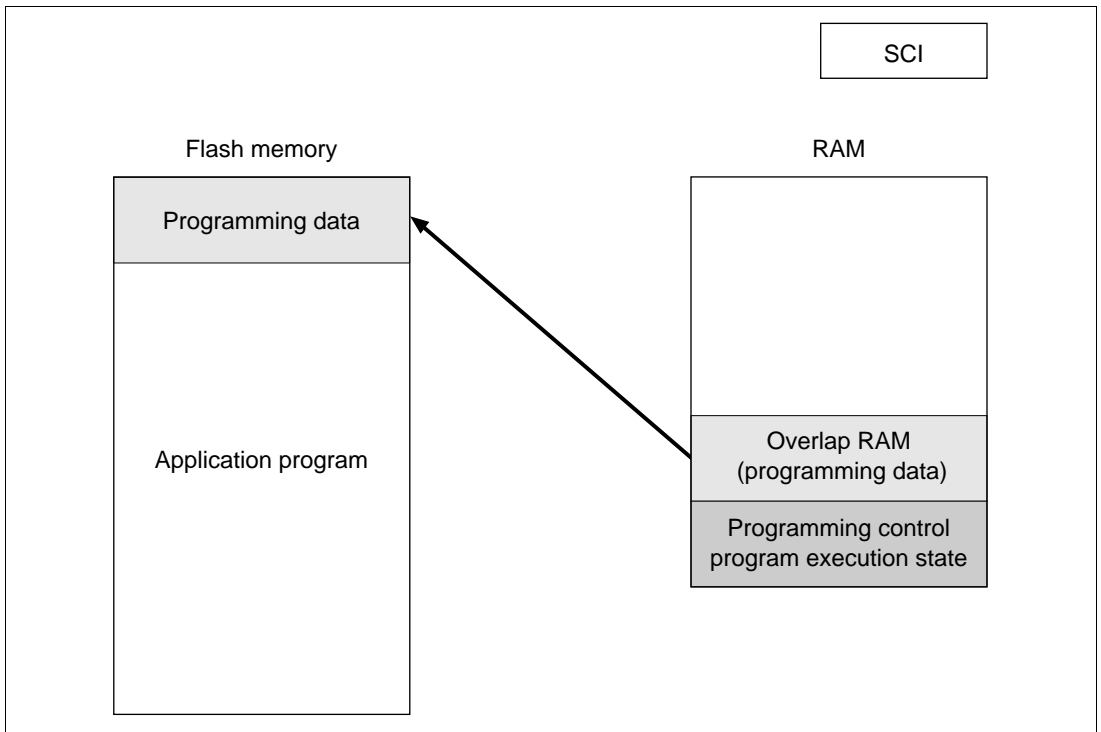
Emulation should be performed in user mode or user program mode. When the emulation block set in RAMER is accessed while the emulation function is being executed, data written in the overlap RAM is read.



**Figure 17.6 Reading Overlap RAM Data in User Mode or User Program Mode**

When overlap RAM data is confirmed, the RAMS bit is cleared, RAM overlap is released, and writes should actually be performed to the flash memory.

When the programming control program is transferred to RAM, ensure that the transfer destination and the overlap RAM do not overlap, as this will cause data in the overlap RAM to be rewritten.



**Figure 17.7 Writing Overlap RAM Data in User Program Mode**

#### 17.4.6 Differences between Boot Mode and User Program Mode

**Table 17.3 Differences between Boot Mode and User Program Mode**

	<b>Boot Mode</b>	<b>User Program Mode</b>
Total erase	Yes	Yes
Block erase	No	Yes
Programming control program*	(2)	(1) (2) (3)

(1) Erase/erase-verify

(2) Program/program-verify

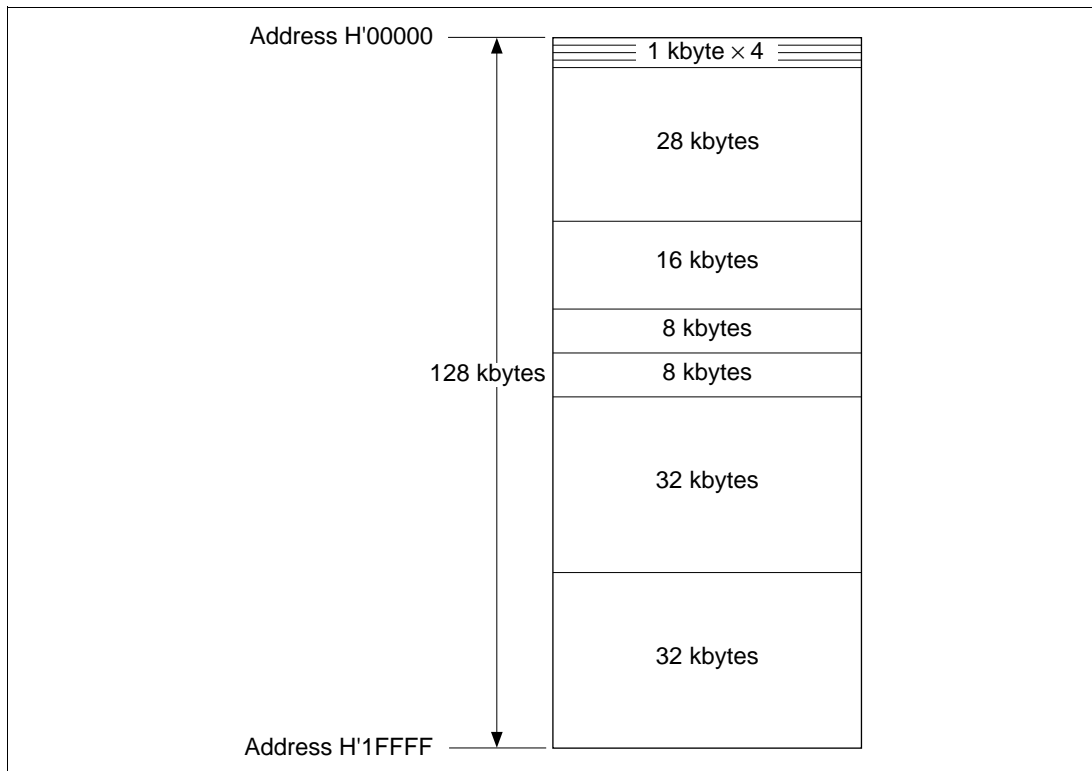
(3) Emulation

Note: \* To be provided by the user, in accordance with the recommended algorithm.



## 17.4.7 Block Configuration

The flash memory is divided into four 1 kbyte blocks, one 28 kbytes block, one 16 kbytes block, two 8 kbytes blocks, and two 32 kbytes blocks. Erasure is performed in this unit.



**Figure 17.8 Flash Memory Block Configuration**

## 17.5 Pin Configuration

The flash memory is controlled by means of the pins shown in table 17.4.

**Table 17.4 Pin Configuration**

Pin Name	Abbreviation	I/O	Function
Reset	$\overline{\text{RES}}$	Input	Reset
Flash write enable	FWE	Input	Flash memory program/erase protection by hardware
Mode 2	MD2	Input	Sets LSI operating mode
Mode 1	MD1	Input	Sets LSI operating mode
Mode 0	MD0	Input	Sets LSI operating mode
Port F3	PF3	Input	Sets LSI operating mode when MD2 = MD1 = MD0 =0
Port F0	PF0	Input	Sets LSI operating mode when MD2 = MD1 = MD0 =0
Port 16	P16	Input	Sets LSI operating mode when MD2 = MD1 = MD0 =0
Port 14	P14	Input	Sets LSI operating mode when MD2 = MD1 = MD0 =0
Transmit data	TxD0	Output	Serial transmit data output
Receive data	RxD0	Input	Serial receive data input

## 17.6 Register Configuration

The registers used to control the on-chip flash memory when enabled are shown in table 17.5. In order to access these registers, the FLSHE bit in SCRX must be set to 1 (except for RAMER, SCRX).

**Table 17.5 Register Configuration**

Register Name	Abbreviation	R/W	Initial Value	Address* <sup>1</sup>
Flash memory control register 1	FLMCR1* <sup>5</sup>	R/W* <sup>2</sup>	H'00* <sup>3</sup>	H'FFA8
Flash memory control register 2	FLMCR2* <sup>5</sup>	R* <sup>2</sup>	H'00	H'FFA9
Erase block register 1	EBR1* <sup>5</sup>	R/W* <sup>2</sup>	H'00* <sup>4</sup>	H'FFAA
Erase block register 2	EBR2* <sup>5</sup>	R/W* <sup>2</sup>	H'00* <sup>4</sup>	H'FFAB
RAM emulation register	RAMER* <sup>5</sup>	R/W	H'00	H'FEDB
Flash memory power control register	FLPWCR* <sup>5</sup>	R/W	H'00	H'FFAC
Serial control register X	SCRX	R/W	H'00	H'FDB4

Notes: \*<sup>1</sup> Lower 16 bits of the address.

\*<sup>2</sup> To access these registers, set the FLSHE bit to 1 in serial control register X. Even if FLSHE is set to 1, if the chip is in a mode in which the on-chip flash memory is disabled, a read will return H'00 and writes are invalid. Writes are also invalid when the FWE bit in FLMCR1 is not set to 1.

\*<sup>3</sup> When a high level is input to the FWE pin, the initial value is H'80.

\*<sup>4</sup> When a low level is input to the FWE pin, or if a high level is input and the SWE1 bit in FLMCR1 is not set, these registers are initialized to H'00.

\*<sup>5</sup> FLMCR1, FLMCR2, EBR1, EBR2, RAMER, and FLPWCR are 8-bit registers.

Only byte access can be used on these registers, with the access requiring two states.

## 17.7 Register Descriptions

### 17.7.1 Flash Memory Control Register 1 (FLMCR1)

Bit	:	7	6	5	4	3	2	1	0
		FWE	SWE1	ESU1	PSU1	EV1	PV1	E1	P1
Initial value	:	—*	0	0	0	0	0	0	0
R/W	:	R	R/W	R/W	R/W	R/W	R/W	R/W	R/W

Note: \* Determined by the state of the FWE pin.

FLMCR1 is an 8-bit register used for flash memory operating mode control. Program-verify mode or erase-verify mode for addresses H'00000 to H'1FFFF is entered by setting SWE1 bit to 1 when FWE = 1, then setting the PV1 or EV1 bit. Program mode for addresses H'00000 to H'1FFFF is entered by setting SWE1 bit to 1 when FWE = 1, then setting the PSU1 bit, and finally setting the P1 bit. Erase mode for addresses H'00000 to H'1FFFF is entered by setting SWE1 bit to 1 when FWE = 1, then setting the ESU1 bit, and finally setting the E1 bit. FLMCR1 is initialized by a power-on reset, and in hardware standby mode and software standby mode. Its initial value is H'80 when a high level is input to the FWE pin, and H'00 when a low level is input. When on-chip flash memory is disabled, a read will return H'00, and writes are invalid.

Writes are enabled only in the following cases: Writes to bit SWE1 of FLMCR1 enabled when FWE = 1, to bits ESU1, PSU1, EV1, and PV1 when FWE = 1 and SWE1 = 1, to bit E1 when FWE = 1, SWE1 = 1 and ESU1 = 1, and to bit P1 when FWE = 1, SWE1 = 1, and PSU1 = 1.

**Bit 7—Flash Write Enable Bit (FWE):** Sets hardware protection against flash memory programming/erasing.

#### Bit 7

FWE	Description
0	When a low level is input to the FWE pin (hardware-protected state)
1	When a high level is input to the FWE pin

**Bit 6—Software Write Enable Bit 1 (SWE1):** Enables or disables flash memory programming and erasing. Set this bit when setting bits 5 to 0, bits 7 to 0 of EBR1, and bits 3 to 0 of EBR2.

#### Bit 6

SWE1	Description
0	Writes disabled (Initial value)
1	Writes enabled [Setting condition] When FWE = 1

**Bit 5—Erase Setup Bit 1 (ESU1):** Prepares for a transition to erase mode. Set this bit to 1 before setting the E1 bit in FLMCR1 to 1. Do not set the SWE1, PSU1, EV1, PV1, E1, or P1 bit at the same time.

#### Bit 5

ESU1	Description
0	Erase setup cleared (Initial value)
1	Erase setup [Setting condition] When FWE = 1 and SWE1 = 1

**Bit 4—Program Setup Bit 1 (PSU1):** Prepares for a transition to program mode. Set this bit to 1 before setting the P1 bit in FLMCR1 to 1. Do not set the SWE1, ESU1, EV1, PV1, E1, or P1 bit at the same time.

#### Bit 4

PSU1	Description
0	Program setup cleared (Initial value)
1	Program setup [Setting condition] When FWE = 1 and SWE1 = 1

**Bit 3—Erase-Verify 1 (EV1):** Selects erase-verify mode transition or clearing. Do not set the SWE1, ESU1, PSU1, PV1, E1, or P1 bit at the same time.

**Bit 3**

<b>EV1</b>	<b>Description</b>	
0	Erase-verify mode cleared	(Initial value)
1	Transition to erase-verify mode [Setting condition] When FWE = 1 and SWE1 = 1	

**Bit 2—Program-Verify 1 (PV1):** Selects program-verify mode transition or clearing. Do not set the SWE1, ESU1, PSU1, EV1, E1, or P1 bit at the same time.

**Bit 2**

<b>PV1</b>	<b>Description</b>	
0	Program-verify mode cleared	(Initial value)
1	Transition to program-verify mode [Setting condition] When FWE = 1 and SWE1 = 1	

**Bit 1—Erase 1 (E1):** Selects erase mode transition or clearing. Do not set the SWE1, ESU1, PSU1, EV1, PV1, or P1 bit at the same time.

**Bit 1**

<b>E1</b>	<b>Description</b>	
0	Erase mode cleared	(Initial value)
1	Transition to erase mode [Setting condition] When FWE = 1, SWE1 = 1, and ESU1 = 1	

**Bit 0—Program 1 (P1):** Selects program mode transition or clearing. Do not set the SWE1, PSU1, ESU1, EV1, PV1, or E1 bit at the same time.

#### Bit 0

P1	Description
0	Program mode cleared (Initial value)
1	Transition to program mode [Setting condition] When FWE = 1, SWE1 = 1, and PSU1 = 1

### 17.7.2 Flash Memory Control Register 2 (FLMCR2)

Bit	7	6	5	4	3	2	1	0
	FLER	—	—	—	—	—	—	—
Initial value	0	0	0	0	0	0	0	0
R/W	R	R	R	R	R	R	R	R

Note: FLMCR2 is a read-only register, and should not be written to.

FLMCR2 is an 8-bit register used for flash memory operating mode control. FLMCR2 is initialized to H'00 by a power-on reset, and in hardware standby mode and software standby mode. When on-chip flash memory is disabled, a read will return H'00.

**Bit 7—Flash Memory Error (FLER):** Indicates that an error has occurred during an operation on flash memory (programming or erasing). When FLER is set to 1, flash memory goes to the error-protection state.

#### Bit 7

FLER	Description
0	Flash memory is operating normally (Initial value) Flash memory program/erase protection (error protection) is disabled [Clearing condition] Power-on reset or hardware standby mode
1	An error has occurred during flash memory programming/erasing Flash memory program/erase protection (error protection) is enabled [Setting condition] See 17.10.3 Error Protection

**Bits 6 to 0—Reserved:** These bits always read 0.

### 17.7.3 Erase Block Register 1 (EBR1)

Bit	:	7	6	5	4	3	2	1	0
		EB7	EB6	EB5	EB4	EB3	EB2	EB1	EB0
Initial value	:	0	0	0	0	0	0	0	0
R/W	:	R/W	R/W	R/W	R/W	R/W	R/W	R/W	R/W

EBR1 is an 8-bit register that specifies the flash memory erase area block by block. EBR1 is initialized to H'00 by a power-on reset, in hardware standby mode and software standby mode, when a low level is input to the FWE pin, and when a high level is input to the FWE pin and the SWE1 bit in FLMCR1 is not set. When a bit in EBR1 is set to 1, the corresponding block can be erased. Other blocks are erase-protected. Only one of the bits of EBR1 and EBR2 combined can be set. Do not set more than one bit, as this will cause all the bits in both EBR1 and EBR2 to be automatically cleared to 0. When on-chip flash memory is disabled, a read will return H'00, and writes are invalid.

The flash memory block configuration is shown in table 17.6.

### 17.7.4 Erase Block Register 2 (EBR2)

Bit	:	7	6	5	4	3	2	1	0
		—	—	—	—	—	—	EB9	EB8
Initial value	:	0	0	0	0	0	0	0	0
R/W	:	R/W	R/W	R/W	R/W	R/W	R/W	R/W	R/W

EBR2 is an 8-bit register that specifies the flash memory erase area block by block. EBR2 is initialized to H'00 by a power-on reset, in hardware standby mode and software standby mode, when a low level is input to the FWE pin, and when a high level is input to the FWE pin and the SWE1 bit in FLMCR1 is not set. When a bit in EBR2 is set to 1, the corresponding block can be erased. Other blocks are erase-protected. Only one of the bits of EBR1 and EBR2 combined can be set. Do not set more than one bit, as this will cause all the bits in both EBR1 and EBR2 to be automatically cleared to 0. Bits 7 to 2 are reserved and must only be written with 0. When on-chip flash memory is disabled, a read will return H'00, and writes are invalid.



The flash memory block configuration is shown in table 17.6.

**Table 17.6 Flash Memory Erase Blocks**

<b>Block (Size)</b>	<b>Addresses</b>
EB0 (1 kbyte)	H'000000–H'0003FF
EB1 (1 kbyte)	H'000400–H'0007FF
EB2 (1 kbyte)	H'000800–H'000BFF
EB3 (1 kbyte)	H'000C00–H'000FFF
EB4 (28 kbytes)	H'001000–H'007FFF
EB5 (16 kbytes)	H'008000–H'00BFFF
EB6 (8 kbytes)	H'00C000–H'00DFFF
EB7 (8 kbytes)	H'00E000–H'00FFFF
EB8 (32 kbytes)	H'010000–H'017FFF
EB9 (32 kbytes)	H'018000–H'01FFFF

### 17.7.5 RAM Emulation Register (RAMER)

Bit	:	7	6	5	4	3	2	1	0
		—	—	—	—	RAMS	—	RAM1	RAM0
Initial value	:	0	0	0	0	0	0	0	0
R/W	:	R	R	R	R/W	R/W	R/W	R/W	R/W

RAMER specifies the area of flash memory to be overlapped with part of RAM when emulating real-time flash memory programming. RAMER initialized to H'00 by a power-on reset and in hardware standby mode. It is not initialized in software standby mode. RAMER settings should be made in user mode or user program mode.

Flash memory area divisions are shown in table 17.7. To ensure correct operation of the emulation function, the ROM for which RAM emulation is performed should not be accessed immediately after this register has been modified. Normal execution of an access immediately after register modification is not guaranteed.

**Bits 7 to 5—Reserved:** These bits always read 0.

**Bits 4 and 2—Reserved:** Only 0 may be written to these bits.

**Bit 3—RAM Select (RAMS):** Specifies selection or non-selection of flash memory emulation in RAM. When RAMS = 1, all flash memory block are program/erase-protected.

**Bit 3**

<b>RAMS</b>	<b>Description</b>
0	Emulation not selected (Initial value) Program/erase-protection of all flash memory blocks is disabled
1	Emulation selected Program/erase-protection of all flash memory blocks is enabled

**Bits 1 and 0—Flash Memory Area Selection:** These bits are used together with bit 3 to select the flash memory area to be overlapped with RAM. (See table 17.7.)

**Table 17.7 Flash Memory Area Divisions**

<b>Addresses</b>	<b>Block Name</b>	<b>RAMS</b>	<b>RAM1</b>	<b>RAM0</b>
H'FFD000–H'FFD3FF	RAM area 1 kbyte	0	*	*
H'000000–H'0003FF	EB0 (1 kbyte)	1	0	0
H'000400–H'0007FF	EB1 (1 kbyte)	1	0	1
H'000800–H'000BFF	EB2 (1 kbyte)	1	1	0
H'000C00–H'000FFF	EB3 (1 kbyte)	1	1	1

\*: Don't care

**17.7.6 Flash Memory Power Control Register (FLPWCR)**

Bit:	7	6	5	4	3	2	1	0
	PDWND	—	—	—	—	—	—	—
Initial value:	0	0	0	0	0	0	0	0
R/W:	R/W	R	R	R	R	R	R	R

FLPWCR enables or disables a transition to the flash memory power-down mode when the LSI switches to subactive mode.

FLPWCR is initialized to H'00 by a power-on reset, and in hardware standby mode and software standby mode.

**Bit 7—Power-Down Disable (PDWND):** Enables or disables a transition to the flash memory power-down mode when the LSI switches to subactive mode.

#### Bit 7

PDWND	Description
0	Transition to flash memory power-down mode enabled (Initial value)
1	Transition to flash memory power-down mode disabled

Note: PDWND is valid only when the LSI is in subactive mode or subsleep mode, and is invalid in other modes.

**Bits 6 to 0—Reserved:** These bits always read 0.

### 17.7.7 Serial Control Register X (SCRX)

Bit	:	7	6	5	4	3	2	1	0
		—	—	—	—	FLSHE	—	—	—
Initial value	:	0	0	0	0	0	0	0	0
R/W	:	R/W	R/W	R/W	R/W	R/W	R/W	R/W	R/W

SCRX is an 8-bit readable/writable register that performs on-chip flash memory control.

SCRX is initialized to H'00 by a reset and in hardware standby mode.

**Bits 7 to 4, 2 to 0—Reserved:** Only 0 may be written to these bits.

**Bit 3—Flash Memory Control Register Enable (FLSHE):** Controls CPU access to the flash memory control registers (FLMCR1, FLMCR2, EBR1, and EBR2). Setting the FLSHE bit to 1 enables read/write access to the flash memory control registers. If FLSHE is cleared to 0, the flash memory control registers are deselected. In this case, the flash memory control register contents are retained.

#### Bit 3

FLSHE	Description
0	Flash control registers deselected in area H'FFFA8 to H'FFFAAC (Initial value)
1	Flash control registers selected in area H'FFFA8 to H'FFFAAC

## 17.8 On-Board Programming Modes

When pins are set to on-board programming mode and a reset-start is executed, a transition is made to the on-board programming state in which program/erase/verify operations can be performed on the on-chip flash memory. There are two on-board programming modes: boot mode and user program mode. The pin settings for transition to each of these modes are shown in table 17.8. For a diagram of the transitions to the various flash memory modes, see figure 17.3.

**Table 17.8 Setting On-Board Programming Modes**

Mode		FWE	MD2	MD1	MD0
Boot mode	Expanded mode	1	0	1	0
	Single-chip mode		0	1	1
User program mode	Expanded mode	1	1	1	0
	Single-chip mode		1	1	1

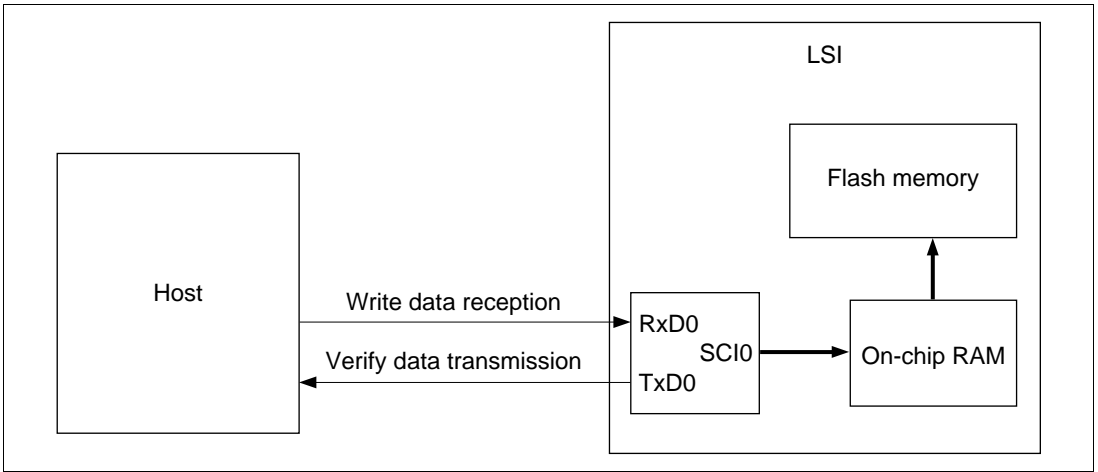
### 17.8.1 Boot Mode

When boot mode is used, the flash memory programming control program must be prepared in the host beforehand. The SCI channel to be used is set to asynchronous mode.

When a reset-start is executed after the LSI's pins have been set to boot mode, the boot program built into the LSI is started and the programming control program prepared in the host is serially transmitted to the LSI via the SCI. In the LSI, the programming control program received via the SCI is written into the programming control program area in on-chip RAM. After the transfer is completed, control branches to the start address of the programming control program area and the programming control program execution state is entered (flash memory programming is performed).

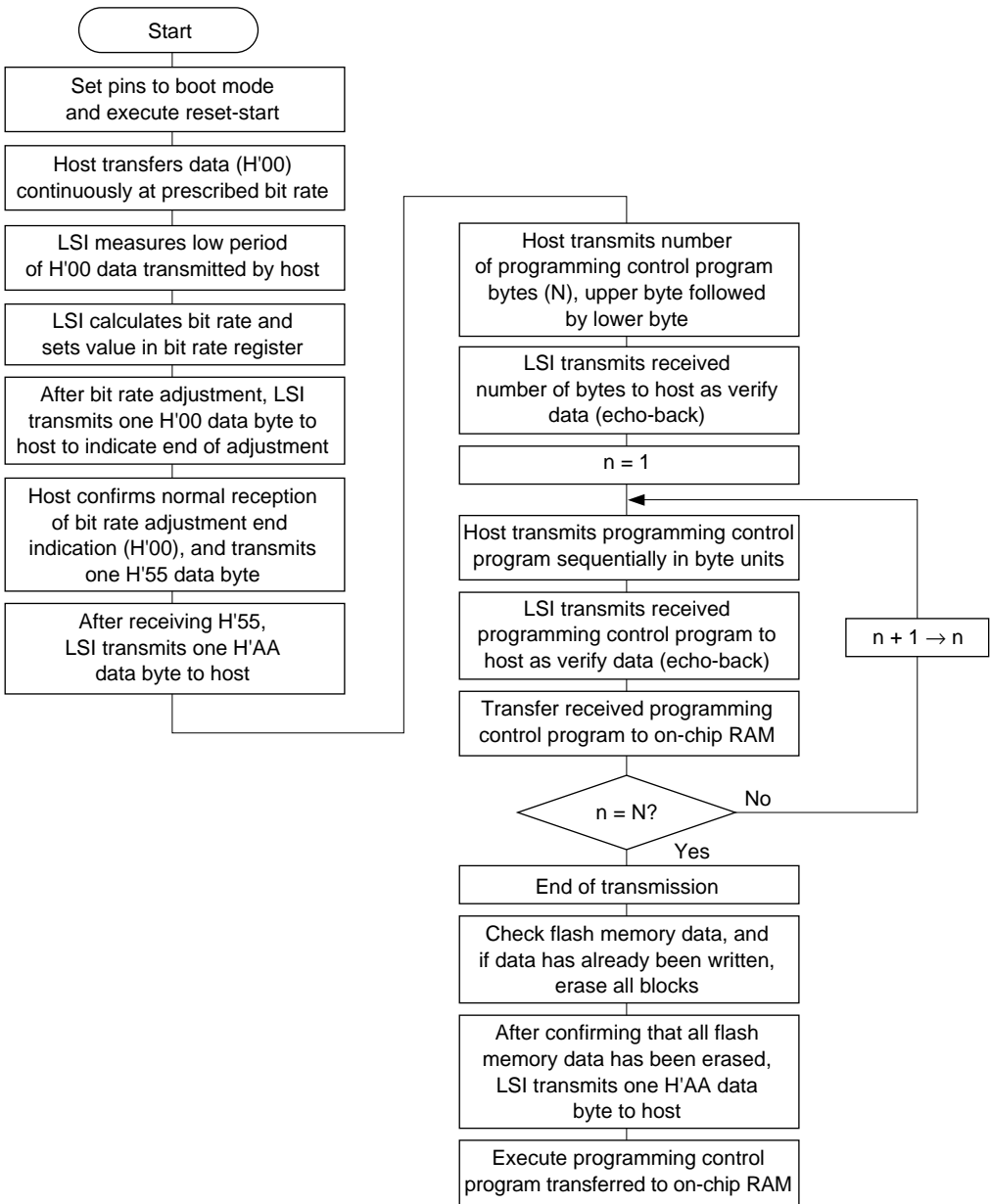
The transferred programming control program must therefore include coding that follows the programming algorithm given later.

The system configuration in boot mode is shown in figure 17.9, and the boot mode execution procedure in figure 17.10.



**Figure 17.9 System Configuration in Boot Mode**

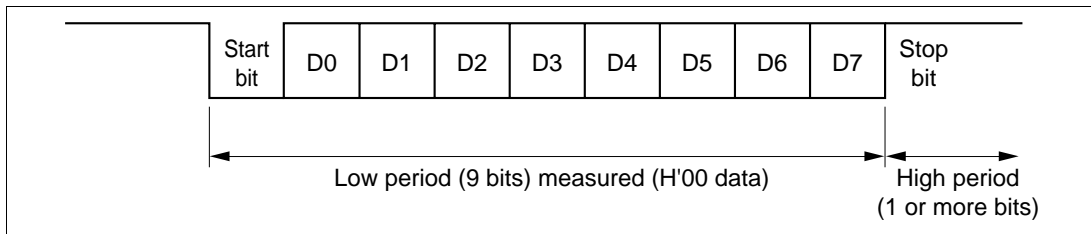
If a memory cell does not operate normally and cannot be erased, one H'FF byte is transmitted as an erase error indication, and the erase operation and subsequent operations are halted. When a transition is made to boot mode, or from boot mode to another mode, mode switching must be carried out by means of  $\overline{\text{RES}}$  input. The states of ports with multiplexed address functions and bus control output signals ( $\overline{\text{AS}}$ ,  $\overline{\text{RD}}$ ,  $\overline{\text{WR}}$ ) change during the switchover period (while a low level is being input at the  $\overline{\text{RES}}$  pin), and therefore these pins should not be used for output signals during this period.



Note: If a memory cell does not operate normally and cannot be erased, one H'FF byte is transmitted as an erase error, and the erase operation and subsequent operations are halted.

**Figure 17.10 Boot Mode Execution Procedure**

## Automatic SCI Bit Rate Adjustment



**Figure 17.11 Automatic SCI Bit Rate Adjustment**

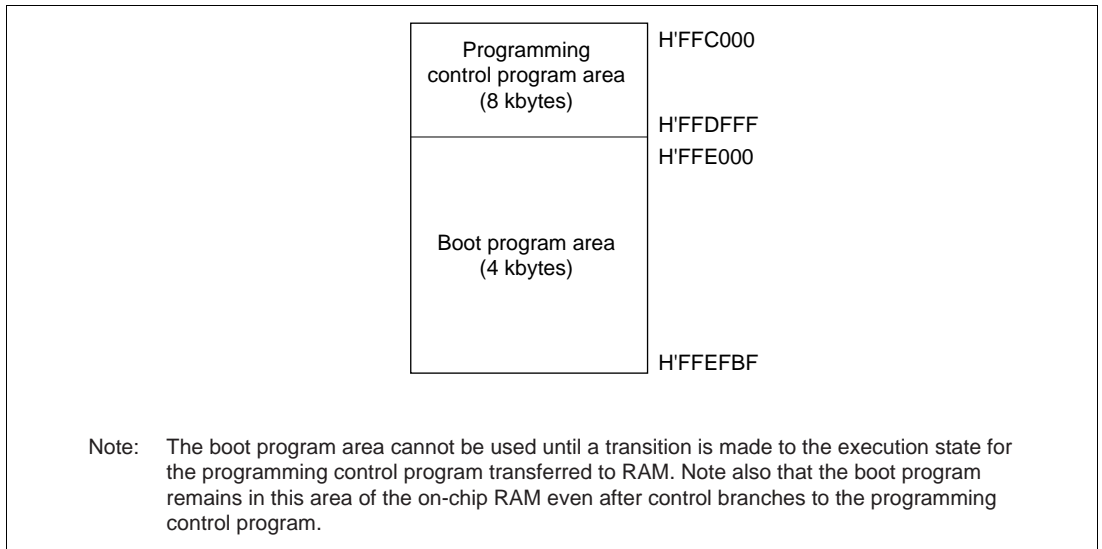
When boot mode is initiated, the LSI measures the low period of the asynchronous SCI communication data (H'00) transmitted continuously from the host. The SCI transmit/receive format should be set as follows: 8-bit data, 1 stop bit, no parity. The LSI calculates the bit rate of the transmission from the host from the measured low period, and transmits one H'00 byte to the host to indicate the end of bit rate adjustment. The host should confirm that this adjustment end indication (H'00) has been received normally, and transmit one H'55 byte to the LSI. If reception cannot be performed normally, initiate boot mode again (reset), and repeat the above operations. Depending on the host's transmission bit rate and the LSI's system clock frequency, there will be a discrepancy between the bit rates of the host and the LSI. Set the host transfer bit rate at 4,800, 9,600, or 19,200 bps to operate the SCI properly.

Table 17.9 shows host transfer bit rates and system clock frequencies for which automatic adjustment of the LSI bit rate is possible. The boot program should be executed within this system clock range.

**Table 17.9 System Clock Frequencies for which Automatic Adjustment of LSI Bit Rate is Possible**

Host Bit Rate	System Clock Frequency for Which Automatic Adjustment of LSI Bit Rate is Possible
4,800 bps	2 MHz to 13.5 MHz
9,600 bps	4 MHz to 13.5 MHz
19,200 bps	8 MHz to 13.5 MHz

**On-Chip RAM Area Divisions in Boot Mode:** In boot mode, the RAM area is divided into an area used by the boot program and an area to which the programming control program is transferred via the SCI, as shown in figure 17.12. The boot program area cannot be used until the execution state in boot mode switches to the programming control program transferred from the host.



**Figure 17.12 RAM Areas in Boot Mode**

**Notes on Use of Boot Mode:**

- When the chip comes out of reset in boot mode, it measures the low-level period of the input at the SCI's RxD0 pin. The reset should end with RxD0 high. After the reset ends, it takes approximately 100 states before the chip is ready to measure the low-level period of the RxD0 pin.
- In boot mode, if any data has been programmed into the flash memory (if all data is not 1), all flash memory blocks are erased. Boot mode is for use when user program mode is unavailable, such as the first time on-board programming is performed, or if the program activated in user program mode is accidentally erased.
- Interrupts cannot be used while the flash memory is being programmed or erased.
- The RxD0 and TxD0 pins should be pulled up on the board.
- Before branching to the programming control program (RAM area H'FFC000), the chip terminates transmit and receive operations by the on-chip SCI (channel 0) (by clearing the RE and TE bits in SCR to 0), but the adjusted bit rate value remains set in BRR. The transmit data output pin, TxD0, goes to the high-level output state (P30DDR = 1, P30DR = 1).



The contents of the CPU's internal general registers are undefined at this time, so these registers must be initialized immediately after branching to the programming control program. In particular, since the stack pointer (SP) is used implicitly in subroutine calls, etc., a stack area must be specified for use by the programming control program.

Initial settings must also be made for all other on-chip registers.

- Boot mode can be entered by making the pin settings shown in table 17.8 and executing a reset-start.

Boot mode can be cleared by driving the reset pin low, waiting at least 20 states, then setting the FWE pin and mode pins, and executing reset release\*<sup>1</sup>. Boot mode can also be cleared by a WDT overflow reset.

Do not change the mode pin input levels in boot mode, and do not drive the FWE pin low while the boot program is being executed or while flash memory is being programmed or erased\*<sup>2</sup>.

- If the mode pin input levels are changed (for example, from low to high) during a reset, the state of ports with multiplexed address functions and bus control output pins ( $\overline{AS}$ ,  $\overline{RD}$ ,  $\overline{HWR}$ ) will change according to the change in the microcomputer's operating mode\*<sup>3</sup>.

Therefore, care must be taken to make pin settings to prevent these pins from becoming output signal pins during a reset, or to prevent collision with signals outside the microcomputer.

Notes: \*1 Mode pin and FWE pin input must satisfy the mode programming setup time ( $t_{MDS} = 200$  ns) with respect to the reset release timing.

\*2 For further information on FWE application and disconnection, see section 17.15, Flash Memory Programming and Erasing Precautions.

\*3 See appendix D, Pin States.

## 17.8.2 User Program Mode

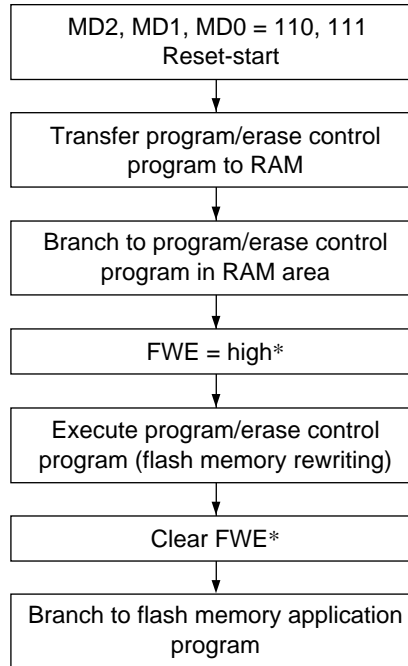
When set to user program mode, the chip can program and erase its flash memory by executing a user program/erase control program. Therefore, on-board reprogramming of the on-chip flash memory can be carried out by providing on-board means of FWE control and supply of programming data, and storing a program/erase control program in part of the program area as necessary.

To select user program mode, select a mode that enables the on-chip flash memory (mode 6 or 7), and apply a high level to the FWE pin. In this mode, on-chip supporting modules other than flash memory operate as they normally would in modes 6 and 7.

The flash memory itself cannot be read while the SWE1 bit is set to 1 to perform programming or erasing, so the control program that performs programming and erasing should be run in on-chip RAM or external memory.

Figure 17.13 shows the procedure for executing the program/erase control program when transferred to on-chip RAM.

Write the FWE assessment program and transfer program (and the program/erase control program if necessary) beforehand



Notes: Do not apply a constant high level to the FWE pin. Apply a high level to the FWE pin only when the flash memory is programmed or erased. Also, while a high level is applied to the FWE pin, the watchdog timer should be activated to prevent overprogramming or overerasing due to program runaway, etc.

\* For further information on FWE application and disconnection, see section 17.15, Flash Memory Programming and Erasing Precautions.

**Figure 17.13 User Program Mode Execution Procedure**

## 17.9 Programming/Erasing Flash Memory

A software method, using the CPU, is employed to program and erase flash memory in the on-board programming modes. There are four flash memory operating modes: program mode, erase mode, program-verify mode, and erase-verify mode. Transitions to these modes are made by setting the PSU1, ESU1, P1, E1, PV1, and EV1 bits in FLMCR1 for addresses H'000000 to H'01FFFF.

The flash memory cannot be read while it is being written or erased. Install the program to control flash memory programming and erasing (programming control program) in the on-chip RAM, in external memory, and execute the program from there.

- Notes:
1. Operation is not guaranteed if bits SWE1, ESU1, PSU1, EV1, PV1, E1, and P1 of FLMCR1 are set/reset by a program in flash memory in the corresponding address areas.
  2. When programming or erasing, set FWE to 1 (programming/erasing will not be executed if FWE = 0).
  3. Programming should be performed in the erased state. Do not perform additional programming on previously programmed addresses.

### 17.9.1 Program Mode

Follow the procedure shown in the program/program-verify flowchart in figure 17.14 to write data or programs to flash memory. Performing program operations according to this flowchart will enable data or programs to be written to flash memory without subjecting the device to voltage stress or sacrificing program data reliability. Programming should be carried out 128 bytes at a time.

For the wait times ( $t_{sswe}$ ,  $t_{sp10}$ ,  $t_{sp30}$ ,  $t_{sp200}$ ,  $t_{cp}$ ,  $t_{cpsu}$ ,  $t_{spv}$ ,  $t_{spvr}$ ,  $t_{cpv}$ ,  $t_{cswe}$ ) after bits are set or cleared in flash memory control register 1 (FLMCR1) and the maximum number of programming operations (N), see 20.2.5, Flash Memory Characteristics.

Following the elapse of ( $t_{sswe}$ )  $\mu$ s or more after the SWE1 bit is set to 1 in flash memory control register 1 (FLMCR1), 128-byte data is stored in the program data area and reprogram data area, and the 128-byte data in the program data area in RAM is written consecutively to the write addresses. The lower 8 bits of the first address written to must be H'00 or H'80. 128 consecutive byte data transfers are performed. The program address and program data are latched in the flash memory. A 128-byte data transfer must be performed even if writing fewer than 128 bytes; in this case, H'FF data must be written to the extra addresses.

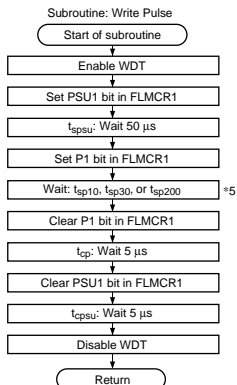
Next, the watchdog timer is set to prevent overprogramming in the event of program runaway, etc. Set a value greater than ( $t_{sp10} + t_{sp200} + t_{cp} + t_{cpsu}$ )  $\mu$ s as the WDT overflow period. After this, preparation for program mode (program setup) is carried out by setting the PSU1 bit in FLMCR1, and after the elapse of ( $t_{sp10}$ )  $\mu$ s or more, the operating mode is switched to program mode by

setting the P1 bit in FLMCR1. The time during which the P1 bit is set is the flash memory programming time. Set the programming time according to the table in the programming flowchart.

## 17.9.2 Program-Verify Mode

In program-verify mode, the data written in program mode is read to check whether it has been correctly written in the flash memory.

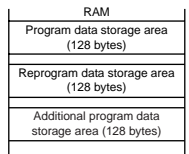
After the elapse of a given programming time, the programming mode is exited (the P1 bit in FLMCR1 is cleared, then the PSU1 bit is cleared at least ( $t_{cp}$ )  $\mu$ s later). The watchdog timer is cleared after the elapse of ( $t_{cpsu}$ )  $\mu$ s or more, and the operating mode is switched to program-verify mode by setting the PV1 bit in FLMCR1. Before reading in program-verify mode, a dummy write of H'FF data should be made to the addresses to be read. The dummy write should be executed after the elapse of ( $t_{spv}$ )  $\mu$ s or more. When the flash memory is read in this state (verify data is read in 16-bit units), the data at the latched address is read. Wait at least ( $t_{spvr}$ )  $\mu$ s after the dummy write before performing this read operation. Next, the originally written data is compared with the verify data, and reprogram data is computed (see figure 17.14) and transferred to the reprogram data area. After 128 bytes of data have been verified, exit program-verify mode, wait for at least ( $t_{cpv}$ )  $\mu$ s, then clear the SWE1 bit in FLMCR1 to 0. If reprogramming is necessary, set program mode again, and repeat the program/program-verify sequence as before. However, ensure that the program/program-verify sequence is not repeated more than (N) times on the same bits.



Note: \*6 Write Pulse Width

Number of Writes n	Write Time (t <sub>sp30</sub> /t <sub>sp200</sub> )μs
1	t <sub>sp30</sub>
2	t <sub>sp30</sub>
3	t <sub>sp30</sub>
4	t <sub>sp30</sub>
5	t <sub>sp30</sub>
6	t <sub>sp30</sub>
7	t <sub>sp30</sub>
8	t <sub>sp200</sub>
9	t <sub>sp200</sub>
10	t <sub>sp200</sub>
11	t <sub>sp200</sub>
12	t <sub>sp200</sub>
13	t <sub>sp200</sub>
...	...
998	t <sub>sp200</sub>
999	t <sub>sp200</sub>
1000	t <sub>sp200</sub>

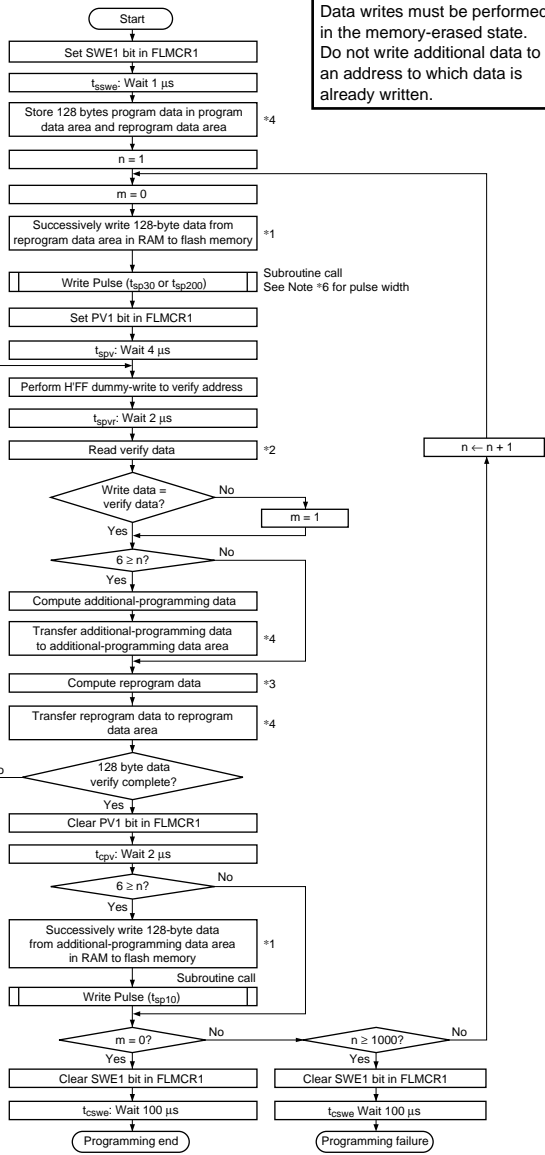
Note: Use a t<sub>sp10</sub> write pulse for additional programming.



- Notes: \*1 Transfer data in byte units. The lower eight bits of the start address to which data is written must be H'00 or H'80. Transfer 128-byte data even when writing fewer than 128 bytes. In this case, Set HFF in unused addresses.
- \*2 Read verify data in word form (16 bits).
- \*3 Even for bits to which data is already written, an additional write should be performed if their verify result is NG.
- \*4 A 128-byte area for storing program data, a 128-byte area for storing reprogram data, and a 128-byte area for storing additional program data must be provided in RAM. The reprogram and additional program data contents are modified as programming proceeds.
- \*5 A write pulse of t<sub>sp30</sub> or t<sub>sp200</sub> is applied according to the progress of the programming operation. See Note 6 for the pulse widths. When writing of the additional program data is executed, a t<sub>sp10</sub> write pulse should be applied. Reprogram data 'X' means reprogram data when the pulse is applied.

Reprogram Data Computation Table

Original Data (D)	Verify Data (V)	Reprogram Data (X)	Comments
0	0	1	Programming complete.
0	1	0	Programming is incomplete; reprogramming should be performed.
1	0	1	—
1	1	1	Left in the erased state.



Data writes must be performed in the memory-erased state. Do not write additional data to an address to which data is already written.

Additional-Programming Data Computation Table

Reprogram Data (X)	Verify Data (V)	Additional-Programming Data (Y)	Comments
0	0	0	Additional programming executed
0	1	1	Additional programming not executed
1	0	1	Additional programming not executed
1	1	1	Additional programming not executed

Figure 17.14 Program/Program-Verify Flowchart

### 17.9.3 Erase Mode

Flash memory erasing should be performed block by block following the procedure shown in the erase/erase-verify flowchart (single-block erase) shown in figure 17.15.

For the wait times ( $t_{sswe}$ ,  $t_{sesu}$ ,  $t_{se}$ ,  $t_{ce}$ ,  $t_{cesu}$ ,  $t_{sev}$ ,  $t_{sevr}$ ,  $t_{cev}$ ,  $t_{cswe}$ ) after bits are set or cleared in flash memory control register 1 (FLMCR1) and the maximum number of erase operations (N), see 20.2.5, Flash Memory Characteristics.

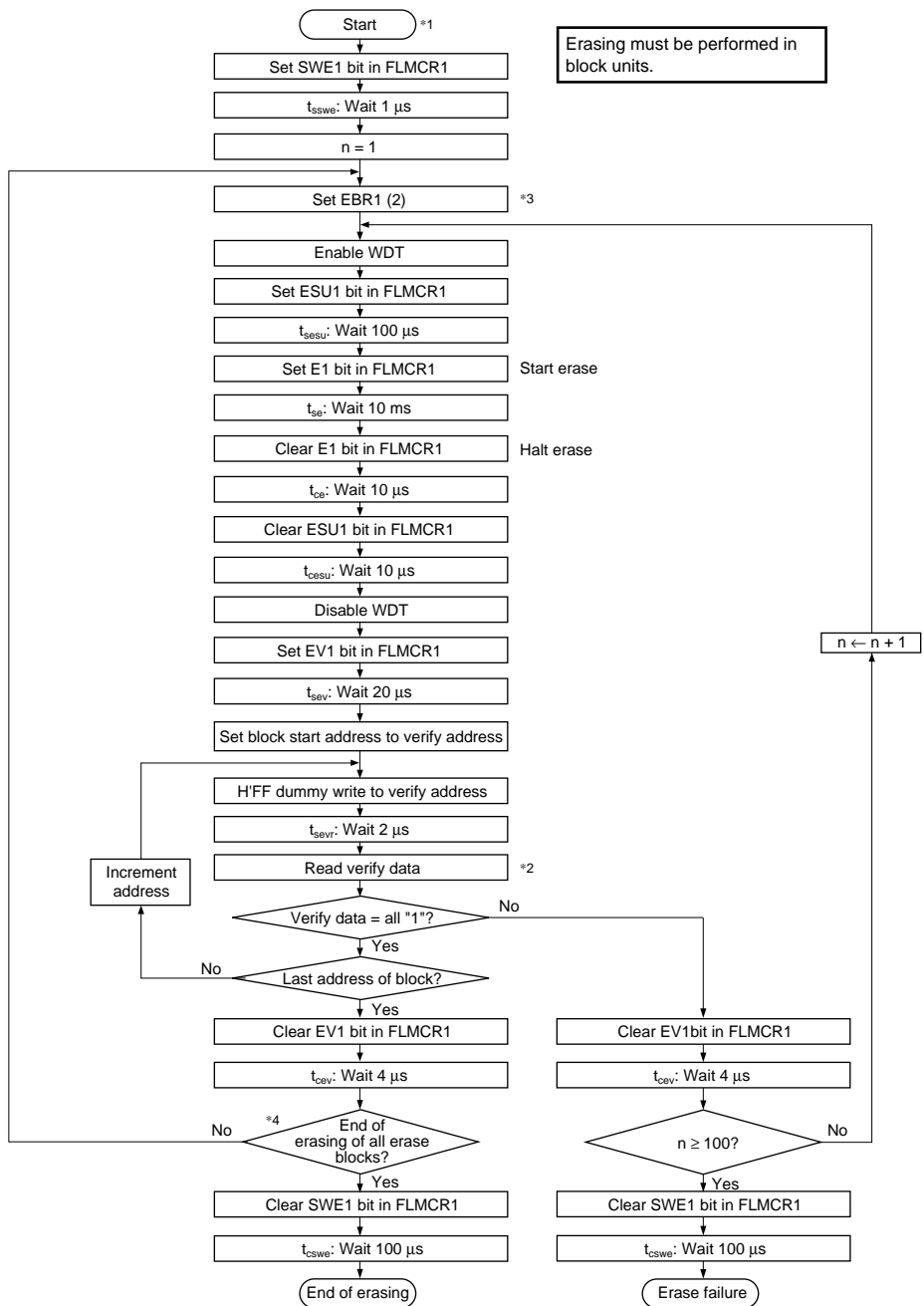
To perform data or program erasure, make a 1-bit setting for the flash memory area to be erased in erase block register 1 or 2 (EBR1 or EBR2) at least ( $t_{sswe}$ )  $\mu$ s after setting the SWE1 bit to 1 in flash memory control register 1 (FLMCR1). Next, set up the watchdog timer to prevent overerasing in the event of program runaway, etc. Set a value greater than ( $t_{sesu} + t_{se} + t_{ce} + t_{cesu}$ ) ms as the WDT overflow period. After this, preparation for erase mode (erase setup) is carried out by setting the ESU1 bit in FLMCR1, and after the elapse of ( $t_{sesu}$ )  $\mu$ s or more, the operating mode is switched to erase mode by setting the E1 bit in FLMCR1. The time during which the E1 bit is set is the flash memory erase time. Ensure that the erase time does not exceed ( $t_{se}$ ) ms.

Note: With flash memory erasing, prewriting (setting all data in the memory to be erased to 0) is not necessary before starting the erase procedure.

### 17.9.4 Erase-Verify Mode

In erase-verify mode, data is read after memory has been erased to check whether it has been correctly erased.

After the elapse of the erase time, erase mode is exited (the E1 bit in FLMCR1 is cleared to 0, then the ESU1 bit is cleared to 0 at least ( $t_{ce}$ )  $\mu$ s later), the watchdog timer is cleared after the elapse of ( $t_{cesu}$ )  $\mu$ s or more, and the operating mode is switched to erase-verify mode by setting the EV1 bit in FLMCR1. Before reading in erase-verify mode, a dummy write of H'FF data should be made to the addresses to be read. The dummy write should be executed after the elapse of ( $t_{sev}$ )  $\mu$ s or more. When the flash memory is read in this state (verify data is read in 16-bit units), the data at the latched address is read. Wait at least ( $t_{sevr}$ )  $\mu$ s after the dummy write before performing this read operation. If the read data has been erased (all 1), execute a dummy write to the next address, and perform an erase-verify. If the read data has not been erased, set erase mode again and repeat the erase/erase-verify sequence as before. However, ensure that the erase/erase-verify sequence is not repeated more than (N) times. When verification is completed, exit erase-verify mode, and wait for at least ( $t_{cev}$ )  $\mu$ s. If erasure has been completed on all the erase blocks, clear the SWE1 bit in FLMCR1. If there are any unerased blocks, make a 1-bit setting for the flash memory block to be erased, and repeat the erase/erase-verify sequence as before.



- Notes: \*1 Preprogramming (setting erase block data to all "0") is not necessary.  
 \*2 Verify data is read in 16-bit (word) units.  
 \*3 Set only one bit in EBR1 (2). More than one bit cannot be set.  
 \*4 Erasing is performed in block units. To erase a number of blocks, each block must be erased in turn.

Figure 17.15 Erase/Eraser-Verify Flowchart

## 17.10 Protection

There are three kinds of flash memory program/erase protection: hardware protection, software protection, and error protection.

### 17.10.1 Hardware Protection

Hardware protection refers to a state in which programming/erasing of flash memory is forcibly disabled or aborted. Hardware protection is reset by settings in flash memory control register 1 (FLMCR1), flash memory control register 2 (FLMCR2), erase block register 1 (EBR1), and erase block register 2 (EBR2). The FLMCR1, FLMCR2, EBR1, and EBR2 settings are retained in the error-protected state. (See table 17.10.)

**Table 17.10 Hardware Protection**

Item	Description	Functions	
		Program	Erase
FWE pin protection	<ul style="list-style-type: none"><li>When a low level is input to the FWE pin, FLMCR1, FLMCR2, (except bit FLER) EBR1, and EBR2 are initialized, and the program/erase-protected state is entered.</li></ul>	Yes	Yes
Reset/standby protection	<ul style="list-style-type: none"><li>In a power-on reset (including a WDT power-on reset) and in standby mode, FLMCR1, FLMCR2, EBR1, and EBR2 are initialized, and the program/erase-protected state is entered.</li><li>In a reset via the <math>\overline{\text{RES}}</math> pin, the reset state is not entered unless the <math>\overline{\text{RES}}</math> pin is held low until oscillation stabilizes after powering on. In the case of a reset during operation, hold the <math>\overline{\text{RES}}</math> pin low for the <math>\overline{\text{RES}}</math> pulse width specified in the AC Characteristics section.</li></ul>	Yes	Yes



## 17.10.2 Software Protection

Software protection can be implemented by setting the SWE1 bit in FLMCR1, erase block register 1 (EBR1), erase block register 2 (EBR2), and the RAMS bit in the RAM emulation register (RAMER). When software protection is in effect, setting the P1 or E1 bit in flash memory control register 1 (FLMCR1), does not cause a transition to program mode or erase mode. (See table 17.11.)

**Table 17.11 Software Protection**

Item	Description	Functions	
		Program	Erase
SWE bit protection	<ul style="list-style-type: none"><li>Setting bit SWE1 in FLMCR1 to 0 will place area H'000000 to H'01FFFF in the program/erase-protected state. (Execute the program in the on-chip RAM, external memory)</li></ul>	Yes	Yes
Block specification protection	<ul style="list-style-type: none"><li>Erase protection can be set for individual blocks by settings in erase block register 1 (EBR1) and erase block register 2 (EBR2).</li><li>Setting EBR1 and EBR2 to H'00 places all blocks in the erase-protected state.</li></ul>	—	Yes
Emulation protection	<ul style="list-style-type: none"><li>Setting the RAMS bit to 1 in the RAM emulation register (RAMER) places all blocks in the program/erase-protected state.</li></ul>	Yes	Yes

### 17.10.3 Error Protection

In error protection, an error is detected when LSI runaway occurs during flash memory programming/erasing, or operation is not performed in accordance with the program/erase algorithm, and the program/erase operation is aborted. Aborting the program/erase operation prevents damage to the flash memory due to overprogramming or overerasing.

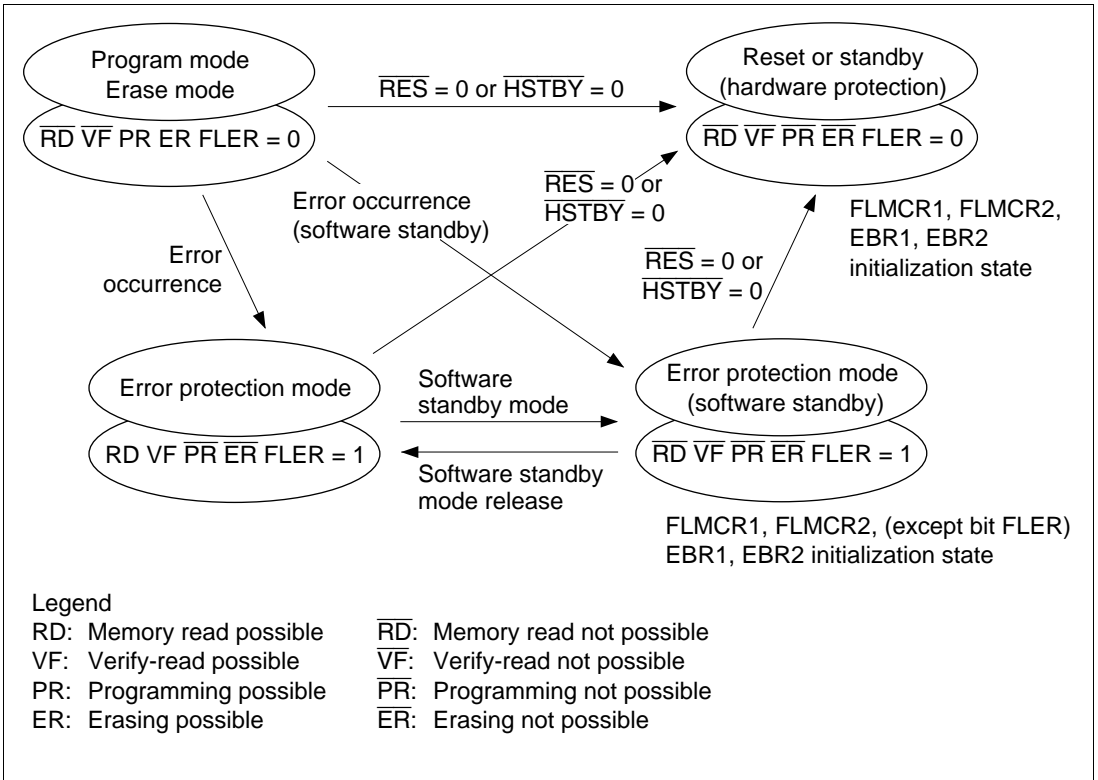
If the LSI malfunctions during flash memory programming/erasing, the FLER bit is set to 1 in FLMCR2 and the error protection state is entered. The FLMCR1, FLMCR2, EBR1, and EBR2 settings are retained, but program mode or erase mode is aborted at the point at which the error occurred. Program mode or erase mode cannot be re-entered by re-setting the P1 or E1 bit. However, PV1 and EV1 bit setting is enabled, and a transition can be made to verify mode.

FLER bit setting conditions are as follows:

1. When the flash memory of the relevant address area is read during programming/erasing (including vector read and instruction fetch)
2. Immediately after exception handling (excluding a reset) during programming/erasing
3. When a SLEEP instruction (including software standby) is executed during programming/erasing
4. When the CPU releases the bus to the DTC during programming/erasing.

Error protection is released only by a power-on reset and in hardware standby mode.

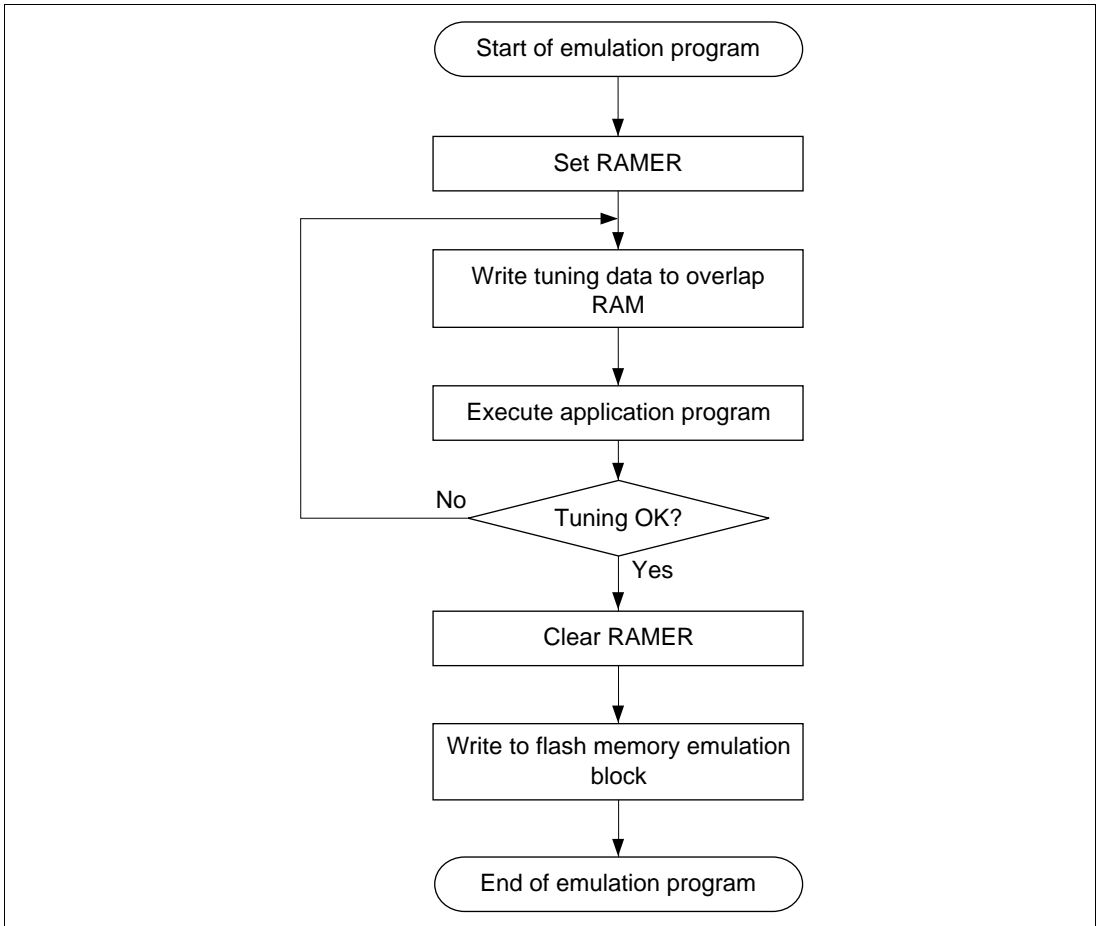
Figure 17.16 shows the flash memory state transition diagram.



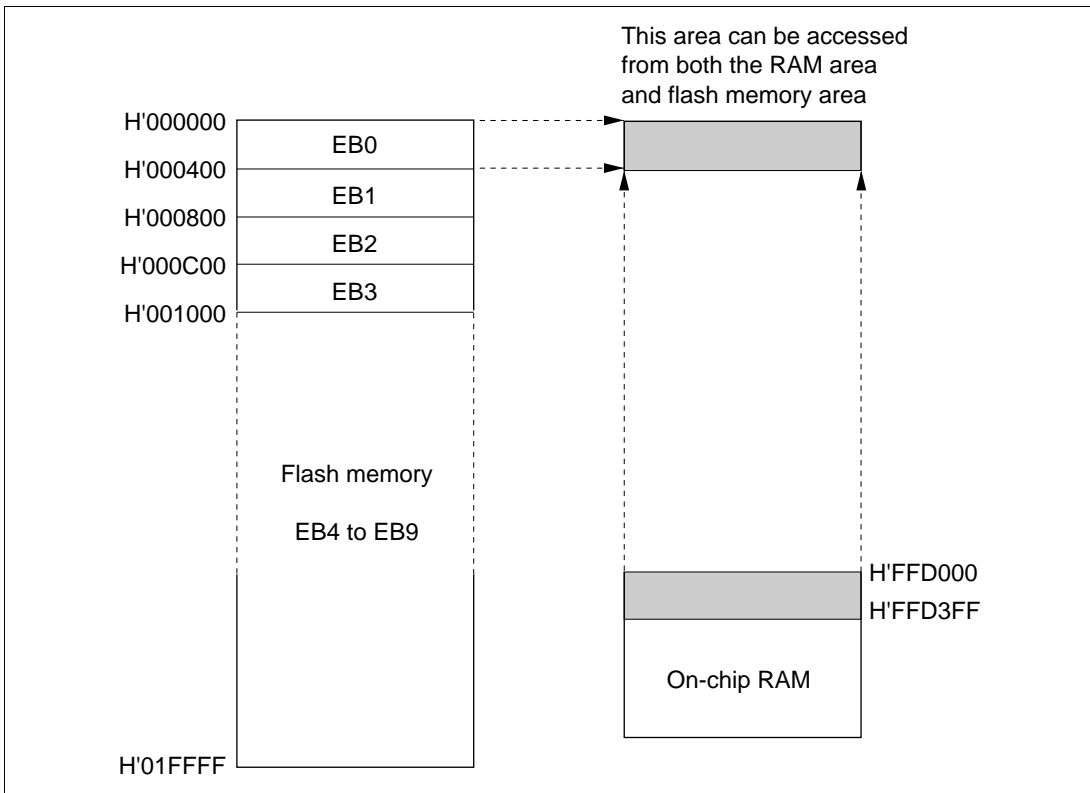
**Figure 17.16 Flash Memory State Transitions**

## 17.11 Flash Memory Emulation in RAM

Making a setting in the RAM emulation register (RAMER) enables part of RAM to be overlapped onto the flash memory area so that data to be written to flash memory can be emulated in RAM in real time. After the RAMER setting has been made, accesses can be made from the flash memory area or the RAM area overlapping flash memory. Emulation can be performed in user mode and user program mode. Figure 17.17 shows an example of emulation of real-time flash memory programming.



**Figure 17.17 Flowchart for Flash Memory Emulation in RAM**



**Figure 17.18 Example of RAM Overlap Operation**

### Example in which Flash Memory Block Area EB0 is Overlapped

1. Set bits RAMS, RAM1, and RAM0 in RAMER to 1, 0, 0, to overlap part of RAM onto the area (EB0) for which real-time programming is required.
2. Real-time programming is performed using the overlapping RAM.
3. After the program data has been confirmed, the RAMS bit is cleared, releasing RAM overlap.
4. The data written in the overlapping RAM is written into the flash memory space (EB0).

- Notes:
1. When the RAMS bit is set to 1, program/erase protection is enabled for all blocks regardless of the value of RAM1 and RAM0 (emulation protection). In this state, setting the P1 or E1 bit in flash memory control register 1 (FLMCR1), will not cause a transition to program mode or erase mode. When actually programming or erasing a flash memory area, the RAMS bit should be cleared to 0.
  2. A RAM area cannot be erased by execution of software in accordance with the erase algorithm while flash memory emulation in RAM is being used.
  3. Block area EB0 contains the vector table. When performing RAM emulation, the vector table is needed in the overlap RAM.

## 17.12 Interrupt Handling when Programming/Erasing Flash Memory

All interrupts, including NMI interrupt is disabled when flash memory is being programmed or erased (when the P1 or E1 bit is set in FLMCR1), and while the boot program is executing in boot mode\*<sup>1</sup>, to give priority to the program or erase operation. There are three reasons for this:

1. Interrupt during programming or erasing might cause a violation of the programming or erasing algorithm, with the result that normal operation could not be assured.
2. In the interrupt exception handling sequence during programming or erasing, the vector would not be read correctly\*<sup>2</sup>, possibly resulting in MCU runaway.
3. If interrupt occurred during boot program execution, it would not be possible to execute the normal boot mode sequence.

For these reasons, in on-board programming mode alone there are conditions for disabling interrupt, as an exception to the general rule. However, this provision does not guarantee normal erasing and programming or MCU operation. All requests, including NMI interrupt, must therefore be restricted inside and outside the MCU when programming or erasing flash memory. NMI interrupt is also disabled in the error-protection state while the P1 or E1 bit remains set in FLMCR1.

Notes: \*1 Interrupt requests must be disabled inside and outside the MCU until the programming control program has completed programming.

\*2 The vector may not be read correctly in this case for the following two reasons:

- If flash memory is read while being programmed or erased (while the P1 or E1 bit is set in FLMCR1), correct read data will not be obtained (undetermined values will be returned).
- If the interrupt entry in the vector table has not been programmed yet, interrupt exception handling will not be executed correctly.

## 17.13 Flash Memory Programmer Mode

Programs and data can be written and erased in programmer mode as well as in the on-board programming modes. In programmer mode, flash memory read mode, auto-program mode, auto-erase mode, and status read mode are supported. In auto-program mode, auto-erase mode, and status read mode, a status polling procedure is used, and in status read mode, detailed internal signals are output after execution of an auto-program or auto-erase operation.

In programmer mode, set the mode pins to programmer mode (see table 17.12) and input a 12 MHz input clock.

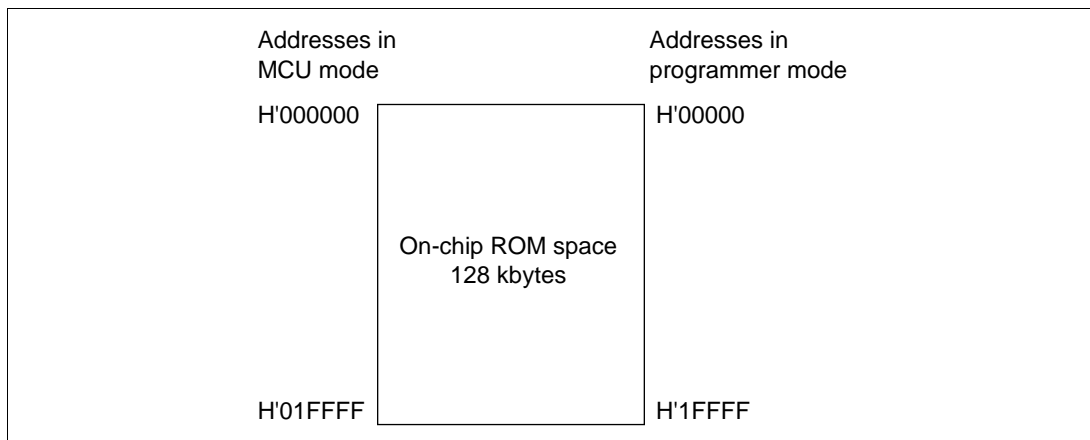
Table 17.12 shows the pin settings for programmer mode. For the pin names in programmer mode, see section 1.3.2, Pin Functions in Each Operating Mode.

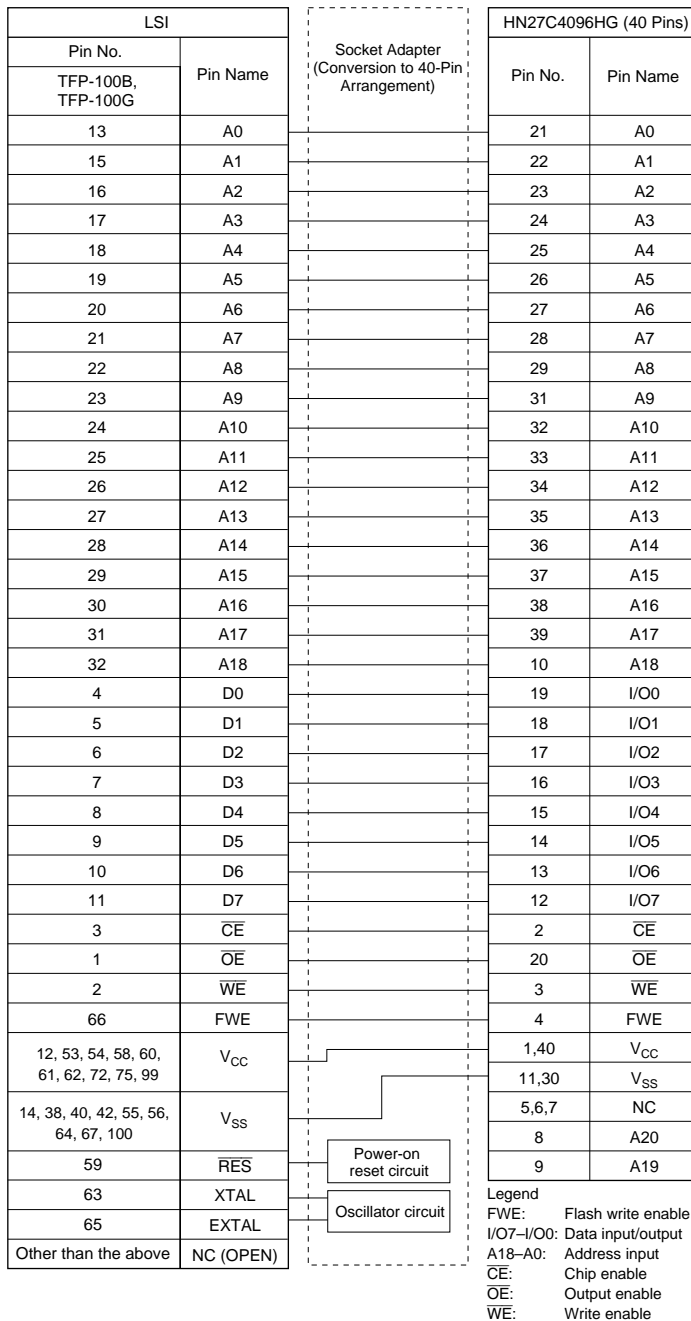
**Table 17.12 Programmer Mode Pin Settings**

<b>Pin Names</b>	<b>Settings</b>
Mode pins: MD2, MD1, MD0	Low level input to MD2, MD1, and MD0.
Mode setting pins: PF3, PF0, P16, P14	High level input to PF3 and PF0, low level input to P16 and P14
FWE pin	High level input (in auto-program and auto-erase modes)
$\overline{\text{RES}}$ pin	Power-on reset circuit
XTAL, EXTAL pins	Oscillator circuit

### 17.13.1 Socket Adapter Pin Correspondence Diagram

Connect the socket adapter to the chip as shown in figure 17.20. This will enable conversion to a 40-pin arrangement. The on-chip ROM memory map is shown in figure 17.19, and the socket adapter pin correspondence diagram in figure 17.20.

**Figure 17.19 On-Chip ROM Memory Map**



**Figure 17.20 Socket Adapter Pin Correspondence Diagram**



### 17.13.2 Programmer Mode Operation

Table 17.13 shows how the different operating modes are set when using programmer mode, and table 17.14 lists the commands used in programmer mode. Details of each mode are given below.

- **Memory Read Mode**  
Memory read mode supports byte reads.
- **Auto-Program Mode**  
Auto-program mode supports programming of 128 bytes at a time. Status polling is used to confirm the end of auto-programming.
- **Auto-Erase Mode**  
Auto-erase mode supports automatic erasing of the entire flash memory. Status polling is used to confirm the end of auto-programming.
- **Status Read Mode**  
Status polling is used for auto-programming and auto-erasing, and normal termination can be confirmed by reading the I/O6 signal. In status read mode, error information is output if an error occurs.

**Table 17.13 Settings for Various Operating Modes In Programmer Mode**

Mode	Pin Names					
	FWE	$\overline{\text{CE}}$	$\overline{\text{OE}}$	$\overline{\text{WE}}$	I/O7– I/O0	A18–A0
Read	H or L	L	L	H	Data output	Ain
Output disable	H or L	L	H	H	Hi-z	X
Command write	H or L	L	H	L	Data input	*Ain
Chip disable	H or L	H	X	X	Hi-z	X

- Notes:
1. Chip disable is not a standby state; internally, it is an operation state.
  2. \*Ain indicates that there is also address input in auto-program mode.
  3. For command writes in auto-program and auto-erase modes, input a high level to the FWE pin.

**Table 17.14 Programmer Mode Commands**

Command Name	Number of Cycles	1st Cycle			2nd Cycle		
		Mode	Address	Data	Mode	Address	Data
Memory read mode	1 + n	Write	X	H'00	Read	RA	Dout
Auto-program mode	129	Write	X	H'40	Write	WA	Din
Auto-erase mode	2	Write	X	H'20	Write	X	H'20
Status read mode	2	Write	X	H'71	Write	X	H'71

Notes: 1. In auto-program mode, 129 cycles are required for command writing by a simultaneous 128-byte write.

2. In memory read mode, the number of cycles depends on the number of address write cycles (n).

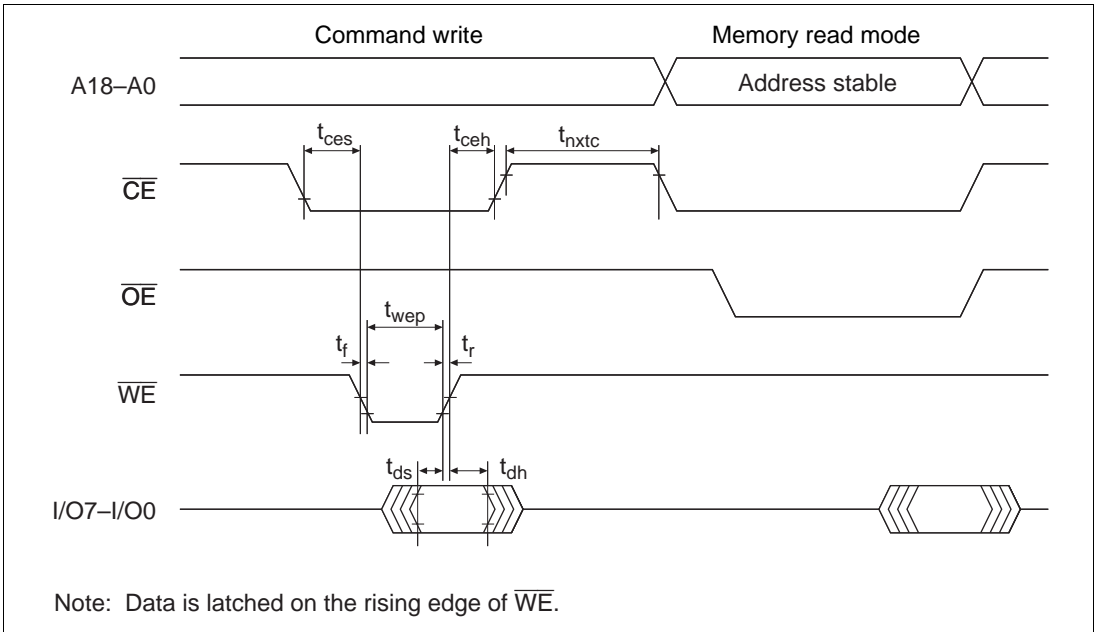
### 17.13.3 Memory Read Mode

1. After completion of auto-program/auto-erase/status read operations, a transition is made to the command wait state. When reading memory contents, a transition to memory read mode must first be made with a command write, after which the memory contents are read.
2. In memory read mode, command writes can be performed in the same way as in the command wait state.
3. Once memory read mode has been entered, consecutive reads can be performed.
4. After powering on, memory read mode is entered.

**Table 17.15 AC Characteristics in Transition to Memory Read Mode**

(Conditions:  $V_{CC} = 3.3\text{ V} \pm 0.3\text{ V}$ ,  $V_{SS} = 0\text{ V}$ ,  $T_a = 25^\circ\text{C} \pm 5^\circ\text{C}$ )

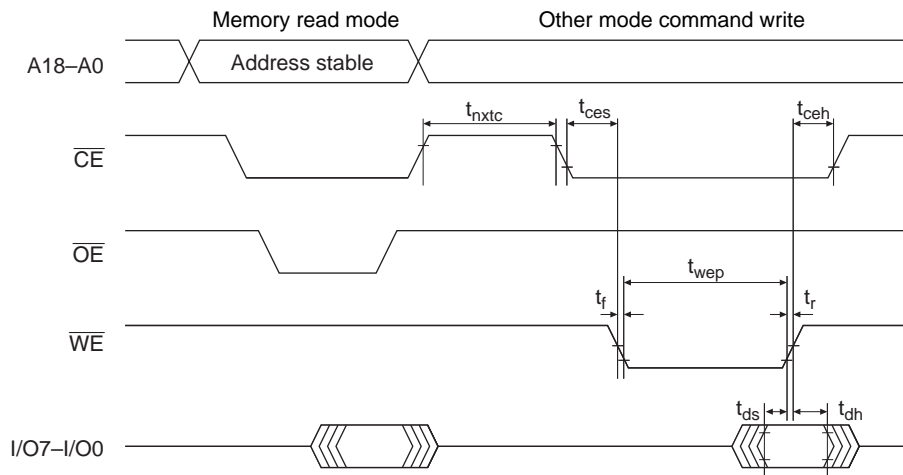
Item	Symbol	Min	Max	Unit
Command write cycle	$t_{nxtc}$	20	—	$\mu\text{s}$
$\overline{\text{CE}}$ hold time	$t_{ceh}$	0	—	ns
$\overline{\text{CE}}$ setup time	$t_{ces}$	0	—	ns
Data hold time	$t_{dh}$	50	—	ns
Data setup time	$t_{ds}$	50	—	ns
Write pulse width	$t_{wep}$	70	—	ns
$\overline{\text{WE}}$ rise time	$t_r$	—	30	ns
$\overline{\text{WE}}$ fall time	$t_f$	—	30	ns



**Figure 17.21 Timing Waveforms for Memory Read after Memory Write**

**Table 17.16 AC Characteristics in Transition from Memory Read Mode to Another Mode**  
 (Conditions:  $V_{CC} = 3.3\text{ V} \pm 0.3\text{ V}$ ,  $V_{SS} = 0\text{ V}$ ,  $T_a = 25^\circ\text{C} \pm 5^\circ\text{C}$ )

Item	Symbol	Min	Max	Unit
Command write cycle	$t_{nxtc}$	20	—	$\mu\text{s}$
$\overline{CE}$ hold time	$t_{ceh}$	0	—	ns
$\overline{CE}$ setup time	$t_{ces}$	0	—	ns
Data hold time	$t_{dh}$	50	—	ns
Data setup time	$t_{ds}$	50	—	ns
Write pulse width	$t_{wep}$	70	—	ns
$\overline{WE}$ rise time	$t_r$	—	30	ns
$\overline{WE}$ fall time	$t_f$	—	30	ns

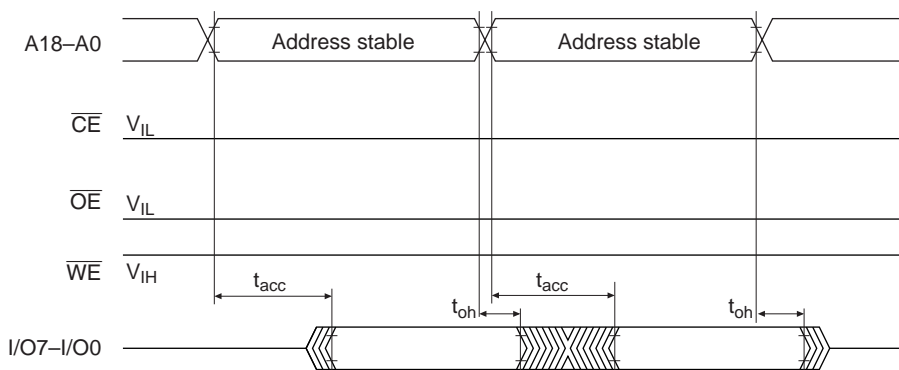


Note: Do not enable  $\overline{WE}$  and  $\overline{OE}$  at the same time.

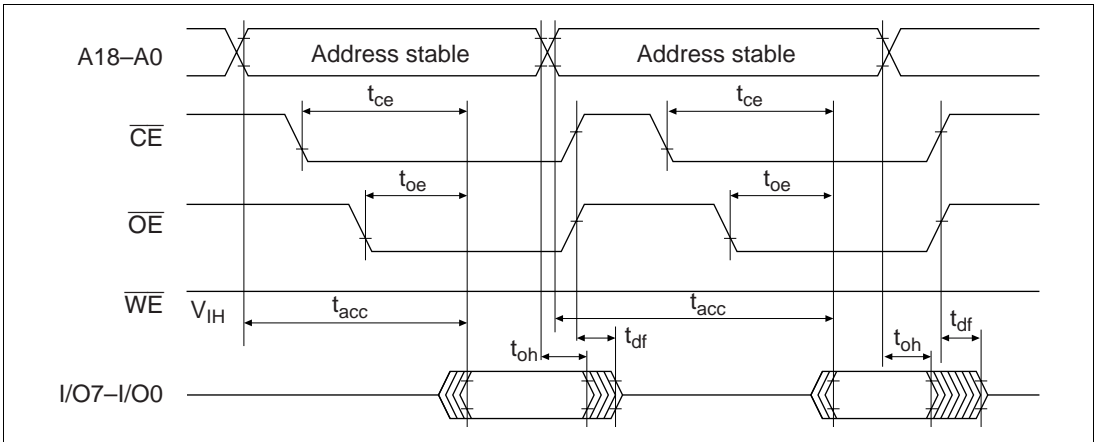
**Figure 17.22 Timing Waveforms in Transition from Memory Read Mode to Another Mode**

**Table 17.17 AC Characteristics in Memory Read Mode (Conditions:  $V_{CC} = 3.3\text{ V} \pm 0.3\text{ V}$ ,  $V_{SS} = 0\text{ V}$ ,  $T_a = 25^\circ\text{C} \pm 5^\circ\text{C}$ )**

Item	Symbol	Min	Max	Unit
Access time	$t_{acc}$	—	20	$\mu\text{s}$
$\overline{CE}$ output delay time	$t_{ce}$	—	150	ns
$\overline{OE}$ output delay time	$t_{oe}$	—	150	ns
Output disable delay time	$t_{df}$	—	100	ns
Data output hold time	$t_{oh}$	5	—	ns



**Figure 17.23  $\overline{CE}$  and  $\overline{OE}$  Enable State Read Timing Waveforms**



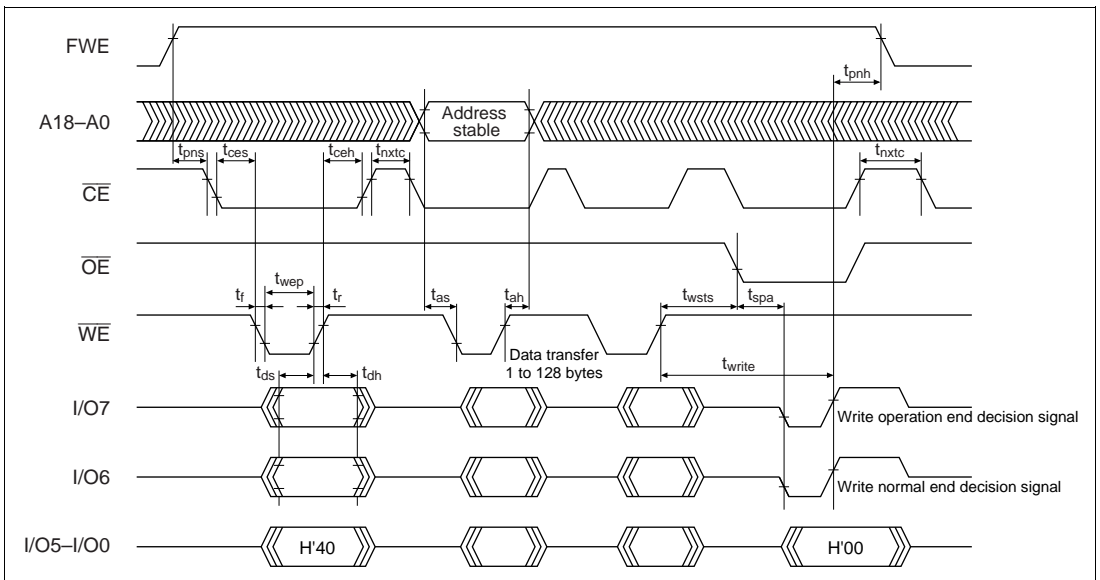
**Figure 17.24**  $\overline{CE}$  and  $\overline{OE}$  Clock System Read Timing Waveforms

### 17.13.4 Auto-Program Mode

1. In auto-program mode, 128 bytes are programmed simultaneously. This should be carried out by executing 128 consecutive byte transfers.
2. A 128-byte data transfer is necessary even when programming fewer than 128 bytes. In this case, H'FF data must be written to the extra addresses.
3. The lower 7 bits of the transfer address must be low. If a value other than an effective address is input, processing will switch to a memory write operation but a write error will be flagged.
4. Memory address transfer is performed in the second cycle (figure 17.25). Do not perform transfer after the third cycle.
5. Do not perform a command write during a programming operation.
6. Perform one auto-program operation for a 128-byte block for each address. Two or more additional programming operations cannot be performed on a previously programmed address block.
7. Confirm normal end of auto-programming by checking I/O6. Alternatively, status read mode can also be used for this purpose (I/O7 status polling uses the auto-program operation end decision pin).
8. Status polling I/O6 and I/O7 pin information is retained until the next command write. As long as the next command write has not been performed, reading is possible by enabling  $\overline{CE}$  and  $\overline{OE}$ .

**Table 17.18 AC Characteristics in Auto-Program Mode (Conditions:  $V_{CC} = 3.3\text{ V} \pm 0.3\text{ V}$ ,  $V_{SS} = 0\text{ V}$ ,  $T_a = 25^\circ\text{C} \pm 5^\circ\text{C}$ )**

Item	Symbol	Min	Max	Unit
Command write cycle	$t_{nxtc}$	20	—	$\mu\text{s}$
$\overline{\text{CE}}$ hold time	$t_{ceh}$	0	—	ns
$\overline{\text{CE}}$ setup time	$t_{ces}$	0	—	ns
Data hold time	$t_{dh}$	50	—	ns
Data setup time	$t_{ds}$	50	—	ns
Write pulse width	$t_{wep}$	70	—	ns
Status polling start time	$t_{wsts}$	1	—	ms
Status polling access time	$t_{spa}$	—	150	ns
Address setup time	$t_{as}$	0	—	ns
Address hold time	$t_{ah}$	60	—	ns
Memory write time	$t_{write}$	1	3000	ms
Write setup time	$t_{pns}$	100	—	ns
Write end setup time	$t_{pnh}$	100	—	ns
$\overline{\text{WE}}$ rise time	$t_r$	—	30	ns
$\overline{\text{WE}}$ fall time	$t_f$	—	30	ns



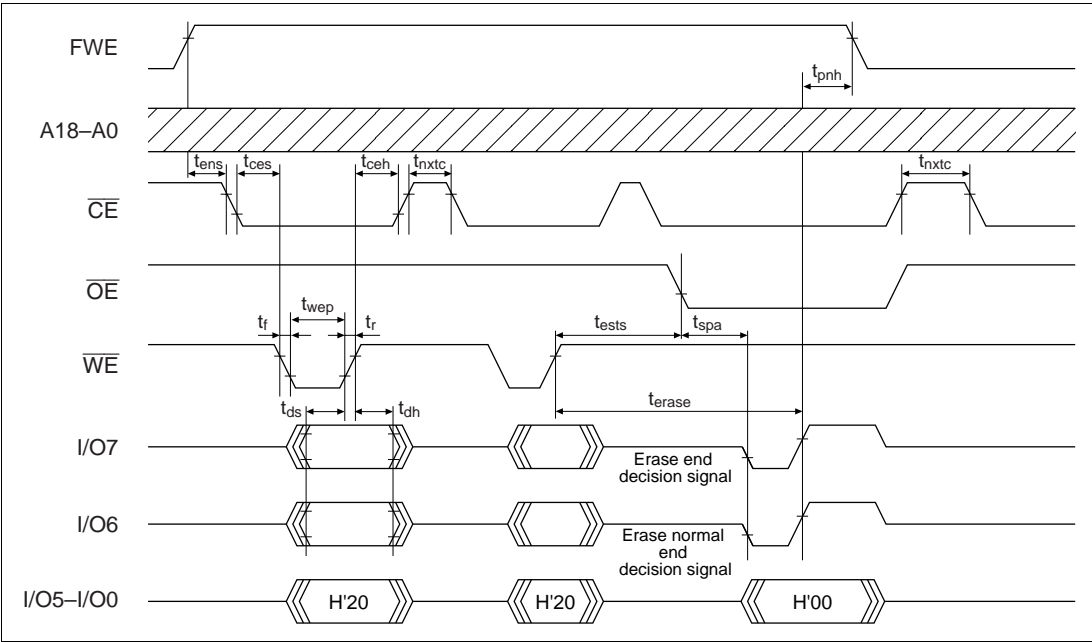
**Figure 17.25 Auto-Program Mode Timing Waveforms**

### 17.13.5 Auto-Erase Mode

1. Auto-erase mode supports only entire memory erasing.
2. Do not perform a command write during auto-erasing.
3. Confirm normal end of auto-erasing by checking I/O6. Alternatively, status read mode can also be used for this purpose (I/O7 status polling uses the auto-erase operation end decision pin).
4. Status polling I/O6 and I/O7 pin information is retained until the next command write. As long as the next command write has not been performed, reading is possible by enabling  $\overline{\text{CE}}$  and  $\overline{\text{OE}}$ .

**Table 17.19 AC Characteristics in Auto-Erase Mode (Conditions:  $V_{CC} = 3.3 \text{ V} \pm 3.0 \text{ V}$ ,  $V_{SS} = 0 \text{ V}$ ,  $T_a = 25^\circ\text{C} \pm 5^\circ\text{C}$ )**

Item	Symbol	Min	Max	Unit
Command write cycle	$t_{\text{nxtc}}$	20	—	$\mu\text{s}$
$\overline{\text{CE}}$ hold time	$t_{\text{ceh}}$	0	—	ns
$\overline{\text{CE}}$ setup time	$t_{\text{ces}}$	0	—	ns
Data hold time	$t_{\text{dh}}$	50	—	ns
Data setup time	$t_{\text{ds}}$	50	—	ns
Write pulse width	$t_{\text{wep}}$	70	—	ns
Status polling start time	$t_{\text{ests}}$	1	—	ms
Status polling access time	$t_{\text{spa}}$	—	150	ns
Memory erase time	$t_{\text{erase}}$	100	40000	ms
Erase setup time	$t_{\text{ens}}$	100	—	ns
Erase end setup time	$t_{\text{enh}}$	100	—	ns
$\overline{\text{WE}}$ rise time	$t_r$	—	30	ns
$\overline{\text{WE}}$ fall time	$t_f$	—	30	ns



**Figure 17.26 Auto-Erase Mode Timing Waveforms**

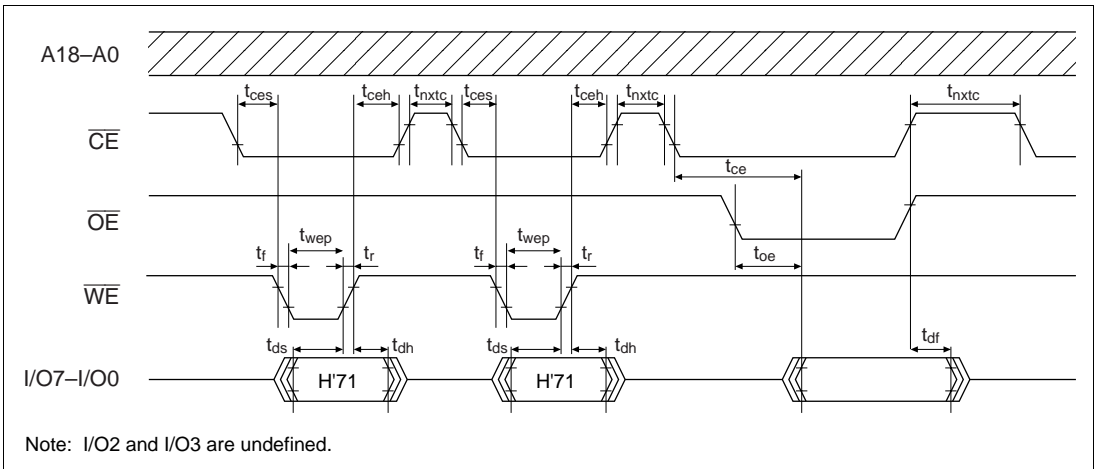


### 17.13.6 Status Read Mode

1. Status read mode is provided to identify the kind of abnormal end. Use this mode when an abnormal end occurs in auto-program mode or auto-erase mode.
2. The return code is retained until a command write other than a status read mode command write is executed.

**Table 17.20 AC Characteristics in Status Read Mode (Conditions:  $V_{CC} = 3.3\text{ V} \pm 0.3\text{ V}$ ,  $V_{SS} = 0\text{ V}$ ,  $T_a = 25^\circ\text{C} \pm 5^\circ\text{C}$ )**

Item	Symbol	Min	Max	Unit
Read time after command write	$t_{nxtc}$	20	—	$\mu\text{s}$
$\overline{\text{CE}}$ hold time	$t_{ceh}$	0	—	ns
$\overline{\text{CE}}$ setup time	$t_{ces}$	0	—	ns
Data hold time	$t_{dh}$	50	—	ns
Data setup time	$t_{ds}$	50	—	ns
Write pulse width	$t_{wep}$	70	—	ns
$\overline{\text{OE}}$ output delay time	$t_{oe}$	—	150	ns
Disable delay time	$t_{df}$	—	100	ns
$\overline{\text{CE}}$ output delay time	$t_{ce}$	—	150	ns
$\overline{\text{WE}}$ rise time	$t_r$	—	30	ns
$\overline{\text{WE}}$ fall time	$t_f$	—	30	ns



**Figure 17.27 Status Read Mode Timing Waveforms**

**Table 17.21 Status Read Mode Return Commands**

Pin Name	I/O7	I/O6	I/O5	I/O4	I/O3	I/O2	I/O1	I/O0
Attribute	Normal end decision	Command error	Programming error	Erase error	—	—	Programming or erase count exceeded	Effective address error
Initial value	0	0	0	0	0	0	0	0
Indications	Normal end: 0 Abnormal end: 1	Command error: 1 Otherwise: 0	Programming error: 1 Otherwise: 0	Erasing error: 1 Otherwise: 0	—	—	Count exceeded: 1 Otherwise: 0	Effective address error: 1 Otherwise: 0

Note: I/O2 and I/O3 are undefined.

### 17.13.7 Status Polling

1. The I/O7 status polling flag indicates the operating status in auto-program/auto-erase mode.
2. The I/O6 status polling flag indicates a normal or abnormal end in auto-program/auto-erase mode.

**Table 17.22 Status Polling Output Truth Table**

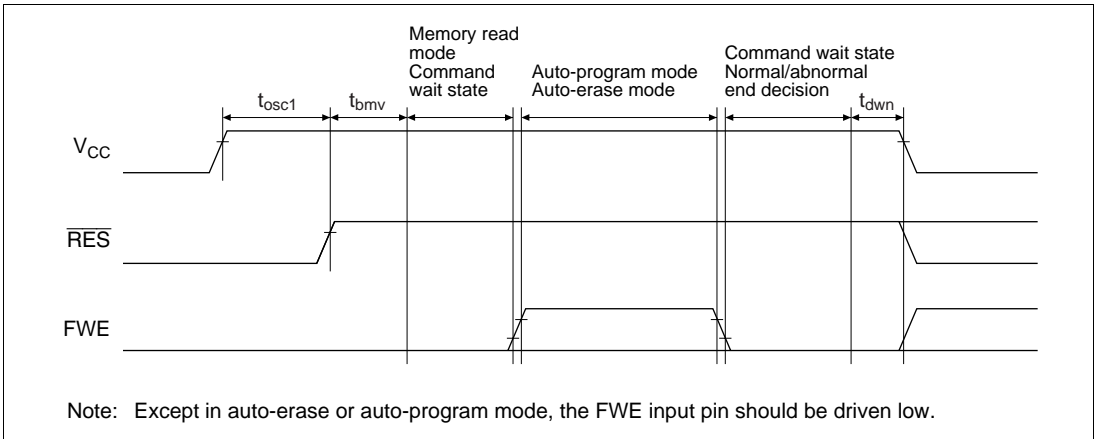
Pin Name	During Internal Operation	Abnormal End	—	Normal End
I/O7	0	1	0	1
I/O6	0	0	1	1
I/O0–I/O5	0	0	0	0

### 17.13.8 Programmer Mode Transition Time

Commands cannot be accepted during the oscillation stabilization period or the programmer mode setup period. After the programmer mode setup time, a transition is made to memory read mode.

**Table 17.23 Stipulated Transition Times to Command Wait State**

Item	Symbol	Min	Max	Unit
Standby release (oscillation stabilization time)	$t_{osc1}$	30	—	ms
Programmer mode setup time	$t_{bmv}$	10	—	ms
$V_{CC}$ hold time	$t_{dwn}$	0	—	ms



**Figure 17.28 Oscillation Stabilization Time, Boot Program Transfer Time, and Power-Down Sequence**

### 17.13.9 Notes on Memory Programming

1. When programming addresses which have previously been programmed, carry out auto-erasing before auto-programming.
2. When performing programming using programmer mode on a chip that has been programmed/erased in an on-board programming mode, auto-erasing is recommended before carrying out auto-programming.

- Notes:
1. The flash memory is initially in the erased state when the device is shipped by Hitachi. For other chips for which the erasure history is unknown, it is recommended that auto-erasing be executed to check and supplement the initialization (erase) level.
  2. Auto-programming should be performed once only on the same address block. Additional programming cannot be performed on previously programmed address blocks.

## 17.14 Flash Memory and Power-Down States

In addition to its normal operating state, the flash memory has power-down states in which power consumption is reduced by halting part or all of the internal power supply circuitry.

There are three flash memory operating states:

- (1) Normal operating mode: The flash memory can be read and written to.
- (2) Power-down mode: Part of the power supply circuitry is halted, and the flash memory can be read only when the LSI is operating on the subclock.
- (3) Standby mode: All flash memory circuits are halted, and the flash memory cannot be read or written to.

States (2) and (3) are flash memory power-down states. Table 17.24 shows the correspondence between the operating states of the LSI and the flash memory.

**Table 17.24 Flash Memory Operating States**

<b>LSI Operating State</b>	<b>Flash Memory Operating State</b>
High-speed mode	Normal mode (read/write)
Medium-speed mode	
Sleep mode	
Subactive mode	When PDWND = 0: Power-down mode (read-only)
Subsleep mode	When PDWND = 1: Normal mode (read-only)
Watch mode	Standby mode
Software standby mode	
Hardware standby mode	

Note: PDWND is valid only when the LSI is in subactive mode or subsleep mode, and is invalid in other modes.

### 17.14.1 Note on Power-Down States

When the flash memory is in a power-down state, part or all of the internal power supply circuitry is halted. Therefore, a power supply circuit stabilization period must be provided when returning to normal operation. When the flash memory returns to its normal operating state from a power-down state, bits STS2 to STS0 in SBYCR must be set to provide a wait time of at least 100  $\mu$ s (power supply stabilization time), even if an oscillation stabilization period is not necessary.

## 17.15 Flash Memory Programming and Erasing Precautions

Precautions concerning the use of on-board programming mode, the RAM emulation function, and PROM mode are summarized below.

### Use the specified voltages and timing for programming and erasing

Applied voltages in excess of the rating can permanently damage the device. Use a PROM programmer that supports the Hitachi microcomputer device type with 128-kbyte on-chip flash memory (FZTAT128V3A).

Do not select the HN27C101 or the HN28F101 setting for the PROM programmer, and only use the specified socket adapter. Failure to observe these points may result in damage to the device.

### Powering on and off (See figures 17.29 to 17.31)

Do not apply a high level to the FWE pin until  $V_{CC}$  has stabilized. Also, drive the FWE pin low before turning off  $V_{CC}$ .

When applying or disconnecting  $V_{CC}$  power, fix the FWE pin low and place the flash memory in the hardware protection state.

The power-on and power-off timing requirements should also be satisfied in the event of a power failure and subsequent recovery.

### FWE application/disconnection (See figures 17.29 to 17.31)

FWE application should be carried out when MCU operation is in a stable condition. If MCU operation is not stable, fix the FWE pin low and set the protection state.

The following points must be observed concerning FWE application and disconnection to prevent unintentional programming or erasing of flash memory:

- Apply FWE when the  $V_{CC}$  voltage has stabilized within its rated voltage range.
- In boot mode, apply and disconnect FWE during a reset.
- In user program mode, FWE can be switched between high and low level regardless of the reset state. FWE input can also be switched during execution of a program in flash memory.
- Do not apply FWE if program runaway has occurred.
- Disconnect FWE only when the SWE1, ESU1, PSU1, EV1, PV1, P1, and E1 bits in FLMCR1 are cleared.

Make sure that the SWE1, ESU1, PSU1, EV1, PV1, P1, and E1 bits are not set by mistake when applying or disconnecting FWE.

## **Do not apply a constant high level to the FWE pin**

Apply a high level to the FWE pin only when programming or erasing flash memory. A system configuration in which a high level is constantly applied to the FWE pin should be avoided. Also, while a high level is applied to the FWE pin, the watchdog timer should be activated to prevent overprogramming or overerasing due to program runaway, etc.

## **Use the recommended algorithm when programming and erasing flash memory**

The recommended algorithm enables programming and erasing to be carried out without subjecting the device to voltage stress or sacrificing program data reliability. When setting the P1 or E1 bit in FLMCR1, the watchdog timer should be set beforehand as a precaution against program runaway, etc.

## **Do not set or clear the SWE1 bit during execution of a program in flash memory**

Wait for at least 100  $\mu$ s after clearing the SWE1 bit before executing a program or reading data in flash memory. When the SWE1 bit is set, data in flash memory can be rewritten, but access flash memory only for verify operations (verification during programming/erasing). Also, do not clear the SWE1 bit during programming, erasing, or verifying.

Similarly, when using emulation by RAM with a high level applied to the FWE pin, the SWE1 bit should be cleared before executing a program or reading data in flash memory. However, read/write accesses can be performed in the RAM area overlapping the flash memory space regardless of whether the SWE1 bit is set or cleared.

## **Do not use interrupts while flash memory is being programmed or erased**

All interrupt requests, including NMI, should be disabled during FWE application to give priority to program/erase operations.

## **Do not perform additional programming. Erase the memory before reprogramming**

In on-board programming, perform only one programming operation on a 128-byte programming unit block. In programmer mode, too, perform only one programming operation on a 128-byte programming unit block. Programming should be carried out with the entire programming unit block erased.

## **Before programming, check that the chip is correctly mounted in the PROM programmer**

Overcurrent damage to the device can result if the index marks on the PROM programmer socket, socket adapter, and chip are not correctly aligned.

## **Do not touch the socket adapter or chip during programming**

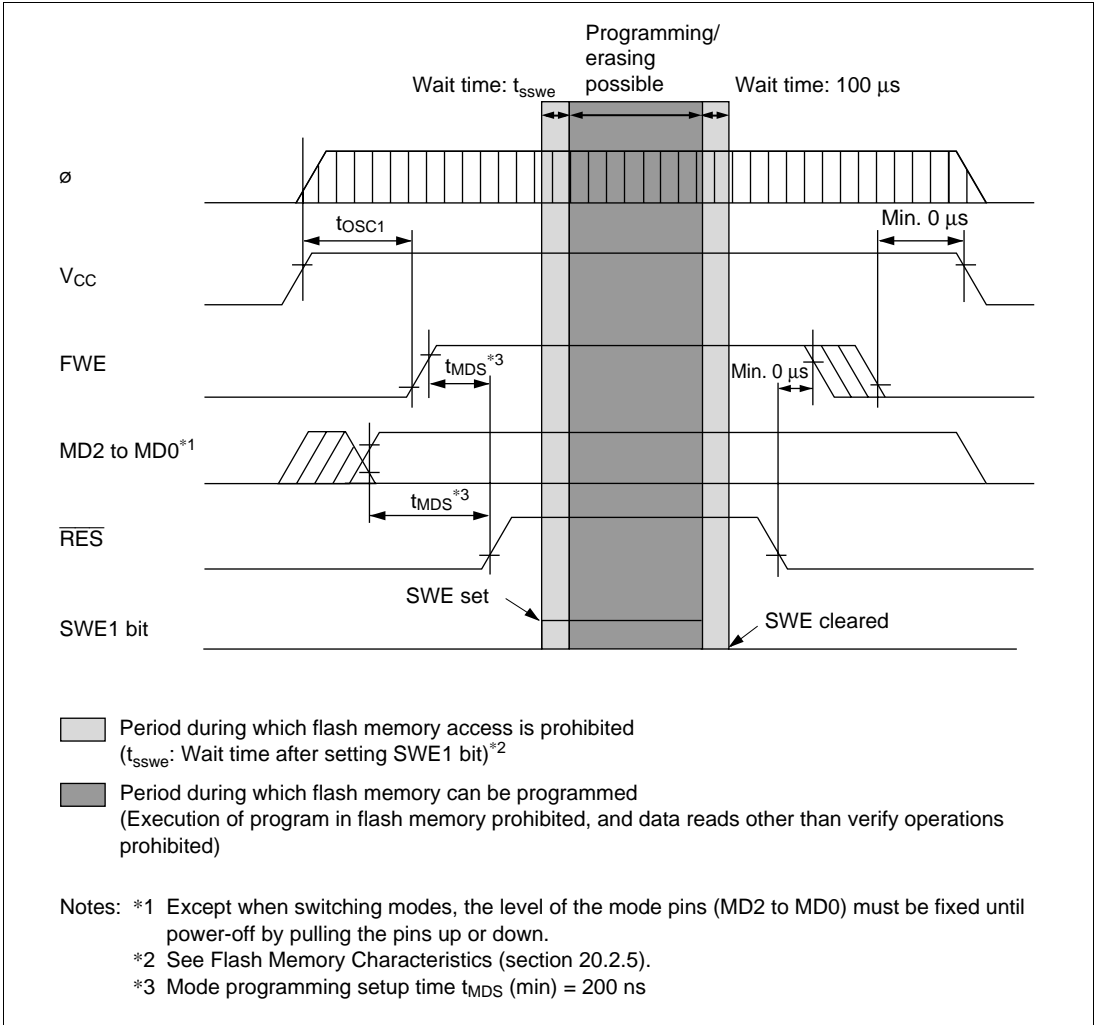
Touching either of these can cause contact faults and write errors.

**The reset state must be entered after powering on**

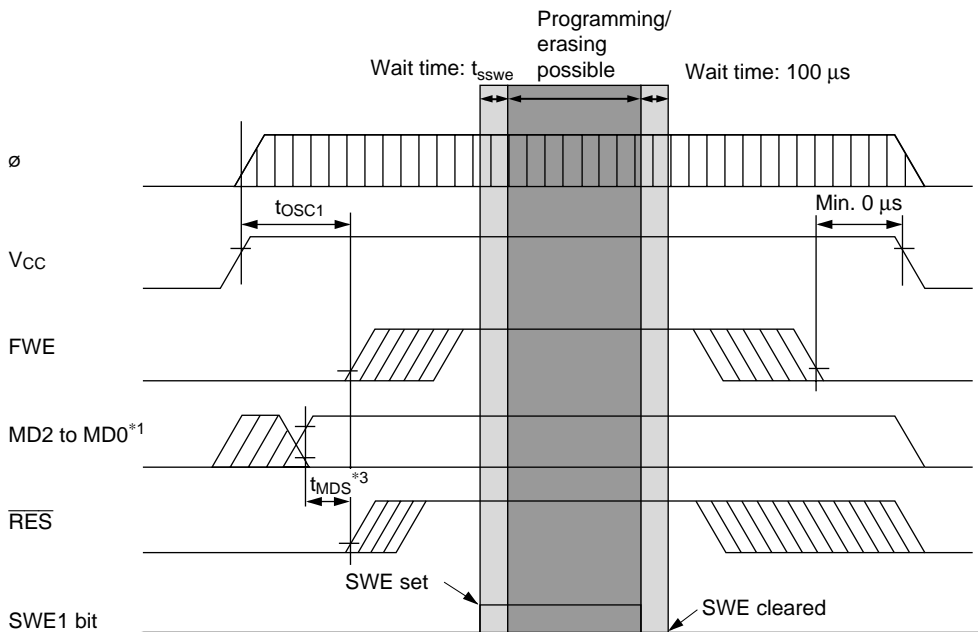
Apply the reset signal for at least 100  $\mu\text{s}$  during the oscillation setting period.

**When a reset is applied during operation, this should be done while the SWE1 pin is low.**

Wait at least 100  $\mu\text{s}$  after clearing the SWE1 bit before applying the reset.



**Figure 17.29 Power-On/Off Timing (Boot Mode)**

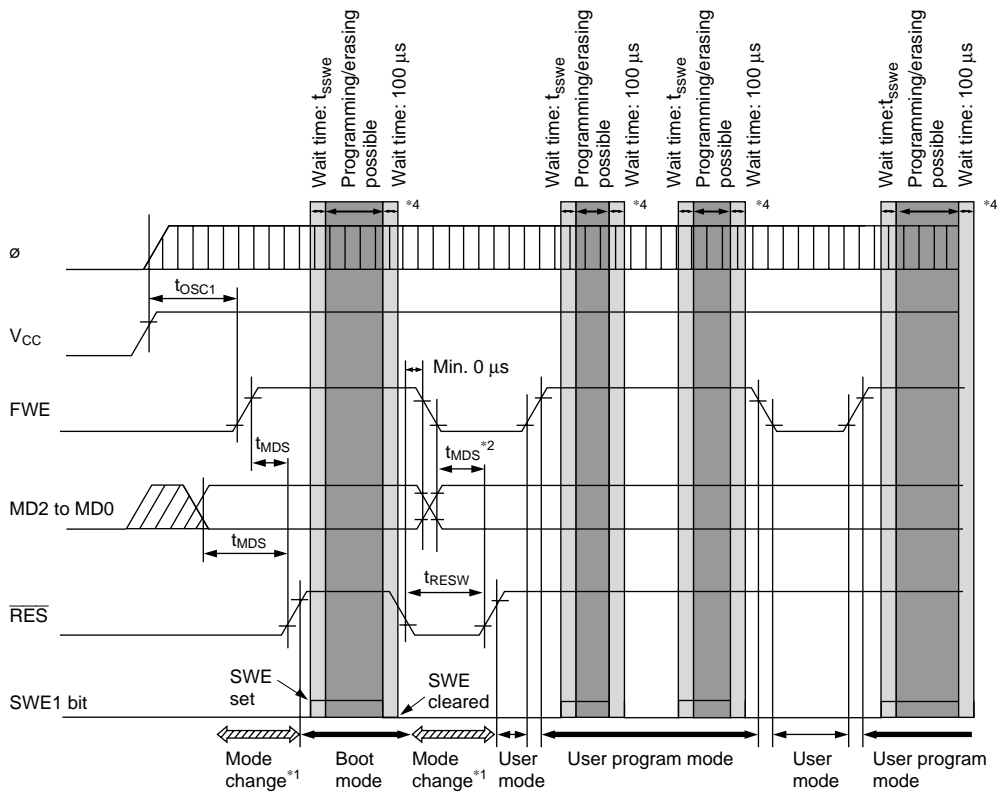


- Period during which flash memory access is prohibited ( $t_{sswe}$ : Wait time after setting SWE1 bit)<sup>\*2</sup>
- Period during which flash memory can be programmed (Execution of program in flash memory prohibited, and data reads other than verify operations prohibited)

Notes: \*1 Except when switching modes, the level of the mode pins (MD2 to MD0) must be fixed until power-off by pulling the pins up or down.  
 \*2 See Flash Memory Characteristics (section 20.2.5).  
 \*3 Mode programming setup time  $t_{MDS}$  (min) = 200 ns

**Figure 17.30 Power-On/Off Timing (User Program Mode)**





- Period during which flash memory access is prohibited ( $t_{sswe}$ : Wait time after setting SWE1 bit)<sup>\*3</sup>
- Period during which flash memory can be programmed (Execution of program in flash memory prohibited, and data reads other than verify operations prohibited)

Notes: <sup>\*1</sup> When entering boot mode or making a transition from boot mode to another mode, mode switching must be carried out by means of RES input. The state of ports with multiplexed address functions and bus control output pins ( $\overline{AS}$ ,  $\overline{RD}$ ,  $\overline{WR}$ ) will change during this switchover interval (the interval during which the RES pin input is low), and therefore these pins should not be used as output signals during this time.

<sup>\*2</sup> When making a transition from boot mode to another mode, a mode programming setup time  $t_{MDS}$  (min) of 200 ns is necessary with respect to RES clearance timing.

<sup>\*3</sup> See Flash Memory Characteristics (section 20.2.5).

<sup>\*4</sup> Wait time: 100  $\mu$ s

**Figure 17.31 Mode Transition Timing**  
**(Example: Boot Mode → User Mode ↔ User Program Mode)**



# Section 18 Clock Pulse Generator

## 18.1 Overview

The LSI has a built-in clock pulse generator (CPG) that generates the system clock ( $\phi$ ), the bus master clock, and internal clocks.

The clock pulse generator consists of a system clock oscillator, duty adjustment circuit, clock selection circuit, medium-speed clock divider, bus master clock selection circuit, subclock oscillator, and waveform shaping circuit.

### 18.1.1 Block Diagram

Figure 18.1 shows a block diagram of the clock pulse generator.

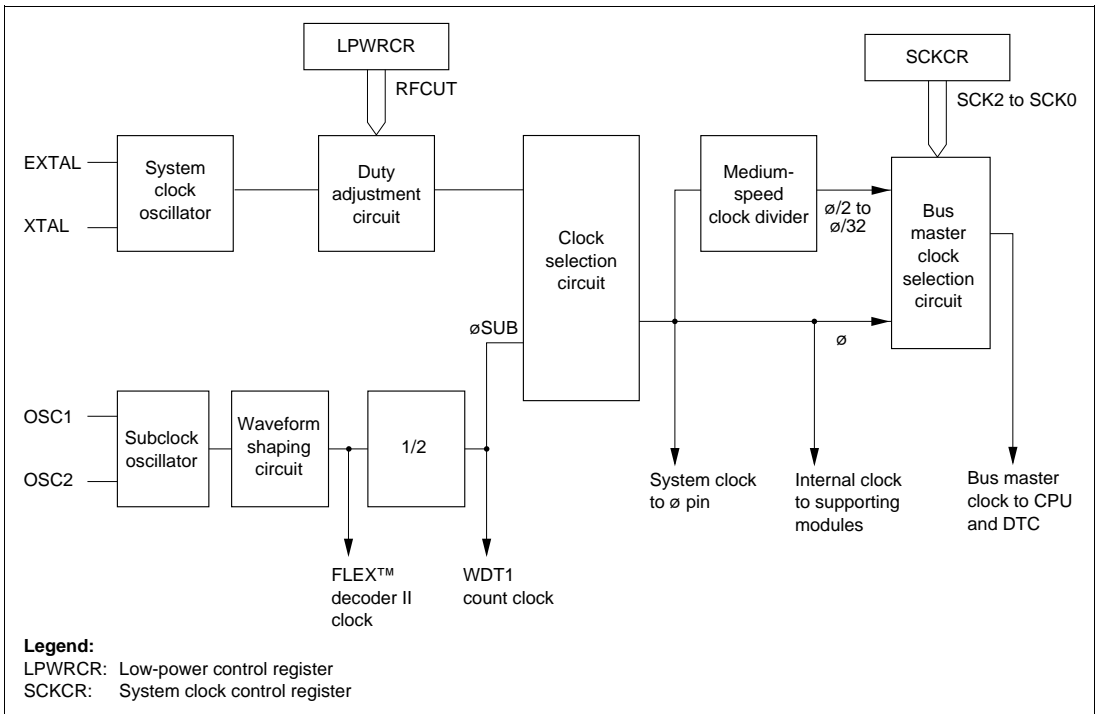


Figure 18.1 Block Diagram of Clock Pulse Generator

## 18.1.2 Register Configuration

The clock pulse generator is controlled by SCKCR and LPWRCR. Table 18.1 shows the register configuration.

**Table 18.1 Clock Pulse Generator Register**

Name	Abbreviation	R/W	Initial Value	Address*
System clock control register	SCKCR	R/W	H'00	H'FDE6
Low-power control register	LPWRCR	R/W	H'00	H'FDEC

Note:\* Lower 16 bits of the address.

## 18.2 Register Descriptions

### 18.2.1 System Clock Control Register (SCKCR)

Bit	:	7	6	5	4	3	2	1	0
		PSTOP	—	—	—	—	SCK2	SCK1	SCK0
Initial value:		0	0	0	0	0	0	0	0
R/W	:	R/W	R/W	R/W	R/W	R/W	R/W	R/W	R/W

SCKCR is an 8-bit readable/writable register that performs  $\emptyset$  clock output control and medium-speed mode control.

SCKCR is initialized to H'00 by a reset and in hardware standby mode. It is not initialized in software standby mode.

**Bit 7— $\emptyset$  Clock Output Disable (PSTOP):** Controls  $\emptyset$  output.

Bit 7	Description			
PSTOP	High-Speed Mode, Medium-Speed Mode, Subactive Mode	Sleep Mode Subsleeeep Mode	Software Standby Mode, Watch Mode, Direct Transition	Hardware Standby Mode
0	$\emptyset$ output (initial value)	$\emptyset$ output	Fixed high	High impedance
1	Fixed high	Fixed high	Fixed high	High impedance

**Bits 6 to 3—Reserved:** Only 0 should be written to these bits.

**Bits 2 to 0—System Clock Select 2 to 0 (SCK2 to SCK0):** These bits select the bus master clock used in high-speed mode and medium-speed mode. In the case of transition to subactive mode or watch mode, bits SCK2 to SCK0 should all be cleared to 0.

Bit 2	Bit 1	Bit 0	Description
SCK2	SCK1	SCK0	
0	0	0	Bus master is in high-speed mode (Initial value)
		1	Medium-speed clock is $\phi/2$
	1	0	Medium-speed clock is $\phi/4$
		1	Medium-speed clock is $\phi/8$
1	0	0	Medium-speed clock is $\phi/16$
		1	Medium-speed clock is $\phi/32$
	1	—	—

### 18.2.2 Low-Power Control Register (LPWRCR)

Bit	:	7	6	5	4	3	2	1	0
		DTON	LSON	NESEL	SUBSTP	RFCUT	—	STC1	STC0
Initial value	:	0	0	0	0	0	0	0	0
R/W	:	R/W	R/W	R/W	R/W	R/W	R/W	R/W	R/W

LPWRCR is an 8-bit readable/writable register that performs power-down mode control.

LPWRCR is initialized to H'00 by a power-on reset and in hardware standby mode. It is not initialized in software standby mode.

**Bit 7—Direct-Transfer On Flag (DTON):** Specifies whether a direct transition is made between high-speed mode or medium-speed mode and subactive mode when making a power-down transition by executing a SLEEP instruction. The operating mode to which the transition is made after SLEEP instruction execution is determined by a combination of other control bits.

## Bit 7

DTON	Description
0	<ul style="list-style-type: none"><li>When a SLEEP instruction is executed in high-speed mode or medium-speed mode, a transition is made to sleep mode, software standby mode, or watch mode</li><li>When a SLEEP instruction is executed in subactive mode, a transition is made to subsleep mode or watch mode (Initial value)</li></ul>
1	<ul style="list-style-type: none"><li>When a SLEEP instruction is executed in high-speed mode or medium-speed mode, a transition is made directly to subactive mode*, or a transition is made to sleep mode or software standby mode</li><li>When a SLEEP instruction is executed in subactive mode, a transition is made directly to high-speed mode, or a transition is made to subsleep mode</li></ul>

Note: \* In the case of a transition to watch mode or subactive mode, high-speed mode must be set.

**Bit 6—Low-Speed On Flag (LSON):** Determines the operating mode in combination with other control bits when making a power-down transition by executing a SLEEP instruction. Also controls whether a transition is made to high-speed mode or medium-speed mode, or to subactive mode, when watch mode is cleared.

## Bit 6

LSON	Description
0	<ul style="list-style-type: none"><li>When a SLEEP instruction is executed in high-speed mode or medium-speed mode, a transition is made to sleep mode, software standby mode, or watch mode</li><li>When a SLEEP instruction is executed in subactive mode, a transition is made to watch mode*, or directly to high-speed mode</li><li>After watch mode is cleared, a transition is made to high-speed mode (Initial value)</li></ul>
1	<ul style="list-style-type: none"><li>When a SLEEP instruction is executed in high-speed mode, a transition is made to watch mode or subactive mode</li><li>When a SLEEP instruction is executed in subactive mode, a transition is made to subsleep mode or watch mode</li><li>After watch mode is cleared, a transition is made to subactive mode</li></ul>

Note: \* In the case of a transition to watch mode or subactive mode, high-speed mode must be set.

**Bit 5—Noise Elimination Sampling Frequency Select (NESEL):** Selects the frequency at which the subclock ( $\phi$ SUB) generated by the subclock oscillator is sampled with the clock ( $\phi$ ) generated by the system clock oscillator. When  $\phi = 5$  MHz or higher, this bit should be cleared to 0.

**Bit 5**

NESEL	Description
0	Sampling at $\phi$ divided by 8 (Initial value)
1	Sampling at $\phi$ divided by 4

**Bit 4—Subclock Oscillator Control (SUBSTP):** Controls operation and stopping of the subclock oscillator.

**Bit 4**

SUBSTP	Description
0	Subclock oscillator operates (Initial value)
1	Subclock oscillator is stopped

Note: When the subclock is not used, this bit should be set to 1.

**Bit 3—Built-in Feedback Resistor Control (RFCUT):** Selects whether the oscillator's built-in feedback resistor and duty adjustment circuit are used with external clock input. Do not access this bit when a crystal oscillator is used.

After this bit is set when using external clock input, a transition should initially be made to software standby mode, watch mode, or subactive mode. Switching between use and non-use of the oscillator's built-in feedback resistor and duty adjustment circuit is performed when the transition is made to software standby mode, watch mode, or subactive mode.

**Bit 3**

RFCUT	Description
0	System clock oscillator's built-in feedback resistor and duty adjustment circuit are used (Initial value)
1	System clock oscillator's built-in feedback resistor and duty adjustment circuit are not used

**Bit 2—Reserved:** This bit can be read or written to, but should only be written with 0.

**Bits 1 and 0—Frequency Multiplication Factor (STC1, STC0):** The STC bits specify the frequency multiplication factor of the PLL circuit incorporated into the evaluation chip. The specified frequency multiplication factor is valid after a transition to software standby mode, watch mode, or subactive mode.

With the LSI, STC1 and STC0 must both be set to 1. After a reset, STC1 and STC0 are both cleared to 0, and so must be set to 1.

<b>Bit 1</b>	<b>Bit 0</b>	<b>Description</b>
<b>STC1</b>	<b>STC0</b>	
0	0	x1 (Initial value)
	1	x2 (Setting prohibited)
1	0	x4 (Setting prohibited)
	1	PLL is bypassed



## 18.3 System Clock Oscillator

Clock pulses can be supplied by connecting a crystal resonator, or by input of an external clock.

### 18.3.1 Connecting a Crystal Resonator

**Circuit Configuration:** A crystal resonator can be connected as shown in the example in figure 18.2. Select the damping resistance  $R_d$  according to table 18.2. An AT-cut parallel-resonance crystal should be used.

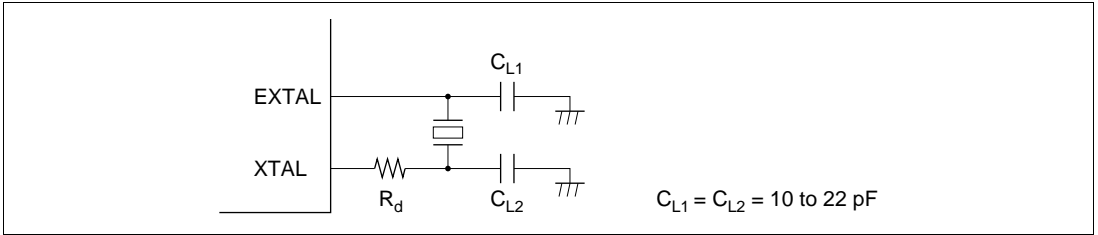


Figure 18.2 Connection of Crystal Resonator (Example)

Table 18.2 Damping Resistance Value

Frequency (MHz)	2	4	6	8	10	12
$R_d$ ( $\Omega$ )	1 k	500	300	200	100	0

**Crystal Resonator:** Figure 18.3 shows the equivalent circuit of the crystal resonator. Use a crystal resonator that has the characteristics shown in table 18.3 and the same resonance frequency as the system clock ( $\phi$ ).

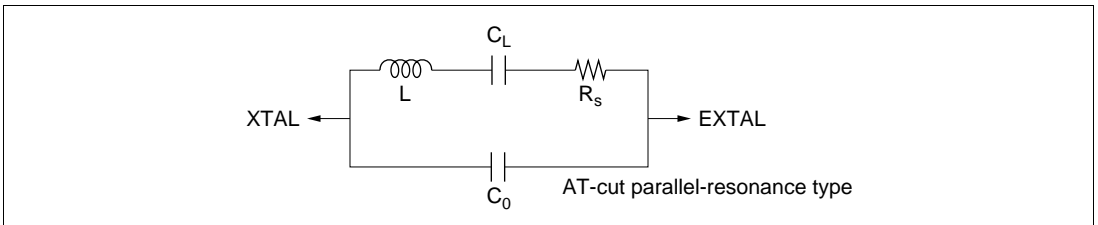


Figure 18.3 Crystal Resonator Equivalent Circuit

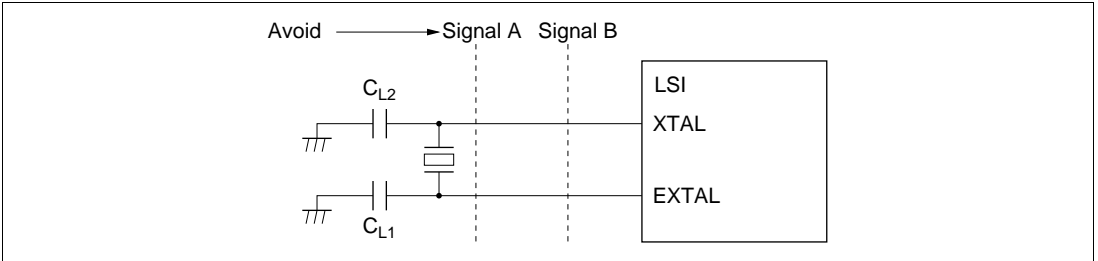
Table 18.3 Crystal Resonator Parameters

Frequency (MHz)	2	4	6	8	10	12
$R_s$ max ( $\Omega$ )	500	120	100	80	60	60
$C_0$ max (pF)	7	7	7	7	7	7

**Note on Board Design:** When a crystal resonator is connected, the following points should be noted:

Other signal lines should be routed away from the oscillator circuit to prevent induction from interfering with correct oscillation. See figure 18.4.

When designing the board, place the crystal resonator and its load capacitors as close as possible to the XTAL and EXTAL pins.

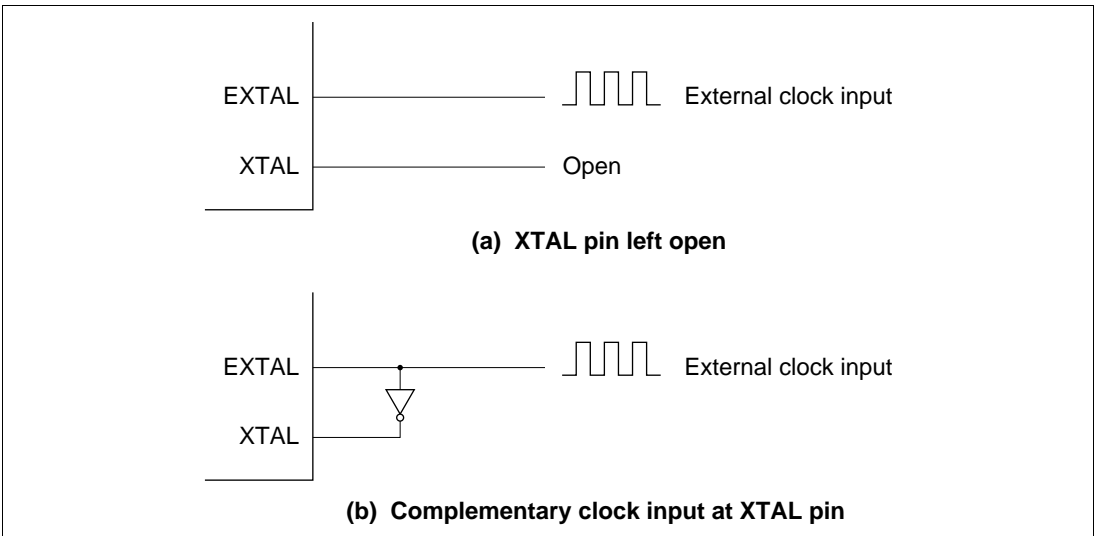


**Figure 18.4 Example of Incorrect Board Design**

### 18.3.2 External Clock Input

**Circuit Configuration:** An external clock signal can be input as shown in the examples in figure 18.5. If the XTAL pin is left open, make sure that stray capacitance is no more than 10 pF.

In example (b), make sure that the external clock is held high in standby mode, subactive mode, subsleep mode, and watch mode.



**Figure 18.5 External Clock Input (Examples)**

**External Clock:** The external clock signal should have the same frequency as the system clock ( $\phi$ ).

Table 18.4 and figure 18.6 show the input conditions for the external clock.

**Table 18.4 External Clock Input Conditions**

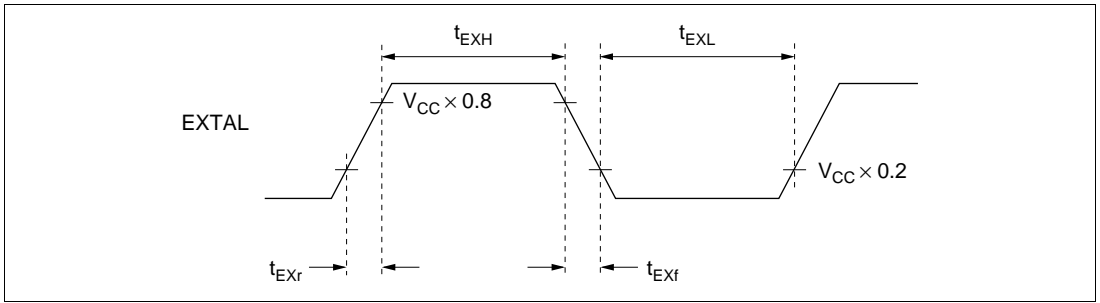
Item	Symbol	F-ZTAT Version			Unit	Conditions
		$V_{CC} = 2.7\text{ V to }3.6\text{ V}$				
		Min	Max			
External clock input low pulse width	$t_{EXL}$	30	—	ns		Figure 18.6
External clock input high pulse width	$t_{EXH}$	30	—	ns		
External clock rise time	$t_{EXr}$	—	7	ns		
External clock fall time	$t_{EXf}$	—	7	ns		
Clock low pulse width level	$t_{CL}$	0.4	0.6	$t_{cyc}$	$\phi \geq 5\text{ MHz}$	Figure 20.3
		80	—	ns	$\phi < 5\text{ MHz}$	
Clock high pulse width level	$t_{CH}$	0.4	0.6	$t_{cyc}$	$\phi \geq 5\text{ MHz}$	
		80	—	ns	$\phi < 5\text{ MHz}$	

The external clock input conditions when the duty adjustment circuit is not used are shown in table 18.5 and figure 18.6. When the duty adjustment circuit is not used, the  $\phi$  output waveform depends on the external clock input waveform, and so no restrictions apply.

**Table 18.5 External Clock Input Conditions when the Duty Adjustment Circuit is not Used**

Item	Symbol	F-ZTAT Version			Unit	Conditions
		$V_{CC} = 2.7\text{ V to }3.6\text{ V}$				
		Min	Max			
External clock input low pulse width	$t_{EXL}$	37	—	ns		Figure 18.6
External clock input high pulse width	$t_{EXH}$	37	—	ns		
External clock rise time	$t_{EXr}$	—	7	ns		
External clock fall time	$t_{EXf}$	—	7	ns		

Note: When duty adjustment circuit is not used, the maximum frequency decreases according to the input waveform. (Example: When  $t_{EXL} = t_{EXH} = 50\text{ ns}$ , and  $t_{EXr} = t_{EXf} = 10\text{ ns}$ , clock cycle time = 120 ns; therefore, maximum operating frequency = 8.3 MHz)

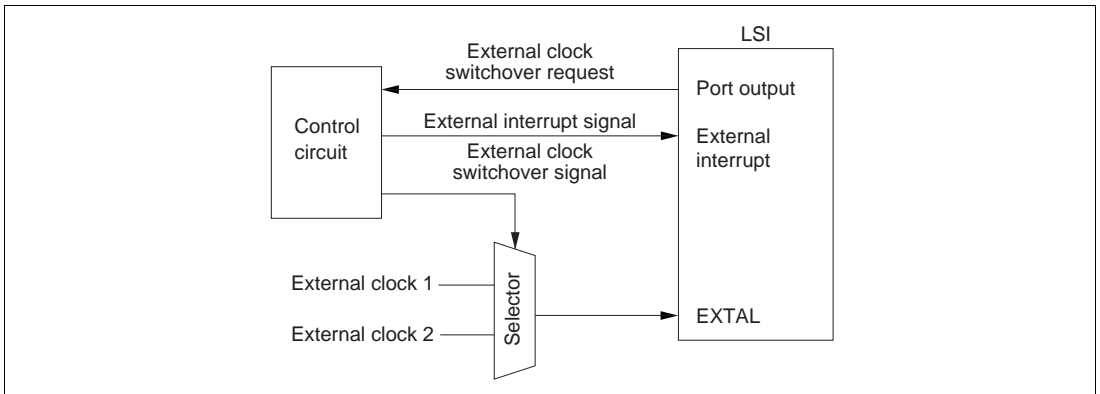


**Figure 18.6 External Clock Input Timing**

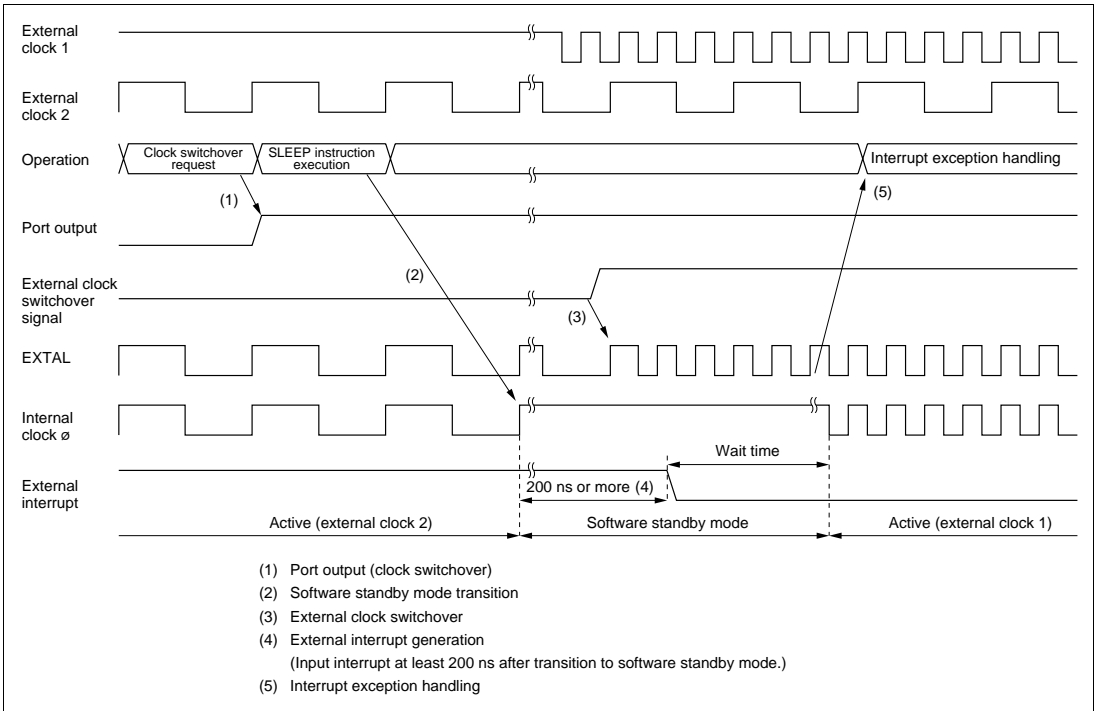
**(3) Note on Switchover of External Clock**

When two or more external clocks (e.g. 10 MHz and 2 MHz) are used as the system clock, switchover of the input clock should be carried out in software standby mode.

An example of an external clock switching circuit is shown in figure 18.7, and an example of the external clock switchover timing in figure 18.8.



**Figure 18.7 Example of External Clock Switching Circuit**



**Figure 18.8 Example of External Clock Switchover Timing**

## 18.4 Duty Adjustment Circuit

When the oscillator frequency is 5 MHz or higher, the duty adjustment circuit adjusts the duty cycle of the clock signal from the oscillator to generate the system clock ( $\phi$ ).

## 18.5 Medium-Speed Clock Divider

The medium-speed clock divider divides the system clock to generate  $\phi/2$ ,  $\phi/4$ ,  $\phi/8$ ,  $\phi/16$ , and  $\phi/32$ .

## 18.6 Bus Master Clock Selection Circuit

The bus master clock selection circuit selects the system clock ( $\phi$ ) or one of the medium-speed clocks ( $\phi/2$ ,  $\phi/4$ , or  $\phi/8$ ,  $\phi/16$ , and  $\phi/32$ ) to be supplied to the bus master, according to the settings of the SCK2 to SCK0 bits in SCKCR.

## 18.7 Subclock Oscillator

### (1) Method of Connecting 76.8 kHz/160 kHz Crystal Resonator

To supply a clock to the subclock oscillator, a 76.8 kHz/160 kHz crystal resonator should be connected as shown in figure 18.9. Cautions concerning the connection are as noted in section 18.3 (3), Notes on Board Design.

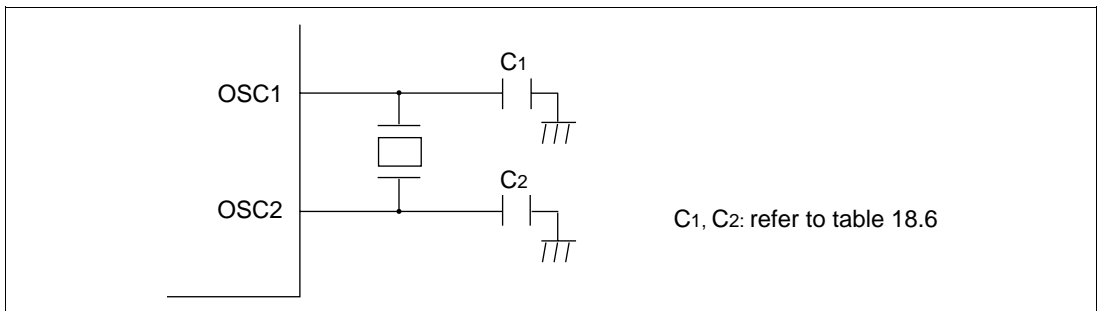
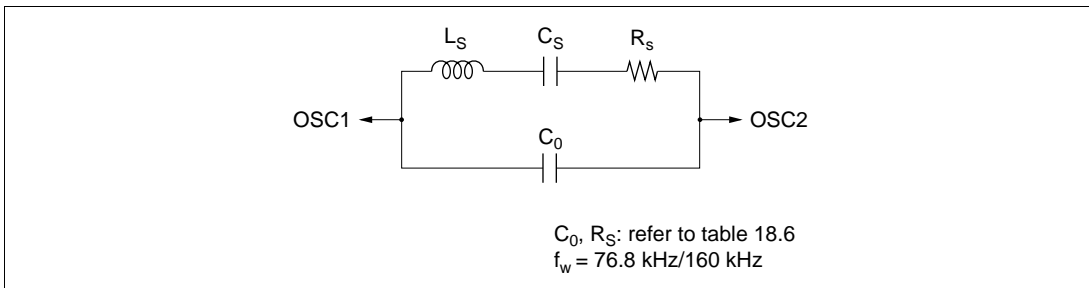


Figure 18.9 Example of Connection of 76.8 kHz/160 kHz Crystal Resonator

Figure 18.10 shows an equivalent circuit for the 76.8 kHz/160 kHz crystal resonator.



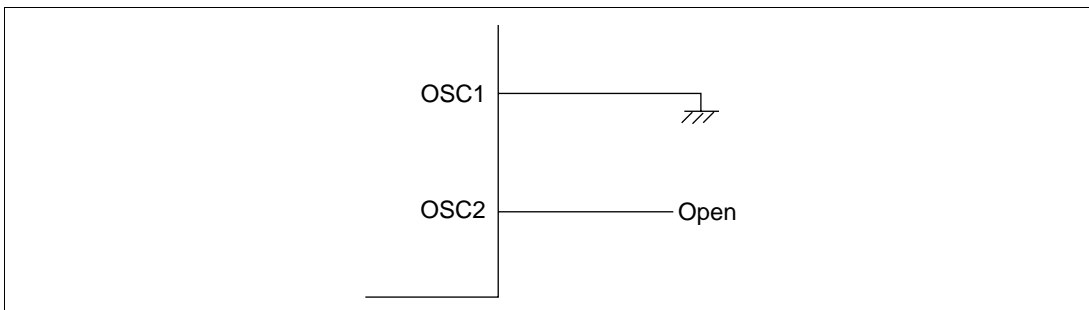
**Figure 18.10 76.8 kHz/160 kHz Crystal Resonator Equivalent Circuit**

**Table 18.6 Reference of Subclock Oscillator**

Oscillation Frequency [kHz]	Type Code	Manufacturer	Load Capacitance C1, C2 [pF]	Equivalent Circuit	
				Shunt Capacitance [pF]	Series Resistance [kΩ]
76.8	T26-76.8	MEC	11	0.8	12
160.0	TF26-160	ILSI	11	1.0	20

## (2) Pin Handling When Subclock Is Not Needed

When the subclock is not needed, connect the OSC1 pin to GND ( $V_{SS}$ ) and leave the OSC2 pin open as shown in figure 18.11, and the SUBSTP bit of LPWRCR should be set to 1.



**Figure 18.11 Pin Handling When Subclock Is Not Needed**

## 18.8 Subclock Waveform Shaping Circuit

To eliminate noise in the subclock input from the OSC1 pin, the signal is sampled using a clock scaled from the  $\phi$  clock. The sampling frequency is set with the NESEL bit in LPWRCCR. For details, see section 18.2.2, Low-Power Control Register (LPWRCCR).

Sampling is not performed in subactive mode, subsleep mode, or watch mode.

## 18.9 Note on Crystal Resonator

Since various characteristics related to the crystal resonator are closely linked to the user's board design, thorough evaluation is necessary on the user's part, using the resonator connection examples shown in this section as a guide. As the resonator circuit ratings will depend on the floating capacitance of the resonator and the mounting circuit, the ratings should be determined in consultation with the resonator manufacturer. The design must ensure that a voltage exceeding the maximum rating is not applied to the oscillator pin.



# Section 19 Power-Down Modes

## 19.1 Overview

In addition to the normal program execution state, the LSI has power-down modes in which operation of the CPU and oscillator is halted and power dissipation is reduced. Low-power operation can be achieved by individually controlling the CPU, on-chip supporting modules, and so on.

The LSI operating modes are as follows:

- (1) High-speed mode
- (2) Medium-speed mode
- (3) Subactive mode
- (4) Sleep mode
- (5) Subsleep mode
- (6) Watch mode
- (7) Module stop mode
- (8) Software standby mode
- (9) Hardware standby mode

Of these, (2) to (9) are power-down modes. Sleep mode and subsleep mode are CPU modes, medium-speed mode is a CPU and bus master mode, subactive mode is a CPU, bus master, and on-chip supporting module mode, and module stop mode is an on-chip supporting module mode (including bus masters other than the CPU). Certain combinations of these modes can be set.


After a reset, the MCU is in high-speed mode.

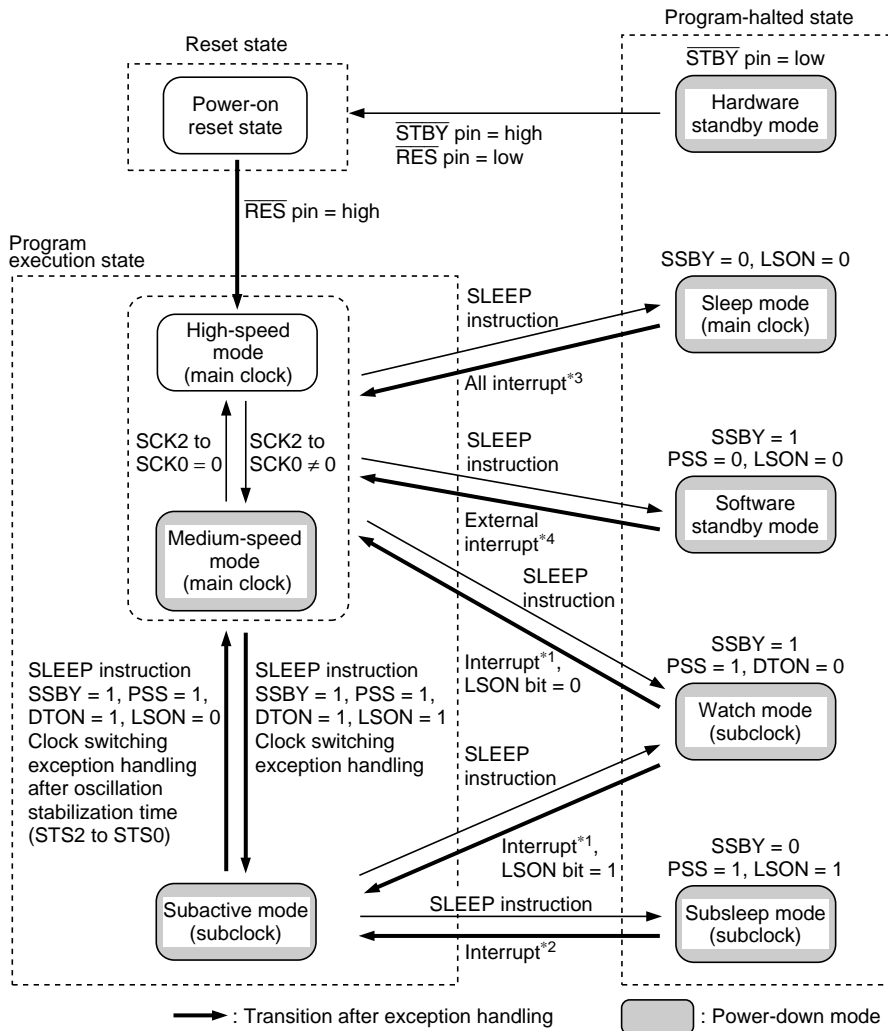
Table 19.1 shows the internal chip states in each mode, and table 19.2 shows the conditions for transition to the various modes. Figure 19.1 shows a mode transition diagram.

**Table 19.1 H8S/2276 Series Internal States in Each Mode**

Function		High-Speed	Medium-Speed	Sleep	Module Stop	Watch	Subactive	Subsleep	Software Standby	Hardware Standby
System clock oscillator		Functioning	Functioning	Functioning	Functioning	Halted	Halted	Halted	Halted	Halted
Subclock oscillator		Functioning/Halted	Functioning/Halted	Functioning/Halted	Functioning/Halted	Functioning	Functioning	Functioning	Functioning/Halted	Halted
CPU operation	Instructions	Functioning	Medium-speed	Halted	Functioning	Halted	Subclock operation	Halted	Halted	Halted
	Registers			Retained		Retained		Retained	Retained	Undefined
RAM		Functioning	Functioning	Functioning (DTC)	Functioning	Retained	Functioning	Retained	Retained	Retained
I/O		Functioning	Functioning	Functioning	Functioning	Retained	Functioning	Retained	Retained	High impedance
External interrupts		Functioning	Functioning	Functioning	Functioning	Functioning	Functioning	Functioning	Functioning	Halted
On-chip supporting module operation	PBC	Functioning	Medium-speed	Functioning	Functioning/halted (retained)	Halted (retained)	Subclock operation	Halted (retained)	Halted (retained)	Halted (reset)
	DTC						Halted (retained)			
	WDT1		Functioning		Functioning	Subclock operation	Subclock operation	Subclock operation		
	WDT0					Halted (retained)				
	TMR				Functioning/halted (retained)					
	TPU						Halted (retained)	Halted (retained)		
	SCI									
	A/D				Functioning/halted (reset)	Halted (reset)	Halted (reset)	Halted (reset)	Halted (reset)	

Note: "Halted (retained)" means that internal register values are retained. The internal state is operation suspended.  
 "Halted (reset)" means that internal register values and internal states are initialized.  
 In module stop mode, only modules for which a stop setting has been made are halted (reset or retained).  
 Subclock oscillation is halted when the SUBSTP bit is set to 1 and a stop setting is made.

: Operating state



- Notes:
- \*1 NMI, IRQ0 to IRQ7, and WDT1 interrupts
  - \*2 NMI, IRQ0 to IRQ7, WDT0 interrupts, WDT1 interrupt, TMR0 and TMR1 interrupt
  - \*3 All interrupts
  - \*4 NMI, IRQ0 to IRQ7

- When a transition is made between modes by means of an interrupt, transition cannot be made on interrupt source generation alone. Ensure that interrupt handling is performed after accepting the interrupt request.
- From any state except hardware standby mode, a transition to the power-on reset state occurs whenever RES goes low.
- From any state, a transition to hardware standby mode occurs when  $\overline{\text{STBY}}$  goes low.
- When a transition is made to watch mode or subactive mode, high-speed mode must be set.

Figure 19.1 Mode Transitions

**Table 19.2 Power-Down Mode Transition Conditions**

State before Transition	Control Bit States at Time of Transition				State after Transition by SLEEP Instruction	State after Return by Interrupt
	SSBY	PSS	LSON	DTON		
High-speed/ medium-speed	0	*	0	*	Sleep	High-speed/ medium-speed
	0	*	1	*	—	—
	1	0	0	*	Software standby	High-speed/ medium-speed
	1	0	1	*	—	—
	1	1	0	0	Watch	High-speed
	1	1	1	0	Watch	Subactive
	1	1	0	1	—	—
	1	1	1	1	Subactive	—
Subactive	0	0	*	*	—	—
	0	1	0	*	—	—
	0	1	1	*	Subsleep	Subactive
	1	0	*	*	—	—
	1	1	0	0	Watch	High-speed
	1	1	1	0	Watch	Subactive
	1	1	0	1	High-speed	—
	1	1	1	1	—	—

\*: Don't care

—: Don't set.

## 19.1.1 Register Configuration

The power-down modes are controlled by the SBYCR, SCKCR, LPWRCR, TCSR (WDT1), and MSTPCR registers. Table 19.3 summarizes these registers.

**Table 19.3 Power-Down Mode Registers**

Name	Abbreviation	R/W	Initial Value	Address*
Standby control register	SBYCR	R/W	H'08	H'FDE4
System clock control register	SCKCR	R/W	H'00	H'FDE6
Low-power control register	LPWRCR	R/W	H'00	H'FDEC
Timer control/status register (WDT1)	TCSR	R/W	H'00	H'FFA2
Module stop control register	MSTPCRA	R/W	H'3F	H'FDE8
	MSTPCRB	R/W	H'FF	H'FDE9
	MSTPCRC	R/W	H'FF	H'FDEA

Note: \* Lower 16 bits of the address.

## 19.2 Register Descriptions

### 19.2.1 Standby Control Register (SBYCR)

Bit	:	7	6	5	4	3	2	1	0
		SSBY	STS2	STS1	STS0	OPE	—	—	—
Initial value	:	0	0	0	0	1	0	0	0
R/W	:	R/W	R/W	R/W	R/W	R/W	—	—	—

SBYCR is an 8-bit readable/writable register that performs power-down mode control.

SBYCR is initialized to H'08 by a reset and in hardware standby mode. It is not initialized in software standby mode.

**Bit 7—Software Standby (SSBY):** Determines the operating mode, in combination with other control bits, when a power-down mode transition is made by executing a SLEEP instruction. The SSBY setting is not changed by a mode transition due to an interrupt, etc.

**Bit 7**

SSBY	Description
0	Transition to sleep mode after execution of SLEEP instruction in high-speed mode or medium-speed mode (Initial value) Transition to subsleep mode after execution of SLEEP instruction in subactive mode
1	Transition to software standby mode, subactive mode, or watch mode after execution of SLEEP instruction in high-speed mode or medium-speed mode Transition to watch mode or high-speed mode after execution of SLEEP instruction in subactive mode

**Bits 6 to 4—Standby Timer Select 2 to 0 (STS2 to STS0):** These bits select the time the MCU waits for the clock to stabilize when software standby mode, watch mode, or subactive mode is cleared and a transition is made to high-speed mode or medium-speed mode by means of a specific interrupt or instruction. With crystal oscillation, refer to table 19.5 and make a selection according to the operating frequency so that the standby time is at least 8 ms (the oscillation stabilization time). With an external clock, any selection\* can be made.

Note: \* In the F-ZTAT version, a 16-state wait time cannot be used with an external clock. Use 8192 states or more.

Bit 6	Bit 5	Bit 4	Description
STS2	STS1	STS0	
0	0	0	Standby time = 8192 states (Initial value)
		1	Standby time = 16384 states
	1	0	Standby time = 32768 states
		1	Standby time = 65536 states
1	0	0	Standby time = 131072 states
		1	Standby time = 262144 states
	1	0	Reserved
		1	Standby time = 16 states*

Note: \* Not used on the F-ZTAT version.

**Bit 2 to 0—Reserved:** These bits cannot be modified and is always read as 0.

**Bit 3—Output Port Enable (OPE):** Specifies whether the address bus and bus control signals ( $\overline{CS0}$  to  $\overline{CS3}$ ,  $\overline{AS}$ ,  $\overline{RD}$ ,  $\overline{HWR}$ , and  $\overline{LWR}$ ) retain their output state or go to the high-impedance state in software standby mode and watch mode, and in a direct transition.

**Bit 3**

OPE	Description
0	In software standby mode, watch mode, and in a direct transition, address bus and bus control signals are high-impedance
1	In software standby mode, watch mode, and in a direct transition, address bus and bus control signals retain their output state (Initial value)

**19.2.2 System Clock Control Register (SCKCR)**

Bit	:	7	6	5	4	3	2	1	0
		PSTOP	—	—	—	—	SCK2	SCK1	SCK0
Initial value	:	0	0	0	0	0	0	0	0
R/W	:	R/W	R/W	R/W	R/W	R/W	R/W	R/W	R/W

SCKCR is an 8-bit readable/writable register that performs  $\phi$  clock output control and medium-speed mode control.

SCKCR is initialized to H'00 by a reset and in hardware standby mode. It is not initialized in software standby mode.

**Bit 7— $\phi$  Clock Output Disable (PSTOP):** Controls  $\phi$  output.

Bit 7	Description			
PSTOP	High-Speed Mode, Medium-Speed Mode, Subactive Mode	Sleep Mode, Subsleep Mode	Software Standby Mode, Watch Mode, Direct Transition	Hardware Standby Mode
0	$\phi$ output (Initial value)	$\phi$ output	Fixed high	High impedance
1	Fixed high	Fixed high	Fixed high	High impedance

**Bits 6 to 3—Reserved:** These bits should always be written with 0, and are always read as 0.

**Bits 2 to 0—System Clock Select 2 to 0 (SCK2 to SCK0):** These bits select the clock for the bus master in high-speed mode and medium-speed mode. When operating the device after a transition to subactive mode or watch mode, bits SCK2 to SCK0 should all be cleared to 0.

Bit 2	Bit 1	Bit 0	Description
SCK2	SCK1	SCK0	
0	0	0	Bus master is in high-speed mode (Initial value)
		1	Medium-speed clock is $\phi/2$
	1	0	Medium-speed clock is $\phi/4$
		1	Medium-speed clock is $\phi/8$
1	0	0	Medium-speed clock is $\phi/16$
		1	Medium-speed clock is $\phi/32$
	1	—	—

### 19.2.3 Low-Power Control Register (LPWRCCR)

Bit	:	7	6	5	4	3	2	1	0
		DTON	LSON	NESEL	SUBSTP	RFCUT	—	STC1	STC0
Initial value	:	0	0	0	0	0	0	0	0
R/W	:	R/W	R/W	R/W	R/W	R/W	R/W	R/W	R/W

LPWRCCR is an 8-bit readable/writable register that performs power-down mode control.

LPWRCCR is initialized to H'00 by a power-on reset and in hardware standby mode. It is not initialized in software standby mode. Only bits 7 to 4 are described here; for details of the other bits, see section 18.2.2, Low-Power Control Register (LPWRCCR).

**Bit 7—Direct-Transfer On Flag (DTON):** Specifies whether a direct transition is made between high-speed mode, medium-speed mode, and subactive mode when making a power-down transition by executing a SLEEP instruction. The operating mode to which the transition is made after SLEEP instruction execution is determined by a combination of other control bits.



## Bit 7

DTON	Description
0	When a SLEEP instruction is executed in high-speed mode or medium-speed mode, a transition is made to sleep mode, software standby mode, or watch mode* When a SLEEP instruction is executed in subactive mode, a transition is made to subsleep mode or watch mode (Initial value)
1	When a SLEEP instruction is executed in high-speed mode or medium-speed mode, a transition is made directly to subactive mode*, or a transition is made to sleep mode or software standby mode When a SLEEP instruction is executed in subactive mode, a transition is made directly to high-speed mode, or a transition is made to subsleep mode

Note: \*When a transition is made to watch mode or subactive mode, high-speed mode must be set.

**Bit 6—Low-Speed On Flag (LSON):** Determines the operating mode in combination with other control bits when making a power-down transition by executing a SLEEP instruction. Also controls whether a transition is made to high-speed mode or medium-speed mode, or to subactive mode when watch mode is cleared.

## Bit 6

LSON	Description
0	When a SLEEP instruction is executed in high-speed mode or medium-speed mode, a transition is made to sleep mode, software standby mode, or watch mode* When a SLEEP instruction is executed in subactive mode, a transition is made to watch mode, or directly to high-speed mode After watch mode is cleared, a transition is made to high-speed mode (Initial value)
1	When a SLEEP instruction is executed in high-speed mode a transition is made to watch mode or subactive mode* When a SLEEP instruction is executed in subactive mode, a transition is made to subsleep mode or watch mode After watch mode is cleared, a transition is made to subactive mode

Note: \*When a transition is made to watch mode or subactive mode, high-speed mode must be set.

**Bit 5—Noise Elimination Sampling Frequency Select (NESEL):** Selects the frequency at which the subclock ( $\phi_{SUB}$ ) generated by the subclock oscillator is sampled with the clock ( $\phi$ ) generated by the system clock oscillator. When  $\phi = 5$  MHz or higher, clear this bit to 0.

**Bit 5**

NESEL	Description	
0	Sampling at $\phi$ divided by 8	(Initial value)
1	Sampling at $\phi$ divided by 4	

**Bit 4—Subclock Oscillator Control (SUBSTP):** Controls operation and stopping of the subclock oscillator.

**Bit 4**

SUBSTP	Description	
0	Subclock oscillator operates	(Initial value)
1	Subclock oscillator is stopped	

Note: When the subclock is not used, this bit should be set to 1.

**19.2.4 Timer Control/Status Register (TCSR)**

**WDT1 TCSR**

Bit	:	7	6	5	4	3	2	1	0
		OVF	WT/IT	TME	PSS	RST/NMI	CKS2	CKS1	CKS0
Initial value	:	0	0	0	0	0	0	0	0
R/W	:	R/(W)*	R/W	R/W	R/W	R/W	R/W	R/W	R/W

Note: \* Only 0 can be written in bit 7, to clear the flag.

TCSR is an 8-bit readable/writable register that performs selection of the WDT1 TCNT input clock, mode, etc.

Only bit 4 is described here. For details of the other bits, see section 12.2.2, Timer Control/Status Register (TCSR).

TCSR is initialized to H'00 by a reset and in hardware standby mode. It is not initialized in software standby mode.

**Bit 4—Prescaler Select (PSS):** Selects the WDT1 TCNT input clock.

This bit also controls the operation in a power-down mode transition. The operating mode to which a transition is made after execution of a SLEEP instruction is determined in combination

with other control bits.

For details, see the description of Clock Select 2 to 0 in section 12.2.2, Timer Control/Status Register (TCSR).

#### Bit 4

PSS	Description
0	TCNT counts $\phi$ -based prescaler (PSM) divided clock pulses When a SLEEP instruction is executed in high-speed mode or medium-speed mode, a transition is made to sleep mode or software standby mode (Initial value)
1	TCNT counts $\phi$ SUB-based prescaler (PSS) divided clock pulses When a SLEEP instruction is executed in high-speed mode or medium-speed mode, a transition is made to sleep mode, watch mode*, or subactive mode* When a SLEEP instruction is executed in subactive mode, a transition is made to subsleep mode, watch mode, or high-speed mode

Note: \* When a transition is made to watch mode or subactive mode, high-speed mode must be set.

### 19.2.5 Module Stop Control Register (MSTPCR)

#### MSTPCRA

Bit	:	7	6	5	4	3	2	1	0
		MSTPA7	MSTPA6	MSTPA5	MSTPA4	MSTPA3	MSTPA2	MSTPA1	MSTPA0
Initial value	:	0	0	1	1	1	1	1	1
R/W	:	R/W	R/W	R/W	R/W	R/W	R/W	R/W	R/W

#### MSTPCRB

Bit	:	7	6	5	4	3	2	1	0
		MSTPB7	MSTPB6	MSTPB5	MSTPB4	MSTPB3	MSTPB2	MSTPB1	MSTPB0
Initial value	:	1	1	1	1	1	1	1	1
R/W	:	R/W	R/W	R/W	R/W	R/W	R/W	R/W	R/W

#### MSTPCRC

Bit	:	7	6	5	4	3	2	1	0
		MSTPC7	MSTPC6	MSTPC5	MSTPC4	MSTPC3	MSTPC2	MSTPC1	MSTPC0
Initial value	:	1	1	1	1	1	1	1	1
R/W	:	R/W	R/W	R/W	R/W	R/W	R/W	R/W	R/W

MSTPCRA, MSTPCRB, and MSTPCRC are 8-bit readable/writable registers that perform module

stop mode control.

MSTPCRA is initialized to H'3F by a reset and in hardware standby mode. MSTPCRB and MSTPCRC are initialized to H'FF. They are not initialized in software standby mode.

**MSTPCRA, MSTPCRB, and MSTPCRC Bits 7 to 0—Module Stop (MSTPA7 to MSTPA0, MSTPB7 to MSTPB0, and MSTPC7 to MSTPC0):** These bits specify module stop mode. See table 19.4 for the method of selecting on-chip supporting modules.

**MSTPCRA, MSTPCRB, and MSTPCRC  
Bits 7 to 0**

<b>MSTPA7 to MSTPA0, MSTPB7 to MSTPB0, and MSTPC7 to MSTPC0</b>	<b>Description</b>
0	Module stop mode is cleared (Initial value of MSTPA7, MSTPA6)
1	Module stop mode is set (Initial value of except MSTPA7 to MSTPA6)

### 19.3 Medium-Speed Mode

When the SCK2 to SCK0 bits in SCKCR are set to 1 in high-speed mode, the operating mode changes to medium-speed mode at the end of the bus cycle. In medium-speed mode, the CPU operates on the operating clock ( $\phi/2$ ,  $\phi/4$ ,  $\phi/8$ ,  $\phi/16$ , or  $\phi/32$ ) specified by the SCK2 to SCK0 bits. The bus master other than the CPU (the DTC) also operates in medium-speed mode. On-chip supporting modules other than the bus masters always operate on the high-speed clock ( $\phi$ ).

In medium-speed mode, a bus access is executed in the specified number of states with respect to the bus master operating clock. For example, if  $\phi/4$  is selected as the operating clock, on-chip memory is accessed in 4 states, and internal I/O registers in 8 states.

Medium-speed mode is cleared by clearing all of bits SCK2 to SCK0 to 0. A transition is made to high-speed mode and medium-speed mode is cleared at the end of the current bus cycle.

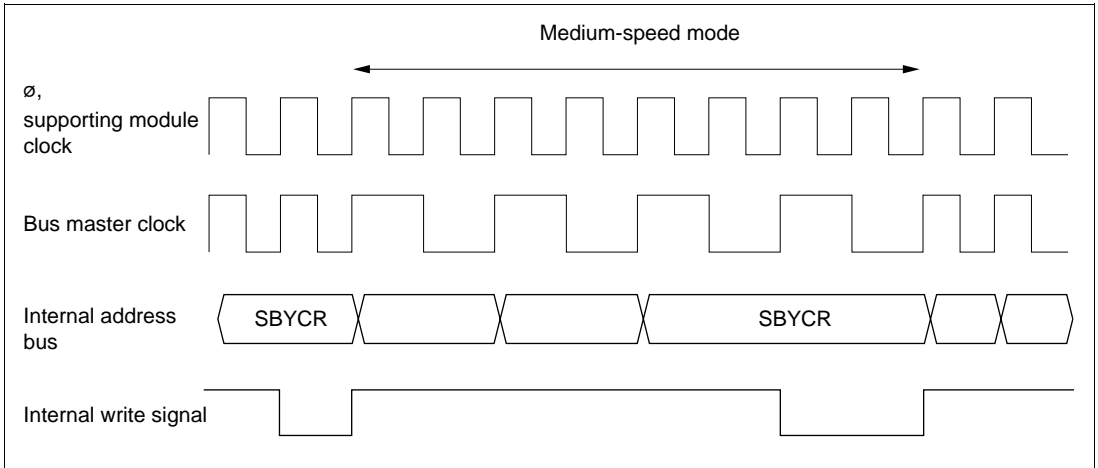
If a SLEEP instruction is executed when the SSBY bit in SBYCR and the LSON bit in LPWRCR are cleared to 0, a transition is made to sleep mode. When sleep mode is cleared by an interrupt, medium-speed mode is restored.

If a SLEEP instruction is executed when the SSBY bit in SBYCR is set to 1, and the LSON bit in LPWRCR and the PSS bit in TCSR (WDT1) are both cleared to 0, a transition is made to software standby mode. When software standby mode is cleared by an external interrupt, medium-speed mode is restored.

When the  $\overline{\text{RES}}$  pin is driven low, a transition is made to the reset state, and medium-speed mode is cleared. The same applies in the case of a reset caused by overflow of the watchdog timer.

When the  $\overline{\text{STBY}}$  pin is driven low, a transition is made to hardware standby mode.

Figure 19.2 shows the timing for transition to and clearance of medium-speed mode.



**Figure 19.2 Medium-Speed Mode Transition and Clearance Timing**

## 19.4 Sleep Mode

### 19.4.1 Sleep Mode

If a SLEEP instruction is executed when the SSBY bit in SBYCR and the LSON bit in LPWRCR are both cleared to 0, the CPU enters sleep mode. In sleep mode, CPU operation stops but the contents of the CPU's internal registers are retained. Other supporting modules do not stop.

### 19.4.2 Clearing Sleep Mode

Sleep mode is cleared by all interrupts, or with the  $\overline{\text{RES}}$  pin or  $\overline{\text{STBY}}$  pin.

**Clearing with an Interrupt:** When an interrupt request signal is input, sleep mode is cleared and interrupt exception handling is started. Sleep mode will not be cleared if interrupts are disabled, or if interrupts other than NMI have been masked by the CPU.

**Clearing with the  $\overline{\text{RES}}$  Pin:** When the  $\overline{\text{RES}}$  pin is driven low, the reset state is entered. When the  $\overline{\text{RES}}$  pin is driven high after the prescribed reset input period, the CPU begins reset exception handling.

**Clearing with the  $\overline{\text{STBY}}$  Pin:** When the  $\overline{\text{STBY}}$  pin is driven low, a transition is made to hardware standby mode.

## 19.5 Module Stop Mode

### 19.5.1 Module Stop Mode

Module stop mode can be set for individual on-chip supporting modules.

When the corresponding MSTP bit in MSTPCR is set to 1, module operation stops at the end of the bus cycle and a transition is made to module stop mode. The CPU continues operating independently.

Table 19.4 shows MSTP bits and the corresponding on-chip supporting modules.

When the corresponding MSTP bit is cleared to 0, module stop mode is cleared and the module starts operating again at the end of the bus cycle. In module stop mode, the internal states of modules other than the A/D converter are retained.

After reset release, all modules other than the DTC are in module stop mode.

When an on-chip supporting module is in module stop mode, read/write access to its registers is disabled.

When a transition is made to sleep mode with all modules stopped (MSTPCR = H'FFFFFF), the bus controller and I/O ports also stop operating, enabling current dissipation to be further reduced.

**Table 19.4 MSTP Bits and Corresponding On-Chip Supporting Modules**

Register	Bit	Module
MSTPCRA	MSTPA7	—*
	MSTPA6	Data transfer controller (DTC)
	MSTPA5	16-bit timer pulse unit (TPU)
	MSTPA4	8-bit timers (TMR0, TMR1)
	MSTPA3	—*
	MSTPA2	—*
	MSTPA1	A/D converter
	MSTPA0	—*
MSTPCRB	MSTPB7	Serial communication interface 0 (SCI0)
	MSTPB6	Serial communication interface 1 (SCI1)
	MSTPB5	—*
	MSTPB4	—*
	MSTPB3	—*
	MSTPB2	—*
	MSTPB1	—*
	MSTPB0	—*
MSTPCRC	MSTPC7	Serial communication interface 3 (SCI3)
	MSTPC6	—*
	MSTPC5	—*
	MSTPC4	PC break controller (PBC)
	MSTPC3	—*
	MSTPC2	—*
	MSTPC1	—*
	MSTPC0	—*

Note: \* Reserved.

### 19.5.2 Usage Note

**DTC Module Stop Mode:** Depending on the operating status of the DTC, the MSTPA6 bit may not be set to 1. Setting of the DTC module stop mode should be carried out only when the DTC is not activated.

For details, see section 8, Data Transfer Controller (DTC).

**On-Chip Supporting Module Interrupts:** Relevant interrupt operations cannot be performed in module stop mode. Consequently, if module stop mode is entered when an interrupt has been

requested, it will not be possible to clear the CPU interrupt source or DTC activation source. Interrupts should therefore be disabled before setting module stop mode.

**Writing to MSTPCR:** MSTPCR should be written to only by the CPU.

## 19.6 Software Standby Mode

### 19.6.1 Software Standby Mode

If a SLEEP instruction is executed when the SSBY bit in SBYCR is set to 1, the LSON bit in LPWRCR is cleared to 0, and the PSS bit in TCSR (WDT1) is cleared to 0, software standby mode is entered. In this mode, the CPU, on-chip supporting modules, and system clock oscillator all stop. However, the contents of the CPU's internal registers, RAM data, and the states of on-chip supporting module other than the A/D converter, and of the I/O ports, are retained. The address bus and bus control signals are placed in the high-impedance state.

In this mode the oscillator stops, and therefore power dissipation is significantly reduced.

### 19.6.2 Clearing Software Standby Mode

Software standby mode is cleared by an external interrupt (NMI pin, or pins  $\overline{\text{IRQ0}}$  to  $\overline{\text{IRQ7}}$ ), or by means of the  $\overline{\text{RES}}$  pin or  $\overline{\text{STBY}}$  pin.

**Clearing with an Interrupt:** When an NMI or IRQ0 to IRQ7 interrupt request signal is input, clock oscillation starts, and after the elapse of the time set in bits STS2 to STS0 in SYSCR, stable clocks are supplied to the entire chip, software standby mode is cleared, and interrupt exception handling is started.

When software standby mode is cleared with an IRQ0 to IRQ7 interrupt, set the corresponding enable bit to 1 and ensure that an interrupt of higher priority than interrupts IRQ0 to IRQ7 is not generated. Software standby mode cannot be cleared if the interrupt has been masked by the CPU side or has been designated as a DTC activation source.

**Clearing with the  $\overline{\text{RES}}$  Pin:** When the  $\overline{\text{RES}}$  pin is driven low, clock oscillation is started. At the same time as clock oscillation starts, clocks are supplied to the entire chip. Note that the  $\overline{\text{RES}}$  pin must be held low until clock oscillation stabilizes. When the  $\overline{\text{RES}}$  pin goes high, the CPU begins reset exception handling.

**Clearing with the  $\overline{\text{STBY}}$  Pin:** When the  $\overline{\text{STBY}}$  pin is driven low, a transition is made to hardware standby mode.



### 19.6.3 Setting Oscillation Stabilization Time after Clearing Software Standby Mode

Bits STS2 to STS0 in SBYCR should be set as described below.

**Using a Crystal Oscillator:** Set bits STS2 to STS0 so that the standby time is at least 8 ms (the oscillation stabilization time).

Table 19.5 shows the standby times for different operating frequencies and settings of bits STS2 to STS0.

**Table 19.5 Oscillation Stabilization Time Settings**

STS2	STS1	STS0	Standby Time	13 MHz	10 MHz	8 MHz	6 MHz	4 MHz	2 MHz	Unit
0	0	0	8192 states	0.6	0.8	1.0	1.3	2.0	4.1	ms
		1	16384 states	1.3	1.6	2.0	2.7	4.1	8.2	
	1	0	32768 states	2.5	3.3	4.1	5.5	8.2	16.4	
		1	65536 states	5.0	6.6	8.2	10.9	16.4	32.8	
1	0	0	131072 states	10.1	13.1	16.4	21.8	32.8	65.5	
		1	262144 states	20.2	26.2	32.8	43.6	65.6	131.2	
	1	0	Reserved	—	—	—	—	—	—	—
		1	16 states	1.2	1.6	2.0	1.7	4.0	8.0	μs

  : Recommended time setting

**Using an External Clock:** Any value can be set. Normally, use of the minimum time is recommended.

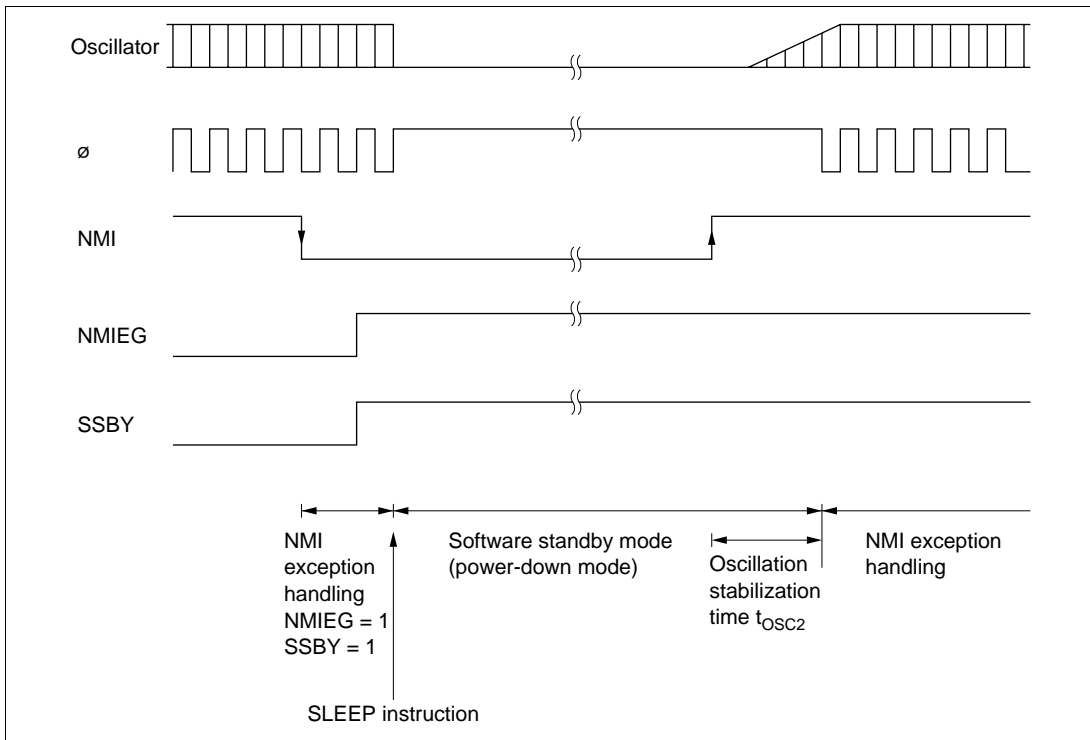
Note: A 16-state standby time cannot be used in the F-ZTAT version; a standby time of 8192 states or longer should be used.

### 19.6.4 Software Standby Mode Application Example

Figure 19.3 shows an example in which a transition is made to software standby mode at the falling edge on the NMI pin, and software standby mode is cleared at the rising edge on the NMI pin.

In this example, an NMI interrupt is accepted with the NMIEG bit in SYSCR cleared to 0 (falling edge specification), then the NMIEG bit is set to 1 (rising edge specification), the SSBY bit is set to 1, and a SLEEP instruction is executed, causing a transition to software standby mode.

Software standby mode is then cleared at the rising edge on the NMI pin.



**Figure 19.3 Software Standby Mode Application Example**

## 19.6.5 Usage Notes

**I/O Port States:** In software standby mode, I/O port states are retained. If the OPE bit is set to 1, the address bus and bus control signal output is also retained. Therefore, there is no reduction in current dissipation for the output current when a high-level signal is output.

**Current Dissipation During the Oscillation Stabilization Wait Period:** Current dissipation increases during the oscillation stabilization wait period.

## 19.7 Hardware Standby Mode

### 19.7.1 Hardware Standby Mode

When the  $\overline{STBY}$  pin is driven low, a transition is made to hardware standby mode from any mode.

In hardware standby mode, all functions enter the reset state and stop operation, resulting in a significant reduction in power dissipation. As long as the prescribed voltage is supplied, on-chip RAM data is retained. I/O ports are set to the high-impedance state.

In order to retain on-chip RAM data, the RAME bit in SYSCR should be cleared to 0 before driving the  $\overline{\text{STBY}}$  pin low.

Do not change the state of the mode pins (MD2 to MD0) while the LSI is in hardware standby mode.

Hardware standby mode is cleared by means of the  $\overline{\text{STBY}}$  pin and the  $\overline{\text{RES}}$  pin. When the  $\overline{\text{STBY}}$  pin is driven high while the  $\overline{\text{RES}}$  pin is low, the reset state is set and clock oscillation is started. Ensure that the  $\overline{\text{RES}}$  pin is held low until the clock oscillation stabilizes (at least  $t_{\text{OSC1}}$ —the oscillation stabilization time—when using a crystal oscillator). When the  $\overline{\text{RES}}$  pin is subsequently driven high, a transition is made to the program execution state via the reset exception handling state.

### 19.7.2 Hardware Standby Mode Timing

Figure 19.4 shows an example of hardware standby mode timing.

When the  $\overline{\text{STBY}}$  pin is driven low after the  $\overline{\text{RES}}$  pin has been driven low, a transition is made to hardware standby mode. Hardware standby mode is cleared by driving the  $\overline{\text{STBY}}$  pin high, waiting for the oscillation stabilization time, then changing the RES pin from low to high.

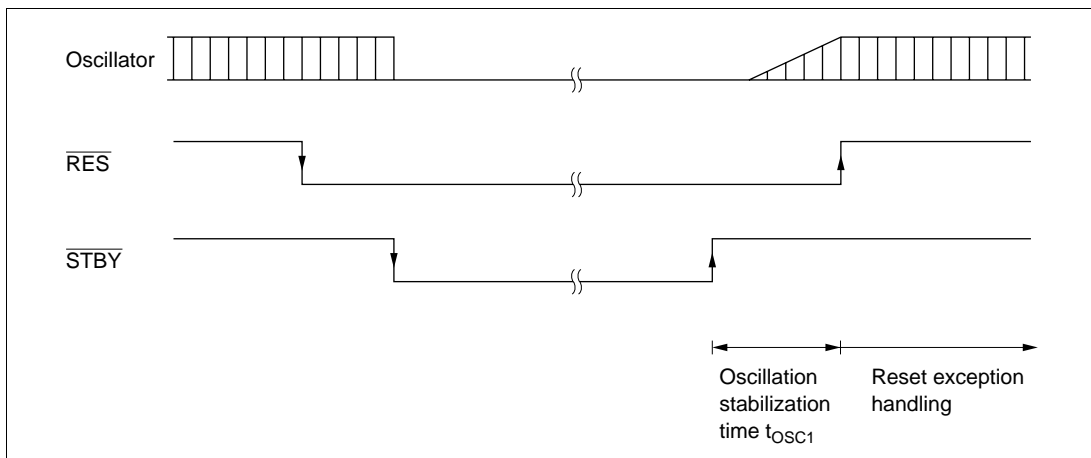


Figure 19.4 Hardware Standby Mode Timing (Example)

## 19.8 Watch Mode

### 19.8.1 Watch Mode

If a SLEEP instruction is executed in high-speed mode or subactive mode when the SSBY in SBYCR is set to 1, the DTON bit in LPWRCR is cleared to 0, and the PSS bit in TCSR (WDT1) is set to 1, the CPU makes a transition to watch mode.

In this mode, the CPU, all on-chip supporting modules except WDT1 and system clock oscillator stop. The contents of CPU internal registers and on-chip RAM, and the states of the on-chip supporting functions (except the A/D converter) and I/O ports, are retained. The address bus and bus control signals go to the high-impedance state. When a transition is made to watch mode, bits SCK2 to SCK0 in SCKCR must all be cleared to 0.

### 19.8.2 Clearing Watch Mode

Watch mode is cleared by an interrupt (WOVI1 interrupt, NMI pin, or pins  $\overline{\text{IRQ0}}$  to  $\overline{\text{IRQ7}}$ ), or by means of the  $\overline{\text{RES}}$  pin or  $\overline{\text{STBY}}$  pin.

**Clearing with an Interrupt:** When an interrupt request signal is input, watch mode is cleared and a transition is made to high-speed mode or medium-speed mode if the LSON bit in LPWRCR is cleared to 0, or to subactive mode if the LSON bit is set to 1. When making a transition to high-speed mode, after the elapse of the time set in bits STS2 to STS0 in SBYCR, stable clocks are supplied to the entire chip, and interrupt exception handling is started.

Watch mode cannot be cleared with an IRQ0 to IRQ7 interrupt if the corresponding enable bit has been cleared to 0, or with an on-chip supporting module interrupt if acceptance of the relevant interrupt has been disabled by the interrupt enable register or masked by the CPU.

See section 19.6.3, Setting Oscillation Stabilization Time after Clearing Software Standby Mode, for the oscillation stabilization time setting when making a transition from watch mode to high-speed mode.

**Clearing with the  $\overline{\text{RES}}$  Pin:** See “Clearing with the  $\overline{\text{RES}}$  Pin” in section 19.6.2, Clearing Software Standby Mode.

**Clearing with the  $\overline{\text{STBY}}$  Pin:** When the  $\overline{\text{STBY}}$  pin is driven low, a transition is made to hardware standby mode.

### 19.8.3 Usage Notes

**I/O Port States:** In watch mode, I/O port states are retained. If the OPE bit is set to 1, address bus and bus control signal output is also retained. Therefore, there is no reduction in current dissipation for the output current when a high-level signal is output.

**Current Dissipation during the Oscillation Stabilization Wait Period:** Current dissipation increases during the oscillation stabilization wait period.

## 19.9 Subsleep Mode

### 19.9.1 Subsleep Mode

If a SLEEP instruction is executed in subactive mode when the SSBY in SBYCR is cleared to 0, the LSON bit in LPWRCR is set to 1, and the PSS bit in TCSR (WDT1) is set to 1, the CPU makes a transition to subsleep mode.

In this mode, the CPU, all on-chip supporting modules except TMR0, TMR1, WDT0, and WDT1 and system clock oscillator stop. The contents of CPU internal registers and on-chip RAM, and the states of the on-chip supporting functions (except the A/D converter) and I/O ports, are retained.

### 19.9.2 Clearing Subsleep Mode

Subsleep mode is cleared by an interrupt (on-chip supporting module interrupt, NMI pin, or pin  $\overline{\text{IRQ0}}$  to  $\overline{\text{IRQ7}}$ ), or by means of the  $\overline{\text{RES}}$  pin or  $\overline{\text{STBY}}$  pin.

**Clearing with an Interrupt:** When an interrupt request signal is input, subsleep mode is cleared and interrupt exception handling is started. Subsleep mode cannot be cleared with an  $\overline{\text{IRQ0}}$  to  $\overline{\text{IRQ7}}$  interrupt if the corresponding enable bit has been cleared to 0, or with an on-chip supporting module interrupt if acceptance of the relevant interrupt has been disabled by the interrupt enable register or masked by the CPU.

**Clearing with the  $\overline{\text{RES}}$  Pin:** See “Clearing with the  $\overline{\text{RES}}$  Pin” in section 19.6.2, Clearing Software Standby Mode.

**Clearing with the  $\overline{\text{STBY}}$  Pin:** When the  $\overline{\text{STBY}}$  pin is driven low, a transition is made to hardware standby mode.

## 19.10 Subactive Mode

### 19.10.1 Subactive Mode

If a SLEEP instruction is executed in high-speed mode when the SSBY bit in SBYCR, the DTON bit in LPWRCCR, and the PSS bit in TCSR (WDT1) are all set to 1, the CPU makes a transition to subactive mode. When an interrupt is generated in watch mode, if the LSON bit in LPWRCCR is set to 1, a transition is made to subactive mode. When an interrupt is generated in subsleep mode, a transition is made to subactive mode.

In subactive mode, the CPU performs sequential program execution at low speed on the subclock. In this mode, all on-chip supporting modules except PBC, TMR0, TMR1, WDT0, and WDT1, and system clock oscillator stop.

When operating the device in subactive mode, bits SCK2 to SCK0 in SBYCR must all be cleared to 0.

### 19.10.2 Clearing Subactive Mode

Subactive mode is cleared by a SLEEP instruction, or by means of the  $\overline{\text{RES}}$  pin or  $\overline{\text{STBY}}$  pin.

**Clearing with a SLEEP Instruction:** When a SLEEP instruction is executed while the SSBY bit in SBYCR is set to 1, the DTON bit in LPWRCCR is cleared to 0, and the PSS bit in TCSR (WDT1) is set to 1, subactive mode is cleared and a transition is made to watch mode. When a SLEEP instruction is executed while the SSBY bit in SBYCR is cleared to 0, the LSON bit in LPWRCCR is set to 1, and the PSS bit in TCSR (WDT1) is set to 1, a transition is made to subsleep mode. When a SLEEP instruction is executed while the SSBY bit in SBYCR is set to 1, the DTON bit is set to 1 and the LSON bit is cleared to 0 in LPWRCCR, and the PSS bit in TCSR (WDT1) is set to 1, a transition is made directly to high-speed mode (SCK0 to SCK2 all 0).

For details of direct transition, see section 19.11, Direct Transition.

**Clearing with the  $\overline{\text{RES}}$  Pin:** See "Clearing with the  $\overline{\text{RES}}$  Pin" in section 19.6.2, Clearing Software Standby Mode.

**Clearing with the  $\overline{\text{STBY}}$  Pin:** When the  $\overline{\text{STBY}}$  pin is driven low, a transition is made to hardware standby mode

## 19.11 Direct Transition

### 19.11.1 Overview of Direct Transition

There are three operating modes in which the CPU executes programs: high-speed mode, medium-speed mode, and subactive mode. A transition between high-speed mode and subactive mode without halting the program is called a direct transition. A direct transition can be carried out by setting the DTON bit in LPWRCR to 1 and executing a SLEEP instruction. After the transition, direct transition interrupt exception handling is started.

**Direct Transition from High-Speed Mode to Subactive Mode:** If a SLEEP instruction is executed in high-speed mode while the SSBY bit in SBYCR, the LSON bit and DTON bit in LPWRCR, and the PSS bit in TSCR (WDT1) are all set to 1, a transition is made to subactive mode.

**Direct Transition from Subactive Mode to High-Speed Mode:** If a SLEEP instruction is executed in subactive mode while the SSBY bit in SBYCR is set to 1, the LSON bit is cleared to 0 and the DTON bit is set to 1 in LPWRCR, and the PSS bit in TSCR (WDT1) is set to 1, after the elapse of the time set in bits STS2 to STS0 in SBYCR, a transition is made to directly to high-speed mode.

## 19.12 $\emptyset$ Clock Output Disabling Function

Output of the  $\emptyset$  clock can be controlled by means of the PSTOP bit in SCKCR and the corresponding DDR bit. When the PSTOP bit is set to 1, the  $\emptyset$  clock is stopped at the end of the bus cycle, and  $\emptyset$  output goes high.  $\emptyset$  clock output is enabled when PSTOP bit is cleared to 0. When DDR for the corresponding port is cleared to 0,  $\emptyset$  clock output is disabled and input port mode is set. Table 19.6 shows the state of the  $\emptyset$  pin in each processing mode.

**Table 19.6  $\emptyset$  Pin State in Each Processing Mode**

DDR	0	1	1
PSTOP	—	0	1
Hardware standby mode	High Impedance	High Impedance	High Impedance
Software standby mode, watch mode, direct transition	High Impedance	Fixed high	Fixed high
Sleep mode, subsleep mode	High Impedance	$\emptyset$ output	Fixed high
High-speed mode, medium-speed mode, subactive mode	High Impedance	$\emptyset$ output	Fixed high

## 19.13 Usage Notes

### 19.13.1 I/O Port Status

In software standby mode and watch mode, I/O port states are retained. Therefore, there is no reduction in current dissipation for the output current when a high-level signal is output.

### 19.13.2 Current Dissipation during Oscillation Stabilization Wait Period

Current dissipation increases during the oscillation stabilization wait period.

### 19.13.3 DTC Module Stop

Depending on the operating status of the DTC, the MSTPA6 bit may not be set to 1. Setting of the DTC module stop mode should be carried out only when the respective module is not activated.

For details, refer to section 8, Data Transfer Controller (DTC).

### 19.13.4 On-Chip Supporting Module Interrupt

- Module stop mode  
Relevant interrupt operations cannot be performed in module stop mode. Consequently, if module stop mode is entered when an interrupt has been requested, it will not be possible to clear the CPU interrupt source or the DTC activation source. Interrupts should therefore be disabled before entering module stop mode.
- Subactive mode/Watch mode  
On-chip peripheral modules (DTC, TPU) that stop operation in subactive mode cannot clear interrupts in subactive mode. Therefore, if subactive mode is entered when an interrupt is requested, CPU interrupt factors cannot be cleared.  
Interrupts should therefore be disabled before executing the SLEEP instruction and entering subactive or watch mode.

### 19.13.5 Writing to MSTPCR

MSTPCR should only be written to by the CPU.



### 19.13.6 Entering Subactive/Watch Mode and DTC Module Stop

To enter subactive or watch mode, set DTC to module stop (write 1 to the MSTPA6 bit) and reading the MSTPA6 bit as 1 before transiting mode. After transiting from subactive mode to active mode, clear module stop.

When DTC activation factor occurs in subactive mode, DTC is activated when module stop is cleared after active mode is entered.



# Section 20 Electrical Characteristics

## 20.1 Power Supply Voltage and Operating Frequency Range

Power supply voltage and operating frequency ranges (shaded areas) are shown in figure 20.1.

— Preliminary —

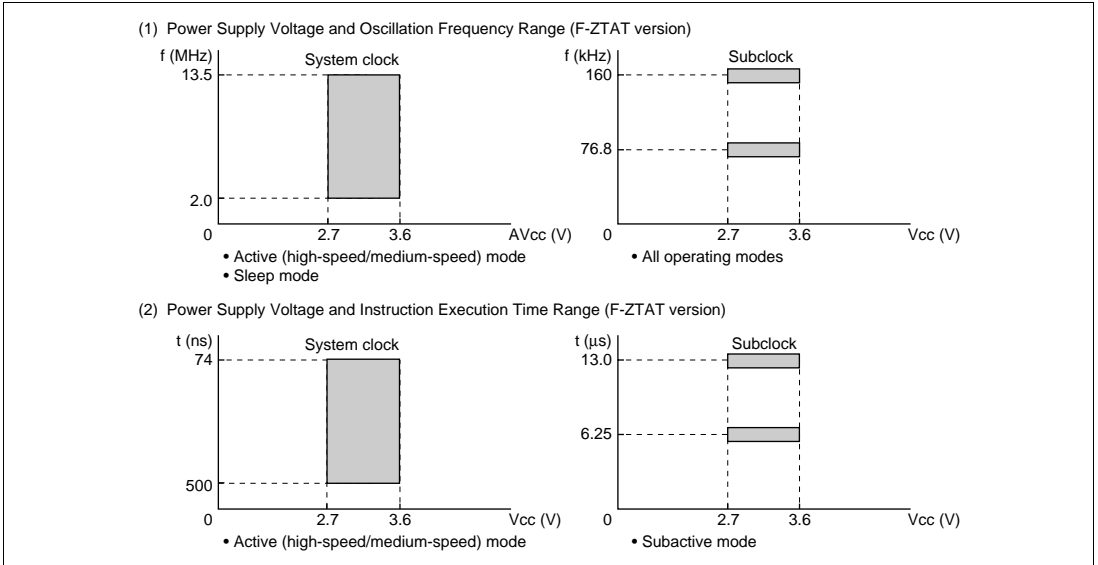


Figure 20.1 Power Supply Voltage and Operating Ranges

## 20.2 Electrical Characteristics

### 20.2.1 Absolute Maximum Ratings

Table 20.1 lists the absolute maximum ratings.

**Table 20.1 Absolute Maximum Ratings**

— Preliminary —

Item	Symbol	Value	Unit
Power supply voltage	$V_{CC}$	-0.3 to +4.3	V
Input voltage (except port 4, TESTD, LOBAT)	$V_{in}$	-0.3 to $V_{CC} + 0.3$	V
Input voltage (port 4, TESTD, LOBAT)	$V_{in}$	-0.3 to $AV_{CC} + 0.3$	V
Reference power supply voltage	$V_{ref}$	-0.3 to $AV_{CC} + 0.3$	V
Analog power supply voltage	$AV_{CC}$	-0.3 to +4.3	V
Analog input voltage	$V_{AN}$	-0.3 to $AV_{CC} + 0.3$	V
Operating temperature	$T_{opr}$	-20 to +75	°C
Storage temperature	$T_{stg}$	-55 to +125	°C

Caution: Permanent damage to the chip may result if absolute maximum ratings are exceeded.

## 20.2.2 DC Characteristics

DC characteristics are shown in table 20.2 and permissible output currents in table 20.3.

**Table 20.2 DC Characteristics (1)**

— Preliminary —

Conditions (F-ZTAT version):

$$V_{CC} = 2.7 \text{ V to } 3.6 \text{ V}, AV_{CC} = 2.7 \text{ V to } 3.6 \text{ V}, V_{ref} = 2.7 \text{ V to } AV_{CC},$$

$$V_{SS} = AV_{SS} = 0 \text{ V}, T_a = -20^\circ\text{C to } +75^\circ\text{C}^*$$

Item	Symbol	Min	Typ	Max	Unit	Test Conditions	
Schmitt trigger input voltage	$\overline{IRQ0}$ to $\overline{IRQ7}$	$V_{CC} \times 0.2$	—	—	V		
		—	—	$V_{CC} \times 0.8$	V		
		$V_{CC} \times 0.05$	—	—	V		
Input high voltage	$\overline{RES}$ , $\overline{STBY}$ , NMI, MD2 to MD0, FWE, IFIN	$V_{CC} \times 0.9$	—	$V_{CC} + 0.3$	V		
	EXTAL, ports 1, 3, A to G, EXTS0, EXTS1	$V_{CC} \times 0.8$	—	$V_{CC} + 0.3$	V		
	Port 4, TESTD, LOBAT	$V_{CC} \times 0.8$	—	$AV_{CC} + 0.3$	V		
Input low voltage	$\overline{RES}$ , $\overline{STBY}$ , MD2 to MD0, FWE, IFIN	-0.3	—	$V_{CC} \times 0.1$	V		
	NMI, EXTAL, ports 1, 3, 4, A to G, EXTS0, EXTS1, TESTD, LOBAT	-0.3	—	$V_{CC} \times 0.2$	V		
Output high voltage	All output pins	$V_{OH}$	$V_{CC} - 0.5$	—	—	V	$I_{OH} = -200 \mu\text{A}$
			$V_{CC} - 1.0$	—	—	V	$I_{OH} = -1 \text{ mA}$
Output low voltage	All output pins	$V_{OL}$	—	—	0.4	V	$I_{OL} = 0.4 \text{ mA}$
			—	—	0.4	V	$I_{OL} = 0.8 \text{ mA}$
Input leakage current	$\overline{RES}$	$ I_{in} $	—	—	1.0	$\mu\text{A}$	$V_{in} = 0.2$ to $V_{CC} - 0.2 \text{ V}$
	$\overline{STBY}$ , NMI, MD2 to MD0, FWE, IFIN, EXTS0, EXTS1		—	—	1.0	$\mu\text{A}$	
	Port 4, TESTD, LOBAT		—	—	1.0	$\mu\text{A}$	$V_{in} = 0.2$ to $AV_{CC} - 0.2 \text{ V}$

Item	Symbol	Min	Typ	Max	Unit	Test
						Conditions
Three-state leakage current (off state)	Ports 1, 3, A to G $ I_{TSL} $	—	—	1.0	$\mu\text{A}$	$V_{in} = 0.2$ to $V_{CC} - 0.2$ V
Input pull-up MOS current	Ports A to E $-I_p$	10	—	300	$\mu\text{A}$	$V_{in} = 0$ V

Note: \* **If the A/D converter is not used, do not leave the  $AV_{CC}$ ,  $V_{ref}$ , and  $AV_{SS}$  pins open.**  
 Apply a voltage between 2.0 V and 3.6 V to the  $AV_{CC}$  and  $V_{ref}$  pins by connecting them to  $V_{CC}$ , for instance. Set  $V_{ref} \leq AV_{CC}$ .

**Table 20.2 DC Characteristics (2)**

— Preliminary —

Conditions (F-ZTAT version):

$$V_{CC} = 2.7 \text{ V to } 3.6 \text{ V}, AV_{CC} = 2.7 \text{ V to } 3.6 \text{ V}, V_{ref} = 2.7 \text{ V to } AV_{CC},$$

$$V_{SS} = AV_{SS} = 0 \text{ V}, T_a = -20^\circ\text{C to } +75^\circ\text{C}^{*1}$$

Item	Symbol	Min	Typ	Max	Unit	Test Conditions
Input capacitance	$\overline{RES}$	$C_{in}$	—	—	30	pF $V_{in} = 0 \text{ V}$
	NMI	—	—	30	pF	$f = 1 \text{ MHz}$
	All input pins except the above	—	—	15	pF	$T_a = 25^\circ\text{C}$
Current dissipation* <sup>2</sup>	Normal operation	$I_{CC}^{*4}$	—	13 $V_{CC} = 3.0 \text{ V}$	26 $V_{CC} = 3.6 \text{ V}$	mA $f = 13.5 \text{ MHz}$
	Sleep mode	—	—	9 $V_{CC} = 3.0 \text{ V}$	20 $V_{CC} = 3.6 \text{ V}$	mA $f = 13.5 \text{ MHz}$
	All modules stopped	—	—	12	—	mA $f = 13.5 \text{ MHz},$ $V_{CC} = 3.0 \text{ V}$ (reference values)
	Medium-speed mode ( $\emptyset/32$ )	—	—	9	—	mA $f = 13.5 \text{ MHz},$ $V_{CC} = 3.0 \text{ V}$ (reference values)
	Subactive mode	—	—	150	280	$\mu\text{A}$ Using 160 kHz crystal resonator $V_{CC} = 3.0 \text{ V}$
	Subsleep mode	—	—	120	230	$\mu\text{A}$ Using 160 kHz crystal resonator $V_{CC} = 3.0 \text{ V}$
	Watch mode	—	—	50	90	$\mu\text{A}$ Using 160 kHz crystal resonator $V_{CC} = 3.0 \text{ V}$
	Standby mode* <sup>3</sup>	—	—	0.01 $V_{CC} = 3.0 \text{ V}$	10 $V_{CC} = 3.6 \text{ V}$	$\mu\text{A}$
—		—	—	50 $V_{CC} = 3.6 \text{ V}$	—	$50^\circ\text{C} < T_a$ not using subclock

Item		Symbol	Min	Typ	Max	Unit	Test Conditions
Analog power supply current	During A/D conversion	$I_{CC}$	—	0.2	1.0	mA	$AV_{CC} = 3.0\text{ V}$
	Idle		—	0.01	5.0	$\mu\text{A}$	
Reference power supply current	During A/D conversion	$I_{CC}$	—	0.2	1.0	mA	$V_{ref} = 3.0\text{ V}$
	Idle		—	0.01	5.0	$\mu\text{A}$	
RAM standby voltage		$V_{RAM}$	2.0	—	—	V	

- Notes: \*1 **If the A/D converters is not used, do not leave the  $AV_{CC}$ ,  $V_{ref}$ , and  $AV_{SS}$  pins open.**  
Apply a voltage between 2.0 V and 3.6 V to the  $AV_{CC}$  and  $V_{ref}$  pins by connecting them to  $V_{CC}$ , for instance. Set  $V_{ref} \leq AV_{CC}$ .
- \*2 Current dissipation values are for  $V_{IH\ min} = V_{CC} - 0.2\text{ V}$  and  $V_{IL\ max} = 0.2\text{ V}$  with all output pins unloaded and all MOS input pull-ups in the off state.
- \*3 The values are for  $V_{RAM} \leq V_{CC} < 2.7\text{ V}$ ,  $V_{IH\ min} = V_{CC} - 0.2$ , and  $V_{IL\ max} = 0.2\text{ V}$ .
- \*4  $I_{CC}$  depends on  $V_{CC}$  and  $f$  as follows:  
 $I_{CC\ max} = 1.0\text{ (mA)} + 0.51\text{ (mA/(MHz}\cdot\text{V))} \times V_{CC} \times f$  (normal operation)  
 $I_{CC\ max} = 1.0\text{ (mA)} + 0.39\text{ (mA/(MHz}\cdot\text{V))} \times V_{CC} \times f$  (sleep mode)



Conditions (F-ZTAT version):

$$V_{CC} = 2.7 \text{ V to } 3.6 \text{ V}, AV_{CC} = 2.7 \text{ V to } 3.6 \text{ V}, V_{ref} = 2.7 \text{ V to } AV_{CC},$$

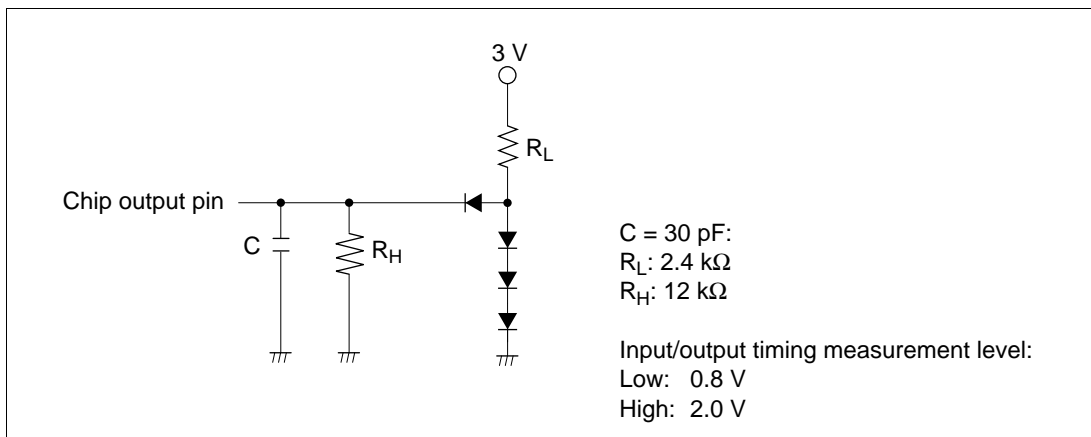
$$V_{SS} = AV_{SS} = 0 \text{ V}, T_a = -20^\circ\text{C to } +75^\circ\text{C}$$

Item		Symbol	Min	Typ	Max	Unit
Permissible output low current (per pin)	All output pins	$I_{OL}$	—	—	1.0	mA
Permissible output low current (total)	Total of all output pins	$\Sigma I_{OL}$	—	—	60	mA
Permissible output high current (per pin)	All output pins	$-I_{OH}$	—	—	1.0	mA
Permissible output high current (total)	Total of all output pins	$\Sigma -I_{OH}$	—	—	30	mA

Note: To protect chip reliability, do not exceed the output current values in table 20.3.

### 20.2.3 AC Characteristics

Figure 20.2 shows the AC test conditions.



**Figure 20.2 Output Load Circuit**

## Clock Timing

Table 20.4 shows the clock timing.

**Table 20.4 Clock Timing**

— Preliminary —

Conditions (F-ZTAT version):

$$V_{CC} = 2.7 \text{ V to } 3.6 \text{ V}, AV_{CC} = 2.7 \text{ V to } 3.6 \text{ V}, V_{ref} = 2.7 \text{ V to } AV_{CC}, V_{SS} = AV_{SS} = 0 \text{ V}, \\ \phi = 160 \text{ kHz, } 76.8 \text{ kHz, } 2 \text{ MHz to } 13.5 \text{ MHz, } T_a = -20^\circ\text{C to } +75^\circ\text{C}$$

Item	Symbol	Min	Typ	Max	Unit	Test Conditions
Clock cycle time	$t_{cyc}$	74	—	500	ns	Figure 20.3
Clock pulse high width	$t_{CH}$	25	—	—	ns	
Clock pulse low width	$t_{CL}$	25	—	—	ns	
Clock rise time	$t_{Cr}$	—	—	10	ns	
Clock fall time	$t_{Cf}$	—	—	10	ns	
Reset oscillation stabilization time (crystal)	$t_{OSC1}$	20	—	—	ms	Figure 20.4
Software standby oscillation stabilization time (crystal)	$t_{OSC2}$	8	—	—	ms	Figure 19.3
External clock output stabilization delay time	$t_{DEXT}$	500	—	—	$\mu\text{s}$	Figure 20.4
Subclock oscillation stabilization time	$t_{OSC3}$	—	—	2	s	
Subclock oscillator frequency	$f_{SUB}$	—	160, 76.8	—	kHz	
Subclock ( $\phi_{SUB}$ ) cycle time	$t_{SUB}$	—	6.25, 13.0	—	$\mu\text{s}$	

## Control Signal Timing

Table 20.5 shows the control signal timing.

**Table 20.5 Control Signal Timing**

—Preliminary—

Conditions (F-ZTAT version):

$V_{CC} = 2.7\text{ V to }3.6\text{ V}$ ,  $AV_{CC} = 2.7\text{ V to }3.6\text{ V}$ ,  $V_{ref} = 2.7\text{ V to }AV_{CC}$ ,  $V_{SS} = AV_{SS} = 0\text{ V}$ ,  
 $\phi = 160\text{ kHz, }76.8\text{ kHz, }2\text{ MHz to }13.5\text{ MHz}$ ,  $T_a = -20^\circ\text{C to }+75^\circ\text{C}$

Item	Symbol	Min	Max	Unit	Test Conditions
$\overline{\text{RES}}$ setup time	$t_{\text{RESS}}$	250	—	ns	Figure 20.5
$\overline{\text{RES}}$ pulse width	$t_{\text{RESW}}$	20	—	$t_{\text{cyc}}$	
NMI setup time	$t_{\text{NMIS}}$	250	—	ns	Figure 20.6
NMI hold time	$t_{\text{NMIH}}$	10	—		
NMI pulse width (in recovery from software standby mode)	$t_{\text{NMIW}}$	200	—		
$\overline{\text{IRQ}}$ setup time	$t_{\text{IRQS}}$	250	—	ns	
$\overline{\text{IRQ}}$ hold time	$t_{\text{IRQH}}$	10	—		
$\overline{\text{IRQ}}$ pulse width (in recovery from software standby mode)	$t_{\text{IRQW}}$	200	—		

## Bus Timing

Table 20.6 shows the bus timing.

**Table 20.6 Bus Timing**

— Preliminary —

Conditions (F-ZTAT version):

$$V_{CC} = 2.7 \text{ V to } 3.6 \text{ V}, AV_{CC} = 2.7 \text{ V to } 3.6 \text{ V}, V_{ref} = 2.7 \text{ V to } AV_{CC}, V_{SS} = AV_{SS} = 0 \text{ V}, \\ \phi = 2 \text{ MHz to } 13.5 \text{ MHz}, T_a = -20^\circ\text{C to } +75^\circ\text{C}$$

Item	Symbol	Min	Max	Unit	Test Conditions
Address delay time	$t_{AD}$	—	50	ns	Figure 20.7 to Figure 20.11
Address setup time	$t_{AS}$	$0.5 \times t_{cyc} - 30$	—	ns	
Address hold time	$t_{AH}$	$0.5 \times t_{cyc} - 15$	—	ns	
$\overline{CS}$ delay time	$t_{CSD}$	—	50	ns	
$\overline{AS}$ delay time	$t_{ASD}$	—	50	ns	
$\overline{RD}$ delay time 1	$t_{RSD1}$	—	50	ns	
$\overline{RD}$ delay time 2	$t_{RSD2}$	—	50	ns	
Read data setup time	$t_{RDS}$	30	—	ns	
Read data hold time	$t_{RDH}$	0	—	ns	
Read data access time 1	$t_{ACC1}$	—	$1.0 \times t_{cyc} - 65$	ns	
Read data access time 2	$t_{ACC2}$	—	$1.5 \times t_{cyc} - 65$	ns	
Read data access time 3	$t_{ACC3}$	—	$2.0 \times t_{cyc} - 65$	ns	
Read data access time 4	$t_{ACC4}$	—	$2.5 \times t_{cyc} - 65$	ns	
Read data access time 5	$t_{ACC5}$	—	$3.0 \times t_{cyc} - 65$	ns	
$\overline{WR}$ delay time 1	$t_{WRD1}$	—	50	ns	Figure 20.7
$\overline{WR}$ delay time 2	$t_{WRD2}$	—	50	ns	Figure 20.8
$\overline{WR}$ pulse width 1	$t_{WSW1}$	$1.0 \times t_{cyc} - 30$	—	ns	
$\overline{WR}$ pulse width 2	$t_{WSW2}$	$1.5 \times t_{cyc} - 30$	—	ns	
Write data delay time	$t_{WDD}$	—	70	ns	
Write data setup time	$t_{WDS}$	$0.5 \times t_{cyc} - 37$	—	ns	
Write data hold time	$t_{WDH}$	$0.5 \times t_{cyc} - 15$	—	ns	
$\overline{WAIT}$ setup time	$t_{WTS}$	50	—	ns	Figure 20.9
$\overline{WAIT}$ hold time	$t_{WTH}$	10	—	ns	
$\overline{BREQ}$ setup time	$t_{BRQS}$	50	—	ns	Figure 20.12
$\overline{BACK}$ delay time	$t_{BACD}$	—	50	ns	
Bus floating time	$t_{BZD}$	—	80	ns	

## Timing of On-Chip Supporting Modules

Table 20.7 shows the timing of the on-chip supporting modules.

**Table 20.7 Timing of On-Chip Supporting Modules**

— Preliminary —

Conditions (F-ZTAT version):

$V_{CC} = 2.7\text{ V to }3.6\text{ V}$ ,  $AV_{CC} = 2.7\text{ V to }3.6\text{ V}$ ,  $V_{ref} = 2.7\text{ V to }AV_{CC}$ ,  $V_{SS} = AV_{SS} = 0\text{ V}$ ,  
 $\phi = 160\text{ kHz, }76.8\text{ kHz, }2\text{ MHz to }13.5\text{ MHz}$ ,  $T_a = -20^{\circ}\text{C to }+75^{\circ}\text{C}$

Item		Symbol	Min	Max	Unit	Test Conditions	
I/O ports	Output data delay time	$t_{PWD}$	—	100	ns	Figure 20.13	
	Input data setup time	$t_{PRS}$	50	—			
	Input data hold time	$t_{PRH}$	50	—			
TPU	Timer output delay time	$t_{TOCD}$	—	100	ns	Figure 20.14	
	Timer input setup time	$t_{TICS}$	40	—			
	Timer clock input setup time	$t_{TCKS}$	40	—	ns	Figure 20.15	
	Timer clock pulse width	Single-edge $t_{TCKWH}$	1.5	—	$t_{cyc}$		
		Both-edge $t_{TCKWL}$	2.5	—			
WDT1	BUZZ output delay time	$t_{BUZD}$	—	100	ns	Figure 20.16	
SCI	Input clock cycle	Asynchronous	$t_{Seyc}$	4	—	$t_{cyc}$	Figure 20.17
		Synchronous		6	—		
	Input clock pulse width	$t_{SCKW}$	0.4	0.6	$t_{scyc}$		
	Input clock rise time	$t_{SCKr}$	—	1.5	$t_{cyc}$		
	Input clock fall time	$t_{SCKf}$	—	1.5			
	Transmit data delay time	$t_{TXD}$	—	100	ns	Figure 20.18	
	Receive data setup time (synchronous)	$t_{RXS}$	75	—	ns		
Receive data hold time (synchronous)	$t_{RXH}$	75	—	ns			
A/D converter	Trigger input setup time	$t_{TRGS}$	40	—	ns	Figure 20.19	

## 20.2.4 A/D Conversion Characteristics

Table 20.8 shows the A/D conversion characteristics.

**Table 20.8 A/D Conversion Characteristics**

— Preliminary —

Conditions (F-ZTAT version):

$V_{CC} = 2.7 \text{ V to } 3.6 \text{ V}$ ,  $AV_{CC} = 2.7 \text{ V to } 3.6 \text{ V}$ ,  $V_{ref} = 2.7 \text{ V to } AV_{CC}$ ,  $V_{SS} = AV_{SS} = 0 \text{ V}$ ,  
 $\phi = 2 \text{ MHz to } 13.5 \text{ MHz}$ ,  $T_a = -20^\circ\text{C to } +75^\circ\text{C}$

Item	Min	Typ	Max	Unit
Resolution	10	10	10	Bit
Conversion time	9.9	—	—	$\mu\text{s}$
Analog input capacitance	—	—	20	pF
Permissible signal source impedance	—	—	5	k $\Omega$
Nonlinearity error	—	—	$\pm 6.0$	LSB
Offset error	—	—	$\pm 4.0$	LSB
Full-scale error	—	—	$\pm 4.0$	LSB
Quantization error	—	—	$\pm 0.5$	LSB
Absolute accuracy	—	—	$\pm 8.0$	LSB

## 20.2.5 Flash Memory Characteristics

Table 20.9 shows the flash memory characteristics.

**Table 20.9 Flash Memory Characteristics**

— Preliminary —

Conditions:  $V_{CC} = 2.7\text{ V to }3.6\text{ V}$ ,  $AV_{CC} = 2.7\text{ V to }3.6\text{ V}$ ,  $V_{ref} = 2.7\text{ V to }AV_{CC}$ ,  $V_{SS} = AV_{SS} = 0\text{ V}$ ,  $V_{CC} = 3.0\text{ V to }3.6\text{ V}$  (program/erase operating voltage range),  $T_a = -20^\circ\text{C to }+75^\circ\text{C}$  (program/erase operating temperature range)

Item	Symbol	Min	Typ	Max	Unit	Test Conditions	
Programming time*1, *2, *4	$t_P$	—	10	200	ms/ 128 bytes		
Erase time*1, *3, *5	$t_E$	—	100	1200	ms/block		
Rewrite times	$N_{WEC}$	—	—	100	Times		
Programming	Wait time after SWE1 bit setting*1	$t_{sswe}$	1	1	—	$\mu\text{s}$	
	Wait time after PSU1 bit setting*1	$t_{spsu}$	50	50	—	$\mu\text{s}$	
	Wait time after P1 bit setting*1, *4	$t_{sp10}$	8	10	12	$\mu\text{s}$	
		$t_{sp30}$	28	30	32	$\mu\text{s}$	$1 \leq n \leq 6$
		$t_{sp200}$	198	200	202	$\mu\text{s}$	$7 \leq n \leq 1000$
	Wait time after P1 bit clearing*1	$t_{cp}$	5	5	—	$\mu\text{s}$	
	Wait time after PSU1 bit clearing*1	$t_{cpsu}$	5	5	—	$\mu\text{s}$	
	Wait time after PV1 bit setting*1	$t_{spv}$	4	4	—	$\mu\text{s}$	
	Wait time after H'FF dummy write*1	$t_{spvr}$	2	2	—	$\mu\text{s}$	
	Wait time after PV1 bit clearing*1	$t_{cpv}$	2	2	—	$\mu\text{s}$	
	Wait time after SWE1 bit clearing*1	$t_{cswe}$	100	100	—	$\mu\text{s}$	
	Maximum number of programming operations *1, *4	N1	—	—	6*4	Times	
		N2	—	—	994*4		
	Erasing	Wait time after SWE1 bit setting*1	$t_{sswe}$	1	1	—	$\mu\text{s}$
Wait time after ESU1 bit setting*1		$t_{sesu}$	100	100	—	$\mu\text{s}$	
Wait time after E1 bit setting*1, *5		$t_{se}$	10	10	100	ms	
Wait time after E1 bit clearing*1		$t_{ce}$	10	10	—	$\mu\text{s}$	
Wait time after ESU1 bit clearing*1		$t_{cesu}$	10	10	—	$\mu\text{s}$	
Wait time after EV1 bit setting*1		$t_{sev}$	20	20	—	$\mu\text{s}$	
Wait time after H'FF dummy write*1		$t_{sevr}$	2	2	—	$\mu\text{s}$	
Wait time after EV1 bit clearing*1		$t_{cev}$	4	4	—	$\mu\text{s}$	
Wait time after SWE1 bit clearing		$t_{cswe}$	100	100	—	$\mu\text{s}$	
Maximum number of erases*1, *5		N	—	—	100	Times	

Notes: \*1 Follow the program/erase algorithms when making the time settings.

\*2 Programming time per 128 bytes. (Indicates the total time during which the P1 bit is set in flash memory control register 1 (FLMCR1). Does not include the program-verify time.)

- \*3 Time to erase one block. (Indicates the time during which the E1 bit is set in FLMCR1. Does not include the erase-verify time.)
- \*4 Maximum programming time  

$$t_p(\text{max}) = \text{Wait time after P1 bit setting } (t_{sp}) \times \text{maximum number of writes (N)}$$

$$(t_{sp30} + t_{sp10}) \times 6 + (t_{sp200}) \times 994$$
- \*5 For the maximum erase time ( $t_E(\text{max})$ ), the following relationship applies between the wait time after E1 bit setting ( $t_{se}$ ) and the maximum number of erases (N):  

$$t_E(\text{max}) = \text{Wait time after E1 bit setting } (t_{se}) \times \text{maximum number of erases (N)}$$



## 20.3 Operational Timing

This section shows timing diagrams.

### 20.3.1 Clock Timing

Clock timing diagrams are shown below.

#### System Clock Timing

Figure 20.3 shows the system clock timing.

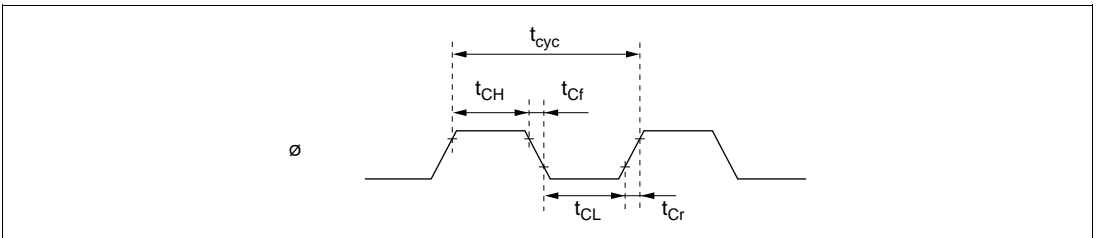


Figure 20.3 System Clock Timing

#### Oscillation Stabilization Timing

Figure 20.4 shows the oscillation stabilization timing.

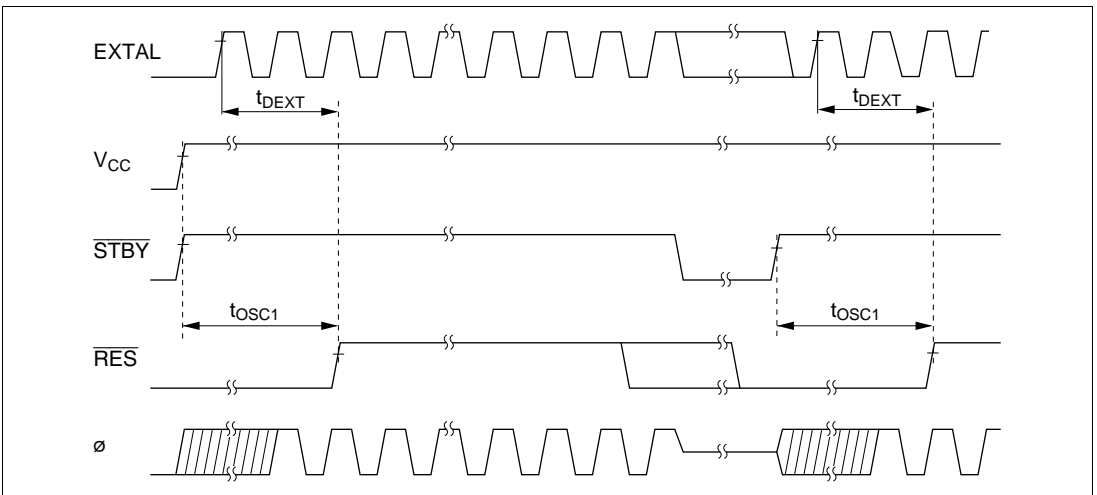


Figure 20.4 Oscillation Stabilization Timing

### 20.3.2 Control Signal Timing

Control signal timing diagrams are shown below.

#### Reset Input Timing

Figure 20.5 shows the reset input timing.

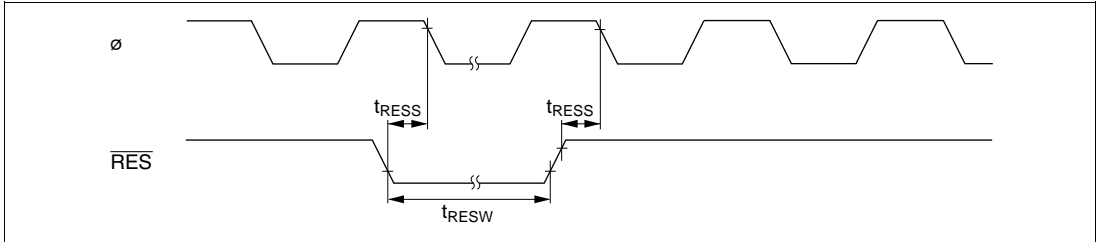


Figure 20.5 Reset Input Timing

#### Interrupt Input Timing

Figure 20.6 shows the timing of NMI and  $\overline{IRQ}$  interrupt input.

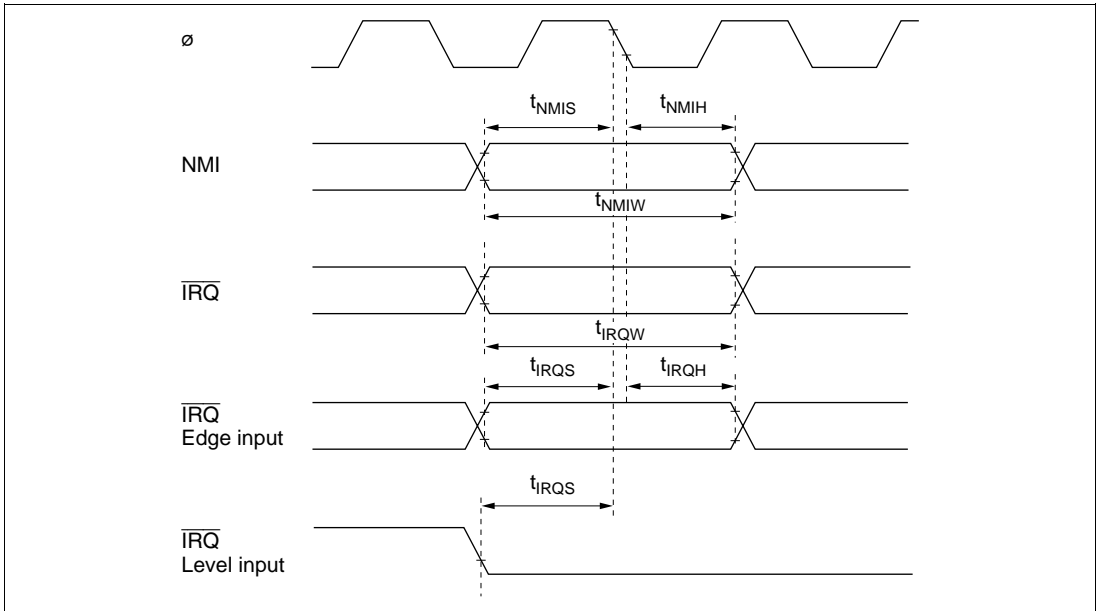


Figure 20.6 Interrupt Input Timing

### 20.3.3 Bus Timing

The following bus timing diagrams are shown here.

#### Basic Bus Timing: Two-State Access

Figure 20.7 shows the timing of external two-state access.

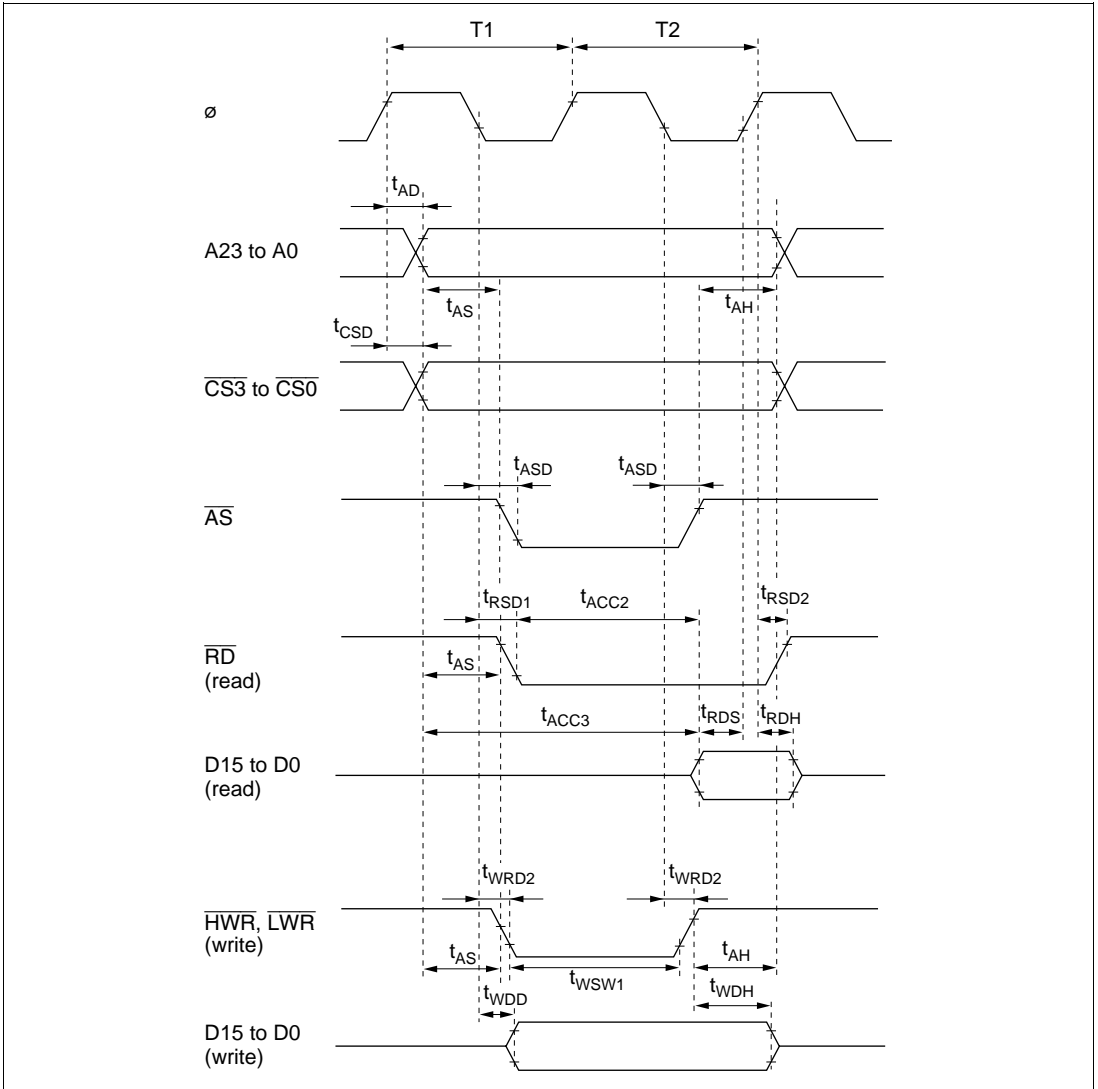
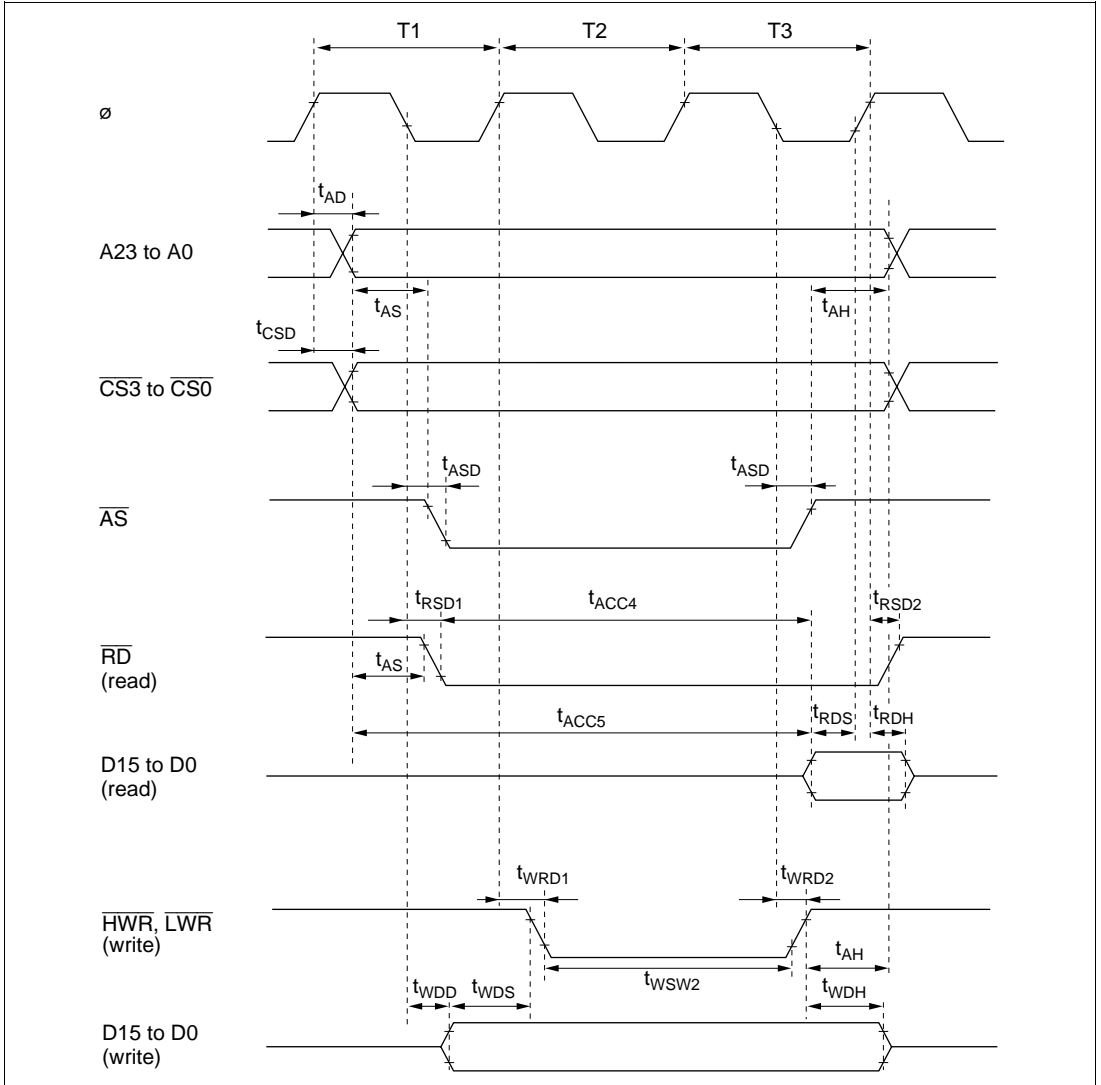


Figure 20.7 Basic Bus Timing (Two-State Access)

## Basic Bus Timing: Three-State Access

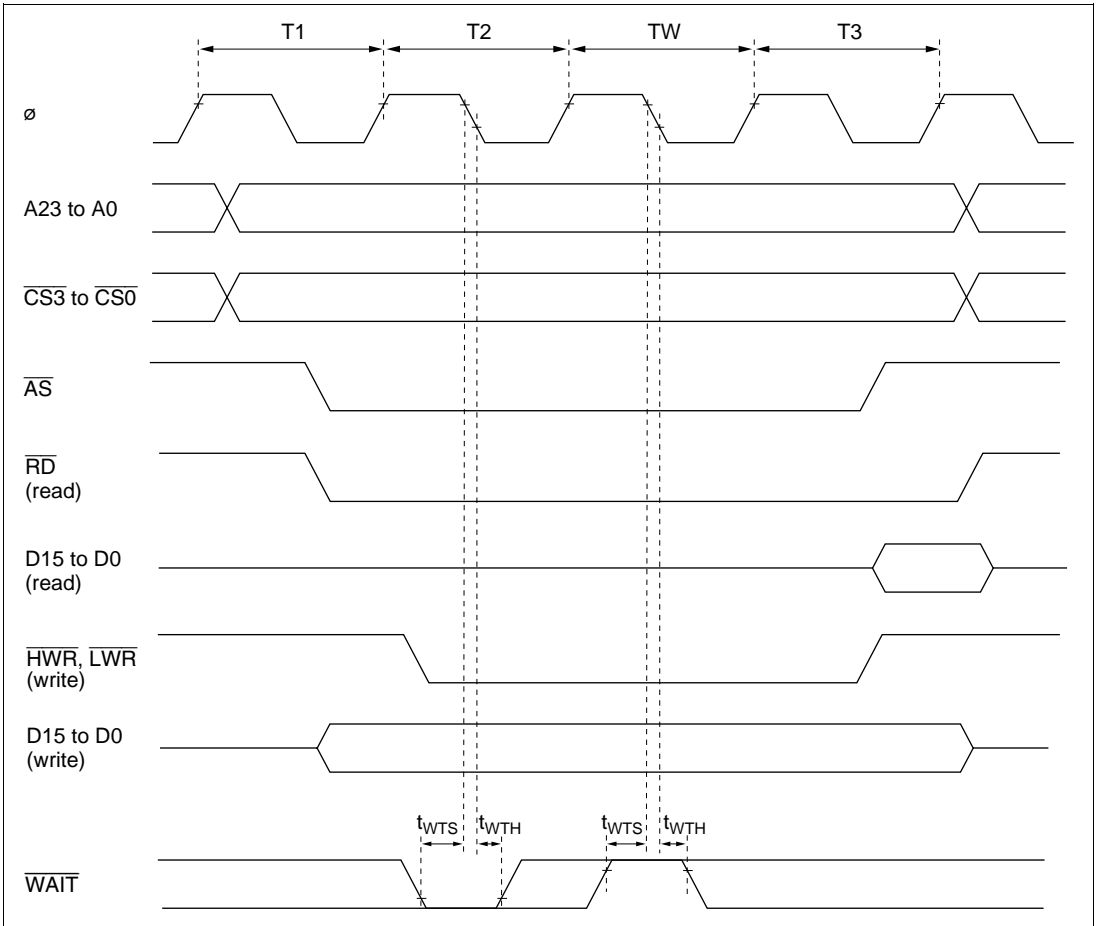
Figure 20.8 shows the timing of external three-state access.



**Figure 20.8 Basic Bus Timing (Three-State Access)**

## Basic Bus Timing: Three-State Access with One Wait

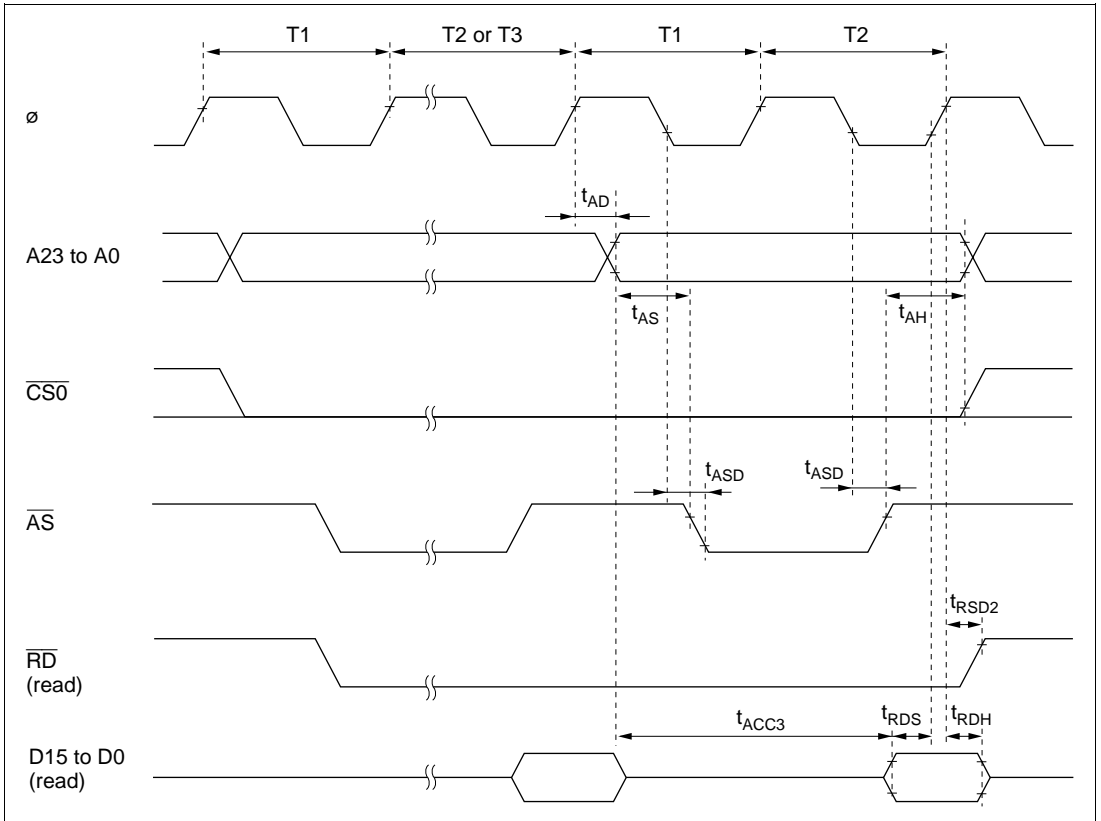
Figure 20.9 shows the timing of external three-state access with one wait inserted.



**Figure 20.9 Basic Bus Timing (Three-State Access with One Wait State)**

## Burst ROM Access Timing: Two-State

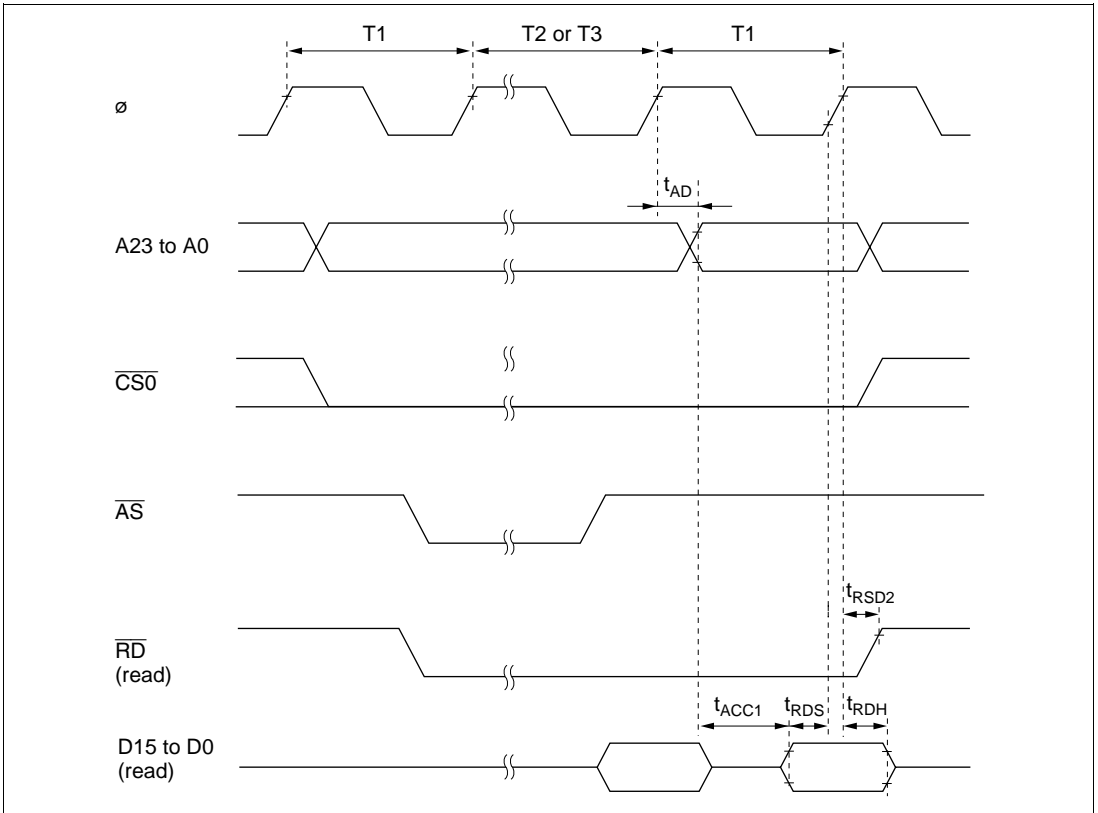
Figure 20.10 shows the timing of burst ROM two-state access.



**Figure 20.10 Burst ROM Access Timing (Two-State Access)**

## Burst ROM Access Timing: One-State

Figure 20.11 shows the timing of burst ROM one-state access.



**Figure 20.11 Burst ROM Access Timing (One-State Access)**

## External Bus Release Timing

Figure 20.12 shows the timing of external bus release.

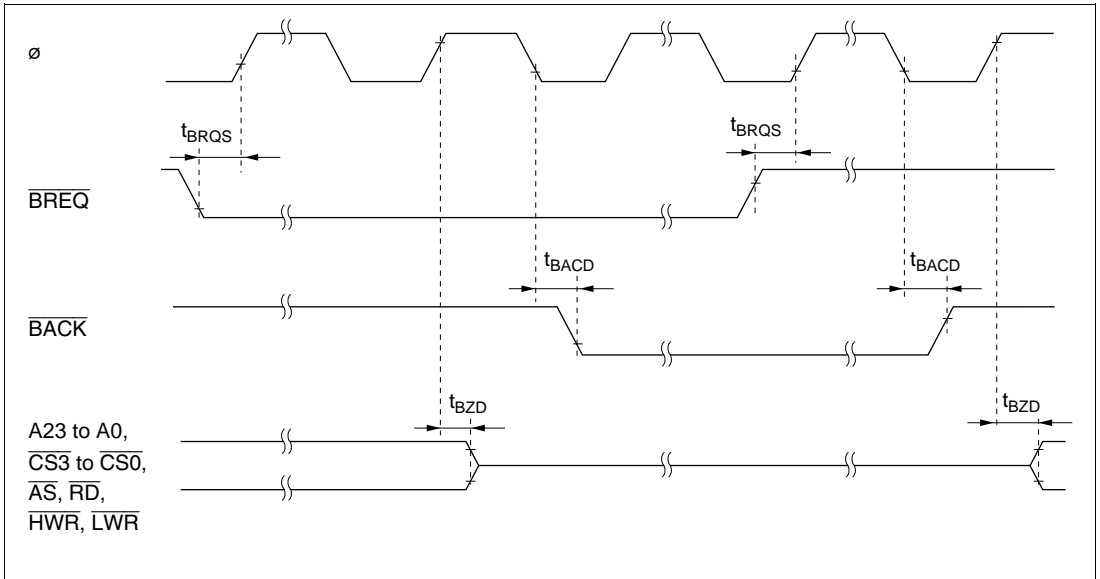


Figure 20.12 External Bus Release Timing

### 20.3.4 Timing of On-Chip Supporting Modules

Figures 20.13 to 20.19 show the timing of the on-chip supporting modules.

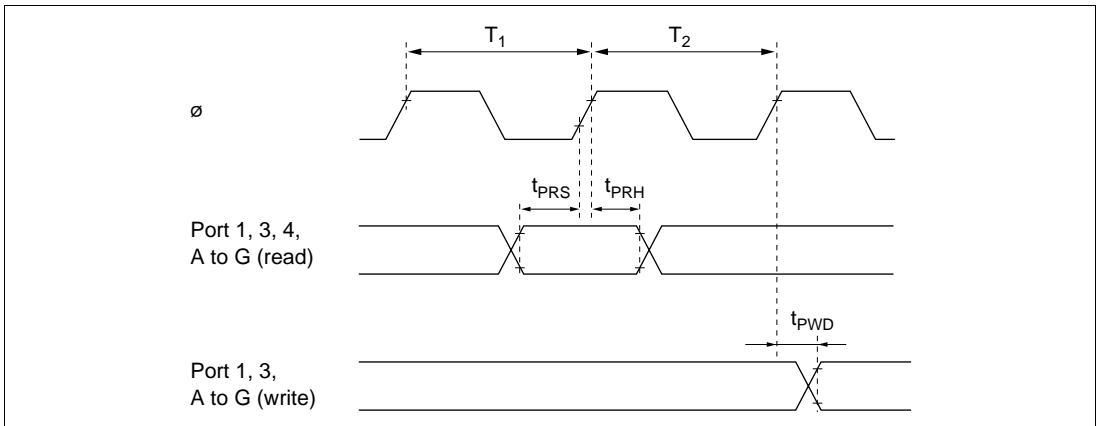
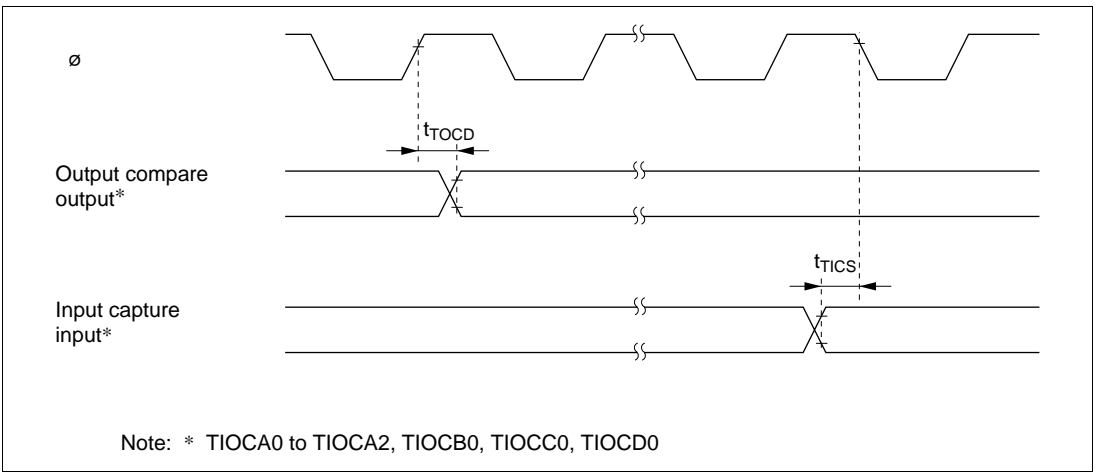
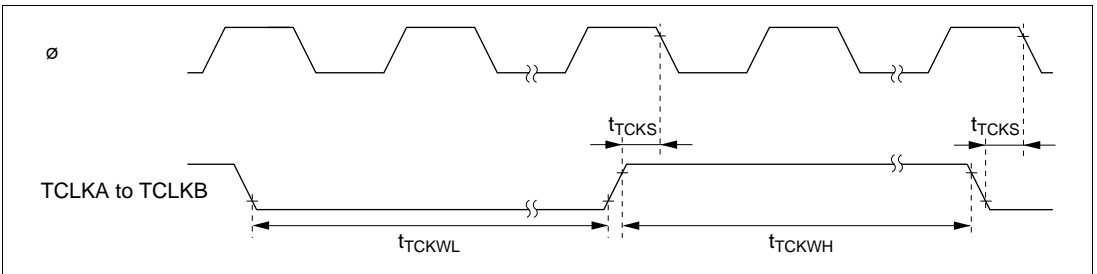


Figure 20.13 I/O Port Input/Output Timing

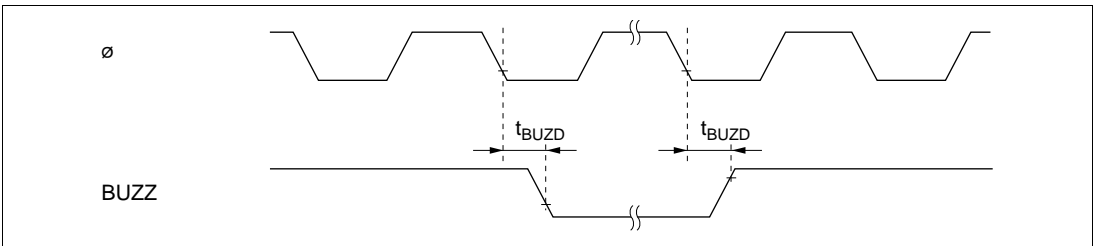




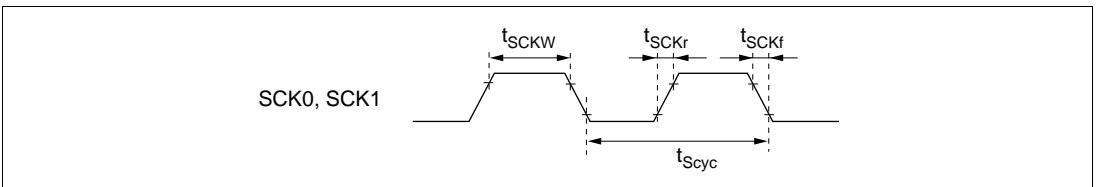
**Figure 20.14 TPU Input/Output Timing**



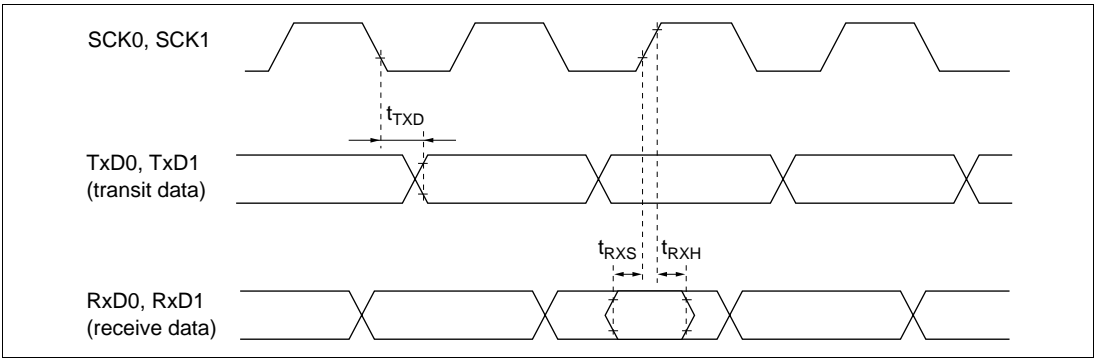
**Figure 20.15 TPU Clock Input Timing**



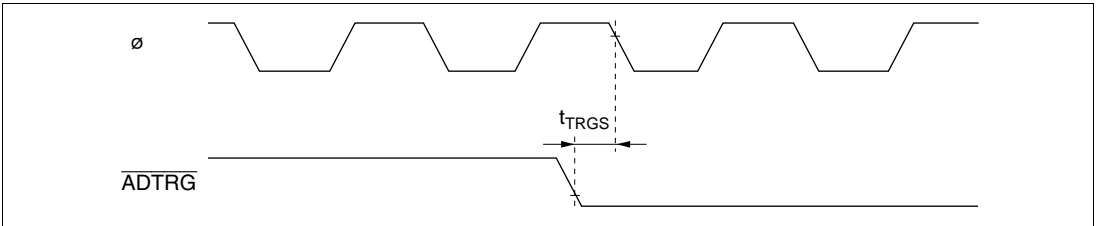
**Figure 20.16 WDT1 Output Timing**



**Figure 20.17 SCK Clock Input Timing**



**Figure 20.18 SCI Input/Output Timing (Clock Synchronous Mode)**



**Figure 20.19 A/D Converter External Trigger Input Timing**

# Appendix A Instruction Set

## A.1 Instruction List

### Operand Notation

Rd	General register (destination)* <sup>1</sup>
Rs	General register (source)* <sup>1</sup>
Rn	General register* <sup>1</sup>
ERn	General register (32-bit register)
MAC	Multiply-and-accumulate register (32-bit register)* <sup>2</sup>
(EAd)	Destination operand
(EAs)	Source operand
EXR	Extended control register
CCR	Condition-code register
N	N (negative) flag in CCR
Z	Z (zero) flag in CCR
V	V (overflow) flag in CCR
C	C (carry) flag in CCR
PC	Program counter
SP	Stack pointer
#IMM	Immediate data
disp	Displacement
+	Add
−	Subtract
×	Multiply
÷	Divide
∧	Logical AND
∨	Logical OR
⊕	Logical exclusive OR
→	Transfer from the operand on the left to the operand on the right, or transition from the state on the left to the state on the right
¬	Logical NOT (logical complement)
( ) < >	Contents of operand
:8/:16/:24/:32	8-, 16-, 24-, or 32-bit length

Notes: \*<sup>1</sup> General registers include 8-bit registers (R0H to R7H, R0L to R7L), 16-bit registers (R0 to R7, E0 to E7), and 32-bit registers (ER0 to ER7).

\*<sup>2</sup> The MAC register cannot be used in the LSI.

## Condition Code Notation

### Symbol

↓	Changes according to the result of instruction
*	Undetermined (no guaranteed value)
0	Always cleared to 0
1	Always set to 1
—	Not affected by execution of the instruction

Table A-1 Instruction Set

(1) Data Transfer Instructions

Mnemonic	Operand Size	Addressing Mode/ Instruction Length (Bytes)							Operation	Condition Code							No. of States*1
		#xx	@ERN	@(d,ERN)	@FRn/ERN+	@aa	@ (d,PC)	@aa		I	H	N	Z	V	C	Advanced	
MOV	B	2						#xx:8→Rd8	—	—	↑	↑	0	—	1		
	B	2						R8→Rd8	—	—	↑	↑	0	—	1		
	B	2						@ERS→Rd8	—	—	↑	↑	0	—	2		
	B	4						@(d:16,ERS)→Rd8	—	—	↑	↑	0	—	3		
	B	8						@(d:32,ERS)→Rd8	—	—	↑	↑	0	—	5		
	B	2						@ERS→Rd8,ERS32+1→ERS32	—	—	↑	↑	0	—	3		
	B						2	@aa:8→Rd8	—	—	↑	↑	0	—	2		
	B						4	@aa:16→Rd8	—	—	↑	↑	0	—	3		
	B						6	@aa:32→Rd8	—	—	↑	↑	0	—	4		
	B	2						R88→@ERd	—	—	↑	↑	0	—	2		
	B	4						R88→@(d:16,ERd)	—	—	↑	↑	0	—	3		
	B	8						R88→@(d:32,ERd)	—	—	↑	↑	0	—	5		
	B	2						ERd32:1→ERd32,R88→@ERd	—	—	↑	↑	0	—	3		
	B						2	R88→@aa:8	—	—	↑	↑	0	—	2		
	B						4	R88→@aa:16	—	—	↑	↑	0	—	3		
	B						6	R88→@aa:32	—	—	↑	↑	0	—	4		
	W	4						#xx:16→Rd16	—	—	↑	↑	0	—	2		
	W	2						Rs16→Rd16	—	—	↑	↑	0	—	1		
	W	2						@ERS→Rd16	—	—	↑	↑	0	—	2		



Mnemonic	Operand Size	Addressing Mode/ Instruction Length (Bytes)							Operation	Condition Code							No. of States <sup>ref</sup>	
		#xx	Rn	@ERn	@d,ERn	@-Rn/@ERn+	@aa	@d,PC		@aa	I	H	N	Z	V	C	Advanced	No. of States <sup>ref</sup>
MOV	L	4							ERS32→@ERd	—	—	↕	↕	0	—	4		
	L		6						ERS32→@d:16,ERd	—	—	↕	↕	0	—	5		
	L		10						ERS32→@d:32,ERd	—	—	↕	↕	0	—	7		
	L		4						ERd32-4→ERd32,ERS32→@ERd	—	—	↕	↕	0	—	5		
	L			6					ERS32→@aa:16	—	—	↕	↕	0	—	5		
	L			8					ERS32→@aa:32	—	—	↕	↕	0	—	6		
POP	W							2	@SP→Rn16,SP+2→SP	—	—	↕	↕	0	—	3		
	L							4	@SP→ERn32,SP+4→SP	—	—	↕	↕	0	—	5		
PUSH	W							2	SP-2→SP,Rn16→@SP	—	—	↕	↕	0	—	3		
	L							4	SP-4→SP,ERn32→@SP	—	—	↕	↕	0	—	5		
LDM	L							4	@SP→ERn32,SP+4→SP	—	—	—	—	—	—	7/9/11 [1]		
STM	L							4	(@SP→ERn32,SP+4→SP) Repeated for each register restored	—	—	—	—	—	—	7/9/11 [1]		
MOVFP									Repeated for each register saved								[2]	
MOVTP									Repeated for each register saved								[2]	

## (2) Arithmetic Instructions

Mnemonic	Operand Size	Addressing Mode/ Instruction Length (Bytes)						Operation	Condition Code							No. of States <sup>*1</sup>	
		#xx	Rn	@(ERn)	@(a,ERn)	@(a,ERn)/@FRn+	@aa		@(a,PC)	@aa	@aa	I	H	N	Z	V	C
ADD	B	2						Rd8+#xx:8→Rd8	—	↓	↓	↓	↓	↓	↓	1	
	B	2						Rd8+Rs8→Rd8	—	↓	↓	↓	↓	↓	↓	1	
	W	4						Rd16+#xx:16→Rd16	—	[3]	↓	↓	↓	↓	↓	2	
	W	2						Rd16+Rs16→Rd16	—	[3]	↓	↓	↓	↓	↓	1	
	L	6						ERd32+#xx:32→ERd32	—	[4]	↓	↓	↓	↓	↓	3	
ADDX	L	2						ERd32+ERs32→ERd32	—	[4]	↓	↓	↓	↓	↓	1	
	B	2						Rd8+#xx:8+C→Rd8	—	↓	↓	[5]	↓	↓	↓	1	
	B	2						Rd8+Rs8+C→Rd8	—	↓	↓	[5]	↓	↓	↓	1	
	L	2						ERd32+1→ERd32	—	—	—	—	—	—	—	1	
	L	2						ERd32+2→ERd32	—	—	—	—	—	—	—	1	
INC	L	2						ERd32+4→ERd32	—	—	—	—	—	—	—	1	
	B	2						Rd8+1→Rd8	—	—	↓	↓	↓	↓	↓	1	
	W	2						Rd16+1→Rd16	—	—	↓	↓	↓	↓	↓	1	
	W	2						Rd16+2→Rd16	—	—	↓	↓	↓	↓	↓	1	
	L	2						ERd32+1→ERd32	—	—	↓	↓	↓	↓	↓	1	
DAA	L	2						ERd32+2→ERd32	—	—	↓	↓	↓	↓	↓	1	
	B	2						Rd8 decimal adjust→Rd8	—	*	↓	↓	*	↓	↓	1	
	B	2						Rd8-Rs8→Rd8	—	↓	↓	↓	↓	↓	↓	1	
	W	4						Rd16+#xx:16→Rd16	—	[3]	↓	↓	↓	↓	↓	2	





Mnemonic	Operand Size	Addressing Mode/ Instruction Length (Bytes)						Operation	Condition Code							No. of States <sup>*1</sup>		
		#xx	Rn	@ERN	@d,ERN	@-ERN/@ERN+	@aa		@d,PC	@aa	I	H	N	Z	V	C	Advanced	12
DIVXU	B	2						Rd16+Rs8→Rd16 (RdH: remainder, RdL: quotient) (unsigned division)	—	—	[6]	[7]	—	—	—	—	12	
	W	2						ERd32+Rs16→ERd32 (Ed: remainder, Rd: quotient) (unsigned division)	—	—	[6]	[7]	—	—	—	—	20	
DIVXS	B	4						Rd16+Rs8→Rd16 (RdH: remainder, RdL: quotient) (signed division)	—	—	[8]	[7]	—	—	—	—	13	
	W	4						ERd32+Rs16→ERd32 (Ed: remainder, Rd: quotient) (signed division)	—	—	[8]	[7]	—	—	—	—	21	
CMP	B	2						Rd8-#xx:8	—	↑	↓	↑	↓	↑	↓	↑	1	
	B	2						Rd8+Rs8	—	↑	↓	↑	↓	↑	↓	↑	1	
	W	4						Rd16-#xx:16	—	[3]	↓	↑	↓	↑	↓	↑	2	
	W	2						Rd16-Rs16	—	[3]	↓	↑	↓	↑	↓	↑	1	
	L	6						ERd32-#xx:32	—	[4]	↓	↑	↓	↑	↓	↑	3	
	L	2						ERd32-ERs32	—	[4]	↓	↑	↓	↑	↓	↑	1	
NEG	B	2						0-Rd8→Rd8	—	↑	↓	↑	↓	↑	↓	↑	1	
	W	2						0-Rd16→Rd16	—	↑	↓	↑	↓	↑	↓	↑	1	
	L	2						0-ERd32→ERd32	—	↑	↓	↑	↓	↑	↓	↑	1	
EXTU	W	2						0→(<bit 15 to 8> of Rd16)	—	—	0	↑	0	—	—	—	1	
	L	2						0→(<bit 31 to 16> of ERd32)	—	—	0	↑	0	—	—	—	1	

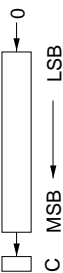
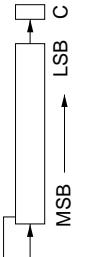
Mnemonic	Operand Size	Addressing Mode/ Instruction Length (Bytes)							Operation	Condition Code							No. of States <sup>*1</sup> Advanced
		#xx	ERn	@ERn	@(d,ERn)	@-ERn/@ERn+	@aa	@(d,PC)		@aa	I	H	N	Z	V	C	
EXTS	W	2							(<bit 7> of Rd16)→	—	—	↕	↕	0	—	1	
	L	2							(<bit 15 to 8> of Rd16)	—	—	↕	↕	0	—	1	
TAS	B	4							@ERd-0→CCR set, (1)→ (<bit 31 to 16> of ERd32)	—	—	↕	↕	0	—	4	
MAC	Cannot be used in the LSI																
CLRMAC																	
LDMAC																	
STMAC																	
	[2]																

### (3) Logical Instructions

Mnemonic	Operand Size	Addressing Mode/ Instruction Length (Bytes)							Operation	Condition Code							No. of States*1
		#xx	@ERN	@(d,ERn)	@-Rn/@FRn+	@aa	@ (d,PC)	@ @aa		I	H	N	Z	V	C	Advanced	
AND	B 2								Rd8^#xx:8→Rd8	-	-	↓	↓	0	-	1	
	B 2								Rd8^Rs8→Rd8	-	-	↓	↓	0	-	1	
	W 4								Rd16^#xx:16→Rd16	-	-	↓	↓	0	-	2	
	W 2								Rd16^Rs16→Rd16	-	-	↓	↓	0	-	1	
	L 6								ERd32^#xx:32→ERd32	-	-	↓	↓	0	-	3	
	L 4								ERd32^ERS32→ERd32	-	-	↓	↓	0	-	2	
OR	B 2								Rd8^#xx:8→Rd8	-	-	↓	↓	0	-	1	
	B 2								Rd8^Rs8→Rd8	-	-	↓	↓	0	-	1	
	W 4								Rd16^#xx:16→Rd16	-	-	↓	↓	0	-	2	
	W 2								Rd16^Rs16→Rd16	-	-	↓	↓	0	-	1	
	L 6								ERd32^#xx:32→ERd32	-	-	↓	↓	0	-	3	
	L 4								ERd32^ERS32→ERd32	-	-	↓	↓	0	-	2	
XOR	B 2								Rd8⊕#xx:8→Rd8	-	-	↓	↓	0	-	1	
	B 2								Rd8⊕Rs8→Rd8	-	-	↓	↓	0	-	1	
	W 4								Rd16⊕#xx:16→Rd16	-	-	↓	↓	0	-	2	
	W 2								Rd16⊕Rs16→Rd16	-	-	↓	↓	0	-	1	
	L 6								ERd32⊕#xx:32→ERd32	-	-	↓	↓	0	-	3	
	L 4								ERd32⊕ERS32→ERd32	-	-	↓	↓	0	-	2	
NOT	B 2								¬Rd8→Rd8	-	-	↓	↓	0	-	2	
	B 2								¬Rd8→Rd8	-	-	↓	↓	0	-	1	
	W 4								¬Rd16→Rd16	-	-	↓	↓	0	-	1	
	W 2								¬Rd16→Rd16	-	-	↓	↓	0	-	1	
	L 6								¬ERd32→ERd32	-	-	↓	↓	0	-	3	
	L 4								¬ERd32→ERd32	-	-	↓	↓	0	-	2	

#### (4) Shift Instructions

Mnemonic	Operand Size	Addressing Mode/ Instruction Length (Bytes)						Operation	Condition Code							No. of States <sup>*1</sup>				
		#xx	@ERN	@(d,ERn)	@-FRn/@ERn+	@aa	@(d,PC)		@aa	I	H	N	Z	V	C	Advanced				
SHAL	SHAL.B Rd	B	2												↕	↕	↕	↕	1	
	SHAL.B #2,Rd	B	2												↕	↕	↕	↕	1	
	SHAL.W Rd	W	2												↕	↕	↕	↕	1	
	SHAL.W #2,Rd	W	2												↕	↕	↕	↕	1	
	SHAL.L ERd	L	2												↕	↕	↕	↕	1	
	SHAL.L #2,ERd	L	2												↕	↕	↕	↕	1	
SHAR	SHAR.B Rd	B	2												↕	↕	0	↕	1	
	SHAR.B #2,Rd	B	2												↕	↕	0	↕	1	
	SHAR.W Rd	W	2												↕	↕	0	↕	1	
	SHAR.W #2,Rd	W	2												↕	↕	0	↕	1	
	SHAR.L ERd	L	2												↕	↕	0	↕	1	
	SHAR.L #2,ERd	L	2												↕	↕	0	↕	1	
SHLL	SHLL.B Rd	B	2												↕	↕	0	↕	1	
	SHLL.B #2,Rd	B	2												↕	↕	0	↕	1	
	SHLL.W Rd	W	2												↕	↕	0	↕	1	
	SHLL.W #2,Rd	W	2												↕	↕	0	↕	1	
	SHLL.L ERd	L	2												↕	↕	0	↕	1	
	SHLL.L #2,ERd	L	2												↕	↕	0	↕	1	



Mnemonic	Operand Size	Addressing Mode/ Instruction Length (Bytes)							Operation	Condition Code							No. of States <sup>※1</sup>	
		#xx	Rn	@ERN	@(d,ERn)	@-FRn/@ERn+	@aa	@(d,PC)		@aa	I	H	N	Z	V	C	Advanced	
SHLR	SHLR.B Rd	B	2										0	0	0	0	1	1
	SHLR.B #2,Rd	B	2										0	0	0	0	1	1
	SHLR.W Rd	W	2										0	0	0	0	1	1
	SHLR.W #2,Rd	W	2										0	0	0	0	1	1
	SHLR.L ERd	L	2										0	0	0	0	1	1
	SHLR.L #2,ERd	L	2										0	0	0	0	1	1
ROTXL	ROTXL.B Rd	B	2										0	0	0	0	1	1
	ROTXL.B #2,Rd	B	2										0	0	0	0	1	1
	ROTXL.W Rd	W	2										0	0	0	0	1	1
	ROTXL.W #2,Rd	W	2										0	0	0	0	1	1
	ROTXL.L ERd	L	2										0	0	0	0	1	1
	ROTXL.L #2,ERd	L	2										0	0	0	0	1	1
ROTXR	ROTXR.B Rd	B	2										0	0	0	0	1	1
	ROTXR.B #2,Rd	B	2										0	0	0	0	1	1
	ROTXR.W Rd	W	2										0	0	0	0	1	1
	ROTXR.W #2,Rd	W	2										0	0	0	0	1	1
	ROTXR.L ERd	L	2										0	0	0	0	1	1
	ROTXR.L #2,ERd	L	2										0	0	0	0	1	1

Mnemonic	Operand Size	Addressing Mode/ Instruction Length (Bytes)						Operation	Condition Code							No. of States <sup>*)1</sup> Advanced
		#xx	Rn	@ERn	@(d,ERn)	@-ERn/@ERn+	@aa		@(d,PC)	@aa	I	H	N	Z	V	
ROTL	B	2							—	—	—	—	0	—	—	1
	B	2							—	—	—	—	0	—	—	1
	W	2							—	—	—	—	0	—	—	1
	W	2							—	—	—	—	0	—	—	1
	L	2							—	—	—	—	0	—	—	1
ROTR	B	2						—	—	—	—	0	—	—	1	
	B	2						—	—	—	—	0	—	—	1	
	W	2						—	—	—	—	0	—	—	1	
	W	2						—	—	—	—	0	—	—	1	
	L	2						—	—	—	—	0	—	—	1	

(5) Bit-Manipulation Instructions

Mnemonic	Operand Size	Addressing Mode/ Instruction Length (Bytes)						Operation	Condition Code					No. of States*1 Advanced	
		#xx	Rn	@(d,ERn)	@(d,ERn)/@ERn+	@aa	@(d,PC)		I	H	N	Z	V		C
BSET	BSET #xx:3,Rd	B	2					(#xx:3 of Rd8)←-1	-	-	-	-	-	-	1
	BSET #xx:3,@ERd	B	4					(#xx:3 of @ERd)←-1	-	-	-	-	-	-	4
	BSET #xx:3,@aa:8	B		4				(#xx:3 of @aa:8)←-1	-	-	-	-	-	-	4
	BSET #xx:3,@aa:16	B		6				(#xx:3 of @aa:16)←-1	-	-	-	-	-	-	5
	BSET #xx:3,@aa:32	B		8				(#xx:3 of @aa:32)←-1	-	-	-	-	-	-	6
	BSET Rn,Rd	B	2					(Rn8 of Rd8)←-1	-	-	-	-	-	-	1
	BSET Rn,@ERd	B	4					(Rn8 of @ERd)←-1	-	-	-	-	-	-	4
	BSET Rn,@aa:8	B		4				(Rn8 of @aa:8)←-1	-	-	-	-	-	-	4
BCLR	BSET Rn,@aa:16	B		6				(Rn8 of @aa:16)←-1	-	-	-	-	-	-	5
	BSET Rn,@aa:32	B		8				(Rn8 of @aa:32)←-1	-	-	-	-	-	-	6
	BCLR #xx:3,Rd	B	2					(#xx:3 of Rd8)←-0	-	-	-	-	-	-	1
	BCLR #xx:3,@ERd	B	4					(#xx:3 of @ERd)←-0	-	-	-	-	-	-	4
	BCLR #xx:3,@aa:8	B		4				(#xx:3 of @aa:8)←-0	-	-	-	-	-	-	4
	BCLR #xx:3,@aa:16	B		6				(#xx:3 of @aa:16)←-0	-	-	-	-	-	-	5
	BCLR #xx:3,@aa:32	B		8				(#xx:3 of @aa:32)←-0	-	-	-	-	-	-	6
	BCLR Rn,Rd	B	2					(Rn8 of Rd8)←-0	-	-	-	-	-	-	1
BCLR Rn,@ERd	BCLR Rn,@ERd	B	4					(Rn8 of @ERd)←-0	-	-	-	-	-	-	4
	BCLR Rn,@aa:8	B		4				(Rn8 of @aa:8)←-0	-	-	-	-	-	-	4
	BCLR Rn,@aa:16	B		6				(Rn8 of @aa:16)←-0	-	-	-	-	-	-	5
	BCLR Rn,@aa:32	B		8				(Rn8 of @aa:32)←-0	-	-	-	-	-	-	6



Mnemonic	Operand Size	Addressing Mode/ Instruction Length (Bytes)						Operation	Condition Code						No. of States*1			
		#xx	Rn	@ERn	@d,ERn	@-ERn/@ERn+	@aa		@d,PC	@aa	I	H	N	Z		V	C	Advanced
BCLR	B					8		(Rn8 of @aa:32) ← 0	—	—	—	—	—	—	—	6		
BNOT	B	2						(#xx:3 of Rd8) ← [¬ (#xx:3 of Rd8)]	—	—	—	—	—	—	—	1		
	B	4						(#xx:3 of @ERd) ← [¬ (#xx:3 of @ERd)]	—	—	—	—	—	—	—	4		
	B		4					(#xx:3 of @aa:8) ← [¬ (#xx:3 of @aa:8)]	—	—	—	—	—	—	—	4		
	B			6				(#xx:3 of @aa:16) ← [¬ (#xx:3 of @aa:16)]	—	—	—	—	—	—	—	5		
BNOT	B					8		(#xx:3 of @aa:32) ← [¬ (#xx:3 of @aa:32)]	—	—	—	—	—	—	—	6		
	B	2						(Rn8 of Rd8) ← [¬ (Rn8 of Rd8)]	—	—	—	—	—	—	—	1		
	B		4					(Rn8 of @ERd) ← [¬ (Rn8 of @ERd)]	—	—	—	—	—	—	—	4		
	B					4		(Rn8 of @aa:8) ← [¬ (Rn8 of @aa:8)]	—	—	—	—	—	—	—	4		
	B					6		(Rn8 of @aa:16) ← [¬ (Rn8 of @aa:16)]	—	—	—	—	—	—	—	5		
	B					8		(Rn8 of @aa:32) ← [¬ (Rn8 of @aa:32)]	—	—	—	—	—	—	—	6		
BTST	B	2						¬ (#xx:3 of Rd8) → Z	—	—	—	↑	—	—	—	1		
	B		4					¬ (#xx:3 of @ERd) → Z	—	—	—	↑	—	—	—	3		
	B					4		¬ (#xx:3 of @aa:8) → Z	—	—	—	↑	—	—	—	3		
	B					6		¬ (#xx:3 of @aa:16) → Z	—	—	—	↑	—	—	—	4		



Mnemonic	Operand Size	Addressing Mode/ Instruction Length (Bytes)						Operation	Condition Code					No. of States <sup>8),1</sup> Advanced			
		#xx	Rn	@ERn	@d,ERn	@-ERn/@ERn+	@aa		@d,P,C	@aa	I	H	N		Z	V	C
BST	B						6	C→(#xx:3 of @aa:16)	—	—	—	—	—	—	5		
	B						8	C→(#xx:3 of @aa:32)	—	—	—	—	—	—	6		
BIST	B	2						¬ C→(#xx:3 of Rd8)	—	—	—	—	—	—	1		
	B	4						¬ C→(#xx:3 of @ERd)	—	—	—	—	—	—	4		
	B						4	¬ C→(#xx:3 of @aa:8)	—	—	—	—	—	—	4		
	B						6	¬ C→(#xx:3 of @aa:16)	—	—	—	—	—	—	5		
	B						8	¬ C→(#xx:3 of @aa:32)	—	—	—	—	—	—	6		
	B	2						C^(#xx:3 of Rd8)→C	—	—	—	—	—	↑	1		
BAND	B	4						C^(#xx:3 of @ERd)→C	—	—	—	—	—	↑	3		
	B						4	C^(#xx:3 of @aa:8)→C	—	—	—	—	—	↑	3		
	B						6	C^(#xx:3 of @aa:16)→C	—	—	—	—	—	↑	4		
	B						8	C^(#xx:3 of @aa:32)→C	—	—	—	—	—	↑	5		
	B	2						C^(¬ (#xx:3 of Rd8))→C	—	—	—	—	—	↑	1		
	B	4						C^(¬ (#xx:3 of @ERd))→C	—	—	—	—	—	↑	3		
BIAND	B						4	C^(¬ (#xx:3 of @aa:8))→C	—	—	—	—	—	↑	3		
	B						6	C^(¬ (#xx:3 of @aa:16))→C	—	—	—	—	—	↑	4		
	B						8	C^(¬ (#xx:3 of @aa:32))→C	—	—	—	—	—	↑	5		
	B	2						Cv(#xx:3 of Rd8)→C	—	—	—	—	—	↑	1		
	B	4						Cv(#xx:3 of @ERd)→C	—	—	—	—	—	↑	3		
	B								—	—	—	—	—	—			



### (6) Branch Instructions

Mnemonic	Operand Size	Addressing Mode/ Instruction Length (Bytes)							Operation	Condition Code							No. of States*1
		#xx	Rn	@ERn	@(d,ERn)	@-ERn/@ERn+	@aa	@(d,PC)		@aa	I	H	N	Z	V	C	
Bcc	—							2		if condition is true then PC←PC+d else next;	—	—	—	—	—	2	
BRA d:8(BT d:8)	—							4			Always	—	—	—	—	3	
BRA d:16(BT d:16)	—							2			Never	—	—	—	—	2	
BRN d:8(BF d:8)	—							4			C∧Z=0	—	—	—	—	3	
BRN d:16(BF d:16)	—							2			C∧Z=1	—	—	—	—	2	
BHI d:8	—							4			C=0	—	—	—	—	3	
BHI d:16	—							2			C=0	—	—	—	—	2	
BLS d:8	—							4			C=1	—	—	—	—	3	
BLS d:16	—							2			C=1	—	—	—	—	2	
BCC d:8(BHS d:8)	—							4			Z=0	—	—	—	—	3	
BCC d:16(BHS d:16)	—							2			Z=0	—	—	—	—	2	
BCS d:8(BLO d:8)	—							4			Z=1	—	—	—	—	3	
BCS d:16(BLO d:16)	—							2			Z=1	—	—	—	—	2	
BNE d:8	—							4			V=0	—	—	—	—	3	
BNE d:16	—							2			V=0	—	—	—	—	2	
BEQ d:8	—							4				—	—	—	—	3	
BEQ d:16	—							2				—	—	—	—	2	
BVC d:8	—							4				—	—	—	—	3	
BVC d:16	—							2				—	—	—	—	2	

Mnemonic	Operand Size	Addressing Mode/ Instruction Length (Bytes)							Operation	Condition Code					No. of States*1	
		#xx	$\overline{Rn}$	@ERN	@(d,ERN)	@-FRn/@ERN+	@aa	@(d,PC)		@aa	I	H	N	Z		V
Bcc	BVS d:8	—					2			V=1	—	—	—	—	—	2
	BVS d:16	—					4				—	—	—	—	—	3
	BPL d:8	—					2			N=0	—	—	—	—	—	2
	BPL d:16	—					4				—	—	—	—	—	3
	BMI d:8	—					2			N=1	—	—	—	—	—	2
	BMI d:16	—					4				—	—	—	—	—	3
	BGE d:8	—					2			N $\oplus$ V=0	—	—	—	—	—	2
	BGE d:16	—					4				—	—	—	—	—	3
	BLT d:8	—					2			N $\oplus$ V=1	—	—	—	—	—	2
	BLT d:16	—					4				—	—	—	—	—	3
	BGT d:8	—					2			Z $\vee$ (N $\oplus$ V)=0	—	—	—	—	—	2
	BGT d:16	—					4				—	—	—	—	—	3
	BLE d:8	—					2			Z $\vee$ (N $\oplus$ V)=1	—	—	—	—	—	2
	BLE d:16	—					4				—	—	—	—	—	3

Mnemonic	Operand Size	Addressing Mode/ Instruction Length (Bytes)							Operation	Condition Code						No. of States*1
		#xx	Rn	@ERn	@(d,ERn)	@-ERn/@ERn+	@aa	@(d,PC)		@@aa	I	H	N	Z	V	
JMP	—	—	2	—	—	—	—	—	PC←ERn	—	—	—	—	—	—	2
	—	—	—	4	—	—	—	—	PC←aa:24	—	—	—	—	—	—	3
	—	—	—	—	—	2	—	—	PC←@aa:8	—	—	—	—	—	—	5
BSR	—	—	—	—	2	—	—	—	PC→@-SP,PC←PC+d:8	—	—	—	—	—	—	4
	—	—	—	—	4	—	—	—	PC→@-SP,PC←PC+d:16	—	—	—	—	—	—	5
JSR	—	—	2	—	—	—	—	—	PC→@-SP,PC←ERn	—	—	—	—	—	—	4
	—	—	—	—	4	—	—	—	PC→@-SP,PC←aa:24	—	—	—	—	—	—	5
	—	—	—	—	—	2	—	—	PC→@-SP,PC←@aa:8	—	—	—	—	—	—	6
RTS	—	—	—	—	—	—	—	—	PC←@SP+	—	—	—	—	—	—	5

(7) System Control Instructions

Mnemonic	Operand Size	Addressing Mode/ Instruction Length (Bytes)							Operation	Condition Code					No. of States*1	
		#xx	Rn	@ERN	@(d,ERN)	@ERN@ERN+	@aa	@(d,PC)		@aa	I	H	N	Z		V
TRAPA									PC→@-SP,CCR→@-SP, EXR→@-SP,<vector>→PC	1	—	—	—	—	—	8 [9]
RTE									EXR←@SP+,CCR←@SP+, PC←@SP+	↕	↕	↕	↕	↕	5 [9]	
SLEEP									Transition to power-down state	—	—	—	—	—	—	2
LDC	LDC #xx:8,CCR	B	2						#xx:8→CCR	↕	↕	↕	↕	↕	↕	1
	LDC #xx:8,EXR	B	4						#xx:8→EXR	—	—	—	—	—	—	2
	LDC Rs,CCR	B	2						Rs8→CCR	↕	↕	↕	↕	↕	↕	1
	LDC Rs,EXR	B	2						Rs8→EXR	—	—	—	—	—	—	1
	LDC @ERs,CCR	W		4					@ERs→CCR	↕	↕	↕	↕	↕	↕	3
	LDC @ERs,EXR	W		4					@ERs→EXR	—	—	—	—	—	—	3
	LDC @(d:16,ERs),CCR	W		6					@(d:16,ERs)→CCR	↕	↕	↕	↕	↕	↕	4
	LDC @(d:16,ERs),EXR	W		6					@(d:16,ERs)→EXR	—	—	—	—	—	—	4
	LDC @(d:32,ERs),CCR	W		10					@(d:32,ERs)→CCR	↕	↕	↕	↕	↕	↕	6
	LDC @(d:32,ERs),EXR	W		10					@(d:32,ERs)→EXR	—	—	—	—	—	—	6
LDC @ERs+,CCR	W			4				@ERs→CCR,ERs32+2→ERs32	↕	↕	↕	↕	↕	↕	4	
LDC @ERs+,EXR	W			4				@ERs→EXR,ERs32+2→ERs32	—	—	—	—	—	—	4	
LDC @aa:16,CCR	W			6				@aa:16→CCR	↕	↕	↕	↕	↕	↕	4	
LDC @aa:16,EXR	W			6				@aa:16→EXR	—	—	—	—	—	—	4	
LDC @aa:32,CCR	W			8				@aa:32→CCR	↕	↕	↕	↕	↕	↕	5	
LDC @aa:32,EXR	W			8				@aa:32→EXR	—	—	—	—	—	—	5	



Mnemonic	Operand Size	Addressing Mode/ Instruction Length (Bytes)						Operation	Condition Code					No. of States*1 Advanced	
		#xx	F <sub>1</sub>	@ (d,ERn)	@ -ERn/@ ERn+	@ aa	@ (d,P) @ aa		I	H	N	Z	V		C
STC	STC CCR,Rd	B	2					CCR→Rd8	—	—	—	—	—	1	
	STC EXR,Rd	B	2					EXR→Rd8	—	—	—	—	—	1	
	STC CCR,@ERd	W		4				CCR→@ERd	—	—	—	—	—	3	
	STC EXR,@ERd	W		4				EXR→@ERd	—	—	—	—	—	3	
	STC CCR,@(d:16,ERd)	W		6				CCR→@(d:16,ERd)	—	—	—	—	—	4	
	STC EXR,@(d:16,ERd)	W		6				EXR→@(d:16,ERd)	—	—	—	—	—	4	
	STC CCR,@(d:32,ERd)	W		10				CCR→@(d:32,ERd)	—	—	—	—	—	6	
	STC EXR,@(d:32,ERd)	W		10				EXR→@(d:32,ERd)	—	—	—	—	—	6	
	STC CCR,@-ERd	W		4				ERd32-2→ERd32,CCR→@ERd	—	—	—	—	—	4	
	STC EXR,@-ERd	W		4				ERd32-2→ERd32,EXR→@ERd	—	—	—	—	—	4	
ANDC	STC CCR,@aa:16	W				6		CCR→@aa:16	—	—	—	—	—	4	
	STC EXR,@aa:16	W				6		EXR→@aa:16	—	—	—	—	—	4	
	STC CCR,@aa:32	W				8		CCR→@aa:32	—	—	—	—	—	5	
	STC EXR,@aa:32	W				8		EXR→@aa:32	—	—	—	—	—	5	
	ANDC #xx:8,CCR	B	2					CCR^#xx:8→CCR	↑	↑	↑	↑	1		
	ANDC #xx:8,EXR	B	4					EXR^#xx:8→EXR	—	—	—	—	—	2	
	ORC	ORC #xx:8,CCR	B	2					CCR∨#xx:8→CCR	↑	↑	↑	↑	1	
		ORC #xx:8,EXR	B	4					EXR∨#xx:8→EXR	—	—	—	—	—	2
	XORC	XORC #xx:8,CCR	B	2					CCR⊕#xx:8→CCR	↑	↑	↑	↑	1	
		XORC #xx:8,EXR	B	4					EXR⊕#xx:8→EXR	—	—	—	—	—	2
NOP	NOP	—						PC←PC+2	—	—	—	—	—	1	

## (8) Block Transfer Instructions

Mnemonic	Operand Size	Addressing Mode/ Instruction Length (Bytes)							Operation	Condition Code							No. of States*1	
		#xx	FR	@FRn	@(d,FRn)	@-FRn/@FRn+	@aa	@(d,PC)		@aa	I	H	N	Z	V	C	Advanced	
EEPMOV	—								4	if R4L=0 Repeat @ER5→@ER6 ER5+1→ER5 ER6+1→ER6 R4L-1→R4L Until R4L=0 else next;	—	—	—	—	—	—	4+2n *3	
EEPMOV.W	—								4	if R4≠0 Repeat @ER5→@ER6 ER5+1→ER5 ER6+1→ER6 R4-1→R4 Until R4=0 else next;	—	—	—	—	—	—	4+2n *3	

Notes: \*1 The number of states is the number of states required for execution when the instruction and its operands are located in on-chip memory.

\*2 Only register ER0, ER1, ER4, or ER5 should be used when using the TAS instruction.

\*3 n is the initial value of R4L or R4.

- [1] Seven states for saving or restoring two registers, nine states for three registers, or eleven states for four registers.
- [2] Cannot be used in the LSI.
- [3] Set to 1 when a carry or borrow occurs at bit 11; otherwise cleared to 0.
- [4] Set to 1 when a carry or borrow occurs at bit 27; otherwise cleared to 0.
- [5] Retains its previous value when the result is zero; otherwise cleared to 0.
- [6] Set to 1 when the divisor is negative; otherwise cleared to 0.
- [7] Set to 1 when the divisor is zero; otherwise cleared to 0.
- [8] Set to 1 when the quotient is negative; otherwise cleared to 0.
- [9] One additional state is required for execution when EXR is valid.

## A.2 Instruction Codes

Table A.2 shows the instruction codes.

Table A-2 Instruction Codes

Instruction	Mnemonic	Size	Instruction Format																	
			1st byte	2nd byte	3rd byte	4th byte	5th byte	6th byte	7th byte	8th byte	9th byte	10th byte								
ADD	ADD.B #xx:8,Rd	B	8	rd	IMM															
	ADD.B Rs,Rd	B	0	8	rs	rd														
	ADD.W #xx:16,Rd	W	7	9	1	rd	IMM													
	ADD.W Rs,Rd	W	0	9	rs	rd														
	ADD.L #xx:32,ERd	L	7	A	1	0:erd	IMM													
ADDS	ADD.L ERs,ERd	L	0	A	1:ers	0:erd														
	ADDS #1,ERd	L	0	B	0	0:erd														
	ADDS #2,ERd	L	0	B	8	0:erd														
	ADDS #4,ERd	L	0	B	9	0:erd														
	ADDS #xx:8,Rd	B	9	rd	IMM															
ADDX	ADDX Rs,Rd	B	0	E	rs	rd														
	AND.B #xx:8,Rd	B	E	rd	IMM															
	AND.B Rs,Rd	B	1	6	rs	rd														
	AND.W #xx:16,Rd	W	7	9	6	rd	IMM													
	AND.W Rs,Rd	W	6	6	rs	rd														
	AND.L #xx:32,ERd	L	7	A	6	0:erd	IMM													
	AND.L ERs,ERd	L	0	1	F	0	6	6	0:ers	0:erd										
	ANDC #xx:8,CCR	B	0	6	IMM															
	ANDC #xx:8,EXR	B	0	1	4	1	0	6	IMM											
	BAND	BAND #xx:3,Rd	B	7	6	0:IMM	rd													
	BAND #xx:3,@ERd	B	7	C	0:erd	0	7	6	0:IMM	0										
	BAND #xx:3,@aa:8	B	7	E	abs	0	7	6	0:IMM	0										
	BAND #xx:3,@aa:16	B	6	A	1	0	abs	7	6	0:IMM	0									
	BAND #xx:3,@aa:32	B	6	A	3	0	abs	7	6	0:IMM	0									
	Bcc	BRA d:8 (BT d:8)	—	4	0	disp														
	BRN d:16 (BT d:16)	—	5	8	0	0	disp													
	BRN d:8 (BF d:8)	—	4	1	disp															
	BRN d:16 (BF d:16)	—	5	8	1	0	disp													

Instruction	Mnemonic	Size	Instruction Format																	
			1st byte	2nd byte	3rd byte	4th byte	5th byte	6th byte	7th byte	8th byte	9th byte	10th byte								
Bcc	BHI d:8	—	4	2	disp															
	BHI d:16	—	5	8	2	0	disp													
	BLS d:8	—	4	3	disp															
	BLS d:16	—	5	8	3	0	disp													
	BCC d:8 (BHS d:8)	—	4	4	disp															
	BCC d:16 (BHS d:16)	—	5	8	4	0	disp													
	BCS d:8 (BLO d:8)	—	4	5	disp															
	BCS d:16 (BLO d:16)	—	5	8	5	0	disp													
	BNE d:8	—	4	6	disp															
	BNE d:16	—	5	8	6	0	disp													
	BEQ d:8	—	4	7	disp															
	BEQ d:16	—	5	8	7	0	disp													
	BVC d:8	—	4	8	disp															
	BVC d:16	—	5	8	8	0	disp													
	BVS d:8	—	4	9	disp															
	BVS d:16	—	5	8	9	0	disp													
	BPL d:8	—	4	A	disp															
	BPL d:16	—	5	8	A	0	disp													
	BMI d:8	—	4	B	disp															
	BMI d:16	—	5	8	B	0	disp													
BGE d:8	—	4	C	disp																
BGE d:16	—	5	8	C	0	disp														
BLT d:8	—	4	D	disp																
BLT d:16	—	5	8	D	0	disp														
BGT d:8	—	4	E	disp																
BGT d:16	—	5	8	E	0	disp														
BLE d:8	—	4	F	disp																
BLE d:16	—	5	8	F	0	disp														

Instruction	Mnemonic	Size	Instruction Format																		
			1st byte	2nd byte	3rd byte	4th byte	5th byte	6th byte	7th byte	8th byte	9th byte	10th byte									
BCLR	BCLR #xx:3,Rd	B	7	2	0:IMM: rd																
	BCLR #xx:3,@ERd	B	7	D	0:erd 0	7	2	0:IMM: 0													
	BCLR #xx:3,@aa:8	B	7	F	abs	7	2	0:IMM: 0													
	BCLR #xx:3,@aa:16	B	6	A	1 8	abs	7	2	0:IMM: 0												
	BCLR #xx:3,@aa:32	B	6	A	3 8	abs	7	2	0:IMM: 0												
	BCLR Rn,Rd	B	6	2	rn rd																
	BCLR Rn,@ERd	B	7	D	0:erd 0	6	2	rn 0													
	BCLR Rn,@aa:8	B	7	F	abs	6	2	rn 0													
BIAND	BCLR Rn,@aa:16	B	6	A	1 8	abs	6	2	rn 0												
	BCLR Rn,@aa:32	B	6	A	3 8	abs	6	2	rn 0												
	BIAND #xx:3,Rd	B	7	6	1:IMM: rd																
	BIAND #xx:3,@ERd	B	7	C	0:erd 0	7	6	1:IMM: 0													
	BIAND #xx:3,@aa:8	B	7	E	abs	7	6	1:IMM: 0													
	BIAND #xx:3,@aa:16	B	6	A	1 0	abs	7	6	1:IMM: 0												
	BIAND #xx:3,@aa:32	B	6	A	3 0	abs	7	6	1:IMM: 0												
	BILD #xx:3,Rd	B	7	7	1:IMM: rd																
BILD	BILD #xx:3,@ERd	B	7	C	0:erd 0	7	7	1:IMM: 0													
	BILD #xx:3,@aa:8	B	7	E	abs	7	7	1:IMM: 0													
	BILD #xx:3,@aa:16	B	6	A	1 0	abs	7	7	1:IMM: 0												
	BILD #xx:3,@aa:32	B	6	A	3 0	abs	7	7	1:IMM: 0												
	BIOR #xx:3,Rd	B	7	4	1:IMM: rd																
	BIOR #xx:3,@ERd	B	7	C	0:erd 0	7	4	1:IMM: 0													
BIOR	BIOR #xx:3,@aa:8	B	7	E	abs	7	4	1:IMM: 0													
	BIOR #xx:3,@aa:16	B	6	A	1 0	abs	7	4	1:IMM: 0												
	BIOR #xx:3,@aa:32	B	6	A	3 0	abs	7	4	1:IMM: 0												

Instruction	Mnemonic	Size	Instruction Format																	
			1st byte	2nd byte	3rd byte	4th byte	5th byte	6th byte	7th byte	8th byte	9th byte	10th byte								
BIST	BIST #xx:3,Rd	B	6	7	1:IMM; rd															
	BIST #xx:3,@ERd	B	7	D	0:erd 0	6	7	1:IMM; 0												
	BIST #xx:3,@aa:8	B	7	F	abs	6	7	1:IMM; 0												
	BIST #xx:3,@aa:16	B	6	A	1	8	abs	6	7	1:IMM; 0										
	BIST #xx:3,@aa:32	B	6	A	3	8	abs	abs	6	7	1:IMM; 0									
BIXOR	BIXOR #xx:3,Rd	B	7	5	1:IMM; rd															
	BIXOR #xx:3,@ERd	B	7	C	0:erd 0	7	5	1:IMM; 0												
	BIXOR #xx:3,@aa:8	B	7	E	abs	7	5	1:IMM; 0												
	BIXOR #xx:3,@aa:16	B	6	A	1	0	abs	7	5	1:IMM; 0										
	BIXOR #xx:3,@aa:32	B	6	A	3	0	abs	abs	7	5	1:IMM; 0									
BLD	BLD #xx:3,Rd	B	7	7	0:IMM; rd															
	BLD #xx:3,@ERd	B	7	C	0:erd 0	7	7	0:IMM; 0												
	BLD #xx:3,@aa:8	B	7	E	abs	7	7	0:IMM; 0												
	BLD #xx:3,@aa:16	B	6	A	1	0	abs	7	7	0:IMM; 0										
	BLD #xx:3,@aa:32	B	6	A	3	0	abs	abs	7	7	0:IMM; 0									
BNOT	BNOT #xx:3,Rd	B	7	1	0:IMM; rd															
	BNOT #xx:3,@ERd	B	7	D	0:erd 0	7	1	0:IMM; 0												
	BNOT #xx:3,@aa:8	B	7	F	abs	7	1	0:IMM; 0												
	BNOT #xx:3,@aa:16	B	6	A	1	8	abs	7	1	0:IMM; 0										
	BNOT #xx:3,@aa:32	B	6	A	3	8	abs	abs	7	1	0:IMM; 0									
BNOT Rn,Rd	BNOT Rn,Rd	B	6	1	rn rd															
	BNOT Rn,@ERd	B	7	D	0:erd 0	6	1	rn 0												
	BNOT Rn,@aa:8	B	7	F	abs	6	1	rn 0												
	BNOT Rn,@aa:16	B	6	A	1	8	abs	6	1	rn 0										
	BNOT Rn,@aa:32	B	6	A	3	8	abs	abs	6	1	rn 0									

Instruction	Mnemonic	Size	Instruction Format																		
			1st byte	2nd byte	3rd byte	4th byte	5th byte	6th byte	7th byte	8th byte	9th byte	10th byte									
BOR	BOR #xx:3,Rd	B	7	4	0:IMM: rd																
	BOR #xx:3,@ERd	B	7	C	0:erd 0	7	4	0:IMM: 0													
	BOR #xx:3,@aa:8	B	7	E	abs	7	4	0:IMM: 0													
	BOR #xx:3,@aa:16	B	6	A	1	0	abs	7	4	0:IMM: 0											
	BOR #xx:3,@aa:32	B	6	A	3	0	abs				7	4	0:IMM: 0								
	BSET #xx:3,Rd	B	7	0	0:IMM: rd																
BSET	BSET #xx:3,@ERd	B	7	D	0:erd 0	7	0	0:IMM: 0													
	BSET #xx:3,@aa:8	B	7	F	abs	7	0	0:IMM: 0													
	BSET #xx:3,@aa:16	B	6	A	1	8	abs	7	0	0:IMM: 0											
	BSET #xx:3,@aa:32	B	6	A	3	8	abs				7	0	0:IMM: 0								
	BSET Rn,Rd	B	6	0	rn rd																
	BSET Rn,@ERd	B	7	D	0:erd 0	6	0	rn 0													
	BSET Rn,@aa:8	B	7	F	abs	6	0	rn 0													
	BSET Rn,@aa:16	B	6	A	1	8	abs	6	0	rn 0											
	BSET Rn,@aa:32	B	6	A	3	8	abs				6	0	rn 0								
	BSR d:8		—	5	5	disp															
BSR	BSR d:16	—	5	C	0	0	disp														
	BST #xx:3,Rd	B	6	7	0:IMM: rd																
BST	BST #xx:3,@ERd	B	7	D	0:erd 0	6	7	0:IMM: 0													
	BST #xx:3,@aa:8	B	7	F	abs	6	7	0:IMM: 0													
	BST #xx:3,@aa:16	B	6	A	1	8	abs	6	7	0:IMM: 0											
	BST #xx:3,@aa:32	B	6	A	3	8	abs				6	7	0:IMM: 0								
	BTST #xx:3,Rd	B	7	3	0:IMM: rd																
	BTST #xx:3,@ERd	B	7	C	0:erd 0	7	3	0:IMM: 0													
BTST	BTST #xx:3,@aa:8	B	7	E	abs	7	3	0:IMM: 0													
	BTST #xx:3,@aa:16	B	6	A	1	0	abs	7	3	0:IMM: 0											
	BTST #xx:3,@aa:32	B	6	A	3	0	abs				7	3	0:IMM: 0								
	BTST Rn,Rd	B	6	3	rn rd																
	BTST Rn,@ERd	B	7	C	0:erd 0	6	3	rn 0													

Instruction	Mnemonic	Size	Instruction Format																	
			1st byte	2nd byte	3rd byte	4th byte	5th byte	6th byte	7th byte	8th byte	9th byte	10th byte								
BTST	BTST Rn, @aa:8	B	7	E	6	3	rn	0												
	BTST Rn, @aa:16	B	6	A	1	0	abs													
	BTST Rn, @aa:32	B	6	A	3	0	abs								6	3	rn	0		
BXOR	BXOR #xx:3,Rd	B	7	5	0:IMM	rd														
	BXOR #xx:3,@ERd	B	7	C	0:erd	0	7	5	0:IMM	0										
	BXOR #xx:3,@aa:8	B	7	E	abs		7	5	0:IMM	0										
	BXOR #xx:3,@aa:16	B	6	A	1	0	abs													
	BXOR #xx:3,@aa:32	B	6	A	3	0	abs													
	CLRMAC	CLRMAC	—	Cannot be used in the LSI																
CMP	CMP.B #xx:8,Rd	B	A	rd	IMM															
	CMP.B Rs,Rd	B	1	C	rs	rd														
	CMP.W #xx:16,Rd	W	7	9	2	rd	IMM													
	CMP.W Rs,Rd	W	1	D	rs	rd														
	CMP.L #xx:32,ERd	L	7	A	2	0:erd														
	CMP.L ERs,ERd	L	1	F	1:ers	0:erd														
DAA	DAA Rd	B	0	F	0	rd														
DAS	DAS Rd	B	1	F	0	rd														
DEC	DEC.B Rd	B	1	A	0	rd														
	DEC.W #1,Rd	W	1	B	5	rd														
	DEC.W #2,Rd	W	1	B	D	rd														
	DECL #1,ERd	L	1	B	7	0:erd														
	DECL #2,ERd	L	1	B	F	0:erd														
	DIVXS	DIVXS.B Rs,Rd	B	0	1	D	0	5	1	rs	rd									
DIVXU	DIVXS.W Rs,ERd	W	0	1	D	0	5	3	rs	0:erd										
	DIVXU.B Rs,Rd	B	5	1	rs	rd														
	DIVXU.W Rs,ERd	W	5	3	rs	0:erd														
	EEPMOV	EEPMOV.B	—	7	B	5	C	5	9	8	F									
EEPMOV.W	EEPMOV.W	—	7	B	D	4	5	9	8	F										



Instruction	Mnemonic	Size	Instruction Format																					
			1st byte	2nd byte	3rd byte	4th byte	5th byte	6th byte	7th byte	8th byte	9th byte	10th byte												
EXTS	EXTS.W Rd	W	1	7	D	rd																		
	EXTS.L ERd	L	1	7	F	0:erd																		
	EXTU.W Rd	W	1	7	5	rd																		
	EXTU.L ERd	L	1	7	7	0:erd																		
INC	INC.B Rd	B	0	A	0	rd																		
	INC.W #1,Rd	W	0	B	5	rd																		
	INC.W #2,Rd	W	0	B	D	rd																		
	INC.L #1,ERd	L	0	B	7	0:erd																		
	INC.L #2,ERd	L	0	B	F	0:erd																		
	JMP @ERn	—	5	9	0:ern	0																		
JMP	JMP @aa:24	—	5	A																				
	JMP @aa:8	—	5	B	abs																			
	JSR @ERn	—	5	D	0:ern	0																		
	JSR @aa:24	—	5	E																				
	JSR @aa:8	—	5	F	abs																			
	LDC #xx:8,CCR	B	0	7	IMM																			
LDC	LDC #xx:8,EXR	B	0	1	4	1	0	7	IMM															
	LDC Rs,CCR	B	0	3	0	rs																		
	LDC Rs,EXR	B	0	3	1	rs																		
	LDC @ERs,CCR	W	0	1	4	0	6	9	0:ers	0														
	LDC @ERs,EXR	W	0	1	4	1	6	9	0:ers	0														
	LDC @(d:16,ERs),CCR	W	0	1	4	0	6	F	0:ers	0														
	LDC @(d:16,ERs),EXR	W	0	1	4	1	6	F	0:ers	0														
	LDC @(d:32,ERs),CCR	W	0	1	4	0	7	8	0:ers	0														
	LDC @(d:32,ERs),EXR	W	0	1	4	1	7	8	0:ers	0														
	LDC @ERs+,CCR	W	0	1	4	0	6	D	0:ers	0														
LDC @aa:16,EXR	LDC @ERs+,EXR	W	0	1	4	1	6	D	0:ers	0														
	LDC @aa:16,CCR	W	0	1	4	0	6	B	0	0														
	LDC @aa:16,EXR	W	0	1	4	1	6	B	0	0														
	LDC @aa:16,EXR	W	0	1	4	1	6	B	0	0														

Instruction	Mnemonic	Size	Instruction Format																		
			1st byte	2nd byte	3rd byte	4th byte	5th byte	6th byte	7th byte	8th byte	9th byte	10th byte									
LDC	LDC @aa:32,CCR	W	0	1	4	0	6	B	2	0											
	LDC @aa:32,EXR	W	0	1	4	1	6	B	2	0					abs						
LDM	LDM.L @SP+, (ERn-ERn+1)	L	0	1	1	0	6	D	7	0:er{n+1}											
	LDM.L @SP+, (ERn-ERn+2)	L	0	1	2	0	6	D	7	0:er{n+2}											
	LDM.L @SP+, (ERn-ERn+3)	L	0	1	3	0	6	D	7	0:er{n+3}											
	LDMAC	LDMAC ERs,MACH	L	Cannot be used in the LSI																	
MAC	LDMAC ERs,MACL	L																			
	MAC @ERn+, @ERm+	—																			
MOV	MOV.B #xx:8,Rd	B	F	rd	IMM																
	MOV.B Rs,Rd	B	0	C	rs	rd															
	MOV.B @ERS,Rd	B	6	8	0:ers	rd															
	MOV.B @(d:16,ERS),Rd	B	6	E	0:ers	rd				disp											
	MOV.B @(d:32,ERS),Rd	B	7	8	0:ers	0	6	A	2	rd					disp						
	MOV.B @ERS+,Rd	B	6	C	0:ers	rd															
	MOV.B @aa:8,Rd	B	2	rd	abs																
	MOV.B @aa:16,Rd	B	6	A	0	rd				abs											
	MOV.B @aa:32,Rd	B	6	A	2	rd															
	MOV.B Rs,@ERd	B	6	8	1:erd	rs															
	MOV.B Rs,@(d:16,ERd)	B	6	E	1:erd	rs				disp											
	MOV.B Rs,@(d:32,ERd)	B	7	8	0:erd	0	6	A	A	rs					disp						
	MOV.B Rs,@-ERd	B	6	C	1:erd	rs															
	MOV.B Rs,@aa:8	B	3	rs	abs																
	MOV.B Rs,@aa:16	B	6	A	8	rs				abs											
	MOV.B Rs,@aa:32	B	6	A	A	rs															
MOV.W #xx:16,Rd	W	7	9	0	rd				IMM												
MOV.W Rs,Rd	W	0	D	rs	rd																
MOV.W @ERS,Rd	W	6	9	0:ers	rd																
MOV.W @(d:16,ERS),Rd	W	6	F	0:ers	rd				disp												
MOV.W @(d:32,ERS),Rd	W	7	8	0:ers	0	6	B	2	rd					disp							

Instruction	Mnemonic	Size	Instruction Format																		
			1st byte	2nd byte	3rd byte	4th byte	5th byte	6th byte	7th byte	8th byte	9th byte	10th byte									
MOV	MOV.W @ERS+,Rd	W	6	D	0:ers	rd															
	MOV.W @aa:16,Rd	W	6	B	0	rd	abs														
	MOV.W @aa:32,Rd	W	6	B	2	rd	abs														
	MOV.W Rs,@ERd	W	6	9	1:erd	rs															
	MOV.W Rs,@(d:16,ERd)	W	6	F	1:erd	rs	disp														
	MOV.W Rs,@(d:32,ERd)	W	7	8	0:erd	0	6	B	A	rs		disp									
	MOV.W Rs,@-ERd	W	6	D	1:erd	rs															
	MOV.W Rs,@aa:16	W	6	B	8	rs	abs														
	MOV.W Rs,@aa:32	W	6	B	A	rs	abs														
	MOV.L #xx:32,Rd	L	7	A	0	0:erd															
	MOV.L ERs,ERd	L	0	F	1:ers	0:erd															
	MOV.L @ERS,ERd	L	0	1	0	0	6	9	0:ers	0:erd											
	MOV.L @(d:16,ERS),ERd	L	0	1	0	0	6	F	0:ers	0:erd	disp										
	MOV.L @(d:32,ERS),ERd	L	0	1	0	0	7	8	0:ers	0	6	B	2	0:erd	disp						
	MOV.L @ERS+,ERd	L	0	1	0	0	6	D	0:ers	0:erd											
	MOV.L @aa:16,ERd	L	0	1	0	0	6	B	0	0:erd	abs										
	MOV.L @aa:32,ERd	L	0	1	0	0	6	B	2	0:erd	abs										
MOV.L ERs,@ERd	L	0	1	0	0	6	9	1:erd	0:ers												
MOV.L ERs,@(d:16,ERd)	L	0	1	0	0	6	F	1:erd	0:ers	disp											
MOV.L ERs,@(d:32,ERd)*1	L	0	1	0	0	7	8	0:erd	0	6	B	A	0:ers	disp							
MOV.L ERs,@-ERd	L	0	1	0	0	6	D	1:erd	0:ers												
MOV.L ERs,@aa:16	L	0	1	0	0	6	B	8	0:ers	abs											
MOV.L ERs,@aa:32	L	0	1	0	0	6	B	A	0:ers	abs											
MOVPE	MOVPE @aa:16,Rd	B	Cannot be used in the LSI																		
MOVTE	MOVTE Rs,@aa:16	B																			
MULXS	MULXS.B Rs,Rd	B	0	1	C	0	5	0	rs	rd											
	MULXS.W Rs,ERd	W	0	1	C	0	5	2	rs	0:erd											
MULXU	MULXU.B Rs,Rd	B	5	0	rs	rd															
	MULXU.W Rs,ERd	W	5	2	rs	0:erd															

Instruction	Mnemonic	Size	Instruction Format																	
			1st byte	2nd byte	3rd byte	4th byte	5th byte	6th byte	7th byte	8th byte	9th byte	10th byte								
NEG	NEG.B Rd	B	1	7	8	rd														
	NEG.W Rd	W	1	7	9	rd														
	NEG.L ERd	L	1	7	B	0:erd														
NOP	NOP	—	0	0	0	0														
NOT	NOT.B Rd	B	1	7	0	rd														
	NOT.W Rd	W	1	7	1	rd														
	NOT.L ERd	L	1	7	3	0:erd														
	OR	OR.B #xx:8,Rd	B	C	rd	IMM														
	OR.B Rs,Rd	B	1	4	rs	rd														
	OR.W #xx:16,Rd	W	7	9	4	rd	IMM													
	OR.W Rs,Rd	W	6	4	rs	rd														
	OR.L #xx:32,ERd	L	7	A	4	0:erd														
	OR.L ERs,ERd	L	0	1	F	0		6	4	0:ers	0:erd									
ORC	ORC #xx:8,CCR	B	0	4	IMM															
	ORC #xx:8,EXR	B	0	1	4	1		0	4	IMM										
POP	POP.W Rn	W	6	D	7	rn														
	POP.L ERn	L	0	1	0	0		6	D	7	0:ern									
PUSH	PUSH.W Rn	W	6	D	F	rn														
	PUSH.L ERn	L	0	1	0	0		6	D	F	0:ern									
ROTL	ROTL.B Rd	B	1	2	8	rd														
	ROTL.B #2, Rd	B	1	2	C	rd														
	ROTL.W Rd	W	1	2	9	rd														
	ROTL.W #2, Rd	W	1	2	D	rd														
	ROTL.L ERd	L	1	2	B	0:erd														
	ROTL.L #2, ERd	L	1	2	F	0:erd														

Instruction	Mnemonic	Size	Instruction Format																	
			1st byte	2nd byte	3rd byte	4th byte	5th byte	6th byte	7th byte	8th byte	9th byte	10th byte								
ROTR	ROTR.B Rd	B	1	3	8	rd														
	ROTR.B #2, Rd	B	1	3	C	rd														
	ROTR.W Rd	W	1	3	9	rd														
	ROTR.W #2, Rd	W	1	3	D	rd														
	ROTR.L ERd	L	1	3	B	0:erd														
	ROTR.L #2, ERd	L	1	3	F	0:erd														
ROTXL	ROTXL.B Rd	B	1	2	0	rd														
	ROTXL.B #2, Rd	B	1	2	4	rd														
	ROTXL.W Rd	W	1	2	1	rd														
	ROTXL.W #2, Rd	W	1	2	5	rd														
	ROTXL.L ERd	L	1	2	3	0:erd														
	ROTXL.L #2, ERd	L	1	2	7	0:erd														
ROTXR	ROTXR.B Rd	B	1	3	0	rd														
	ROTXR.B #2, Rd	B	1	3	4	rd														
	ROTXR.W Rd	W	1	3	1	rd														
	ROTXR.W #2, Rd	W	1	3	5	rd														
	ROTXR.L ERd	L	1	3	3	0:erd														
	ROTXR.L #2, ERd	L	1	3	7	0:erd														
RTE	RTE	—	5	6	7	0														
RTS	RTS	—	5	4	7	0														
SHAL	SHAL.B Rd	B	1	0	8	rd														
	SHAL.B #2, Rd	B	1	0	C	rd														
	SHAL.W Rd	W	1	0	9	rd														
	SHAL.W #2, Rd	W	1	0	D	rd														
	SHAL.L ERd	L	1	0	B	0:erd														
	SHAL.L #2, ERd	L	1	0	F	0:erd														

Instruction	Mnemonic	Size	Instruction Format																		
			1st byte	2nd byte	3rd byte	4th byte	5th byte	6th byte	7th byte	8th byte	9th byte	10th byte									
SHAR	SHAR.B Rd	B	1	1	8	rd															
	SHAR.B #2, Rd	B	1	1	C	rd															
	SHAR.W Rd	W	1	1	9	rd															
	SHAR.W #2, Rd	W	1	1	D	rd															
	SHAR.L ERd	L	1	1	B	0:erd															
	SHAR.L #2, ERd	L	1	1	F	0:erd															
SHLL	SHLL.B Rd	B	1	0	0	rd															
	SHLL.B #2, Rd	B	1	0	4	rd															
	SHLL.W Rd	W	1	0	1	rd															
	SHLL.W #2, Rd	W	1	0	5	rd															
	SHLL.L ERd	L	1	0	3	0:erd															
	SHLL.L #2, ERd	L	1	0	7	0:erd															
SHLR	SHLR.B Rd	B	1	1	0	rd															
	SHLR.B #2, Rd	B	1	1	4	rd															
	SHLR.W Rd	W	1	1	1	rd															
	SHLR.W #2, Rd	W	1	1	5	rd															
	SHLR.L ERd	L	1	1	3	0:erd															
	SHLR.L #2, ERd	L	1	1	7	0:erd															
SLEEP	SLEEP	—	0	1	8	0															
STC	STC.B COR, Rd	B	0	2	0	rd															
	STC.B EXR, Rd	B	0	2	1	rd															
	STC.W CCR, @ERd	W	0	1	4	0	6	9	1:erd	0											
	STC.W EXR, @ERd	W	0	1	4	1	6	9	1:erd	0											
	STC.W CCR, @(d:16,ERd)	W	0	1	4	0	6	F	1:erd	0											
	STC.W EXR, @(d:16,ERd)	W	0	1	4	1	6	F	1:erd	0											
	STC.W CCR, @(d:32,ERd)	W	0	1	4	0	7	8	0:erd	0	6	B	A	0							disp
	STC.W EXR, @(d:32,ERd)	W	0	1	4	1	7	8	0:erd	0	6	B	A	0							
STC.W CCR, @-ERd	W	0	1	4	0	6	D	1:erd	0												
STC.W EXR, @-ERd	W	0	1	4	1	6	D	1:erd	0												

Instruction	Mnemonic	Size	Instruction Format																		
			1st byte	2nd byte	3rd byte	4th byte	5th byte	6th byte	7th byte	8th byte	9th byte	10th byte									
STC	STC.W CCR, @aa:16	W	0 1	4 0	6 B	8 0		abs													
	STC.W EXR, @aa:16	W	0 1	4 1	6 B	8 0		abs													
	STC.W CCR, @aa:32	W	0 1	4 0	6 B	A 0			abs												
	STC.W EXR, @aa:32	W	0 1	4 1	6 B	A 0			abs												
STM	STML(ERn-ERn+1), @-SP	L	0 1	1 0	6 D	F 0:ern															
	STML(ERn-ERn+2), @-SP	L	0 1	2 0	6 D	F 0:ern															
	STML(ERn-ERn+3), @-SP	L	0 1	3 0	6 D	F 0:ern															
STMAC	STMAC MACH, ERd	L	Cannot be used in the LSI																		
	STMAC MACL, ERd	L																			
SUB	SUB.B Rs, Rd	B	1 8	rs rd																	
	SUB.W #xx:16, Rd	W	7 9	3 rd		IMM															
	SUB.W Rs, Rd	W	1 9	rs rd																	
	SUB.L #xx:32, ERd	L	7 A	3 0:erd			IMM														
	SUB.L ERs, ERd	L	1 A	1:ers 0:erd																	
	SUBS #1, ERd	L	1 B	0 0:erd																	
SUBX	SUBS #2, ERd	L	1 B	8 0:erd																	
	SUBS #4, ERd	L	1 B	9 0:erd																	
	SUBX #xx:8, Rd	B	B rd	IMM																	
	SUBX Rs, Rd	B	1 E	rs rd																	
TAS	TAS @ERd <sup>2</sup>	B	0 1	E 0	7 B	0:erd C															
TRAPA	TRAPA #x:2	—	5 7	00:IMM: 0																	
XOR	XOR.B #xx:8, Rd	B	D rd	IMM																	
	XOR.B Rs, Rd	B	1 5	rs rd																	
	XOR.W #xx:16, Rd	W	7 9	5 rd		IMM															
	XOR.W Rs, Rd	W	6 5	rs rd																	
	XOR.L #xx:32, ERd	L	7 A	5 0:erd			IMM														
XOR.L ERs, ERd	L	0 1	F 0	6 5	0:ers 0:erd																

Instruction	Mnemonic	Size	Instruction Format																		
			1st byte	2nd byte	3rd byte	4th byte	5th byte	6th byte	7th byte	8th byte	9th byte	10th byte									
XORC	XORC #xx:8,CCR	B	0	5	IMM																
	XORC #xx:8,EXR	B	0	1	4	1	0	5	IMM												

Notes: \*1 Bit 7 of the 4th byte of the MOV.L ERs, @(d:32,ERd) instruction can be either 1 or 0.  
 \*2 Only register ER0, ER1, ER4, or ER5 should be used when using the TAS instruction.

#### Legend

IMM: Immediate data (2, 3, 8, 16, or 32 bits)

abs: Absolute address (8, 16, 24, or 32 bits)

disp: Displacement (8, 16, or 32 bits)

rs, rd, rn: Register field (4 bits specifying an 8-bit or 16-bit register. The symbols rs, rd, and rn correspond to operand symbols Rs, Rd, and Rn.)

ers, erd, erm, erm: Register field (3 bits specifying an address register or 32-bit register. The symbols ers, erd, erm, and erm correspond to operand symbols ERs, ERd, ERn, and ERm.)

The register fields specify general registers as follows.

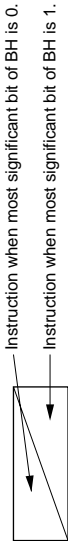
Address Register		16-Bit Register		8-Bit Register	
Register Field	General Register	Register Field	General Register	Register Field	General Register
000	ER0	0000	R0	0000	R0H
001	ER1	0001	R1	0001	R1H
•	•	•	•	•	•
•	•	•	•	•	•
•	•	•	•	•	•
111	ER7	0111	R7	0111	R7H
		1000	E0	1000	R0L
		1001	E1	1001	R1L
		•	•	•	•
		•	•	•	•
		•	•	•	•
		1111	E7	1111	R7L



# A.3 Operation Code Map

Table A.3 shows the operation code map.

**Table A-3 Operation Code Map (1)**



AL/AH	0	1	2	3	4	5	6	7	8	9	A	B	C	D	E	F
0	NOP Table A.3(2)	STC Table A.3(2)	LDC Table A.3(2)	ORC Table A.3(2)	XORC Table A.3(2)	ANDC Table A.3(2)	AND Table A.3(2)	LDC Table A.3(2)	ADD Table A.3(2)	ADD Table A.3(2)	Table A.3(2)	Table A.3(2)	MOV Table A.3(2)	MOV Table A.3(2)	ADDC Table A.3(2)	Table A.3(2)
1	Table A.3(2)	Table A.3(2)	STMAC* Table A.3(2)	LDMAC* Table A.3(2)	OR Table A.3(2)	XOR Table A.3(2)	AND Table A.3(2)	Table A.3(2)	SUB Table A.3(2)	SUB Table A.3(2)	Table A.3(2)	Table A.3(2)	CMP Table A.3(2)	CMP Table A.3(2)	SUBX Table A.3(2)	Table A.3(2)
2	MOV/B															
3	MOV/B															
4	BRA	BRN	BHI	BLS	BCC	BCS	BNE	BEQ	BVC	BVS	BPL	BMI	BGE	BLT	BGT	BLE
5	MULXU	DIVXU	MULXU	DIVXU	RTS	BSR	RTE	TRAPA	Table A.3(2)	Table A.3(2)	JMP	Table A.3(2)	BSR	Table A.3(2)	JSR	Table A.3(2)
6	BSET	BNOT	BCLR	BTST	OR	XOR	AND	BST	MOV	MOV	Table A.3(2)	Table A.3(2)	Table A.3(2)	Table A.3(2)	Table A.3(2)	Table A.3(2)
7					BOR	BXOR	BAND	BLD	MOV	MOV	Table A.3(2)	Table A.3(2)	EEMOV	Table A.3(2)	Table A.3(2)	Table A.3(2)
					BIOR	BIXOR	BAND	BILD	ADD	ADD	ADD	ADD	ADD	ADD	ADD	ADD
8	ADD															
9	ADDX															
A	CMP															
B	SUBX															
C	OR															
D	XOR															
E	AND															
F	MOV															

Note: \* Cannot be used in the LSI.

**Table A-3 Operation Code Map (2)**

Instruction code		1st byte		2nd byte	
		AH	AL	BH	BL

BH/AH	0	1	2	3	4	5	6	7	8	9	A	B	C	D	E	F
01	MOV	LDM		STM	LDC / STC		MAC*		SLEEP		CLRMAC*		Table A.3(3)	Table A.3(3)	TAS	Table A.3(3)
0A	INC	ADD														
0B	ADDS					INC		INC	ADDS					INC		INC
0F	DAA	MOV														
10	SHLL				SHLL			SHLL	SHAL				SHAL			SHAL
11	SHLR				SHLR			SHLR	SHAR				SHAR			SHAR
12	ROTXL				ROTXL			ROTXL	ROTL				ROTL			ROTL
13	ROTXR				ROTXR			ROTXR	ROTR				ROTR			ROTR
17	NOT							EXTU	NEG			NEG				EXTS
1A	DEC	SUB														
1B	SUBS					DEC		DEC	SUBS					DEC		DEC
1F	DAS	CMP														
58	BRA	BRN	BHI	BLS	BCC	BCS	BNE	BEQ	BVC	BVS	BPL	BMI	BGE	BLT	BGT	BLE
6A	MOV	Table A.3(4)	MOV	Table A.3(4)	MOVFP*				MOV		MOV		MOVTYPE*			
79	MOV	ADD	CMP	SUB	OR	XOR	AND									
7A	MOV	ADD	CMP	SUB	OR	XOR	AND									

Note: \* Cannot be used in the LSI.

**Table A-3 Operation Code Map (3)**

Instruction code		1st byte		2nd byte		3rd byte		4th byte	
AH	AL	AH	AL	BH	BL	CH	CL	DH	DL



CL	0	1	2	3	4	5	6	7	8	9	A	B	C	D	E	F
AH/AL/BH/CL	MULXS	MULXS	MULXS													
01C05																
01D05		DIVXS		DIVXS												
01F06					OR	XOR	AND									
7Cr06 *1				BTST												
7Cr07 *1				BTST	BOR	BXOR	BAND	BLD								
7Dr06 *1	BSET	BNOT	BCLR		BIOR	BIXOR	BIAND	BILD	BST							
7Dr07 *1	BSET	BNOT	BCLR													
7Eaa6 *2				BTST												
7Eaa7 *2				BTST	BOR	BXOR	BAND	BLD								
7Faa6 *2	BSET	BNOT	BCLR		BIOR	BIXOR	BIAND	BILD	BST							
7Faa7 *2	BSET	BNOT	BCLR													


Notes: \*1 r is the register specification field.  
 \*2 aa is the absolute address specification.

Table A-3 Operation Code Map (4)

Instruction code	1st byte		2nd byte		3rd byte		4th byte		5th byte		6th byte					
	AH	AL	BH	BL	CH	CL	DH	DL	EH	EL	FH	FL				
<del>AHL BL HL D HL EH</del>	0	1	2	3	4	5	6	7	8	9	A	B	C	D	E	F
6A10aaaa6*				BTST												
6A10aaaa7*					BOR	BXOR	BAND	BLD	BILD							
6A18aaaa6*					BIOR	BIXOR	BIAND	BST								
6A18aaaa7*								BST								
	BSET	BNOT	BCLR													


  
 — Instruction when most significant bit of FH is 0.
   
 — Instruction when most significant bit of FH is 1.

Instruction code	1st byte		2nd byte		3rd byte		4th byte		5th byte		7th byte		8th byte	
	AH	AL	BH	BL	CH	CL	DH	DL	EH	EL	GH	GL	HH	HL
<del>AHL BL ... FHL GH</del>	0	1	2	3	4	5	6	7	8	9	A	B	C	D
6A30aaaaaaa6*				BTST										
6A30aaaaaaa7*					BOR	BXOR	BAND	BLD	BILD					
6A38aaaaaaa6*					BIOR	BIXOR	BIAND	BST						
6A38aaaaaaa7*								BST						
	BSET	BNOT	BCLR											


  
 — Instruction when most significant bit of HH is 0.
   
 — Instruction when most significant bit of HH is 1.

Note: \* aa is the absolute address specification.

## A.4 Number of States Required for Instruction Execution

The tables in this section can be used to calculate the number of states required for instruction execution by the H8S/2000 CPU. Table A.5 indicates the number of instruction fetch, data read/write, and other cycles occurring in each instruction. Table A.4 indicates the number of states required for each cycle, depending on its size. The number of states required for execution of an instruction can be calculated from these two tables as follows:

$$\text{Execution states} = I \times S_I + J \times S_J + K \times S_K + L \times S_L + M \times S_M + N \times S_N$$

**Examples:** Advanced mode, program code and stack located in external memory, on-chip supporting modules accessed in two states with 8-bit bus width, external devices accessed in three states with one wait state and 16-bit bus width.

1. BSET #0, @FFFFB3:8

From table A.5:

$$I = L = 2, \quad J = K = M = N = 0$$

From table A.4:

$$S_I = 4, \quad S_L = 2$$

$$\text{Number of states required for execution} = 2 \times 4 + 2 \times 2 = 12$$

2. JSR @@30

From table A.5:

$$I = J = K = 2, \quad L = M = N = 0$$

From table A.4:

$$S_I = S_J = S_K = 4$$

$$\text{Number of states required for execution} = 2 \times 4 + 2 \times 4 + 2 \times 4 = 24$$

**Table A.4 Number of States per Cycle**

		Access Conditions						
		On-Chip Supporting Module			External Device			
		On-Chip Memory	8-Bit Bus		16-Bit Bus		16-Bit Bus	
8-Bit Bus	16-Bit Bus		2-State Access	3-State Access	2-State Access	3-State Access		
Instruction fetch	$S_I$	1	4	2	4	6 + 2m	2	3 + m
Branch address read	$S_J$							
Stack operation	$S_K$							
Byte data access	$S_L$		2		2	3 + m		
Word data access	$S_M$		4		4	6 + 2m		
Internal operation	$S_N$	1	1	1	1	1	1	1

m: Number of wait states inserted into external device access

**Table A.5 Number of Cycles in Instruction Execution**

Instruction	Mnemonic	Instruction	Branch	Stack	Byte	Word	Internal
		Fetch	Address	Operation	Data	Data	
		I	J	K	L	M	N
ADD	ADD.B #xx:8,Rd	1					
	ADD.B Rs,Rd	1					
	ADD.W #xx:16,Rd	2					
	ADD.W Rs,Rd	1					
	ADD.L #xx:32,ERd	3					
	ADD.L ERs,ERd	1					
ADDS	ADDS #1/2/4,ERd	1					
ADDX	ADDX #xx:8,Rd	1					
	ADDX Rs,Rd	1					
AND	AND.B #xx:8,Rd	1					
	AND.B Rs,Rd	1					
	AND.W #xx:16,Rd	2					
	AND.W Rs,Rd	1					
	AND.L #xx:32,ERd	3					
	AND.L ERs,ERd	2					
ANDC	ANDC #xx:8,CCR	1					
	ANDC #xx:8,EXR	2					
BAND	BAND #xx:3,Rd	1					
	BAND #xx:3,@ERd	2			1		
	BAND #xx:3,@aa:8	2			1		
	BAND #xx:3,@aa:16	3			1		
	BAND #xx:3,@aa:32	4			1		
Bcc	BRA d:8 (BT d:8)	2					
	BRN d:8 (BF d:8)	2					
	BHI d:8	2					
	BLS d:8	2					
	BCC d:8 (BHS d:8)	2					
	BCS d:8 (BLO d:8)	2					
	BNE d:8	2					
	BEQ d:8	2					
	BVC d:8	2					
	BVS d:8	2					
	BPL d:8	2					

Instruction	Mnemonic	Instruction	Branch	Stack	Byte	Word	Internal
		Fetch	Address	Operation	Data	Data	
		I	J	K	L	M	N
Bcc	BMI d:8	2					
	BGE d:8	2					
	BLT d:8	2					
	BGT d:8	2					
	BLE d:8	2					
	BRA d:16 (BT d:16)	2					1
	BRN d:16 (BF d:16)	2					1
	BHI d:16	2					1
	BLS d:16	2					1
	BCC d:16 (BHS d:16)	2					1
	BCS d:16 (BLO d:16)	2					1
	BNE d:16	2					1
	BEQ d:16	2					1
	BVC d:16	2					1
	BVS d:16	2					1
	BPL d:16	2					1
	BMI d:16	2					1
	BGE d:16	2					1
	BLT d:16	2					1
	BGT d:16	2					1
BLE d:16	2					1	
BCLR	BCLR #xx:3,Rd	1					
	BCLR #xx:3,@ERd	2			2		
	BCLR #xx:3,@aa:8	2			2		
	BCLR #xx:3,@aa:16	3			2		
	BCLR #xx:3,@aa:32	4			2		
	BCLR Rn,Rd	1					
	BCLR Rn,@ERd	2			2		
	BCLR Rn,@aa:8	2			2		
	BCLR Rn,@aa:16	3			2		
	BCLR Rn,@aa:32	4			2		



Instruction	Mnemonic	Instruction	Branch	Stack	Byte	Word	Internal
		Fetch	Address	Operation	Data	Data	
		I	J	K	L	M	N
BIAND	BIAND #xx:3,Rd	1					
	BIAND #xx:3,@ERd	2			1		
	BIAND #xx:3,@aa:8	2			1		
	BIAND #xx:3,@aa:16	3			1		
	BIAND #xx:3,@aa:32	4			1		
BILD	BILD #xx:3,Rd	1					
	BILD #xx:3,@ERd	2			1		
	BILD #xx:3,@aa:8	2			1		
	BILD #xx:3,@aa:16	3			1		
	BILD #xx:3,@aa:32	4			1		
BIOR	BIOR #xx:8,Rd	1					
	BIOR #xx:8,@ERd	2			1		
	BIOR #xx:8,@aa:8	2			1		
	BIOR #xx:8,@aa:16	3			1		
	BIOR #xx:8,@aa:32	4			1		
BIST	BIST #xx:3,Rd	1					
	BIST #xx:3,@ERd	2			2		
	BIST #xx:3,@aa:8	2			2		
	BIST #xx:3,@aa:16	3			2		
	BIST #xx:3,@aa:32	4			2		
BIXOR	BIXOR #xx:3,Rd	1					
	BIXOR #xx:3,@ERd	2			1		
	BIXOR #xx:3,@aa:8	2			1		
	BIXOR #xx:3,@aa:16	3			1		
	BIXOR #xx:3,@aa:32	4			1		
BLD	BLD #xx:3,Rd	1					
	BLD #xx:3,@ERd	2			1		
	BLD #xx:3,@aa:8	2			1		
	BLD #xx:3,@aa:16	3			1		
	BLD #xx:3,@aa:32	4			1		

Instruction	Mnemonic	Instruction	Branch	Stack	Byte	Word	Internal
		Fetch	Address	Operation	Data	Data	
		I	J	K	L	M	N
BNOT	BNOT #xx:3,Rd	1					
	BNOT #xx:3,@ERd	2			2		
	BNOT #xx:3,@aa:8	2			2		
	BNOT #xx:3,@aa:16	3			2		
	BNOT #xx:3,@aa:32	4			2		
	BNOT Rn,Rd	1					
	BNOT Rn,@ERd	2			2		
	BNOT Rn,@aa:8	2			2		
	BNOT Rn,@aa:16	3			2		
BNOT Rn,@aa:32	4			2			
BOR	BOR #xx:3,Rd	1					
	BOR #xx:3,@ERd	2			1		
	BOR #xx:3,@aa:8	2			1		
	BOR #xx:3,@aa:16	3			1		
	BOR #xx:3,@aa:32	4			1		
BSET	BSET #xx:3,Rd	1					
	BSET #xx:3,@ERd	2			2		
	BSET #xx:3,@aa:8	2			2		
	BSET #xx:3,@aa:16	3			2		
	BSET #xx:3,@aa:32	4			2		
	BSET Rn,Rd	1					
	BSET Rn,@ERd	2			2		
	BSET Rn,@aa:8	2			2		
	BSET Rn,@aa:16	3			2		
BSET Rn,@aa:32	4			2			
BSR	BSR d:8	2		2			
	BSR d:16	2		2			1
BST	BST #xx:3,Rd	1					
	BST #xx:3,@ERd	2			2		
	BST #xx:3,@aa:8	2			2		
	BST #xx:3,@aa:16	3			2		
	BST #xx:3,@aa:32	4			2		

Instruction	Mnemonic	Instruction	Branch	Stack	Byte	Word	Internal
		Fetch	Address	Operation	Data	Data	
		I	J	K	L	M	N
BTST	BTST #xx:3,Rd	1					
	BTST #xx:3,@ERd	2			1		
	BTST #xx:3,@aa:8	2			1		
	BTST #xx:3,@aa:16	3			1		
	BTST #xx:3,@aa:32	4			1		
	BTST Rn,Rd	1					
	BTST Rn,@ERd	2			1		
	BTST Rn,@aa:8	2			1		
	BTST Rn,@aa:16	3			1		
BTST Rn,@aa:32	4			1			
BXOR	BXOR #xx:3,Rd	1					
	BXOR #xx:3,@ERd	2			1		
	BXOR #xx:3,@aa:8	2			1		
	BXOR #xx:3,@aa:16	3			1		
	BXOR #xx:3,@aa:32	4			1		
CLRMAC	CLRMAC	Cannot be used in the LSI					
CMP	CMP.B #xx:8,Rd	1					
	CMP.B Rs,Rd	1					
	CMP.W #xx:16,Rd	2					
	CMP.W Rs,Rd	1					
	CMP.L #xx:32,ERd	3					
	CMP.L ERs,ERd	1					
DAA	DAA Rd	1					
DAS	DAS Rd	1					
DEC	DEC.B Rd	1					
	DEC.W #1/2,Rd	1					
	DEC.L #1/2,ERd	1					
DIVXS	DIVXS.B Rs,Rd	2					11
	DIVXS.W Rs,ERd	2					19
DIVXU	DIVXU.B Rs,Rd	1					11
	DIVXU.W Rs,ERd	1					19

Instruction	Mnemonic	Instruction	Branch	Stack	Byte	Word	Internal	
		Fetch	Address	Operation	Data	Data		
		I	J	K	L	M	N	
EEPMOV	EEPMOV.B	2			2n+2*2			
	EEPMOV.W	2			2n+2*2			
EXTS	EXTS.W Rd	1						
	EXTS.L ERd	1						
EXTU	EXTU.W Rd	1						
	EXTU.L ERd	1						
INC	INC.B Rd	1						
	INC.W #1/2,Rd	1						
	INC.L #1/2,ERd	1						
JMP	JMP @ERn	2						
	JMP @aa:24	2					1	
	JMP @@aa:8	2	2				1	
JSR	JSR @ERn	2		2				
	JSR @aa:24	2		2			1	
	JSR @@aa:8	2	2	2				
LDC	LDC #xx:8,CCR	1						
	LDC #xx:8,EXR	2						
	LDC Rs,CCR	1						
	LDC Rs,EXR	1						
	LDC @ERs,CCR	2					1	
	LDC @ERs,EXR	2					1	
	LDC @(d:16,ERs),CCR	3					1	
	LDC @(d:16,ERs),EXR	3					1	
	LDC @(d:32,ERs),CCR	5					1	
	LDC @(d:32,ERs),EXR	5					1	
	LDC @ERs+,CCR	2					1	1
	LDC @ERs+,EXR	2					1	1
	LDC @aa:16,CCR	3					1	
	LDC @aa:16,EXR	3					1	
	LDC @aa:32,CCR	4					1	
	LDC @aa:32,EXR	4					1	

Instruction	Mnemonic	Instruction	Branch	Stack	Byte	Word	Internal	
		Fetch	Address	Operation	Data	Data		
		I	J	K	L	M	N	
LDM	LDM.L @SP+, (ERn-ERn+1)	2		4			1	
	LDM.L @SP+, (ERn-ERn+2)	2		6			1	
	LDM.L @SP+, (ERn-ERn+3)	2		8			1	
LDMAC	LDMAC ERs,MACH LDMAC ERs,MACL	Cannot be used in the LSI						
MAC	MAC @ERn+,@ERm+	Cannot be used in the LSI						
MOV	MOV.B #xx:8,Rd	1						
	MOV.B Rs,Rd	1						
	MOV.B @ERs,Rd	1			1			
	MOV.B @(d:16,ERs),Rd	2			1			
	MOV.B @(d:32,ERs),Rd	4			1			
	MOV.B @ERs+,Rd	1			1		1	
	MOV.B @aa:8,Rd	1			1			
	MOV.B @aa:16,Rd	2			1			
	MOV.B @aa:32,Rd	3			1			
	MOV.B Rs,@ERd	1			1			
	MOV.B Rs,@(d:16,ERd)	2			1			
	MOV.B Rs,@(d:32,ERd)	4			1			
	MOV.B Rs,@-ERd	1			1		1	
	MOV.B Rs,@aa:8	1			1			
	MOV.B Rs,@aa:16	2			1			
	MOV.B Rs,@aa:32	3			1			
	MOV.W #xx:16,Rd	2						
	MOV.W Rs,Rd	1						
	MOV.W @ERs,Rd	1					1	
	MOV.W @(d:16,ERs),Rd	2					1	
	MOV.W @(d:32,ERs),Rd	4					1	
	MOV.W @ERs+,Rd	1					1	1
	MOV.W @aa:16,Rd	2					1	
	MOV.W @aa:32,Rd	3					1	
	MOV.W Rs,@ERd	1					1	

Instruction	Mnemonic	Instruction	Branch	Stack	Byte	Word	Internal	
		Fetch	Address	Operation	Data	Data		
		I	J	K	L	M	N	
MOV	MOV.W Rs,@(d:16,ERd)	2				1		
	MOV.W Rs,@(d:32,ERd)	4				1		
	MOV.W Rs,@-ERd	1				1	1	
	MOV.W Rs,@aa:16	2				1		
	MOV.W Rs,@aa:32	3				1		
	MOV.L #xx:32,ERd	3						
	MOV.L ERs,ERd	1						
	MOV.L @ERs,ERd	2					2	
	MOV.L @(d:16,ERs),ERd	3					2	
	MOV.L @(d:32,ERs),ERd	5					2	
	MOV.L @ERs+,ERd	2					2	1
	MOV.L @aa:16,ERd	3					2	
	MOV.L @aa:32,ERd	4					2	
	MOV.L ERs,@ERd	2					2	
	MOV.L ERs,@(d:16,ERd)	3					2	
	MOV.L ERs,@(d:32,ERd)	5					2	
	MOV.L ERs,@-ERd	2					2	1
	MOV.L ERs,@aa:16	3					2	
MOV.L ERs,@aa:32	4					2		
MOVFPPE	MOVFPPE @aa:16,Rd	Can not be used in the LSI						
MOVTPE	MOVTPE Rs,@aa:16							
MULXS	MULXS.B Rs,Rd	2					11	
	MULXS.W Rs,ERd	2					19	
MULXU	MULXU.B Rs,Rd	1					11	
	MULXU.W Rs,ERd	1					19	
NEG	NEG.B Rd	1						
	NEG.W Rd	1						
	NEG.L ERd	1						
NOP	NOP	1						
NOT	NOT.B Rd	1						
	NOT.W Rd	1						
	NOT.L ERd	1						

Instruction	Mnemonic	Instruction	Branch	Stack	Byte	Word	Internal
		Fetch	Address	Operation	Data	Data	
		I	J	K	L	M	N
OR	OR.B #xx:8,Rd	1					
	OR.B Rs,Rd	1					
	OR.W #xx:16,Rd	2					
	OR.W Rs,Rd	1					
	OR.L #xx:32,ERd	3					
	OR.L ERs,ERd	2					
ORC	ORC #xx:8,CCR	1					
	ORC #xx:8,EXR	2					
POP	POP.W Rn	1				1	1
	POP.L ERn	2				2	1
PUSH	PUSH.W Rn	1				1	1
	PUSH.L ERn	2				2	1
ROTL	ROTL.B Rd	1					
	ROTL.B #2,Rd	1					
	ROTL.W Rd	1					
	ROTL.W #2,Rd	1					
	ROTL.L ERd	1					
	ROTL.L #2,ERd	1					
ROTR	ROTR.B Rd	1					
	ROTR.B #2,Rd	1					
	ROTR.W Rd	1					
	ROTR.W #2,Rd	1					
	ROTR.L ERd	1					
	ROTR.L #2,ERd	1					
ROTXL	ROTXL.B Rd	1					
	ROTXL.B #2,Rd	1					
	ROTXL.W Rd	1					
	ROTXL.W #2,Rd	1					
	ROTXL.L ERd	1					
	ROTXL.L #2,ERd	1					

Instruction	Mnemonic	Instruction	Branch	Stack	Byte	Word	Internal
		Fetch	Address	Operation	Data	Data	
		I	J	K	L	M	N
ROTXR	ROTXR.B Rd	1					
	ROTXR.B #2,Rd	1					
	ROTXR.W Rd	1					
	ROTXR.W #2,Rd	1					
	ROTXR.L ERd	1					
	ROTXR.L #2,ERd	1					
RTE	RTE	2		2/3* <sup>1</sup>			1
RTS	RTS	2		2			1
SHAL	SHAL.B Rd	1					
	SHAL.B #2,Rd	1					
	SHAL.W Rd	1					
	SHAL.W #2,Rd	1					
	SHAL.L ERd	1					
	SHAL.L #2,ERd	1					
SHAR	SHAR.B Rd	1					
	SHAR.B #2,Rd	1					
	SHAR.W Rd	1					
	SHAR.W #2,Rd	1					
	SHAR.L ERd	1					
	SHAR.L #2,ERd	1					
SHLL	SHLL.B Rd	1					
	SHLL.B #2,Rd	1					
	SHLL.W Rd	1					
	SHLL.W #2,Rd	1					
	SHLL.L ERd	1					
	SHLL.L #2,ERd	1					
SHLR	SHLR.B Rd	1					
	SHLR.B #2,Rd	1					
	SHLR.W Rd	1					
	SHLR.W #2,Rd	1					
	SHLR.L ERd	1					
	SHLR.L #2,ERd	1					
SLEEP	SLEEP	1					1



Instruction	Mnemonic	Instruction	Branch	Stack	Byte	Word	Internal
		Fetch	Address	Operation	Data	Data	
		I	J	K	L	M	N
STC	STC.B CCR,Rd	1					
	STC.B EXR,Rd	1					
	STC.W CCR,@ERd	2				1	
	STC.W EXR,@ERd	2				1	
	STC.W CCR,@(d:16,ERd)	3				1	
	STC.W EXR,@(d:16,ERd)	3				1	
	STC.W CCR,@(d:32,ERd)	5				1	
	STC.W EXR,@(d:32,ERd)	5				1	
	STC.W CCR,@-ERd	2				1	1
	STC.W EXR,@-ERd	2				1	1
	STC.W CCR,@aa:16	3				1	
	STC.W EXR,@aa:16	3				1	
	STC.W CCR,@aa:32	4				1	
STC.W EXR,@aa:32	4				1		
STM	STM.L (ERn-ERn+1), @-SP	2		4			1
	STM.L (ERn-ERn+2), @-SP	2		6			1
	STM.L (ERn-ERn+3), @-SP	2		8			1
STMAC	STMAC MACH,ERd	Cannot be used in the LSI					
	STMAC MACL,ERd						
SUB	SUB.B Rs,Rd	1					
	SUB.W #xx:16,Rd	2					
	SUB.W Rs,Rd	1					
	SUB.L #xx:32,ERd	3					
	SUB.L ERs,ERd	1					
SUBS	SUBS #1/2/4,ERd	1					
SUBX	SUBX #xx:8,Rd	1					
	SUBX Rs,Rd	1					
TAS	TAS @ERd *3	2			2		
TRAPA	TRAPA #x:2	2	2	2/3*1			2

Instruction	Mnemonic	Instruction	Branch	Stack	Byte	Word	Internal
		Fetch	Address	Operation	Data	Data	
		I	J	K	L	M	N
XOR	XOR.B #xx:8,Rd	1					
	XOR.B Rs,Rd	1					
	XOR.W #xx:16,Rd	2					
	XOR.W Rs,Rd	1					
	XOR.L #xx:32,ERd	3					
	XOR.L ERs,ERd	2					
XORC	XORC #xx:8,CCR	1					
	XORC #xx:8,EXR	2					

Notes: \*1 2 when EXR is invalid, 3 when EXR is valid.

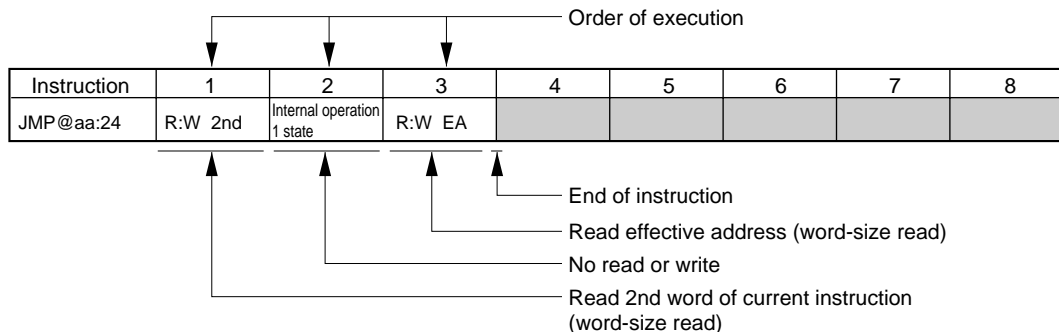
\*2 When n bytes of data are transferred.

\*3 Only register ER0, ER1, ER4, or ER5 should be used when using the TAS instruction.

## A.5 Bus States During Instruction Execution

Table A.6 indicates the types of cycles that occur during instruction execution by the CPU. See table A.4 for the number of states per cycle.

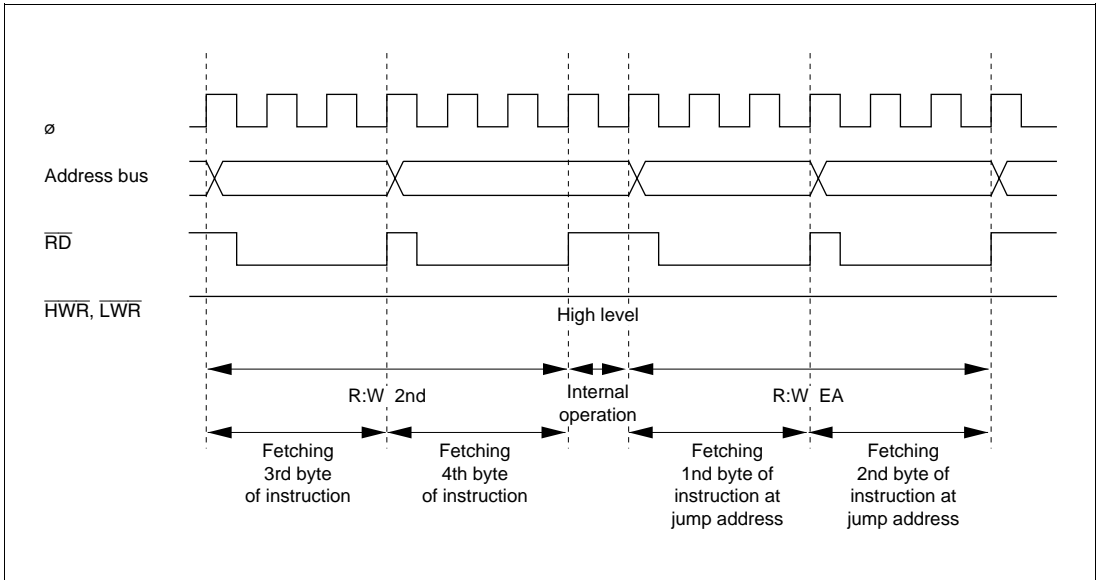
### How to Read the Table:



### Legend

R:B	Byte-size read
R:W	Word-size read
W:B	Byte-size write
W:W	Word-size write
:M	Transfer of the bus is not performed immediately after this cycle
2nd	Address of 2nd word (3rd and 4th bytes)
3rd	Address of 3rd word (5th and 6th bytes)
4th	Address of 4th word (7th and 8th bytes)
5th	Address of 5th word (9th and 10th bytes)
NEXT	Address of next instruction
EA	Effective address
VEC	Vector address

Figure A.1 shows timing waveforms for the address bus and the  $\overline{RD}$ ,  $\overline{HWR}$ , and  $\overline{LWR}$  signals during execution of the above instruction with an 8-bit bus, using three-state access with no wait states.



**Figure A.1 Address Bus,  $\overline{RD}$ ,  $\overline{HWR}$ , and  $\overline{LWR}$  Timing  
(8-Bit Bus, Three-State Access, No Wait States)**

**Table A.6 Instruction Execution Cycles**

Instruction	1	2	3	4	5	6	7	8	9
ADD.B #xx:8,Rd	R:W NEXT								
ADD.B Rs,Rd	R:W NEXT								
ADD.W #xx:16,Rd	R:W 2nd	R:W NEXT							
ADD.W Rs,Rd	R:W NEXT								
ADD.L #xx:32,ERd	R:W 2nd	R:W 3rd	R:W NEXT						
ADD.L ERs,ERd	R:W NEXT								
ADDS #1/2/4,ERd	R:W NEXT								
ADDX #xx:8,Rd	R:W NEXT								
ADDX Rs,Rd	R:W NEXT								
AND.B #xx:8,Rd	R:W NEXT								
AND.B Rs,Rd	R:W NEXT								
AND.W #xx:16,Rd	R:W 2nd	R:W NEXT							
AND.W Rs,Rd	R:W NEXT								
AND.L #xx:32,ERd	R:W 2nd	R:W 3rd	R:W NEXT						
AND.L ERs,ERd	R:W 2nd	R:W NEXT							
ANDC #xx:8,CCR	R:W NEXT								
ANDC #xx:8,EXR	R:W 2nd	R:W NEXT							
BAND #xx:3,Rd	R:W NEXT								
BAND #xx:3,@ERd	R:W 2nd	R:B EA	R:W/M NEXT						
BAND #xx:3,@aa:8	R:W 2nd	R:B EA	R:W/M NEXT						
BAND #xx:3,@aa:16	R:W 2nd	R:W 3rd	R:B EA	R:W/M NEXT					
BAND #xx:3,@aa:32	R:W 2nd	R:W 3rd	R:W 4th	R:B EA	R:W/M NEXT				
BRA d:8 (BT d:8)	R:W NEXT	R:W EA							
BRN d:8 (BF d:8)	R:W NEXT	R:W EA							
BHI d:8	R:W NEXT	R:W EA							
BLS d:8	R:W NEXT	R:W EA							
BCC d:8 (BHS d:8)	R:W NEXT	R:W EA							
BCS d:8 (BLO d:8)	R:W NEXT	R:W EA							
BNE d:8	R:W NEXT	R:W EA							
BEQ d:8	R:W NEXT	R:W EA							
BVC d:8	R:W NEXT	R:W EA							
BVS d:8	R:W NEXT	R:W EA							
BPL d:8	R:W NEXT	R:W EA							
BMI d:8	R:W NEXT	R:W EA							
BGE d:8	R:W NEXT	R:W EA							
BLT d:8	R:W NEXT	R:W EA							
BGT d:8	R:W NEXT	R:W EA							

Instruction	1	2	3	4	5	6	7	8	9
BLE d:8	R:W NEXT	R:W EA							
BRA d:16 (BT d:16)	R:W 2nd	Internal operation, 1 state	R:W EA						
BRN d:16 (BF d:16)	R:W 2nd	Internal operation, 1 state	R:W EA						
BHI d:16	R:W 2nd	Internal operation, 1 state	R:W EA						
BLS d:16	R:W 2nd	Internal operation, 1 state	R:W EA						
BCC d:16 (BHS d:16)	R:W 2nd	Internal operation, 1 state	R:W EA						
BCS d:16 (BLO d:16)	R:W 2nd	Internal operation, 1 state	R:W EA						
BNE d:16	R:W 2nd	Internal operation, 1 state	R:W EA						
BEQ d:16	R:W 2nd	Internal operation, 1 state	R:W EA						
BVC d:16	R:W 2nd	Internal operation, 1 state	R:W EA						
BVS d:16	R:W 2nd	Internal operation, 1 state	R:W EA						
BPL d:16	R:W 2nd	Internal operation, 1 state	R:W EA						
BMI d:16	R:W 2nd	Internal operation, 1 state	R:W EA						
BGE d:16	R:W 2nd	Internal operation, 1 state	R:W EA						
BLT d:16	R:W 2nd	Internal operation, 1 state	R:W EA						
BGT d:16	R:W 2nd	Internal operation, 1 state	R:W EA						
BLE d:16	R:W 2nd	Internal operation, 1 state	R:W EA						
BCLR #xx:3,Rd	R:W NEXT								
BCLR #xx:3,@ERd	R:W 2nd	R:B:M EA	R:W:M NEXT W:B EA						
BCLR #xx:3,@aa:8	R:W 2nd	R:B:M EA	R:W:M NEXT W:B EA						
BCLR #xx:3,@aa:16	R:W 2nd	R:W 3rd	R:B:M EA	R:W:M NEXT W:B EA					

Instruction	1	2	3	4	5	6	7	8	9
BCLR #xx:3,@aa:32	R:W 2nd	R:W 3rd	R:W 4th	R:B:ME A	R:W:M NEXT	W:B EA			
BCLR Rn,Rd	R:W NEXT								
BCLR Rn,@ERd	R:W 2nd	R:B:ME A	R:W:M NEXT	W:B EA					
BCLR Rn,@aa:8	R:W 2nd	R:B:ME A	R:W:M NEXT	W:B EA					
BCLR Rn,@aa:16	R:W 2nd	R:W 3rd	R:B:ME A	R:W:M NEXT	W:B EA				
BCLR Rn,@aa:32	R:W 2nd	R:W 3rd	R:W 4th	R:B:ME A	R:W:M NEXT	W:B EA			
BIAND #xx:3,Rd	R:W NEXT								
BIAND #xx:3,@ERd	R:W 2nd	R:B EA	R:W:M NEXT						
BIAND #xx:3,@aa:8	R:W 2nd	R:B EA	R:W:M NEXT						
BIAND #xx:3,@aa:16	R:W 2nd	R:W 3rd	R:B EA	R:W:M NEXT					
BIAND #xx:3,@aa:32	R:W 2nd	R:W 3rd	R:W 4th	R:B EA	R:W:M NEXT				
BILD #xx:3,Rd	R:W NEXT								
BILD #xx:3,@ERd	R:W 2nd	R:B EA	R:W:M NEXT						
BILD #xx:3,@aa:8	R:W 2nd	R:B EA	R:W:M NEXT						
BILD #xx:3,@aa:16	R:W 2nd	R:W 3rd	R:B EA	R:W:M NEXT					
BILD #xx:3,@aa:32	R:W 2nd	R:W 3rd	R:W 4th	R:B EA	R:W:M NEXT				
BIOR #xx:3,Rd	R:W NEXT								
BIOR #xx:3,@ERd	R:W 2nd	R:B EA	R:W:M NEXT						
BIOR #xx:3,@aa:8	R:W 2nd	R:B EA	R:W:M NEXT						
BIOR #xx:3,@aa:16	R:W 2nd	R:W 3rd	R:B EA	R:W:M NEXT					
BIOR #xx:3,@aa:32	R:W 2nd	R:W 3rd	R:W 4th	R:B EA	R:W:M NEXT				
BIST #xx:3,Rd	R:W NEXT								
BIST #xx:3,@ERd	R:W 2nd	R:B:ME A	R:W:M NEXT	W:B EA					
BIST #xx:3,@aa:8	R:W 2nd	R:B:ME A	R:W:M NEXT	W:B EA					
BIST #xx:3,@aa:16	R:W 2nd	R:W 3rd	R:B:ME A	R:W:M NEXT	W:B EA				
BIST #xx:3,@aa:32	R:W 2nd	R:W 3rd	R:W 4th	R:B:ME A	R:W:M NEXT	W:B EA			
BIXOR #xx:3,Rd	R:W NEXT								
BIXOR #xx:3,@ERd	R:W 2nd	R:B EA	R:W:M NEXT						
BIXOR #xx:3,@aa:8	R:W 2nd	R:B EA	R:W:M NEXT						
BIXOR #xx:3,@aa:16	R:W 2nd	R:W 3rd	R:B EA	R:W:M NEXT					
BIXOR #xx:3,@aa:32	R:W 2nd	R:W 3rd	R:W 4th	R:B EA	R:W:M NEXT				
BLD #xx:3,Rd	R:W NEXT								
BLD #xx:3,@ERd	R:W 2nd	R:B EA	R:W:M NEXT						
BLD #xx:3,@aa:8	R:W 2nd	R:B EA	R:W:M NEXT						
BLD #xx:3,@aa:16	R:W 2nd	R:W 3rd	R:B EA	R:W:M NEXT					
BLD #xx:3,@aa:32	R:W 2nd	R:W 3rd	R:W 4th	R:B EA	R:W:M NEXT				
BNOT #xx:3,Rd	R:W NEXT								

Instruction	1	2	3	4	5	6	7	8	9
BNOT #xx:3,@ERd	R:W 2nd	R:B:M EA	R:W:M NEXT	W:B EA					
BNOT #xx:3,@aa:8	R:W 2nd	R:B:M EA	R:W:M NEXT	W:B EA					
BNOT #xx:3,@aa:16	R:W 2nd	R:W 3rd	R:B:M EA	R:W:M NEXT	W:B EA				
BNOT #xx:3,@aa:32	R:W 2nd	R:W 3rd	R:W 4th	R:B:M EA	R:W:M NEXT	W:B EA			
BNOT Rn,Rd	R:W NEXT								
BNOT Rn,@ERd	R:W 2nd	R:B:M EA	R:W:M NEXT	W:B EA					
BNOT Rn,@aa:8	R:W 2nd	R:B:M EA	R:W:M NEXT	W:B EA					
BNOT Rn,@aa:16	R:W 2nd	R:W 3rd	R:B:M EA	R:W:M NEXT	W:B EA				
BNOT Rn,@aa:32	R:W 2nd	R:W 3rd	R:W 4th	R:B:M EA	R:W:M NEXT	W:B EA			
BOR #xx:3,Rd	R:W NEXT								
BOR #xx:3,@ERd	R:W 2nd	R:B EA	R:W:M NEXT						
BOR #xx:3,@aa:8	R:W 2nd	R:B EA	R:W:M NEXT						
BOR #xx:3,@aa:16	R:W 2nd	R:W 3rd	R:B EA	R:W:M NEXT					
BOR #xx:3,@aa:32	R:W 2nd	R:W 3rd	R:W 4th	R:B EA	R:W:M NEXT				
BSET #xx:3,Rd	R:W NEXT								
BSET #xx:3,@ERd	R:W 2nd	R:B:M EA	R:W:M NEXT	W:B EA					
BSET #xx:3,@aa:8	R:W 2nd	R:B:M EA	R:W:M NEXT	W:B EA					
BSET #xx:3,@aa:16	R:W 2nd	R:W 3rd	R:B:M EA	R:W:M NEXT	W:B EA				
BSET #xx:3,@aa:32	R:W 2nd	R:W 3rd	R:W 4th	R:B:M EA	R:W:M NEXT	W:B EA			
BSET Rn,Rd	R:W NEXT								
BSET Rn,@ERd	R:W 2nd	R:B:M EA	R:W:M NEXT	W:B EA					
BSET Rn,@aa:8	R:W 2nd	R:B:M EA	R:W:M NEXT	W:B EA					
BSET Rn,@aa:16	R:W 2nd	R:W 3rd	R:B:M EA	R:W:M NEXT	W:B EA				
BSET Rn,@aa:32	R:W 2nd	R:W 3rd	R:W 4th	R:B:M EA	R:W:M NEXT	W:B EA			
BSR d:8	R:W NEXT								
BSR d:16	R:W 2nd	Internal operation, 1 state	W:W:M stack (H) R:W EA	W:W stack (L) W:W:M stack (H)					
BST #xx:3,Rd	R:W NEXT								
BST #xx:3,@ERd	R:W 2nd	R:B:M EA	R:W:M NEXT	W:B EA					
BST #xx:3,@aa:8	R:W 2nd	R:B:M EA	R:W:M NEXT	W:B EA					
BST #xx:3,@aa:16	R:W 2nd	R:W 3rd	R:B:M EA	R:W:M NEXT	W:B EA				
BST #xx:3,@aa:32	R:W 2nd	R:W 3rd	R:W 4th	R:B:M EA	R:W:M NEXT	W:B EA			
BTST #xx:3,Rd	R:W NEXT								
BTST #xx:3,@ERd	R:W 2nd	R:B EA	R:W:M NEXT						



Instruction	1	2	3	4	5	6	7	8	9
BTST #xx:3,@aa:8	R:W 2nd	R:B EA	R:W:M NEXT						
BTST #xx:3,@aa:16	R:W 2nd	R:W 3rd	R:B EA	R:W:M NEXT					
BTST #xx:3,@aa:32	R:W 2nd	R:W 3rd	R:W 4th	R:B EA	R:W:M NEXT				
BTST Rn,Rd	R:W NEXT								
BTST Rn,@ERd	R:W 2nd	R:B EA	R:W:M NEXT						
BTST Rn,@aa:8	R:W 2nd	R:B EA	R:W:M NEXT						
BTST Rn,@aa:16	R:W 2nd	R:W 3rd	R:B EA	R:W:M NEXT					
BTST Rn,@aa:32	R:W 2nd	R:W 3rd	R:W 4th	R:B EA	R:W:M NEXT				
BXOR #xx:3,Rd	R:W NEXT								
BXOR #xx:3,@ERd	R:W 2nd	R:B EA	R:W:M NEXT						
BXOR #xx:3,@aa:8	R:W 2nd	R:B EA	R:W:M NEXT						
BXOR #xx:3,@aa:16	R:W 2nd	R:W 3rd	R:B EA	R:W:M NEXT					
BXOR #xx:3,@aa:32	R:W 2nd	R:W 3rd	R:W 4th	R:B EA	R:W:M NEXT				
CLRMAC	Cannot be used in the LSI								
CMP.B #xx:8,Rd	R:W NEXT								
CMP.B Rs,Rd	R:W NEXT								
CMP.W #xx:16,Rd	R:W 2nd	R:W NEXT							
CMP.W Rs,Rd	R:W NEXT								
CMP.L #xx:32,ERd	R:W 2nd	R:W 3rd	R:W NEXT						
CMP.L ERs,ERd	R:W NEXT								
DAA Rd	R:W NEXT								
DAS Rd	R:W NEXT								
DEC.B Rd	R:W NEXT								
DEC.W #1/2,Rd	R:W NEXT								
DEC.L #1/2,ERd	R:W NEXT								
DIVX.S.B Rs,Rd	R:W 2nd	R:W NEXT	Internal operation, 11 states						
DIVX.S.W Rs,ERd	R:W 2nd	R:W NEXT	Internal operation, 19 states						
DIVX.U.B Rs,Rd	R:W NEXT	Internal operation, 11 states							
DIVX.U.W Rs,ERd	R:W NEXT	Internal operation, 19 states							
EEPMOV.B	R:W 2nd	R:B EAs*1	R:B EAd*1	R:B EAs*2	W:B EAd*2	R:W NEXT			
EEPMOV.W	R:W 2nd	R:B EAs*1	R:B EAd*1	R:B EAs*2	W:B EAd*2	R:W NEXT			
EXTS.W Rd	R:W NEXT				← Repeated n times*2 →				
EXTS.L ERd	R:W NEXT								
EXTU.W Rd	R:W NEXT								
EXTU.L ERd	R:W NEXT								
INC.B Rd	R:W NEXT								

Instruction	1	2	3	4	5	6	7	8	9
INC.W #1/2,R,d	R:W NEXT								
INC.L #1/2,ERd	R:W NEXT								
JMP @ERn	R:W NEXT	R:W EA							
JMP @aa:24	Internal operation, 1 state	R:W EA							
JMP @aa:8	R:W NEXT	R:W:M aa:8	R:W aa:8	Internal operation, 1 state	R:W EA				
JSR @ERn	R:W NEXT	R:W EA	W:W:M stack (H)	W:W stack (L)					
JSR @aa:24	Internal operation, 1 state	R:W EA	R:W EA	W:W:M stack (H)	W:W stack (L)				
JSR @aa:8	R:W NEXT	R:W:M aa:8	R:W aa:8	W:W:M stack (H)	W:W stack (L)	R:W EA			
LDC #xx:8,CCR	R:W NEXT								
LDC #xx:8,EXR	R:W 2nd	R:W NEXT							
LDC Rs,CCR	R:W NEXT								
LDC Rs,EXR	R:W NEXT								
LDC @ERs,CCR	R:W 2nd	R:W NEXT	R:W EA						
LDC @ERs,EXR	R:W 2nd	R:W NEXT	R:W EA						
LDC @(d:16,ERs),CCR	R:W 2nd	R:W 3rd	R:W NEXT	R:W EA					
LDC @(d:16,ERs),EXR	R:W 2nd	R:W 3rd	R:W NEXT	R:W EA					
LDC @(d:32,ERs),CCR	R:W 2nd	R:W 3rd	R:W 4th	R:W 5th	R:W NEXT	R:W EA			
LDC @(d:32,ERs),EXR	R:W 2nd	R:W 3rd	R:W 4th	R:W 5th	R:W NEXT	R:W EA			
LDC @ERs+,CCR	R:W 2nd	R:W NEXT	Internal operation, 1 state	R:W EA					
LDC @ERs+,EXR	R:W 2nd	R:W NEXT	Internal operation, 1 state	R:W EA					
LDC @aa:16,CCR	R:W 2nd	R:W 3rd	R:W NEXT	R:W EA					
LDC @aa:16,EXR	R:W 2nd	R:W 3rd	R:W NEXT	R:W EA					
LDC @aa:32,CCR	R:W 2nd	R:W 3rd	R:W 4th	R:W NEXT	R:W EA				
LDC @aa:32,EXR	R:W 2nd	R:W 3rd	R:W 4th	R:W NEXT	R:W EA				
LDM.L @SP+, (ERn-ERn+1)	R:W 2nd	R:W:M NEXT	Internal operation, 1 state	R:W stack (H) <sup>*3</sup>	R:W stack (L) <sup>*3</sup>				
LDML @SP+,(ERn-ERn+2)	R:W 2nd	R:W NEXT	Internal operation, 1 state	R:W:M stack (H) <sup>*3</sup>	R:W stack (L) <sup>*3</sup>				
LDML @SP+,(ERn-ERn+3)	R:W 2nd	R:W NEXT	Internal operation, 1 state	R:W:M stack (H) <sup>*3</sup>	R:W stack (L) <sup>*3</sup>				
LDMAC ERs,MACH	Cannot be used in the LSI								

Instruction	1	2	3	4	5	6	7	8	9
LDMAC ERs, MACL	Cannot be used in the LSI								
MAC @ERn+, @ERm+									
MOV.B #xx:8,Rd	R:W NEXT								
MOV.B Rs,Rd	R:W NEXT								
MOV.B @ERs,Rd	R:W NEXT	R:B EA							
MOV.B @(d:16,ERs),Rd	R:W 2nd	R:W NEXT	R:B EA						
MOV.B @(d:32,ERs),Rd	R:W 2nd	R:W 3rd	R:W 4th	R:W NEXT	R:B EA				
MOV.B @ERs+,Rd	R:W NEXT	Internal operation, 1 state	R:B EA						
MOV.B @aa:8,Rd	R:W NEXT	R:B EA							
MOV.B @aa:16,Rd	R:W 2nd	R:W NEXT	R:B EA						
MOV.B @aa:32,Rd	R:W 2nd	R:W 3rd	R:W NEXT	R:B EA					
MOV.B Rs,@ERd	R:W NEXT	W:B EA							
MOV.B Rs,@(d:16,ERd)	R:W 2nd	R:W NEXT	W:B EA						
MOV.B Rs,@(d:32,ERd)	R:W 2nd	R:W 3rd	R:W 4th	R:W NEXT	W:B EA				
MOV.B Rs,@-ERd	R:W NEXT	Internal operation, 1 state	W:B EA						
MOV.B Rs,@aa:8	R:W NEXT	W:B EA							
MOV.B Rs,@aa:16	R:W 2nd	R:W NEXT	W:B EA						
MOV.B Rs,@aa:32	R:W 2nd	R:W 3rd	R:W NEXT	W:B EA					
MOV.W #xx:16,Rd	R:W 2nd	R:W NEXT							
MOV.W Rs,Rd	R:W NEXT								
MOV.W @ERs,Rd	R:W NEXT	R:W EA							
MOV.W @(d:16,ERs),Rd	R:W 2nd	R:W NEXT	R:W EA						
MOV.W @(d:32,ERs),Rd	R:W 2nd	R:W 3rd	R:W 4th	R:W NEXT	R:W EA				
MOV.W @ERs+,Rd	R:W NEXT	Internal operation, 1 state	R:W EA						
MOV.W @aa:16,Rd	R:W 2nd	R:W NEXT	R:W EA						
MOV.W @aa:32,Rd	R:W 2nd	R:W 3rd	R:W NEXT	R:B EA					
MOV.W Rs,@ERd	R:W NEXT	W:W EA							
MOV.W Rs,@(d:16,ERd)	R:W 2nd	R:W NEXT	W:W EA						
MOV.W Rs,@(d:32,ERd)	R:W 2nd	R:W 3rd	R:W 4th	R:W NEXT	W:W EA				
MOV.W Rs,@-ERd	R:W NEXT	Internal operation, 1 state	W:W EA						
MOV.W Rs,@aa:16	R:W 2nd	R:W NEXT	W:W EA						
MOV.W Rs,@aa:32	R:W 2nd	R:W 3rd	R:W NEXT	W:W EA					

Instruction	1	2	3	4	5	6	7	8	9
MOV.L #xx:32,ERd	R:W 2nd	R:W 3rd	R:W NEXT						
MOV.L ERs,ERd	R:W NEXT								
MOV.L @ERs,ERd	R:W 2nd	R:W:M NEXT	R:W:MEA	R:W EA+2					
MOV.L @(d:16,ERs),ERd	R:W 2nd	R:W:M 3rd	R:W NEXT	R:W:MEA	R:W EA+2				
MOV.L @(d:32,ERs),ERd	R:W 2nd	R:W:M 3rd	R:W:M 4th	R:W 5th	R:W NEXT	R:W:MEA	R:W EA+2		
MOV.L @ERs+,ERd	R:W 2nd	R:W:M NEXT	Internal operation, 1 state	R:W:M EA	R:W EA+2				
MOV.L @aa:16,ERd	R:W 2nd	R:W:M 3rd	R:W NEXT	R:W:MEA	R:W EA+2				
MOV.L @aa:32,ERd	R:W 2nd	R:W:M 3rd	R:W 4th	R:W NEXT	R:W:M EA	R:W EA+2			
MOV.L ERs,@ERd	R:W 2nd	R:W:M NEXT	W:W:MEA	W:W EA+2					
MOV.L ERs,@(d:16,ERd)	R:W 2nd	R:W:M 3rd	R:W NEXT	W:W:MEA	W:W EA+2				
MOV.L ERs,@(d:32,ERd)	R:W 2nd	R:W:M 3rd	R:W:M 4th	R:W 5th	R:W NEXT	W:W:MEA	W:W EA+2		
MOV.L ERs,@-ERd	R:W 2nd	R:W:M NEXT	Internal operation, 1 state	W:W:MEA	W:W EA+2				
MOV.L ERs @aa:16	R:W 2nd	R:W:M 3rd	R:W NEXT	W:W:MEA	W:W EA+2				
MOV.L ERs @aa:32	R:W 2nd	R:W:M 3rd	R:W 4th	R:W NEXT	W:W:MEA	W:W EA+2			
MOV.FPE @aa:16,Rd	Cannot be used in the LSI								
MOV.TPE Rs,@aa:16									
MULX.S B Rs,Rd	R:W 2nd	R:W NEXT	Internal operation, 11 states						
MULX.S W Rs,ERd	R:W 2nd	R:W NEXT	Internal operation, 19 states						
MULX.U B Rs,Rd	R:W NEXT	Internal operation, 11 states							
MULX.U W Rs,ERd	R:W NEXT	Internal operation, 19 states							
NEG.B Rd	R:W NEXT								
NEG.W Rd	R:W NEXT								
NEG.L ERd	R:W NEXT								
NOP	R:W NEXT								
NOT.B Rd	R:W NEXT								
NOT.L ERd	R:W NEXT								
OR.B #xx:8,Rd	R:W NEXT								
OR.B Rs,Rd	R:W NEXT								
OR.W #xx:16,Rd	R:W 2nd	R:W NEXT							
OR.W Rs,Rd	R:W NEXT								
OR.L #xx:32,ERd	R:W 2nd	R:W 3rd	R:W NEXT						
OR.L ERs,ERd	R:W 2nd	R:W NEXT							
ORC #xx:8,CCR	R:W NEXT								
ORC #xx:8,EXR	R:W 2nd	R:W NEXT							

Instruction	1	2	3	4	5	6	7	8	9
POP.W Rn	R:W NEXT	Internal operation, 1 state	R:W EA						
POP.L ERn	R:W 2nd	R:W:M NEXT 1 state	Internal operation, 1 state	R:W:M EA	R:W EA+2				
PUSH.W Rn	R:W NEXT	Internal operation, 1 state	W:W EA						
PUSH.L ERn	R:W 2nd	R:W:M NEXT 1 state	Internal operation, 1 state	W:W:M EA	W:W EA+2				
ROTL.B Rd	R:W NEXT								
ROTL.B #2,Rd	R:W NEXT								
ROTL.W Rd	R:W NEXT								
ROTL.W #2,Rd	R:W NEXT								
ROTL.L ERd	R:W NEXT								
ROTL.L #2,ERd	R:W NEXT								
ROTR.B Rd	R:W NEXT								
ROTR.B #2,Rd	R:W NEXT								
ROTR.W Rd	R:W NEXT								
ROTR.W #2,Rd	R:W NEXT								
ROTR.L ERd	R:W NEXT								
ROTR.L #2,ERd	R:W NEXT								
ROTXL.B Rd	R:W NEXT								
ROTXL.B #2,Rd	R:W NEXT								
ROTXL.W Rd	R:W NEXT								
ROTXL.W #2,Rd	R:W NEXT								
ROTXL.L ERd	R:W NEXT								
ROTXL.L #2,ERd	R:W NEXT								
ROTXR.B Rd	R:W NEXT								
ROTXR.B #2,Rd	R:W NEXT								
ROTXR.W Rd	R:W NEXT								
ROTXR.W #2,Rd	R:W NEXT								
ROTXR.L ERd	R:W NEXT								
ROTXR.L #2,ERd	R:W NEXT								
RTE	R:W NEXT	R:W stack (EXR)	R:W stack (H)	R:W stack (L)	Internal operation, 1 state	R:W <sup>2</sup> 4			
RTS	R:W NEXT	R:W:M stack (H)	R:W stack (L)	Internal operation, 1 state	R:W <sup>2</sup> 4				
SHAL.B Rd	R:W NEXT								

Instruction	1	2	3	4	5	6	7	8	9
SHAL.B #2,Rd	R:W NEXT								
SHAL.W Rd	R:W NEXT								
SHAL.W #2,Rd	R:W NEXT								
SHAL.L ERd	R:W NEXT								
SHAL.L #2,ERd	R:W NEXT								
SHAR.B Rd	R:W NEXT								
SHAR.B #2,Rd	R:W NEXT								
SHAR.W Rd	R:W NEXT								
SHAR.W #2,Rd	R:W NEXT								
SHAR.L ERd	R:W NEXT								
SHAR.L #2,ERd	R:W NEXT								
SHLL.B Rd	R:W NEXT								
SHLL.B #2,Rd	R:W NEXT								
SHLL.W Rd	R:W NEXT								
SHLL.W #2,Rd	R:W NEXT								
SHLL.L ERd	R:W NEXT								
SHLL.L #2,ERd	R:W NEXT								
SHLR.B Rd	R:W NEXT								
SHLR.B #2,Rd	R:W NEXT								
SHLR.W Rd	R:W NEXT								
SHLR.W #2,Rd	R:W NEXT								
SHLR.L ERd	R:W NEXT								
SHLR.L #2,ERd	R:W NEXT								
SLEEP	R:W NEXT	Internal operation:M							
STC CCR,Rd	R:W NEXT								
STC CCR,@ERd	R:W NEXT								
STC CCR,@ERd	R:W 2nd	R:W NEXT	W:W EA						
STC EXR,@ERd	R:W 2nd	R:W NEXT	W:W EA						
STC CCR,@(d:16,ERd)	R:W 2nd	R:W 3rd	R:W NEXT	W:W EA					
STC EXR,@(d:16,ERd)	R:W 2nd	R:W 3rd	R:W NEXT	W:W EA					
STC CCR,@(d:32,ERd)	R:W 2nd	R:W 3rd	R:W 4th	R:W 5th	R:W NEXT	W:W EA			
STC EXR,@(d:32,ERd)	R:W 2nd	R:W 3rd	R:W 4th	R:W 5th	R:W NEXT	W:W EA			
STC CCR,@-ERd	R:W 2nd	R:W NEXT	Internal operation, 1 state	W:W EA					

Instruction	1	2	3	4	5	6	7	8	9
STC EXR, @-ERd	R:W 2nd	R:W NEXT	Internal operation, 1 state	W:W EA					
STC CCR, @aa:16	R:W 2nd	R:W 3rd	R:W NEXT	W:W EA					
STC EXR, @aa:16	R:W 2nd	R:W 3rd	R:W NEXT	W:W EA					
STC CCR, @aa:32	R:W 2nd	R:W 3rd	R:W 4th	R:W NEXT	W:W EA				
STC EXR, @aa:32	R:W 2nd	R:W 3rd	R:W 4th	R:W NEXT	W:W EA				
STM.L(ERn-ERn+1),@-SP	R:W 2nd	R:W:M NEXT	Internal operation, 1 state	W:W:M stack (H) <sup>*3</sup>	W:W stack (L) <sup>*3</sup>				
STM.L(ERn-ERn+2),@-SP	R:W 2nd	R:W:M NEXT	Internal operation, 1 state	W:W:M stack (H) <sup>*3</sup>	W:W stack (L) <sup>*3</sup>				
STM.L(ERn-ERn+3),@-SP	R:W 2nd	R:W:M NEXT	Internal operation, 1 state	W:W:M stack (H) <sup>*3</sup>	W:W stack (L) <sup>*3</sup>				
STMAC MACH.ERd	Cannot be used in the LSI								
STMAC MACL.ERd	Cannot be used in the LSI								
SUB.B Rs,Rd	R:W NEXT								
SUB.W #xx:16,Rd	R:W 2nd	R:W NEXT							
SUB.W Rs,Rd	R:W NEXT								
SUB.L #xx:32,ERd	R:W 2nd	R:W 3rd	R:W NEXT						
SUB.L ERs,ERd	R:W NEXT								
SUBS #1/2/4,ERd	R:W NEXT								
SUBX #xx:8,Rd	R:W NEXT								
SUBX Rs,Rd	R:W NEXT								
TAS @ERd <sup>*5</sup>	R:W 2nd	R:W NEXT	R:B:M EA	W:B EA					
TRAPA #x:2	R:W NEXT	Internal operation, 1 state	W:W stack (L)	W:W stack (H)	W:W stack (EXR)	R:W:M VEC	R:W VEC+2	Internal operation, 1 state	R:W <sup>*8</sup>
XOR.B #xx:8,Rd	R:W NEXT								
XOR.B Rs,Rd	R:W NEXT								
XOR.W #xx:16,Rd	R:W 2nd	R:W NEXT							
XOR.W Rs,Rd	R:W NEXT								
XOR.L #xx:32,ERd	R:W 2nd	R:W 3rd	R:W NEXT						
XOR.L ERs,ERd	R:W 2nd	R:W NEXT							
XORC #xx:8,CCR	R:W NEXT								
XORC #xx:8,EXR	R:W 2nd	R:W NEXT							
Reset exception handling	R:W:M VEC	R:W VEC+2	Internal operation, 1 state	R:W <sup>*6</sup>					

Instruction	1	2	3	4	5	6	7	8	9
Interrupt exception handling	R:W*7	Internal operation, 1 state	W:W stack (L)	W:W stack (H)	W:W stack (EXR)	R:W:M VEC	R:W VEC+2	Internal operation, 1 state	R:W*8

Notes: \*1 EAs is the contents of ER5. EAd is the contents of ER6.

\*2 EAs is the contents of ER5. EAd is the contents of ER6. Both registers are incremented by 1 after execution of the instruction. n is the initial value of R4L or R4. If n = 0, these bus cycles are not executed.

\*3 Repeated two times to save or restore two registers, three times for three registers, or four times for four registers.

\*4 Start address after return.

\*5 Only register ER0, ER1, ER4, or ER5 should be used when using the TAS instruction.

\*6 Start address of the program.

\*7 Prefetch address, equal to two plus the PC value pushed onto the stack. In recovery from sleep mode or software standby mode the read operation is replaced by an internal operation.

\*8 Start address of the interrupt-handling routine.



## A.6 Condition Code Modification

This section indicates the effect of each CPU instruction on the condition code. The notation used in the table is defined below.

$$m = \begin{cases} 31 & \text{for longword operands} \\ 15 & \text{for word operands} \\ 7 & \text{for byte operands} \end{cases}$$

Si	The i-th bit of the source operand
Di	The i-th bit of the destination operand
Ri	The i-th bit of the result
Dn	The specified bit in the destination operand
—	Not affected
↕	Modified according to the result of the instruction (see definition)
0	Always cleared to 0
1	Always set to 1
*	Undetermined (no guaranteed value)
Z'	Z flag before instruction execution
C'	C flag before instruction execution

**Table A.7 Condition Code Modification**

Instruction	H	N	Z	V	C	Definition
ADD	↓	↓	↓	↓	↓	$H = S_{m-4} \cdot D_{m-4} + D_{m-4} \cdot \overline{R_{m-4}} + S_{m-4} \cdot \overline{R_{m-4}}$ $N = R_m$ $Z = \overline{R_m} \cdot \overline{R_{m-1}} \cdot \dots \cdot \overline{R_0}$ $V = S_m \cdot D_m \cdot \overline{R_m} + \overline{S_m} \cdot \overline{D_m} \cdot R_m$ $C = S_m \cdot D_m + D_m \cdot \overline{R_m} + S_m \cdot \overline{R_m}$
ADDS	—	—	—	—	—	
ADDX	↓	↓	↓	↓	↓	$H = S_{m-4} \cdot D_{m-4} + D_{m-4} \cdot \overline{R_{m-4}} + S_{m-4} \cdot \overline{R_{m-4}}$ $N = R_m$ $Z = Z' \cdot \overline{R_m} \cdot \dots \cdot \overline{R_0}$ $V = S_m \cdot D_m \cdot \overline{R_m} + \overline{S_m} \cdot \overline{D_m} \cdot R_m$ $C = S_m \cdot D_m + D_m \cdot \overline{R_m} + S_m \cdot \overline{R_m}$
AND	—	↓	↓	0	—	$N = R_m$ $Z = \overline{R_m} \cdot \overline{R_{m-1}} \cdot \dots \cdot \overline{R_0}$
ANDC	↓	↓	↓	↓	↓	Stores the corresponding bits of the result. No flags change when the operand is EXR.
BAND	—	—	—	—	↓	$C = C' \cdot D_n$
Bcc	—	—	—	—	—	
BCLR	—	—	—	—	—	
BIAND	—	—	—	—	↓	$C = C' \cdot \overline{D_n}$
BILD	—	—	—	—	↓	$C = \overline{D_n}$
BIOR	—	—	—	—	↓	$C = C' + \overline{D_n}$
BIST	—	—	—	—	—	
BIXOR	—	—	—	—	↓	$C = C' \cdot D_n + \overline{C'} \cdot \overline{D_n}$
BLD	—	—	—	—	↓	$C = D_n$
BNOT	—	—	—	—	—	
BOR	—	—	—	—	↓	$C = C' + D_n$
BSET	—	—	—	—	—	
BSR	—	—	—	—	—	
BST	—	—	—	—	—	
BTST	—	—	↓	—	—	$Z = D_n$
BXOR	—	—	—	—	↓	$C = C' \cdot \overline{D_n} + \overline{C'} \cdot D_n$
CLRMAC						Cannot be used in the LSI

Instruction	H	N	Z	V	C	Definition
CMP	↕	↕	↕	↕	↕	$H = S_{m-4} \cdot \overline{D_{m-4}} + \overline{D_{m-4}} \cdot R_{m-4} + S_{m-4} \cdot R_{m-4}$ $N = R_m$ $Z = \overline{R_m} \cdot \overline{R_{m-1}} \cdot \dots \cdot \overline{R_0}$ $V = \overline{S_m} \cdot D_m \cdot \overline{R_m} + S_m \cdot \overline{D_m} \cdot R_m$ $C = S_m \cdot \overline{D_m} + \overline{D_m} \cdot R_m + S_m \cdot R_m$
DAA	*	↕	↕	*	↕	$N = R_m$ $Z = \overline{R_m} \cdot \overline{R_{m-1}} \cdot \dots \cdot \overline{R_0}$ C: decimal arithmetic carry
DAS	*	↕	↕	*	↕	$N = R_m$ $Z = \overline{R_m} \cdot \overline{R_{m-1}} \cdot \dots \cdot \overline{R_0}$ C: decimal arithmetic borrow
DEC	—	↕	↕	↕	—	$N = R_m$ $Z = \overline{R_m} \cdot \overline{R_{m-1}} \cdot \dots \cdot \overline{R_0}$ $V = D_m \cdot \overline{R_m}$
DIVXS	—	↕	↕	—	—	$N = S_m \cdot \overline{D_m} + \overline{S_m} \cdot D_m$ $Z = \overline{S_m} \cdot \overline{S_{m-1}} \cdot \dots \cdot \overline{S_0}$
DIVXU	—	↕	↕	—	—	$N = S_m$ $Z = \overline{S_m} \cdot \overline{S_{m-1}} \cdot \dots \cdot \overline{S_0}$
EEPMOV	—	—	—	—	—	
EXTS	—	↕	↕	0	—	$N = R_m$ $Z = \overline{R_m} \cdot \overline{R_{m-1}} \cdot \dots \cdot \overline{R_0}$
EXTU	—	0	↕	0	—	$Z = \overline{R_m} \cdot \overline{R_{m-1}} \cdot \dots \cdot \overline{R_0}$
INC	—	↕	↕	↕	—	$N = R_m$ $Z = \overline{R_m} \cdot \overline{R_{m-1}} \cdot \dots \cdot \overline{R_0}$ $V = \overline{D_m} \cdot R_m$
JMP	—	—	—	—	—	
JSR	—	—	—	—	—	
LDC	↕	↕	↕	↕	↕	Stores the corresponding bits of the result. No flags change when the operand is EXR.
LDM	—	—	—	—	—	
LDMAC						Cannot be used in the LSI
MAC						

Instruction	H	N	Z	V	C	Definition
MOV	—	↕	↕	0	—	$N = Rm$ $Z = \overline{Rm} \cdot \overline{Rm-1} \cdot \dots \cdot \overline{R0}$
MOVFPPE						Can not be used in the LSI
MOVTPE						
MULXS	—	↕	↕	—	—	$N = R2m$ $Z = \overline{R2m} \cdot \overline{R2m-1} \cdot \dots \cdot \overline{R0}$
MULXU	—	—	—	—	—	
NEG	↕	↕	↕	↕	↕	$H = Dm-4 + Rm-4$ $N = Rm$ $Z = \overline{Rm} \cdot \overline{Rm-1} \cdot \dots \cdot \overline{R0}$ $V = Dm \cdot Rm$ $C = Dm + Rm$
NOP	—	—	—	—	—	
NOT	—	↕	↕	0	—	$N = Rm$ $Z = \overline{Rm} \cdot \overline{Rm-1} \cdot \dots \cdot \overline{R0}$
OR	—	↕	↕	0	—	$N = Rm$ $Z = \overline{Rm} \cdot \overline{Rm-1} \cdot \dots \cdot \overline{R0}$
ORC	↕	↕	↕	↕	↕	Stores the corresponding bits of the result. No flags change when the operand is EXR.
POP	—	↕	↕	0	—	$N = Rm$ $Z = \overline{Rm} \cdot \overline{Rm-1} \cdot \dots \cdot \overline{R0}$
PUSH	—	↕	↕	0	—	$N = Rm$ $Z = \overline{Rm} \cdot \overline{Rm-1} \cdot \dots \cdot \overline{R0}$
ROTL	—	↕	↕	0	↕	$N = Rm$ $Z = \overline{Rm} \cdot \overline{Rm-1} \cdot \dots \cdot \overline{R0}$ $C = Dm$ (1-bit shift) or $C = Dm-1$ (2-bit shift)
ROTR	—	↕	↕	0	↕	$N = Rm$ $Z = \overline{Rm} \cdot \overline{Rm-1} \cdot \dots \cdot \overline{R0}$ $C = D0$ (1-bit shift) or $C = D1$ (2-bit shift)

Instruction	H	N	Z	V	C	Definition
ROTXL	—	↓	↓	0	↓	N = Rm Z = $\overline{Rm} \cdot \overline{Rm-1} \cdot \dots \cdot \overline{R0}$ C = Dm (1-bit shift) or C = Dm-1 (2-bit shift)
ROTXR	—	↓	↓	0	↓	N = Rm Z = $\overline{Rm} \cdot \overline{Rm-1} \cdot \dots \cdot \overline{R0}$ C = D0 (1-bit shift) or C = D1 (2-bit shift)
RTE	↓	↓	↓	↓	↓	Stores the corresponding bits of the result.
RTS	—	—	—	—	—	
SHAL	—	↓	↓	↓	↓	N = Rm Z = $\overline{Rm} \cdot \overline{Rm-1} \cdot \dots \cdot \overline{R0}$ V = $\overline{Dm} \cdot \overline{Dm-1} + \overline{Dm} \cdot \overline{Dm-1}$ (1-bit shift) V = $\overline{Dm} \cdot \overline{Dm-1} \cdot \overline{Dm-2} \cdot \overline{Dm} \cdot \overline{Dm-1} \cdot \overline{Dm-2}$ (2-bit shift) C = Dm (1-bit shift) or C = Dm-1 (2-bit shift)
SHAR	—	↓	↓	0	↓	N = Rm Z = $\overline{Rm} \cdot \overline{Rm-1} \cdot \dots \cdot \overline{R0}$ C = D0 (1-bit shift) or C = D1 (2-bit shift)
SHLL	—	↓	↓	0	↓	N = Rm Z = $\overline{Rm} \cdot \overline{Rm-1} \cdot \dots \cdot \overline{R0}$ C = Dm (1-bit shift) or C = Dm-1 (2-bit shift)
SHLR	—	0	↓	0	↓	N = Rm Z = $\overline{Rm} \cdot \overline{Rm-1} \cdot \dots \cdot \overline{R0}$ C = D0 (1-bit shift) or C = D1 (2-bit shift)
SLEEP	—	—	—	—	—	
STC	—	—	—	—	—	
STM	—	—	—	—	—	
STMAC						Cannot be used in the LSI

Instruction	H	N	Z	V	C	Definition
SUB	↑	↑	↑	↑	↑	$H = S_{m-4} \cdot \overline{D_{m-4}} + \overline{D_{m-4}} \cdot R_{m-4} + S_{m-4} \cdot R_{m-4}$ $N = R_m$ $Z = \overline{R_m} \cdot \overline{R_{m-1}} \cdot \dots \cdot \overline{R_0}$ $V = \overline{S_m} \cdot D_m \cdot \overline{R_m} + S_m \cdot \overline{D_m} \cdot R_m$ $C = S_m \cdot \overline{D_m} + \overline{D_m} \cdot R_m + S_m \cdot R_m$
SUBS	—	—	—	—	—	
SUBX	↑	↑	↑	↑	↑	$H = S_{m-4} \cdot \overline{D_{m-4}} + \overline{D_{m-4}} \cdot R_{m-4} + S_{m-4} \cdot R_{m-4}$ $N = R_m$ $Z = Z' \cdot \overline{R_m} \cdot \dots \cdot \overline{R_0}$ $V = \overline{S_m} \cdot D_m \cdot \overline{R_m} + S_m \cdot \overline{D_m} \cdot R_m$ $C = S_m \cdot \overline{D_m} + \overline{D_m} \cdot R_m + S_m \cdot R_m$
TAS*	—	↑	↑	0	—	$N = D_m$ $Z = \overline{D_m} \cdot \overline{D_{m-1}} \cdot \dots \cdot \overline{D_0}$
TRAPA	—	—	—	—	—	
XOR	—	↑	↑	0	—	$N = R_m$ $Z = \overline{R_m} \cdot \overline{R_{m-1}} \cdot \dots \cdot \overline{R_0}$
XORC	↑	↑	↑	↑	↑	Stores the corresponding bits of the result. No flags change when the operand is EXR.

Note: \* Only register ER0, ER1, ER4, or ER5 should be used when using the TAS instruction.

# Appendix B Internal I/O Register

## B.1 Addresses

Address	Register Name	Bit 7	Bit 6	Bit 5	Bit 4	Bit 3	Bit 2	Bit 1	Bit 0	Module Name	Data Bus Width	
H'EBC0 to H'EFBF	MRA	SM1	SM0	DM1	DM0	MD1	MD0	DTS	Sz	DTC	16/32* bits	
	SAR	_____										
	MRB	CHNE	DISEL	—	—	—	—	—	—			
	DAR	_____										
	CRA	_____										
	CRB	_____										
H'FDB4	SCRX	—	—	—	—	FLSHE	—	—	—	FLASH	8 bits	
H'FDD0	SMR3	C/ $\bar{A}$	CHR	PE	O/ $\bar{E}$	STOP	MP	CKS1	CKS0	SCI3	8 bits	
H'FDD1	BRR3											
H'FDD2	SCR3	TIE	RIE	TE	RE	MPIE	TEIE	CKE1	CKE0			
H'FDD3	TDR3											
H'FDD4	SSR3	TDRE	RDRF	ORER	FER	PER	TEND	MPB	MPBT			
H'FDD5	RDR3											
H'FDD6	SCMR3	—	—	—	—	SDIR	—	—	—			
H'FDE4	SBYCR	SSBY	STS2	STS1	STS0	OPE	—	—	—	Power-down state	8 bits	
H'FDE5	SYSCR	—	—	INTM1	INTM0	NMIEG	—	—	RAME	MCU	8 bits	
H'FDE6	SCKCR	PSTOP	—	—	—	—	SCK2	SCK1	SCK0	Clock pulse generator	8 bits	
H'FDE7	MDCR	—	—	—	—	—	MDS2	MDS1	MSD0	MCU	8 bits	
H'FDE8	MSTPCRA	MSTPA7	MSTPA6	MSTPA5	MSTPA4	MSTPA3	MSTPA2	MSTPA1	MSTPA0	Power-down state	8 bits	
H'FDE9	MSTPCRB	MSTPB7	MSTPB6	MSTPB5	MSTPB4	MSTPB3	MSTPB2	MSTPB1	MSTPB0			
H'FDEA	MSTPCRC	MSTPC7	MSTPC6	MSTPC5	MSTPC4	MSTPC3	MSTPC2	MSTPC1	MSTPC0			
H'FDEB	PFCCR	—	—	BUZZE	—	AE3	AE2	AE1	AE0	Bus controller	8 bits	
H'FDEC	LPWRCR	DTON	LSON	NESEL	SUBSTP	RFCUT	—	STC1	STC0	Power-down state	8 bits	
H'FE00	BARA	—	—	—	—	—	—	—	—	PBC	16 bits	
H'FE01		BAA23	BAA22	BAA21	BAA20	BAA19	BAA18	BAA17	BAA16			
H'FE02		BAA15	BAA14	BAA13	BAA12	BAA11	BAA10	BAA9	BAA8			
H'FE03		BAA7	BAA6	BAA5	BAA4	BAA3	BAA2	BAA1	BAA0			

Register										Module	Data
Address Name	Bit 7	Bit 6	Bit 5	Bit 4	Bit 3	Bit 2	Bit 1	Bit 0	Name	Bus Width	
H'FE04	BARB	—	—	—	—	—	—	—	PBC	16 bits	
H'FE05		BAB23	BAB22	BAB21	BAB20	BAB19	BAB18	BAB17	BAB16		
H'FE06		BAB15	BAB14	BAB13	BAB12	BAB11	BAB10	BAB9	BAB8		
H'FE07		BAB7	BAB6	BAB5	BAB4	BAB3	BAB2	BAB1	BAB0		
H'FE08	BCRA	CMFA	CDA	BAMRA2	BAMRA1	BAMRA0	CSELA1	CSELA0	BIEA	8 bits	
H'FE09	BCRB	CMFB	CDB	BAMRB2	BAMRB1	BAMRB0	CSELB1	CSELB0	BIEB		
H'FE12	ISCRH	IRQ7SCB	IRQ7SCA	IRQ6SCB	IRQ6SCA	IRQ5SCB	IRQ5SCA	IRQ4SCB	IRQ4SCA	Interrupt controller	
H'FE13	ISCL	IRQ3SCB	IRQ3SCA	IRQ2SCB	IRQ2SCA	IRQ1SCB	IRQ1SCA	IRQ0SCB	IRQ0SCA		
H'FE14	IER	IRQ7E	IRQ6E	IRQ5E	IRQ4E	IRQ3E	IRQ2E	IRQ1E	IRQ0E		
H'FE15	ISR	IRQ7F	IRQ6F	IRQ5F	IRQ4F	IRQ3F	IRQ2F	IRQ1F	IRQ0F		
H'FE16	DT CER	DTCE7	DTCE6	DTCE5	DTCE4	DTCE3	DTCE2	DTCE1	DTCE0	DTC	8 bits
H'FE1A, H'FE1E											
H'FE1F	DTVECR	SWDTE	DTVEC6	DTVEC5	DTVEC4	DTVEC3	DTVEC2	DTVEC1	DTVEC0		
H'FE30	P1DDR	—	P16DDR	—	P14DDR	P13DDR	P12DDR	P11DDR	P10DDR	Port	8 bits
H'FE32	P3DDR	—	P36DDR	P35DDR	P34DDR	P33DDR	P32DDR	P31DDR	P30DDR		
H'FE36	P7DDR	P77DDR	—	P75DDR	P74DDR	—	—	—	—		
H'FE39	PADDR	—	—	—	—	PA3DDR	PA2DDR	PA1DDR	PA0DDR		
H'FE3A	PBDDR	PB7DDR	PB6DDR	PB5DDR	PB4DDR	PB3DDR	PB2DDR	PB1DDR	PB0DDR		
H'FE3B	PCDDR	PC7DDR	PC6DDR	PC5DDR	PC4DDR	PC3DDR	PC2DDR	PC1DDR	PC0DDR		
H'FE3C	PDDDR	PD7DDR	PD6DDR	PD5DDR	PD4DDR	PD3DDR	PD2DDR	PD1DDR	PD0DDR		
H'FE3D	PEDDR	PE7DDR	PE6DDR	PE5DDR	PE4DDR	PE3DDR	PE2DDR	PE1DDR	PE0DDR		
H'FE3E	PFDDR	PF7DDR	PF6DDR	PF5DDR	PF4DDR	PF3DDR	PF2DDR	PF1DDR	PF0DDR		
H'FE3F	PGDDR	—	—	—	PG4DDR	PG3DDR	PG2DDR	PG1DDR	—		
H'FE40	PAPCR	—	—	—	—	PA3PCR	PA2PCR	PA1PCR	PA0PCR		
H'FE41	PBPCR	PB7PCR	PB6PCR	PB5PCR	PB4PCR	PB3PCR	PB2PCR	PB1PCR	PB0PCR		
H'FE42	PCPCR	PC7PCR	PC6PCR	PC5PCR	PC4PCR	PC3PCR	PC2PCR	PC1PCR	PC0PCR		
H'FE43	PDPCR	PD7PCR	PD6PCR	PD5PCR	PD4PCR	PD3PCR	PD2PCR	PD1PCR	PD0PCR		
H'FE44	PEPCR	PE7PCR	PE6PCR	PE5PCR	PE4PCR	PE3PCR	PE2PCR	PE1PCR	PE0PCR		
H'FE46	P3ODR	—	—	P35ODR	P34ODR	P33ODR	P32ODR	P31ODR	P30ODR		
H'FE47	PAODR	—	—	—	—	PA3ODR	PA2ODR	PA1ODR	PA0ODR		
H'FEB0	TSTR	—	—	—	—	—	CST2	CST1	CST0	TPU	8 bits
H'FEB1	TSYR	—	—	—	—	—	SYNC2	SYNC1	SYNC0		
H'FEC0	IPRA	—	IPR6	IPR5	IPR4	—	IPR2	IPR1	IPR0	Interrupt controller	
H'FEC1	IPRB	—	IPR6	IPR5	IPR4	—	IPR2	IPR1	IPR0		
H'FEC2	IPRC	—	IPR6	IPR5	IPR4	—	IPR2	IPR1	IPR0		
H'FEC3	IPRD	—	IPR6	IPR5	IPR4	—	—	—	—		



Register										Module	Data		
Address	Name	Bit 7	Bit 6	Bit 5	Bit 4	Bit 3	Bit 2	Bit 1	Bit 0	Name	Bus Width		
H'FEC4	IPRE	—	IPR6	IPR5	IPR4	—	IPR2	IPR1	IPR0	Interrupt controller	8 bits		
H'FEC5	IPRF	—	IPR6	IPR5	IPR4	—	IPR2	IPR1	IPR0				
H'FEC6	IPRG	—	IPR6	IPR5	IPR4	—	—	—	—				
H'FEC8	IPRI	—	IPR6	IPR5	IPR4	—	IPR2	IPR1	IPR0				
H'FEC9	IPRJ	—	—	—	—	—	IPR2	IPR1	IPR0				
H'FECA	IPRK	—	IPR6	IPR5	IPR4	—	—	—	—				
H'FECE	IPRO	—	IPR6	IPR5	IPR4	—	—	—	—				
H'FED0	ABWCR	ABW7	ABW6	ABW5	ABW4	ABW3	ABW2	ABW1	ABW0	Bus controller	8 bits		
H'FED1	ASTCR	AST7	AST6	AST5	AST4	AST3	AST2	AST1	AST0				
H'FED2	WCRH	W71	W70	W61	W60	W51	W50	W41	W40				
H'FED3	WCRL	W31	W30	W21	W20	W11	W10	W01	W00				
H'FED4	BCRH	ICIS1	ICIS0	BRSTRM	BRSTS1	BRSTS0	—	—	—				
H'FED5	BCRL	BRLE	—	—	—	—	—	—	WAITE				
H'FEDB	RAMER	—	—	—	—	RAMS	—	RAM1	RAM0	FLASH	8 bits		
H'FF00	P1DR	—	P16DR	—	P14DR	P13DR	P12DR	P11DR	P10DR	Port	8 bits		
H'FF02	P3DR	—	P36DR	P35DR	P34DR	P33DR	P32DR	P31DR	P30DR				
H'FF06	P7DR	P77DR	—	P75DR	P74DR	—	—	—	—				
H'FF09	PADR	—	—	—	—	PA3DR	PA2DR	PA1DR	PA0DR				
H'FF0A	PBDR	PB7DR	PB6DR	PB5DR	PB4DR	PB3DR	PB2DR	PB1DR	PB0DR				
H'FF0B	PCDR	PC7DR	PC6DR	PC5DR	PC4DR	PC3DR	PC2DR	PC1DR	PC0DR				
H'FF0C	PDDR	PD7DR	PD6DR	PD5DR	PD4DR	PD3DR	PD2DR	PD1DR	PD0DR				
H'FF0D	PEDR	PE7DR	PE6DR	PE5DR	PE4DR	PE3DR	PE2DR	PE1DR	PE0DR				
H'FF0E	PFDR	PF7DR	PF6DR	PF5DR	PF4DR	PF3DR	PF2DR	PF1DR	PF0DR				
H'FF0F	PGDR	—	—	—	PG4DR	PG3DR	PG2DR	PG1DR	—				
H'FF10	TCR0	CCLR2	CCLR1	CCLR0	CKEG1	CKEG0	TPSC2	TPSC1	TPSC0			TPU0	8 bits
H'FF11	TMDR0	—	—	BFB	BFA	MD3	MD2	MD1	MD0				
H'FF12	TIOR0H	IOB3	IOB2	IOB1	IOB0	IOA3	IOA2	IOA1	IOA0				
H'FF13	TIOR0L	IOD3	IOD2	IOD1	IOD0	IOC3	IOC2	IOC1	IOC0				
H'FF14	TIER0	TTGE	—	—	TCIEV	TGIED	TGIEC	TGIEB	TGIEA				
H'FF15	TSR0	—	—	—	TCFV	TGFD	TGFC	TGFB	TGFA				
H'FF16	TCNT0										16 bits		
H'FF17													
H'FF18	TGR0A												
H'FF19													
H'FF1A	TGR0B												
H'FF1B													
H'FF1C	TGR0C												
H'FF1D													

Address	Register									Module Name	Data Bus Width
	Name	Bit 7	Bit 6	Bit 5	Bit 4	Bit 3	Bit 2	Bit 1	Bit 0		
H'FF1E	TGR0D									TPU0	16 bits
H'FF1F											
H'FF20	TCR1	—	CCLR1	CCLR0	CKEG1	CKEG0	TPSC2	TPSC1	TPSC0	TPU1	8 bits
H'FF21	TMDR1	—	—	—	—	MD3	MD2	MD1	MD0		
H'FF22	TIOR1	IOB3	IOB2	IOB1	IOB0	IOA3	IOA2	IOA1	IOA0		
H'FF24	TIER1	TTGE	—	TCIEU	TCIEV	—	—	TGIEB	TGIEA		
H'FF25	TSR1	TCFD	—	TCFU	TCFV	—	—	TGFB	TGFA		
H'FF26	TCNT1										16 bits
H'FF27											
H'FF28	TGR1A										
H'FF29											
H'FF2A	TGR1B										
H'FF2B											
H'FF30	TCR2	—	CCLR1	CCLR0	CKEG1	CKEG0	TPSC2	TPSC1	TPSC0	TPU2	8 bits
H'FF31	TMDR2	—	—	—	—	MD3	MD2	MD1	MD0		
H'FF32	TIOR2	IOB3	IOB2	IOB1	IOB0	IOA3	IOA2	IOA1	IOA0		
H'FF34	TIER2	TTGE	—	TCIEU	TCIEV	—	—	TGIEB	TGIEA		
H'FF35	TSR2	TCFD	—	TCFU	TCFV	—	—	TGFB	TGFA		
H'FF36	TCNT2										16 bits
H'FF37											
H'FF38	TGR2A										
H'FF39											
H'FF3A	TGR2B										
H'FF3B											
H'FF68	TCR0	CMIEB	CMIEA	OVIE	CCLR1	CCLR0	CKS2	CKS1	CKS0	TMR0,TMR1	8 bits
H'FF69	TCR1	CMIEB	CMIEA	OVIE	CCLR1	CCLR0	CKS2	CKS1	CKS0		
H'FF6A	TCSR0	CMFB	CMFA	OVF	ADTE	—	—	—	—		
H'FF6B	TCSR1	CMFB	CMFA	OVF	—	—	—	—	—		
H'FF6C	TCORA0										8/16 bits
H'FF6D	TCORA1										
H'FF6E	TCORB0										
H'FF6F	TCORB1										
H'FF70	TCNT0										
H'FF71	TCNT1										
H'FF74	TCSR0	OVF	WT/IT	TME	—	—	CKS2	CKS1	CKS0	Watchdog timer 0	16 bits
H'FF75 (read)	TCNT0										
H'FF77 (read)	RSTCSR	WOVF	RSTE	—	—	—	—	—	—		

Register										Module Name	Data Bus Width		
Address	Name	Bit 7	Bit 6	Bit 5	Bit 4	Bit 3	Bit 2	Bit 1	Bit 0				
H'FF78	SMR0	C/ $\bar{A}$	CHR	PE	O/ $\bar{E}$	STOP	MP	CKS1	CKS0	SCI0	8 bits		
H'FF79	BRR0												
H'FF7A	SCR0	TIE	RIE	TE	RE	MPIE	TEIE	CKE1	CKE0				
H'FF7B	TDR0												
H'FF7C	SSR0	TDRE	RDRF	ORER	FER	PER	TEND	MPB	MPBT				
H'FF7D	RDR0												
H'FF7E	SCMR0	—	—	—	—	SDIR	—	—	—				
H'FF80	SMR1	C/ $\bar{A}$	CHR	PE	O/ $\bar{E}$	STOP	MP	CKS1	CKS0	SCI1	8 bits		
H'FF81	BRR1												
H'FF82	SCR1	TIE	RIE	TE	RE	MPIE	TEIE	CKE1	CKE0				
H'FF83	TDR1												
H'FF84	SSR1	TDRE	RDRF	ORER	FER	PER	TEND	MPB	MPBT				
H'FF85	RDR1												
H'FF86	SCMR1	—	—	—	—	SDIR	—	—	—				
H'FF90	ADDRAH	AD9	AD8	AD7	AD6	AD5	AD4	AD3	AD2	A/D converter	8 bits		
H'FF91	ADDRAL	AD1	AD0	—	—	—	—	—	—				
H'FF92	ADDRBH	AD9	AD8	AD7	AD6	AD5	AD4	AD3	AD2				
H'FF93	ADDRBL	AD1	AD0	—	—	—	—	—	—				
H'FF94	ADDRCH	AD9	AD8	AD7	AD6	AD5	AD4	AD3	AD2				
H'FF95	ADDRCL	AD1	AD0	—	—	—	—	—	—				
H'FF96	ADDRDH	AD9	AD8	AD7	AD6	AD5	AD4	AD3	AD2				
H'FF97	ADDRDL	AD1	AD0	—	—	—	—	—	—				
H'FF98	ADCSR	ADF	ADIE	ADST	SCAN	—	CH2	CH1	CH0				
H'FF99	ADCR	TRGS1	TRGS0	—	—	CKS1	CKS0	—	—				
H'FFA2	TCSR1	OVF	WT/ $\bar{IT}$	TME	PSS	RST/ $\bar{NMI}$	CKS2	CKS1	CKS0			Watchdog timer 1	16 bits
H'FFA3	TCNT1 (read)												
H'FFA8	FLMCR1	FWE	SWE1	ESU1	PSU1	EV1	PV1	E1	P1			FLASH	8 bits
H'FFA9	FLMCR2	FLER	—	—	—	—	—	—	—				
H'FFAA	EBR1	EB7	EB6	EB5	EB4	EB3	EB2	EB1	EB0				
H'FFAB	EBR2	—	—	—	—	—	—	EB9	EB8				
H'FFAC	FLPWCR	PDWND	—	—	—	—	—	—	—				
H'FFB0	PORT1	—	P16	—	P14	P13	P12	P11	P10	Port	8 bits		
H'FFB2	PORT3	—	—	P35	P34	P33	P32	P31	P30				
H'FFB3	PORT4	P47	P46	P45	P44	P43	P42	P41	P40				
H'FFB6	PORT7	—	P76	—	—	—	—	—	—				
H'FFB9	PORTA	—	—	—	—	PA3	PA2	PA1	PA0				

Register										Module	Data
Address	Name	Bit 7	Bit 6	Bit 5	Bit 4	Bit 3	Bit 2	Bit 1	Bit 0	Name	Bus Width
H'FFBA	PORTB	PB7	PB6	PB5	PB4	PB3	PB2	PB1	PB0	Port	8 bits
H'FFBB	PORTC	PC7	PC6	PC5	PC4	PC3	PC2	PC1	PC0		
H'FFBC	PORTD	PD7	PD6	PD5	PD4	PD3	PD2	PD1	PD0		
H'FFBD	PORTE	PE7	PE6	PE5	PE4	PE3	PE2	PE1	PE0		
H'FFBE	PORTF	PF7	PF6	PF5	PF4	PF3	PF2	PF1	PF0		
H'FFBF	PORTG	—	—	—	PG4	PG3	PG2	PG1	PG0		

Note: \* Located in on-chip RAM. The bus width is 32 bits when the DTC accesses this area as register information, and 16 bits otherwise.

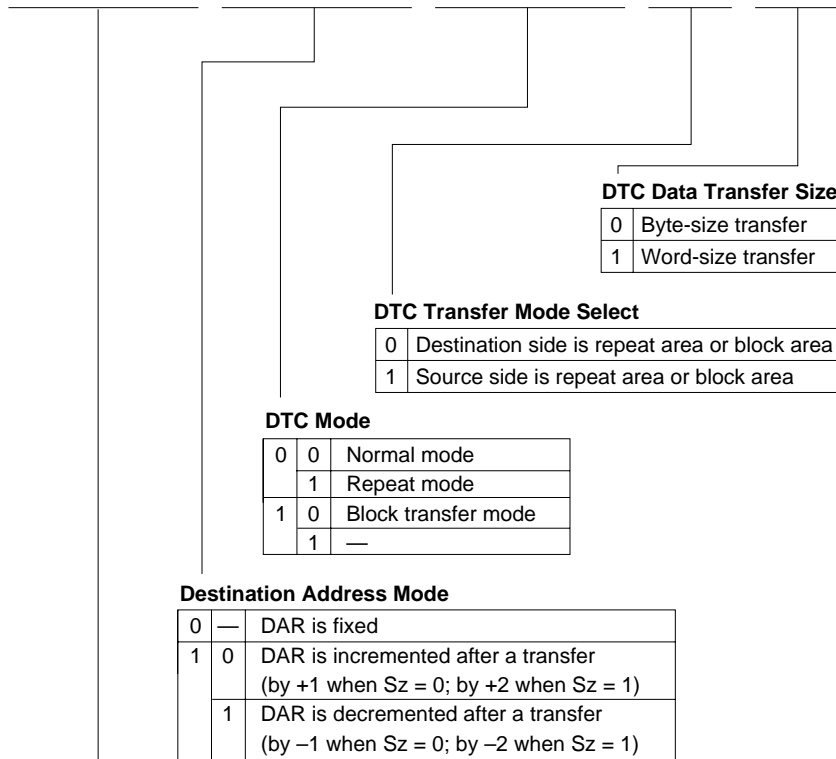
## B.2 Functions

### MRA—DTC Mode Register A

H'EBC0 to H'EFBF

DTC

Bit	:	7	6	5	4	3	2	1	0
		SM1	SM0	DM1	DM0	MD1	MD0	DTS	Sz
Initial value	:	Unde- fined	Unde- fined	Unde- fined	Unde- fined	Unde- fined	Unde- fined	Unde- fined	Unde- fined
R/W	:	—	—	—	—	—	—	—	—



#### Source Address Mode

0	—	SAR is fixed
1	0	SAR is incremented after a transfer (by +1 when Sz = 0; by +2 when Sz = 1)
	1	SAR is decremented after a transfer (by -1 when Sz = 0; by -2 when Sz = 1)

Bit	:	7	6	5	4	3	2	1	0
		CHNE	DISEL	—	—	—	—	—	—
Initial value:		Unde- fined	Unde- fined	Unde- fined	Unde- fined	Unde- fined	Unde- fined	Unde- fined	Unde- fined
R/W	:	—	—	—	—	—	—	—	—

**Reserved**  
Only 0 should be written to these bits

**DTC Interrupt Select**

0	After a data transfer ends, the CPU interrupt is disabled unless the transfer counter is 0
1	After a data transfer ends, the CPU interrupt is enabled

**DTC Chain Transfer Enable**

0	End of DTC data transfer
1	DTC chain transfer

**SAR—DTC Source Address Register**

H'EBC0 to H'EFBF

DTC

Bit	:	23	22	21	20	19	---	4	3	2	1	0
							---					
Initial value:		Unde- fined	Unde- fined	Unde- fined	Unde- fined	Unde- fined	---	Unde- fined	Unde- fined	Unde- fined	Unde- fined	Unde- fined
R/W	:	—	—	—	—	—	---	—	—	—	—	—

Specifies transfer data source address

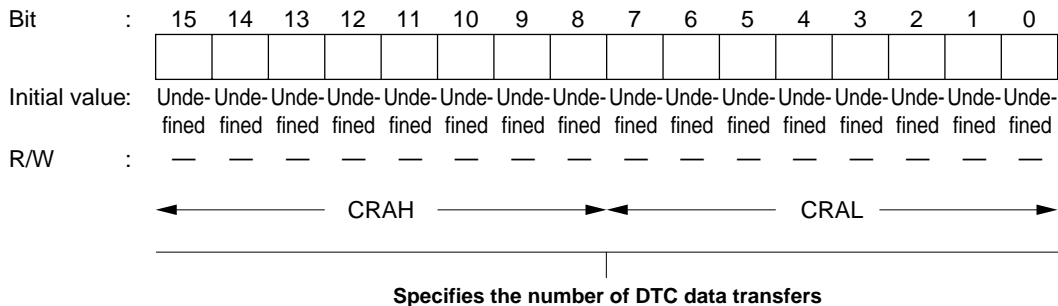
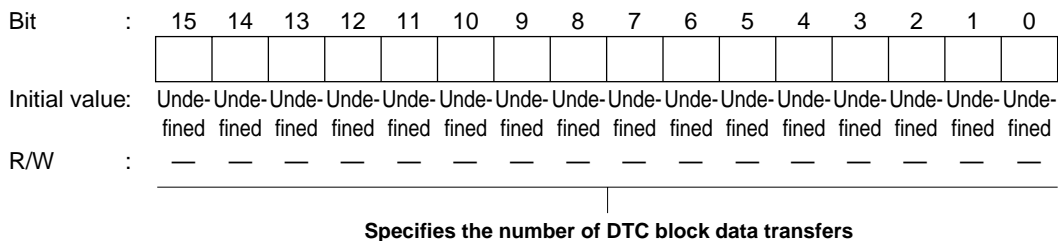
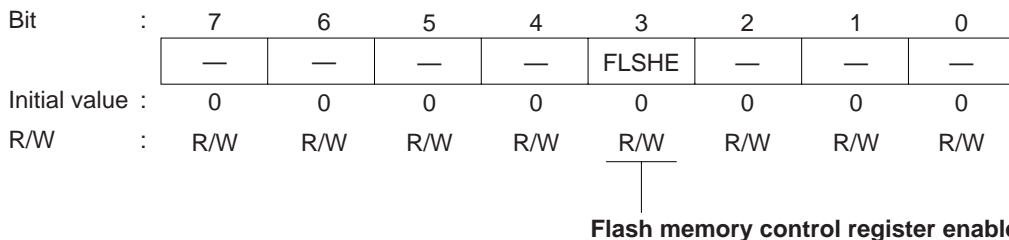
**DAR—DTC Destination Address Register**

H'EBC0 to H'EFBF

DTC

Bit	:	23	22	21	20	19	---	4	3	2	1	0
							---					
Initial value	:	Unde- fined	Unde- fined	Unde- fined	Unde- fined	Unde- fined	---	Unde- fined	Unde- fined	Unde- fined	Unde- fined	Unde- fined
R/W	:	—	—	—	—	—	---	—	—	—	—	—

Specifies transfer data destination address

**CRA—DTC Transfer Count Register A****H'EBC0 to H'EFBF****DTC****CRB—DTC Transfer Count Register B****H'EBC0 to H'EFBF****DTC****SCRX—Serial Control Register X****H'FDB4****FLASH**

Bit	:	7	6	5	4	3	2	1	0
		C/ $\bar{A}$	CHR	PE	O/ $\bar{E}$	STOP	MP	CKS1	CKS0
Initial value :		0	0	0	0	0	0	0	0
R/W	:	R/W	R/W	R/W	R/W	R/W	R/W	R/W	R/W

**Clock Select**

0	0	$\emptyset$ clock
	1	$\emptyset/4$ clock
1	0	$\emptyset/16$ clock
	1	$\emptyset/64$ clock

**Multiprocessor Mode**

0	Multiprocessor function disabled
1	Multiprocessor format selected

**Stop Bit Length**

0	1 stop bit
1	2 stop bits

**Parity Mode**

0	Even parity*1
1	Odd parity*2

Notes: \*1 When even parity is set, parity bit addition is performed in transmission so that the total number of 1-bits in the transmit character plus the parity bit is even. In reception, a check is performed to see if the total number of 1-bits in the receive character plus the parity bit is even.

\*2 When odd parity is set, parity bit addition is performed in transmission so that the total number of 1-bits in the transmit character plus the parity bit is odd. In reception, a check is performed to see if the total number of 1-bits in the receive character plus the parity bit is odd.

**Parity Enable**

0	Parity bit addition and checking disabled
1	Parity bit addition and checking enabled*

Note: \* When the PE bit is set to 1, an even or odd parity bit is added to transmit data according to the even or odd parity mode selection by the O/ $\bar{E}$  bit, and the parity bit in receive data is checked to see if it matches the even or odd mode selected by the O/ $\bar{E}$  bit.

**Character Length**

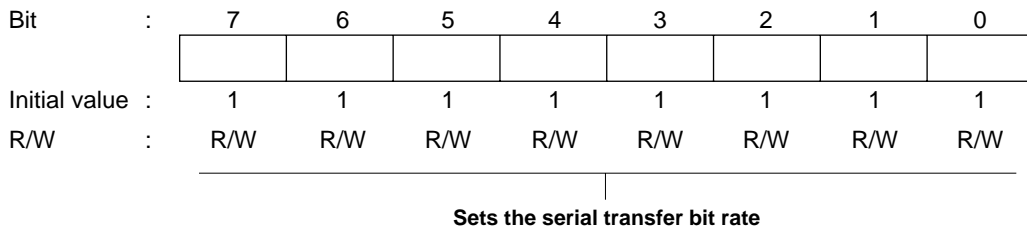
0	8-bit data
1	7-bit data*

Note: \* When 7-bit data is selected, the MSB (bit 7) of TDR is not transmitted, and it is not possible to choose between LSB-first or MSB-first transfer.

**Selects Asynchronous Mode or Clocked Synchronous Mode**

0	Asynchronous mode
1	Clocked synchronous mode





Note: For details, see section 13.2.8, Bit Rate Register (BRR).

Bit	:	7	6	5	4	3	2	1	0
		TIE	RIE	TE	RE	MPIE	TEIE	CKE1	CKE0
Initial value :		0	0	0	0	0	0	0	0
R/W :		R/W	R/W	R/W	R/W	R/W	R/W	R/W	R/W

**Clock Enable**

0	0	Asynchronous mode	Internal clock/SCK pin functions as I/O port
		Clocked synchronous mode	Internal clock/SCK pin functions as serial clock output
1	0	Asynchronous mode	Internal clock/SCK pin functions as clock output*1
		Clocked synchronous mode	Internal clock/SCK pin functions as serial clock output
1	*	Setting prohibited*2	

**Transmit End Interrupt Enable**

0	Transmit end interrupt (TEI) request disabled*3
1	Transmit end interrupt (TEI) request enabled*3

**Multiprocessor Interrupt Enable**

0	Multiprocessor interrupts disabled [Clearing conditions] • When the MPIE bit is cleared to 0 • When MPB= 1 data is received
1	Multiprocessor interrupts enabled*4 Receive interrupt (RXI) requests, receive error interrupt (ERI) requests, and setting of the RDRF, FER, and ORER flags in SSR are disabled until data with the multiprocessor bit set to 1 is received.

**Receive Enable**

0	Reception disabled*5
1	Reception enabled*6

**Transmit Enable**

0	Transmission disabled*7
1	Transmission enabled*8

**Receive Interrupt Enable**

0	Receive data full interrupt (RXI) request and receive error interrupt (ERI) request disabled*9
1	Receive data full interrupt (RXI) request and receive error interrupt (ERI) request enabled

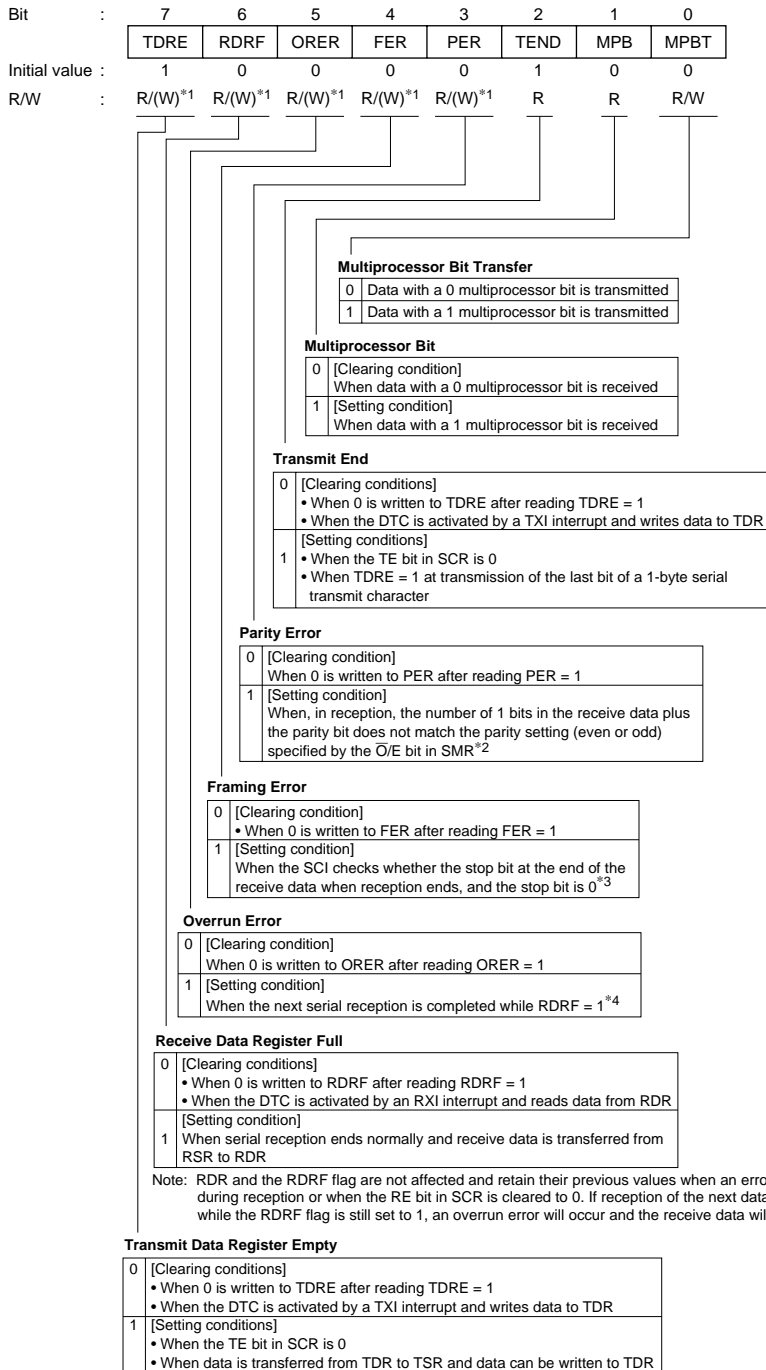
**Transmit Interrupt Enable**

0	Transmit data empty interrupt (TXI) requests disabled
1	Transmit data empty interrupt (TXI) requests enabled

Note: TXI cancellation can be performed by reading 1 from the TDRE flag, then clearing it to 0, or by clearing the TIE bit to 0.

- Notes:
- \*1 Outputs a clock of the same frequency as the bit rate.
  - \*2 The CKE1 bit of SCR3 should be cleared to 0.
  - \*3 TEI cancellation can be performed by reading 1 from the TDRE flag in SSR, then clearing it to 0 and clearing the TEND flag to 0, or by clearing the TEIE bit to 0.
  - \*4 When receive data including MPB = 0 is received, receive data transfer from RSR to RDR, receive error detection, and setting of the RDRF, FER, and ORER flags in SSR, is not performed. When receive data including MPB = 1 is received, the MPB bit in SSR is set to 1, the MPIE bit is cleared to 0 automatically, and generation of RXI and ERI interrupts (when the TIE and RIE bits in SCR are set to 1) and FER and ORER flag setting is enabled.
  - \*5 Clearing the RE bit to 0 does not affect the RDRF, FER, PER, and ORER flags, which retain their states.
  - \*6 Serial reception is started in this state when a start bit is detected in asynchronous mode or serial clock input is detected in clocked synchronous mode. SMR setting must be performed to decide the receive format before setting the RE bit to 1.
  - \*7 The TDRE flag in SSR is fixed at 1.
  - \*8 In this state, serial transmission is started when transmit data is written to TDR and the TDRE flag in SSR is cleared to 0. SMR setting must be performed to decide the transmit format before setting the TE bit to 1.
  - \*9 RXI and ERI cancellation can be performed by reading 1 from the RDRF flag, or the FER, PER, or ORER flag, then clearing the flag to 0, or by clearing the RIE bit to 0.

<b>TDR3—Transmit Data Register 3</b>				<b>H'FDD3</b>				<b>SCI3</b>	
Bit	:	7	6	5	4	3	2	1	0
Initial value	:	1	1	1	1	1	1	1	1
R/W	:	R/W	R/W	R/W	R/W	R/W	R/W	R/W	R/W
<div style="border-top: 1px solid black; width: 100%; margin-top: 5px;"></div> <b>Stores data for serial transmission</b>									

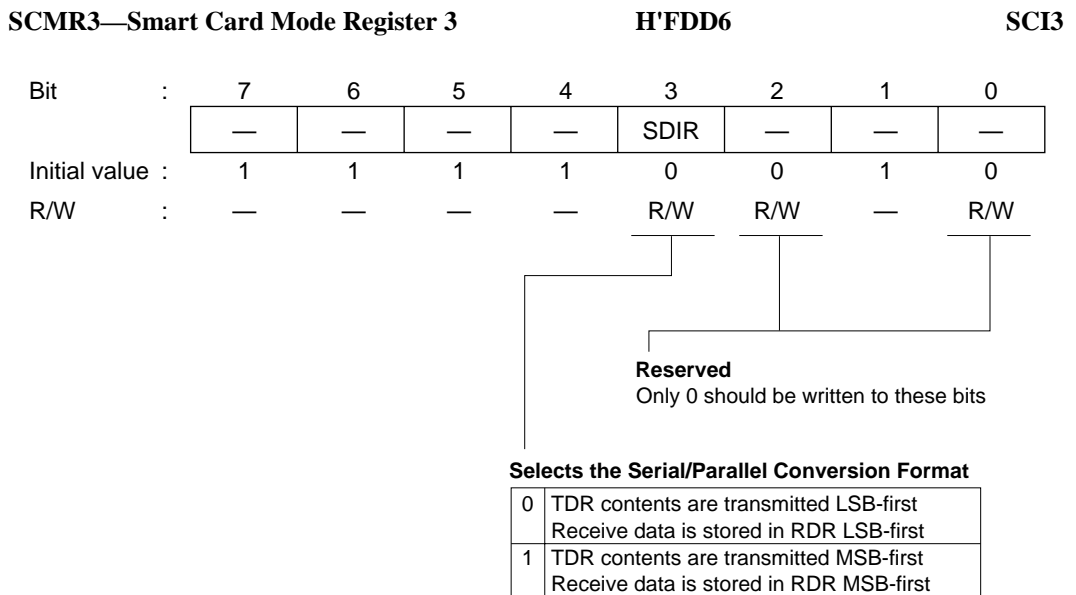


Notes: \*1 Only 0 can be written, to clear the flag.

\*2 If a parity error occurs, the receive data is transferred to RDR but the RDRF flag is not set. Also, subsequent serial reception cannot be continued while the PER flag is set to 1. In clocked synchronous mode, serial transmission cannot be continued, either.

\*3 In 2-stop-bit mode, only the first stop bit is checked for a value of 1; the second stop bit is not checked. If a framing error occurs, the receive data is transferred to RDR but the RDRF flag is not set. Serial reception cannot be continued while the FER flag is set to 1. In clocked synchronous mode, serial transmission cannot be continued, either.

\*4 The receive data prior to the overrun error is retained in RDR, and the data received subsequently is lost. Serial reception cannot be continued while the ORER flag is set to 1. In clocked synchronous mode, serial transmission cannot be continued either.



Bit	:	7	6	5	4	3	2	1	0
		SSBY	STS2	STS1	STS0	OPE	—	—	—
Initial value	:	0	0	0	0	1	0	0	0
R/W	:	R/W	R/W	R/W	R/W	R/W	—	—	—

**Output Port Enable**

0	In software standby mode and watch mode, and in a direct transition, address bus and bus control signals are high-impedance
1	In software standby mode and watch mode, and in a direct transition, address bus and bus control signals retain their output state

**Standby Timer Select**

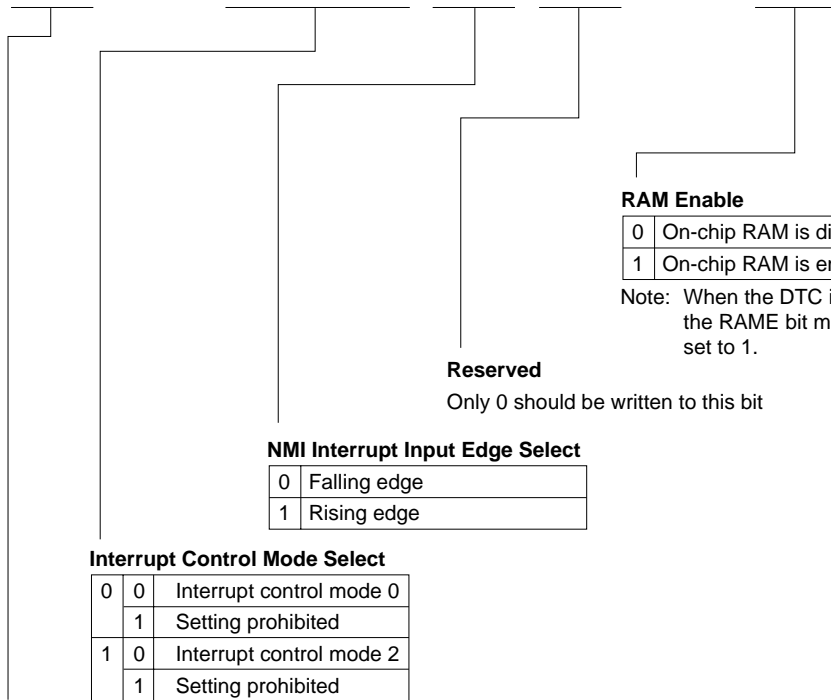
0	0	0	Standby time = 8192 states
		1	Standby time = 16384 states
	1	0	Standby time = 32768 states
		1	Standby time = 65536 states
1	0	0	Standby time = 131072 states
		1	Standby time = 262144 states
	1	0	Reserved
		1	Standby time = 16 states*

Note: \* Not used on the F-ZTAT version.

**Software Standby**

0	Transition to sleep mode after execution of SLEEP instruction in high-speed mode or medium-speed mode
	Transition to subsleep mode after execution of SLEEP instruction in subactive mode
1	Transition to software standby mode, subactive mode, or watch mode after execution of SLEEP instruction in high-speed mode or medium-speed mode
	Transition to watch mode or high-speed mode after execution of SLEEP instruction in subactive mode

Bit	:	7	6	5	4	3	2	1	0
		—	—	INTM1	INTM0	NMIEG	—	—	RAME
Initial value:		0	0	0	0	0	0	0	1
R/W	:	R/W	—	R/W	R/W	R/W	R/W	—	R/W

**Reserved**

Only 0 should be written to this bit

Bit	:	7	6	5	4	3	2	1	0
		PSTOP	—	—	—	—	SCK2	SCK1	SCK0
Initial value:		0	0	0	0	0	0	0	0
R/W	:	R/W	R/W	R/W	R/W	R/W	R/W	R/W	R/W

**Reserved**  
Only 0 should be written to these bits

**Bus Master Clock Select**

0	0	0	Bus master is in high-speed mode
		1	Medium-speed clock is $\phi/2$
	1	0	Medium-speed clock is $\phi/4$
		1	Medium-speed clock is $\phi/8$
1	0	0	Medium-speed clock is $\phi/16$
		1	Medium-speed clock is $\phi/32$
	1	—	—

 **$\phi$  Clock Output Control**

PSTOP	High-Speed Mode, Medium-Speed Mode, Subactive Mode	Sleep Mode, Subsleep Mode	Software Standby Mode, Watch Mode, Direct Transition	Hardware Standby Mode
0	$\phi$ output	$\phi$ output	Fixed high	High impedance
1	Fixed high	Fixed high	Fixed high	High impedance

**MDCR—Mode Control Register**

Bit	:	7	6	5	4	3	2	1	0
		—	—	—	—	—	MDS2	MDS1	MDS0
Initial value:		1	0	0	0	0	—*	—*	—*
R/W	:	—	—	—	—	—	R	R	R

**Current mode pin operating mode**

Note: \* Determined by pins MD2 to MD0.



**MSTPCRA—Module Stop Control Register A**  
**MSTPCRB—Module Stop Control Register B**  
**MSTPCRC—Module Stop Control Register C**

**H'FDE8**  
**H'FDE9**  
**H'FDEA**

**Power-Down State**

**MSTPCRA**

Bit	:	7	6	5	4	3	2	1	0
		MSTPA7	MSTPA6	MSTPA5	MSTPA4	MSTPA3	MSTPA2	MSTPA1	MSTPA0
Initial value	:	0	0	1	1	1	1	1	1
R/W	:	R/W	R/W	R/W	R/W	R/W	R/W	R/W	R/W

**MSTPCRB**

Bit	:	7	6	5	4	3	2	1	0
		MSTPB7	MSTPB6	MSTPB5	MSTPB4	MSTPB3	MSTPB2	MSTPB1	MSTPB0
Initial value	:	1	1	1	1	1	1	1	1
R/W	:	R/W	R/W	R/W	R/W	R/W	R/W	R/W	R/W

**MSTPCRC**

Bit	:	7	6	5	4	3	2	1	0
		MSTPC7	MSTPC6	MSTPC5	MSTPC4	MSTPC3	MSTPC2	MSTPC1	MSTPC0
Initial value	:	1	1	1	1	1	1	1	1
R/W	:	R/W	R/W	R/W	R/W	R/W	R/W	R/W	R/W

**Specifies Module Stop Mode**

0	Module stop mode is cleared
1	Module stop mode is set

Bit	:	7	6	5	4	3	2	1	0
		—	—	BUZZE	—	AE3	AE2	AE1	AE0

Modes 4 and 5

Initial value : 0 0 0 0 1 1 0 1

Modes 6 and 7

Initial value : 0 0 0 0 0 0 0 0

R/W : R/W R/W R/W R/W R/W R/W R/W R/W

**Reserved**  
Only 0 should be written  
to these bits

**Reserved**  
Only 0 should be written  
to this bit

#### Address Output Enable

0	0	0	0	A8 to A23 output disabled	(Initial value)*1	
			1	A8 output enabled; A9 to A23 output disabled		
		1	0	A8, A9 output enabled; A10 to A23 output disabled		
			1	A8 to A10 output enabled; A11 to A23 output disabled		
	1	0	0	A8 to A11 output enabled; A12 to A23 output disabled		
			1	A8 to A12 output enabled; A13 to A23 output disabled		
		1	0	A8 to A13 output enabled; A14 to A23 output disabled		
			1	A8 to A14 output enabled; A15 to A23 output disabled		
	1	0	0	A8 to A15 output enabled; A16 to A23 output disabled		
				1	A8 to A16 output enabled; A17 to A23 output disabled	
			1	0	A8 to A17 output enabled; A18 to A23 output disabled	
				1	A8 to A18 output enabled; A19 to A23 output disabled	
		1	0	0	A8 to A19 output enabled; A20 to A23 output disabled	
				1	A8 to A20 output enabled; A21 to A23 output disabled	(Initial value)*2
			1	0	A8 to A21 output enabled; A22, A23 output disabled	
				1	A8 to A23 output enabled	

Notes: \*1 In expanded mode with ROM, bits AE3 to AE0 are initialized to B'0000.

In expanded mode with ROM, address pins A0 to A7 are made address outputs by setting the corresponding DDR bits to 1.

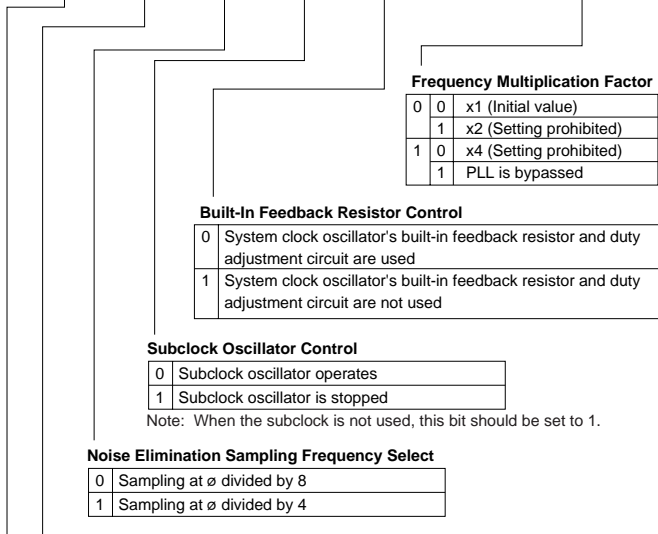
\*2 In ROMless expanded mode, bits AE3 to AE0 are initialized to B'1101.

In ROMless expanded mode, address pins A0 to A7 are always address outputs.

#### BUZZ Output Enable

0	Functions as PF1 I/O pin
1	Functions as BUZZ output pin

Bit	:	7	6	5	4	3	2	1	0
		DTON	LSON	NESEL	SUBSTP	RFCUT	—	STC1	STC0
Initial value	:	0	0	0	0	0	0	0	0
R/W	:	R/W	R/W	R/W	R/W	R/W	R/W	R/W	R/W



**Low-Speed On Flag**

0	When a SLEEP instruction is executed in high-speed mode or medium-speed mode, a transition is made to sleep mode, software standby mode, or watch mode* When a SLEEP instruction is executed in subactive mode, a transition is made to watch mode, or directly to high-speed mode After watch mode is cleared, a transition is made to high-speed mode
1	When a SLEEP instruction is executed in high-speed mode a transition is made to watch mode or subactive mode* When a SLEEP instruction is executed in subactive mode, a transition is made to subsleep mode or watch mode After watch mode is cleared, a transition is made to subactive mode

**Direct-Transfer On Flag**

0	When a SLEEP instruction is executed in high-speed mode or medium-speed mode, a transition is made to sleep mode, software standby mode, or watch mode* When a SLEEP instruction is executed in subactive mode, a transition is made to subsleep mode or watch mode
1	When a SLEEP instruction is executed in high-speed mode or medium-speed mode, a transition is made directly to subactive mode*, or a transition is made to sleep mode or software standby mode When a SLEEP instruction is executed in subactive mode, a transition is made directly to high-speed mode, or a transition is made to subsleep mode

Note: \* When a transition is made to watch mode or subactive mode, high-speed mode must be set.

**BARA—Break Address Register A****H'FE00****PBC****BARB—Break Address Register B****H'FE04**

Bit	:	31	...	24	23	22	21	20	19	18	17	16	...	7	6	5	4	3	2	1	0
		—	...	—	BAA	BAA	BAA	BAA	BAA	BAA	BAA	BAA	...	BAA	BAA	BAA	BAA	BAA	BAA	BAA	BAA
					23	22	21	20	19	18	17	16		7	6	5	4	3	2	1	0

Initial value: Unde- ... Unde- 0 0 0 0 0 0 0 0 0 0 ... 0 0 0 0 0 0 0 0 0 0  
 R/W : — ... — R/W R/W R/W R/W R/W R/W R/W R/W R/W ... R/W R/W R/W R/W R/W R/W R/W R/W R/W R/W

Bit	:	31	...	24	23	22	21	20	19	18	17	16	...	7	6	5	4	3	2	1	0
		—	...	—	BAB	BAB	BAB	BAB	BAB	BAB	BAB	BAB	...	BAB	BAB	BAB	BAB	BAB	BAB	BAB	BAB
					23	22	21	20	19	18	17	16		7	6	5	4	3	2	1	0

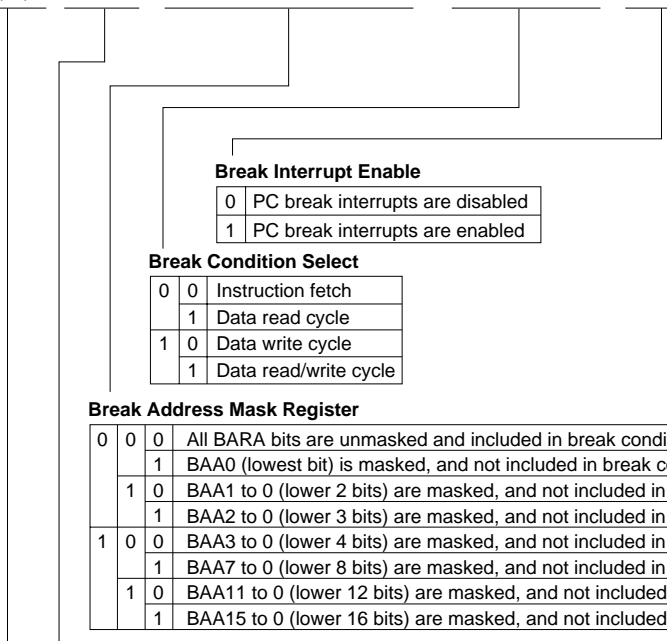
Initial value: Unde- ... Unde- 0 0 0 0 0 0 0 0 0 0 ... 0 0 0 0 0 0 0 0 0 0  
 R/W : — ... — R/W R/W R/W R/W R/W R/W R/W R/W R/W ... R/W R/W R/W R/W R/W R/W R/W R/W R/W R/W

┆  
**These bits hold the channel A or B PC break address**

Bit	:	7	6	5	4	3	2	1	0
		CMFA	CDA	BAMRA2	BAMRA1	BAMRA0	CSELA1	CSELA0	BIEA

Initial value : 0 0 0 0 0 0 0 0 0

R/W : R/(W)\* R/W R/W R/W R/W R/W R/W R/W



**Break Interrupt Enable**

0	PC break interrupts are disabled
1	PC break interrupts are enabled

**Break Condition Select**

0	0	Instruction fetch
	1	Data read cycle
1	0	Data write cycle
	1	Data read/write cycle

**Break Address Mask Register**

0	0	0	All BAA bits are unmasked and included in break conditions
		1	BAA0 (lowest bit) is masked, and not included in break conditions
1	0	0	BAA1 to 0 (lower 2 bits) are masked, and not included in break conditions
		1	BAA2 to 0 (lower 3 bits) are masked, and not included in break conditions
1	0	0	BAA3 to 0 (lower 4 bits) are masked, and not included in break conditions
		1	BAA7 to 0 (lower 8 bits) are masked, and not included in break conditions
	1	0	BAA11 to 0 (lower 12 bits) are masked, and not included in break conditions
		1	BAA15 to 0 (lower 16 bits) are masked, and not included in break conditions

**CPU Cycle/DTC Cycle Select**

0	PC break is performed when CPU is bus master
1	PC break is performed when CPU or DTC is bus master

**Condition Match Flag A**

0	[Clearing condition] When 0 is written to CMFA after reading CMFA = 1
1	[Setting condition] When a condition set for channel A is satisfied

Note: \* Only 0 can be written, to clear the flag.

Bit	:	7	6	5	4	3	2	1	0
		CMFB	CDB	BAMRB2	BAMRB1	BAMRB0	CSELB1	CSELB0	BIEB

Initial value : 0 0 0 0 0 0 0 0 0

R/W : R/W R/W R/W R/W R/W R/W R/W R/W

The bit configuration is the same as for BCRA

**ISCRH**

Bit	:	15	14	13	12	11	10	9	8
		IRQ7SCB	IRQ7SCA	IRQ6SCB	IRQ6SCA	IRQ5SCB	IRQ5SCA	IRQ4SCB	IRQ4SCA
Initial value:		0	0	0	0	0	0	0	0
R/W	:	R/W	R/W	R/W	R/W	R/W	R/W	R/W	R/W

|  
**IRQ7 to IRQ4 Sense Control**

**ISCRL**

Bit	:	7	6	5	4	3	2	1	0
		IRQ3SCB	IRQ3SCA	IRQ2SCB	IRQ2SCA	IRQ1SCB	IRQ1SCA	IRQ0SCB	IRQ0SCA
Initial value:		0	0	0	0	0	0	0	0
R/W	:	R/W	R/W	R/W	R/W	R/W	R/W	R/W	R/W

|  
**IRQ3 to IRQ0 Sense Control**

IRQnSCB	IRQnSCA	Interrupt Request Generation
0	0	$\overline{\text{IRQn}}$ input low level
	1	Falling edge of $\overline{\text{IRQn}}$ input
1	0	Rising edge of $\overline{\text{IRQn}}$ input
	1	Both falling and rising edges of $\overline{\text{IRQn}}$ input

(n= 7 to 0)

**IER—IRQ Enable Register****H'FE14****Interrupt Controller**

Bit	:	7	6	5	4	3	2	1	0
		IRQ7E	IRQ6E	IRQ5E	IRQ4E	IRQ3E	IRQ2E	IRQ1E	IRQ0E
Initial value	:	0	0	0	0	0	0	0	0
R/W	:	R/W	R/W	R/W	R/W	R/W	R/W	R/W	R/W

**IRQn Enable**

0	IRQn interrupts disabled
1	IRQn interrupts enabled

(n= 7 to 0)

**ISR—IRQ Status Register****H'FE15****Interrupt Controller**

Bit	:	7	6	5	4	3	2	1	0
		IRQ7F	IRQ6F	IRQ5F	IRQ4F	IRQ3F	IRQ2F	IRQ1F	IRQ0F
Initial value:		0	0	0	0	0	0	0	0
R/W	:	R/(W)*	R/(W)*	R/(W)*	R/(W)*	R/(W)*	R/(W)*	R/(W)*	R/(W)*

**Indicates the status of IRQ7 to IRQ0 interrupt requests**

Note: \* Only 0 can be written, to clear the flag.

Bit	:	7	6	5	4	3	2	1	0
		DTCE7	DTCE6	DTCE5	DTCE4	DTCE3	DTCE2	DTCE1	DTCE0
Initial value:		0	0	0	0	0	0	0	0
R/W	:	R/W	R/W	R/W	R/W	R/W	R/W	R/W	R/W

**DTC Activation Enable**

0	DTC activation by this interrupt is disabled [Clearing conditions] • When the DISEL bit is 1 and the data transfer has ended • When the specified number of transfers have ended
1	DTC activation by this interrupt is enabled [Holding condition] When the DISEL bit is 0 and the specified number of transfers have not ended

**Correspondence between Interrupt Sources and DTCER**

Register	Bit							
	7	6	5	4	3	2	1	0
DTCERA	IRQ0	IRQ1	IRQ2	IRQ3	IRQ4	IRQ5	IRQ6	IRQ7
DTCERB	—	ADI	TGI0A	TGI0B	TGI0C	TGI0D	TGI1A	TGI1B
DTCERC	TGI2A	TGI2B	—	—	—	—	—	—
DTCERD	—	—	—	—	CMIA0	CMIB0	CMIA1	CMIB1
DTCERE	—	—	—	—	RXI0	TXI0	RXI1	TXI1
DTCERI	RXI3	TXI3	—	—	—	—	—	—



Bit	:	7	6	5	4	3	2	1	0
		SWDTE	DTVEC6	DTVEC5	DTVEC4	DTVEC3	DTVEC2	DTVEC1	DTVEC0
Initial value:		0	0	0	0	0	0	0	0
R/W	:	R/(W)*1	R/(W)*2	R/(W)*2	R/(W)*2	R/(W)*2	R/(W)*2	R/(W)*2	R/(W)*2

Sets vector number for DTC software activation

**DTC Software Activation Enable**

0	DTC software activation is disabled [Clearing conditions] <ul style="list-style-type: none"> <li>When the DISEL bit is 0 and the specified number of transfers have not ended</li> <li>When 0 is written to the DISEL bit after a software-activated data transfer end interrupt (SWDTEND) request has been sent to the CPU</li> </ul>
1	DTC software activation is enabled [Holding conditions] <ul style="list-style-type: none"> <li>When the DISEL bit is 1 and data transfer has ended</li> <li>When the specified number of transfers have ended</li> <li>During data transfer due to software activation</li> </ul>

Notes: \*1 Only 1 can be written to the SWDTE bit.

\*2 Bits DTVEC6 to DTVEC0 can be written to when SWDTE = 0.

**P1DDR—Port 1 Data Direction Register****H'FE30****Port 1**

Bit	:	7	6	5	4	3	2	1	0
		—	P16DDR	—	P14DDR	P13DDR	P12DDR	P11DDR	P10DDR
Initial value	:	Undefined	0	Undefined	0	0	0	0	0
R/W	:	W	W	W	W	W	W	W	W

Specify input or output for the pins of port 1

**P3DDR—Port 3 Data Direction Register****H'FE32****Port 3**

Bit	:	7	6	5	4	3	2	1	0
		—	P36DDR	P35DDR	P34DDR	P33DDR	P32DDR	P31DDR	P30DDR
Initial value	:	Undefined	0	0	0	0	0	0	0
R/W	:	—	W	W	W	W	W	W	W

Specify input or output for the pins of port 3

**P7DDR—Port 7 Data Direction Register****H'FE36****Port 7**

Bit	:	7	6	5	4	3	2	1	0
		P77DDR	—	P75DDR	P74DDR	—	—	—	—
Initial value	:	0	Undefined	0	0	Undefined	Undefined	Undefined	Undefined
R/W	:	W	W	W	W	W	W	W	W

Specify input or output for the pins of port 7

**PADDR—Port A Data Direction Register****H'FE39****Port A**

Bit	:	7	6	5	4	3	2	1	0
		—	—	—	—	PA3DDR	PA2DDR	PA1DDR	PA0DDR
Initial value	:	Undefined	Undefined	Undefined	Undefined	0	0	0	0
R/W	:	—	—	—	—	W	W	W	W

Specify input or output for the pins of port A

**PBDDR—Port B Data Direction Register****H'FE3A****Port B**

Bit	:	7	6	5	4	3	2	1	0
		PB7DDR	PB6DDR	PB5DDR	PB4DDR	PB3DDR	PB2DDR	PB1DDR	PB0DDR
Initial value	:	0	0	0	0	0	0	0	0
R/W	:	W	W	W	W	W	W	W	W

Specify input or output for the pins of port B

**PCDDR—Port C Data Direction Register****H'FE3B****Port C**

Bit	:	7	6	5	4	3	2	1	0
		PC7DDR	PC6DDR	PC5DDR	PC4DDR	PC3DDR	PC2DDR	PC1DDR	PC0DDR
Initial value	:	0	0	0	0	0	0	0	0
R/W	:	W	W	W	W	W	W	W	W

---

Specify input or output for the pins of port C

**PDDDR—Port D Data Direction Register****H'FE3C****Port D**

Bit	:	7	6	5	4	3	2	1	0
		PD7DDR	PD6DDR	PD5DDR	PD4DDR	PD3DDR	PD2DDR	PD1DDR	PD0DDR
Initial value	:	0	0	0	0	0	0	0	0
R/W	:	W	W	W	W	W	W	W	W

---

Specify input or output for the pins of port D

**PEDDR—Port E Data Direction Register****H'FE3D****Port E**

Bit	:	7	6	5	4	3	2	1	0
		PE7DDR	PE6DDR	PE5DDR	PE4DDR	PE3DDR	PE2DDR	PE1DDR	PE0DDR
Initial value	:	0	0	0	0	0	0	0	0
R/W	:	W	W	W	W	W	W	W	W

---

Specify input or output for the pins of port E

**PFDDR—Port F Data Direction Register****H'FE3E****Port F**

Bit	:	7	6	5	4	3	2	1	0
		PF7DDR	PF6DDR	PF5DDR	PF4DDR	PF3DDR	PF2DDR	PF1DDR	PF0DDR

Modes 4 to 6

Initial value : 1 0 0 0 0 0 0 0 0

R/W : W W W W W W W W W

Mode 7

Initial value : 0 0 0 0 0 0 0 0 0

R/W : W W W W W W W W W

Specify input or output for the pins of port F

**PGDDR—Port G Data Direction Register****H'FE3F****Port G**

Bit	:	7	6	5	4	3	2	1	0
		—	—	—	PG4DDR	PG3DDR	PG2DDR	PG1DDR	—

Modes 4 and 5

Initial value : Undefined Undefined Undefined 1 0 0 0 Undefined

R/W : — — — W W W W W

Modes 6 and 7

Initial value : Undefined Undefined Undefined 0 0 0 0 Undefined

R/W : — — — W W W W W

Specify input or output for the pins of port G

**PAPCR—Port A MOS Pull-Up Control Register****H'FE40****Port A**

Bit	:	7	6	5	4	3	2	1	0
		—	—	—	—	PA3PCR	PA2PCR	PA1PCR	PA0PCR
Initial value	:	Undefined	Undefined	Undefined	Undefined	0	0	0	0
R/W	:	—	—	—	—	R/W	R/W	R/W	R/W

Controls the MOS input pull-up function incorporated into port A on a bit-by-bit basis

**PBPCR—Port B MOS Pull-Up Control Register****H'FE41****Port B**

Bit	:	7	6	5	4	3	2	1	0
		PB7PCR	PB6PCR	PB5PCR	PB4PCR	PB3PCR	PB2PCR	PB1PCR	PB0PCR
Initial value	:	0	0	0	0	0	0	0	0
R/W	:	R/W	R/W	R/W	R/W	R/W	R/W	R/W	R/W

Controls the MOS input pull-up function incorporated into port B on a bit-by-bit basis

**PCPCR—Port C MOS Pull-Up Control Register****H'FE42****Port C**

Bit	:	7	6	5	4	3	2	1	0
		PC7PCR	PC6PCR	PC5PCR	PC4PCR	PC3PCR	PC2PCR	PC1PCR	PC0PCR
Initial value	:	0	0	0	0	0	0	0	0
R/W	:	R/W	R/W	R/W	R/W	R/W	R/W	R/W	R/W

Controls the MOS input pull-up function incorporated into port C on a bit-by-bit basis

**PDPCR—Port D MOS Pull-Up Control Register****H'FE43****Port D**

Bit	:	7	6	5	4	3	2	1	0
		PD7PCR	PD6PCR	PD5PCR	PD4PCR	PD3PCR	PD2PCR	PD1PCR	PD0PCR
Initial value	:	0	0	0	0	0	0	0	0
R/W	:	R/W	R/W	R/W	R/W	R/W	R/W	R/W	R/W

Controls the MOS input pull-up function incorporated into port D on a bit-by-bit basis

**PEPCR—Port E MOS Pull-Up Control Register****H'FE44****Port E**

Bit	:	7	6	5	4	3	2	1	0
		PE7PCR	PE6PCR	PE5PCR	PE4PCR	PE3PCR	PE2PCR	PE1PCR	PE0PCR
Initial value	:	0	0	0	0	0	0	0	0
R/W	:	R/W	R/W	R/W	R/W	R/W	R/W	R/W	R/W

Controls the MOS input pull-up function incorporated into port E on a bit-by-bit basis

**P3ODR—Port 3 Open-Drain Control Register****H'FE46****Port 3**

Bit	:	7	6	5	4	3	2	1	0
		—	—	P35ODR	P34ODR	P33ODR	P32ODR	P31ODR	P30ODR
Initial value	:	Undefined	Undefined	0	0	0	0	0	0
R/W	:	—	R/W	R/W	R/W	R/W	R/W	R/W	R/W

Controls the PMOS on/off status for each port 3 pin (P35 to P30)

**PAODR—Port A Open-Drain Control Register****H'FE47****Port A**

Bit	:	7	6	5	4	3	2	1	0
		—	—	—	—	PA3ODR	PA2ODR	PA1ODR	PA0ODR
Initial value	:	Undefined	Undefined	Undefined	Undefined	0	0	0	0
R/W	:	—	—	—	—	R/W	R/W	R/W	R/W

Controls the PMOS on/off status for each port A pin (PA3 to PA0)

Bit	:	7	6	5	4	3	2	1	0
		—	—	—	—	—	CST2	CST1	CST0
Initial value	:	0	0	0	0	0	0	0	0
R/W	:	—	—	—	—	—	R/W	R/W	R/W

## Counter Start

0	TCNTn count operation is stopped
1	TCNTn performs count operation

(n= 2 to 0)

Note: If 0 is written to the CST bit during operation with the TIOC pin designated for output, the counter stops but the TIOC pin output compare output level is retained. If TIOR is written to when the CST bit is cleared to 0, the pin output level will be changed to the set initial output value.

Bit	:	7	6	5	4	3	2	1	0
		—	—	—	—	—	SYNC2	SYNC1	SYNC0
Initial value	:	0	0	0	0	0	0	0	0
R/W	:	—	—	—	—	—	R/W	R/W	R/W

## Timer Synchro

0	TCNTn operates independently (TCNT presetting/clearing is unrelated to other channels)
1	TCNTn performs synchronous operation TCNT synchronous presetting/synchronous clearing is possible

(n= 2 to 0)

- Notes:
1. To set synchronous operation, the SYNC bits for at least two channels must be set to 1.
  2. To set synchronous clearing, in addition to the SYNC bit, the TCNT clearing source must also be set by means of bits CCLR2 to CCLR0 in TCR.

<b>IPRA—Interrupt Priority Register A</b>	<b>H'FEC0</b>	<b>Interrupt Controller</b>
<b>IPRB—Interrupt Priority Register B</b>	<b>H'FEC1</b>	
<b>IPRC—Interrupt Priority Register C</b>	<b>H'FEC2</b>	
<b>IPRD—Interrupt Priority Register D</b>	<b>H'FEC3</b>	
<b>IPRE—Interrupt Priority Register E</b>	<b>H'FEC4</b>	
<b>IPRF—Interrupt Priority Register F</b>	<b>H'FEC5</b>	
<b>IPRG—Interrupt Priority Register G</b>	<b>H'FEC6</b>	
<b>IPRI—Interrupt Priority Register I</b>	<b>H'FEC8</b>	
<b>IPRJ—Interrupt Priority Register J</b>	<b>H'FEC9</b>	
<b>IPRK—Interrupt Priority Register K</b>	<b>H'FECA</b>	
<b>IPRO—Interrupt Priority Register O</b>	<b>H'FECE</b>	

Bit	:	7	6	5	4	3	2	1	0
		—	IPR6	IPR5	IPR4	—	IPR2	IPR1	IPR0
Initial value	:	0	1	1	1	0	1	1	1
R/W	:	—	R/W	R/W	R/W	—	R/W	R/W	R/W

Set priority (levels 7 to 0) for interrupt sources

Correspondence between Interrupt Sources and IPR Settings

Register	Bits	
	6 to 4	2 to 0
IPRA	IRQ0	IRQ1
IPRB	IRQ2, IRQ3	IRQ4, IRQ5
IPRC	IRQ6, IRQ7	DTC
IPRD	Watchdog timer 0	—*
IPRE	PC break	A/D converter, watchdog timer 1
IPRF	TPU channel 0	TPU channel 1
IPRG	TPU channel 2	—*
IPRI	8-bit timer channel 0	8-bit timer channel 1
IPRJ	—*	SCI channel 0
IPRK	SCI channel 1	—*
IPRO	SCI channel 3	—*

Note: \* Reserved bits. These bits cannot be modified and are always read as 1.



**ABWCR—Bus Width Control Register****H'FED0****Bus Controller**

Bit	:	7	6	5	4	3	2	1	0
		ABW7	ABW6	ABW5	ABW4	ABW3	ABW2	ABW1	ABW0

Modes 5 to 7

Initial value : 1 1 1 1 1 1 1 1

R/W : R/W R/W R/W R/W R/W R/W R/W R/W

Mode 4

Initial value : 0 0 0 0 0 0 0 0

R/W : R/W R/W R/W R/W R/W R/W R/W R/W

**Area 7 to 0 Bus Width Control**

0	Area n is designated for 16-bit access
1	Area n is designated for 8-bit access

(n= 7 to 0)

**ASTCR—Access State Control Register****H'FED1****Bus Controller**

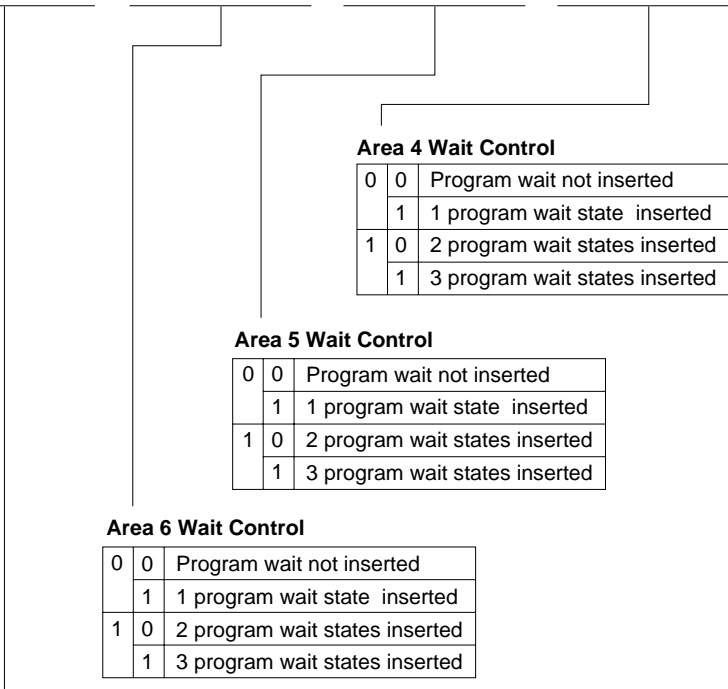
Bit	:	7	6	5	4	3	2	1	0
		AST7	AST6	AST5	AST4	AST3	AST2	AST1	AST0
Initial value :		1	1	1	1	1	1	1	1
R/W :		R/W	R/W	R/W	R/W	R/W	R/W	R/W	R/W

**Area 7 to 0 Access State Control**

0	Area n is designated for 2-state access Wait state insertion in area n external space is disabled
1	Area n is designated for 3-state access Wait state insertion in area n external space is enabled

(n= 7 to 0)

Bit	:	7	6	5	4	3	2	1	0
		W71	W70	W61	W60	W51	W50	W41	W40
Initial value	:	1	1	1	1	1	1	1	1
R/W	:	R/W	R/W	R/W	R/W	R/W	R/W	R/W	R/W



**Area 4 Wait Control**

0	0	Program wait not inserted
	1	1 program wait state inserted
1	0	2 program wait states inserted
	1	3 program wait states inserted

**Area 5 Wait Control**

0	0	Program wait not inserted
	1	1 program wait state inserted
1	0	2 program wait states inserted
	1	3 program wait states inserted

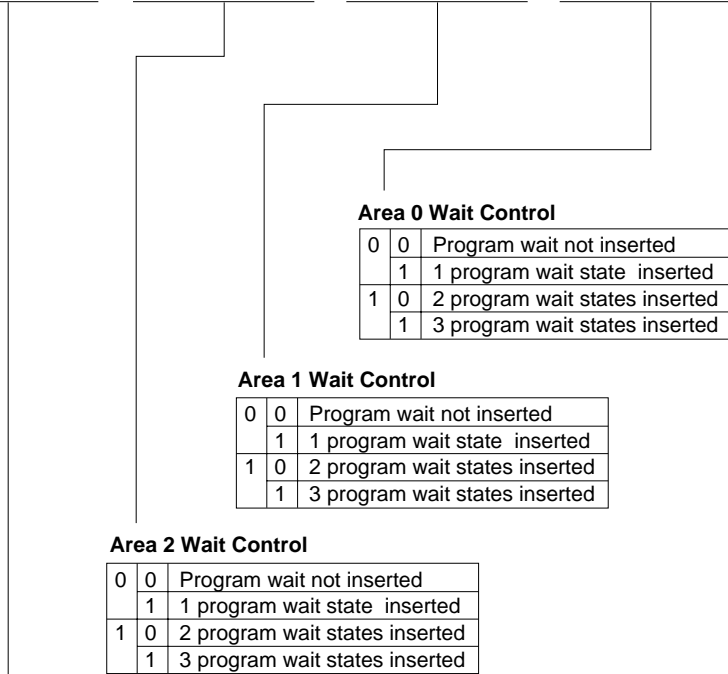
**Area 6 Wait Control**

0	0	Program wait not inserted
	1	1 program wait state inserted
1	0	2 program wait states inserted
	1	3 program wait states inserted

**Area 7 Wait Control**

0	0	Program wait not inserted
	1	1 program wait state inserted
1	0	2 program wait states inserted
	1	3 program wait states inserted

Bit	:	7	6	5	4	3	2	1	0
		W31	W30	W21	W20	W11	W10	W01	W00
Initial value	:	1	1	1	1	1	1	1	1
R/W	:	R/W	R/W	R/W	R/W	R/W	R/W	R/W	R/W



**Area 0 Wait Control**

0	0	Program wait not inserted
0	1	1 program wait state inserted
1	0	2 program wait states inserted
1	1	3 program wait states inserted

**Area 1 Wait Control**

0	0	Program wait not inserted
0	1	1 program wait state inserted
1	0	2 program wait states inserted
1	1	3 program wait states inserted

**Area 2 Wait Control**

0	0	Program wait not inserted
0	1	1 program wait state inserted
1	0	2 program wait states inserted
1	1	3 program wait states inserted

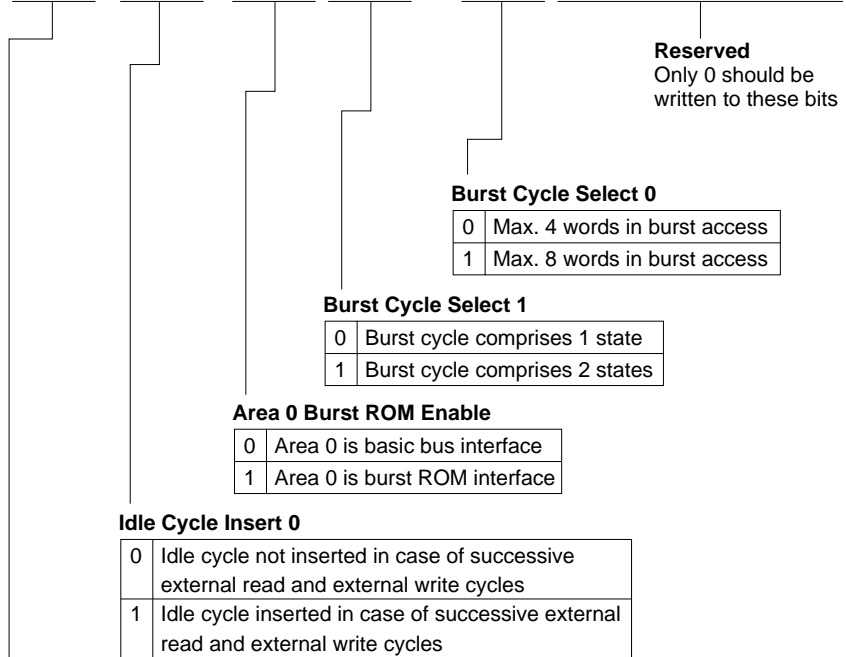
**Area 3 Wait Control**

0	0	Program wait not inserted
0	1	1 program wait state inserted
1	0	2 program wait states inserted
1	1	3 program wait states inserted

Bit	:	7	6	5	4	3	2	1	0
		ICIS1	ICIS0	BRSTRM	BRSTS1	BRSTS0	—	—	—

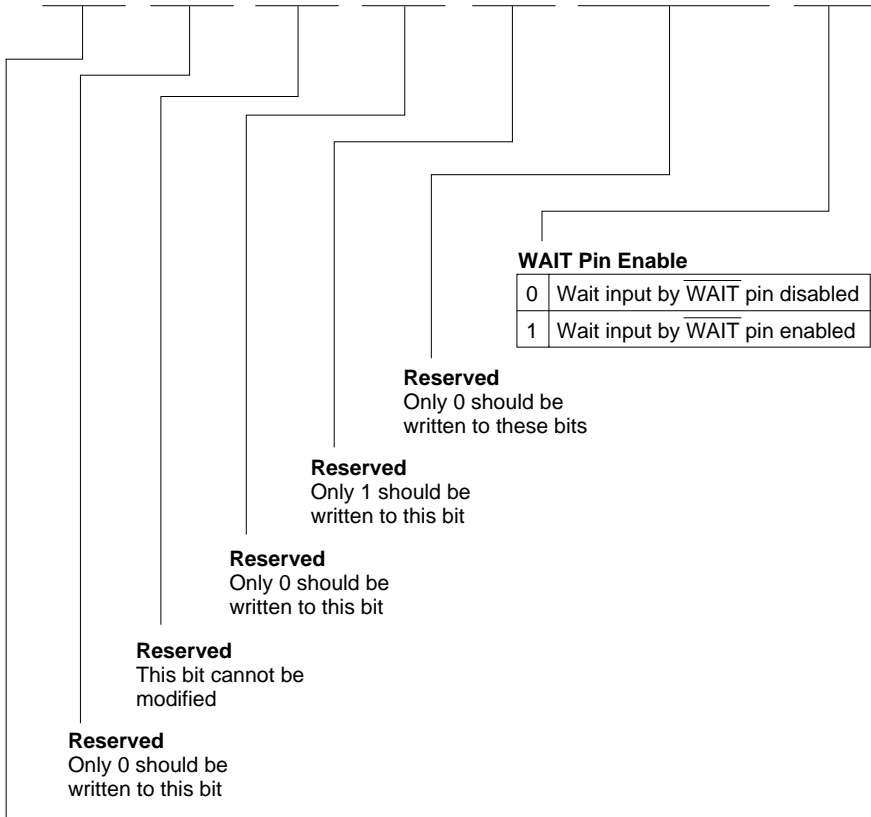
Initial value : 1 1 0 1 0 0 0 0 0

R/W : R/W R/W R/W R/W R/W R/W R/W R/W

**Idle Cycle Insert 1**

0	Idle cycle not inserted in case of successive external read cycles in different areas
1	Idle cycle inserted in case of successive external read cycles in different areas

Bit	:	7	6	5	4	3	2	1	0
		BRLE	—	—	—	—	—	—	WAITE
Initial value	:	0	0	0	0	1	0	0	0
R/W	:	R/W	R/W	—	R/W	R/W	R/W	R/W	R/W



**WAIT Pin Enable**

0	Wait input by $\overline{\text{WAIT}}$ pin disabled
1	Wait input by $\overline{\text{WAIT}}$ pin enabled

**Reserved**  
Only 0 should be written to these bits

**Reserved**  
Only 1 should be written to this bit

**Reserved**  
Only 0 should be written to this bit

**Reserved**  
This bit cannot be modified

**Reserved**  
Only 0 should be written to this bit

**Bus Release Enable**

0	External bus release is disabled
1	External bus release is enabled

**RAMER—RAM Emulation Register****H'FEDB****ROM**

Bit	:	7	6	5	4	3	2	1	0
		—	—	—	—	RAMS	—	RAM1	RAM0
Initial value	:	0	0	0	0	0	0	0	0
R/W	:	R	R	R	R/W	R/W	R/W	R/W	R/W

**Flash Memory Area Selection**

**Reserved**  
Only 0 should be written to these bits

**RAM Select**

0	Emulation not selected Program/erase-protection of all flash memory blocks is disabled
1	Emulation selected Program/erase-protection of all flash memory blocks is enabled

**P1DR—Port 1 Data Register****H'FF00****Port 1**

Bit	:	7	6	5	4	3	2	1	0
		—	P16DR	—	P14DR	P13DR	P12DR	P11DR	P10DR
Initial value	:	Undefined	0	Undefined	0	0	0	0	0
R/W	:	R/W	R/W	R/W	R/W	R/W	R/W	R/W	R/W

Stores output data for the port 1 pins (P16, P14 to P10)

**P3DR—Port 3 Data Register****H'FF02****Port 3**

Bit	:	7	6	5	4	3	2	1	0
		—	P36DR	P35DR	P34DR	P33DR	P32DR	P31DR	P30DR
Initial value	:	Undefined	0	0	0	0	0	0	0
R/W	:	—	R/W	R/W	R/W	R/W	R/W	R/W	R/W

Stores output data for the port 3 pins (P36 to P30)

**P7DR—Port 7 Data Register****H'FF06****Port 7**

Bit	:	7	6	5	4	3	2	1	0
		P77DR	—	P75DR	P74DR	—	—	—	—
Initial value	:	0	Undefined	0	0	Undefined	Undefined	Undefined	Undefined
R/W	:	R/W	R/W	R/W	R/W	R/W	R/W	R/W	R/W

Stores output data for the port 7 pins (P77, P75, P74)

**PADR—Port A Data Register****H'FF09****Port A**

Bit	:	7	6	5	4	3	2	1	0
		—	—	—	—	PA3DR	PA2DR	PA1DR	PA0DR
Initial value	:	Undefined	Undefined	Undefined	Undefined	0	0	0	0
R/W	:	—	—	—	—	R/W	R/W	R/W	R/W

Stores output data for the port A pins (PA3 to PA0)

**PBDR—Port B Data Register****H'FF0A****Port B**

Bit	:	7	6	5	4	3	2	1	0
		PB7DR	PB6DR	PB5DR	PB4DR	PB3DR	PB2DR	PB1DR	PB0DR
Initial value	:	0	0	0	0	0	0	0	0
R/W	:	R/W	R/W	R/W	R/W	R/W	R/W	R/W	R/W

Stores output data for the port B pins (PB7 to PB0)

**PCDR—Port C Data Register****H'FF0B****Port C**

Bit	:	7	6	5	4	3	2	1	0
		PC7DR	PC6DR	PC5DR	PC4DR	PC3DR	PC2DR	PC1DR	PC0DR
Initial value	:	0	0	0	0	0	0	0	0
R/W	:	R/W	R/W	R/W	R/W	R/W	R/W	R/W	R/W

Stores output data for the port C pins (PC7 to PC0)

**PDDR—Port D Data Register****H'FF0C****Port D**

Bit	:	7	6	5	4	3	2	1	0
		PD7DR	PD6DR	PD5DR	PD4DR	PD3DR	PD2DR	PD1DR	PD0DR
Initial value	:	0	0	0	0	0	0	0	0
R/W	:	R/W	R/W	R/W	R/W	R/W	R/W	R/W	R/W

Stores output data for the port D pins (PD7 to PD0)

**PEDR—Port E Data Register****H'FF0D****Port E**

Bit	:	7	6	5	4	3	2	1	0
		PE7DR	PE6DR	PE5DR	PE4DR	PE3DR	PE2DR	PE1DR	PE0DR
Initial value	:	0	0	0	0	0	0	0	0
R/W	:	R/W	R/W	R/W	R/W	R/W	R/W	R/W	R/W

Stores output data for the port E pins (PE7 to PE0)

**PFDR—Port F Data Register****H'FF0E****Port F**

Bit	:	7	6	5	4	3	2	1	0
		PF7DR	PF6DR	PF5DR	PF4DR	PF3DR	PF2DR	PF1DR	PF0DR
Initial value	:	0	0	0	0	0	0	0	0
R/W	:	R/W	R/W	R/W	R/W	R/W	R/W	R/W	R/W

Stores output data for the port F pins (PF7 to PF0)

**PGDR—Port G Data Register****H'FF0F****Port G**

Bit	:	7	6	5	4	3	2	1	0
		—	—	—	PG4DR	PG3DR	PG2DR	PG1DR	—
Initial value	:	Undefined	Undefined	Undefined	0	0	0	0	Undefined
R/W	:	—	—	—	R/W	R/W	R/W	R/W	R/W

Stores output data for the port G pins (PG4 to PG1)



Bit	:	7	6	5	4	3	2	1	0
		CCLR2	CCLR1	CCLR0	CKEG1	CKEG0	TPSC2	TPSC1	TPSC0
Initial value	:	0	0	0	0	0	0	0	0
R/W	:	R/W	R/W	R/W	R/W	R/W	R/W	R/W	R/W

**Time Prescaler**

0	0	0	Internal clock: counts on $\phi/1$
		1	Internal clock: counts on $\phi/4$
	1	0	Internal clock: counts on $\phi/16$
		1	Internal clock: counts on $\phi/64$
1	0	0	External clock: counts on TCLKA pin input
		1	External clock: counts on TCLKB pin input
	1	0	Setting prohibited
		1	Setting prohibited

**Select the Input Clock Edge**

0	0	Count at rising edge
	1	Count at falling edge
1	—	Count at both edges

Note: The internal clock edge selection is valid when the input clock is  $\phi/4$  or slower. This setting is ignored if the input clock is  $\phi/1$ , or when overflow/underflow of another channel is selected.

**Counter Clear**

0	0	0	TCNT clearing disabled
		1	TCNT cleared by TGRA compare match/input capture
	1	0	TCNT cleared by TGRB compare match/input capture
1		TCNT cleared by counter clearing for another channel performing synchronous clearing/synchronous operation *1	
1	0	0	TCNT clearing disabled
		1	TCNT cleared by TGRC compare match/input capture *2
	1	0	TCNT cleared by TGRD compare match/input capture *2
		1	TCNT cleared by counter clearing for another channel performing synchronous clearing/synchronous operation *1

Notes: \*1 Synchronous operation setting is performed by setting the SYNC bit in TSYR to 1.

\*2 When TGRC or TGRD is used as a buffer register, TCNT is not cleared because the buffer register setting has priority, and compare match/input capture does not occur.

Bit	:	7	6	5	4	3	2	1	0
		—	—	BFB	BFA	MD3	MD2	MD1	MD0
Initial value	:	1	1	0	0	0	0	0	0
R/W	:	—	—	R/W	R/W	R/W	R/W	R/W	R/W

**Modes**

0	0	0	0	Normal operation
		1	Reserved	
	1	0	0	PWM mode 1
		1	0	PWM mode 2
1	0	0	0	Phase counting mode 1
		1	0	Phase counting mode 2
	1	0	0	Phase counting mode 3
		1	0	Phase counting mode 4
1	*	*	*	Setting prohibited

\*: Don't care

- Notes:
1. MD3 is a reserved bit. In a write, it should always be written with 0.
  2. Phase counting mode cannot be set for channel 0. In this case, 0 should always be written to MD2.

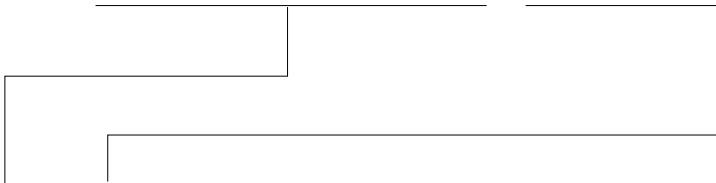
**Buffer Operation A**

0	TGRA operates normally
1	TGRA and TGRC used together for buffer operation

**Buffer Operation B**

0	TGRB operates normally
1	TGRB and TGRD used together for buffer operation

Bit	:	7	6	5	4	3	2	1	0
		IOB3	IOB2	IOB1	IOB0	IOA3	IOA2	IOA1	IOA0
Initial value	:	0	0	0	0	0	0	0	0
R/W	:	R/W	R/W	R/W	R/W	R/W	R/W	R/W	R/W



**TGR0A I/O Control**

0	0	0	0	TGR0A is output compare register	Output disabled			
			1		Initial output is 0 output	0 output at compare match		
			1		1 output at compare match	Toggle output at compare match		
	1	0	0		Output disabled			
			1		Initial output is 1 output	0 output at compare match		
			1		1 output at compare match	Toggle output at compare match		
1	0	0	1	TGR0A is input capture register	Capture input source is TIOCA0 pin			
					1	*	Input capture at rising edge	Input capture at falling edge
						*	Input capture at both edges	
1	*	*	Capture input source is channel 1/count clock		Input capture at TCNT1 count-up/count-down			

\*: Don't care

**TGR0B I/O Control**

0	0	0	0	TGR0B is output compare register	Output disabled			
			1		Initial output is 0 output	0 output at compare match		
			1		1 output at compare match	Toggle output at compare match		
	1	0	0		Output disabled			
					1	Initial output is 1 output	0 output at compare match	
					1	1 output at compare match	Toggle output at compare match	
1	0	0	1	TGR0B is input capture register	Capture input source is TIOCB0 pin			
					1	*	Input capture at rising edge	Input capture at falling edge
						*	Input capture at both edges	
1	*	*	Capture input source is channel 1/count clock		Input capture at TCNT1 count-up/count-down*1			

\*: Don't care

Note: \*1 When bits TPSC2 to TPSC0 in TCR1 are set to B'000 and  $\emptyset/1$  is used as the TCNT1 count clock, this setting is invalid and input capture is not generated.

Bit	:	7	6	5	4	3	2	1	0
		IOD3	IOD2	IOD1	IOD0	IOC3	IOC2	IOC1	IOC0
Initial value	:	0	0	0	0	0	0	0	0
R/W	:	R/W	R/W	R/W	R/W	R/W	R/W	R/W	R/W

**TGR0C I/O Control**

0	0	0	0	TGR0C is output compare register*1	Output disabled	Initial output is 0 output	0 output at compare match	
			1			1 output at compare match		
			1		Toggle output at compare match			
	1	0	0	0		Output disabled	Initial output is 1 output	0 output at compare match
				1			1 output at compare match	
				1		Toggle output at compare match		
1	0	0	0	TGR0C is input capture register*1	Capture input source is TIOCC0 pin	Input capture at rising edge		
			1			Input capture at falling edge		
	1	*	*	*		Capture input source is channel 1/count clock	Input capture at both edges	
				*			Input capture at TCNT1 count-up/count-down	

\*: Don't care

Note: \*1 When the BFA bit in TMDR0 is set to 1 and TGR0C is used as a buffer register, this setting is invalid and input capture/output compare is not generated.

**TGR0D I/O Control**

0	0	0	0	TGR0D is output compare register*2	Output disabled	Initial output is 0 output	0 output at compare match	
			1			1 output at compare match		
			1		Toggle output at compare match			
	1	0	0	0		Output disabled	Initial output is 1 output	0 output at compare match
				1			1 output at compare match	
				1		Toggle output at compare match		
1	0	0	0	TGR0D is input capture register*2	Capture input source is TIOCD0 pin	Input capture at rising edge		
			1			Input capture at falling edge		
	1	*	*	*		Capture input source is channel 1/count clock	Input capture at both edges	
				*			Input capture at TCNT1 count-up/count-down*1	

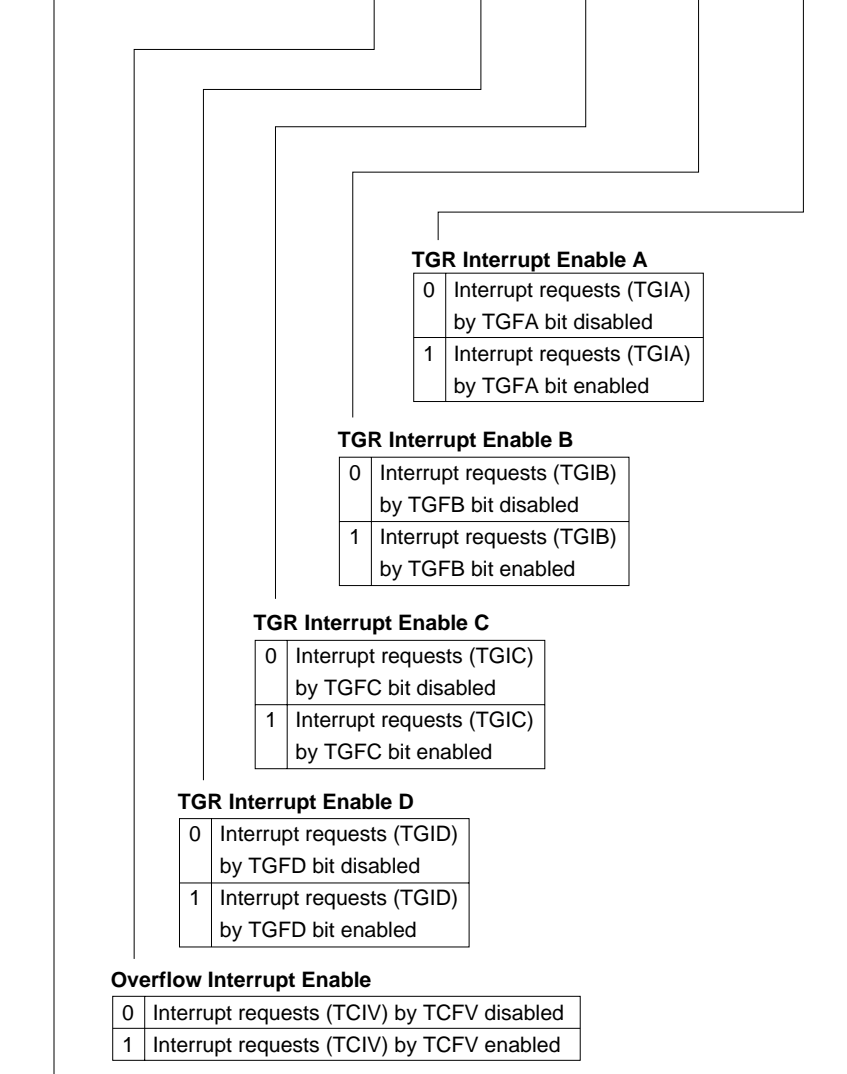
\*: Don't care

Notes: \*1 When bits TPSC2 to TPSC0 in TCR1 are set to B'000 and  $\phi$ /1 is used as the TCNT1 count clock, this setting is invalid and input capture is not generated.

\*2 When the BFB bit in TMDR0 is set to 1 and TGR0D is used as a buffer register, this setting is invalid and input capture/output compare is not generated.

Note: When TGRC or TGRD is designated for buffer operation, this setting is invalid and the register operates as a buffer register.

Bit	:	7	6	5	4	3	2	1	0
		TTGE	—	—	TCIEV	TGIED	TGIEC	TGIEB	TGIEA
Initial value	:	0	1	0	0	0	0	0	0
R/W	:	R/W	—	—	R/W	R/W	R/W	R/W	R/W



**TGR Interrupt Enable A**

0	Interrupt requests (TGIA) by TGFA bit disabled
1	Interrupt requests (TGIA) by TGFA bit enabled

**TGR Interrupt Enable B**

0	Interrupt requests (TGIB) by TGFB bit disabled
1	Interrupt requests (TGIB) by TGFB bit enabled

**TGR Interrupt Enable C**

0	Interrupt requests (TGIC) by TGFC bit disabled
1	Interrupt requests (TGIC) by TGFC bit enabled

**TGR Interrupt Enable D**

0	Interrupt requests (TGID) by TGFD bit disabled
1	Interrupt requests (TGID) by TGFD bit enabled

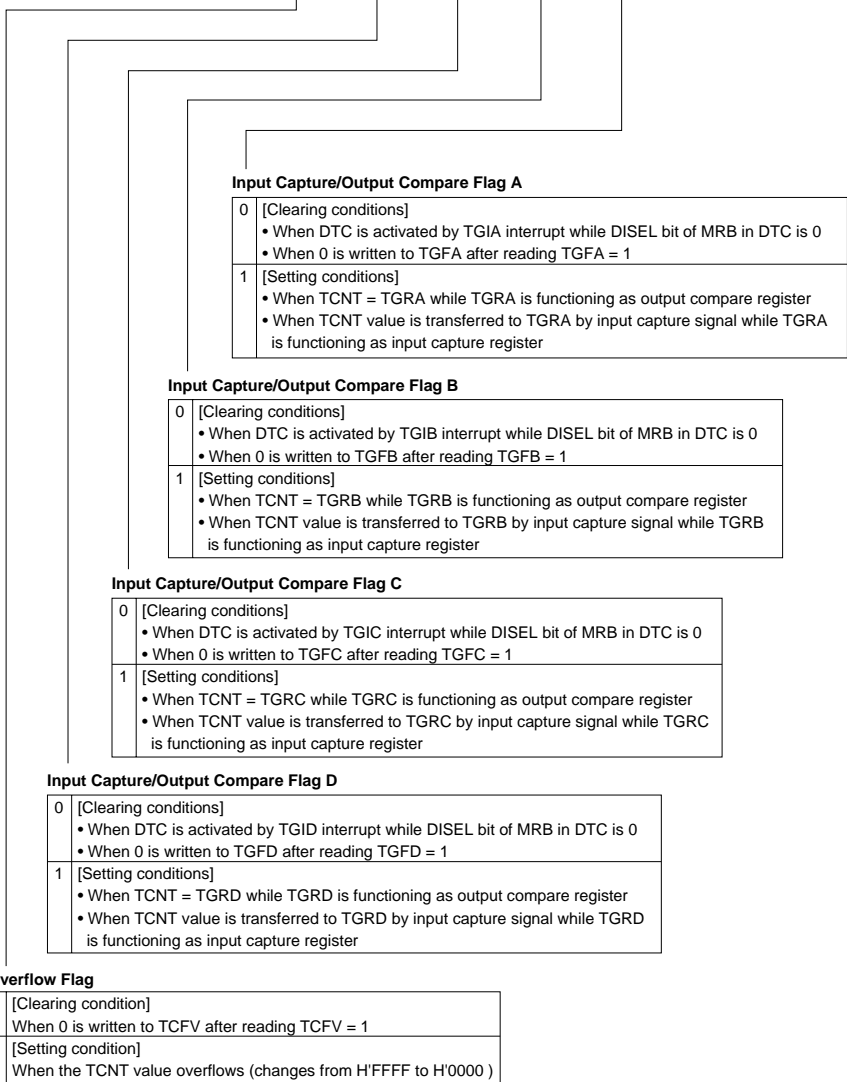
**Overflow Interrupt Enable**

0	Interrupt requests (TCIV) by TCFV disabled
1	Interrupt requests (TCIV) by TCFV enabled

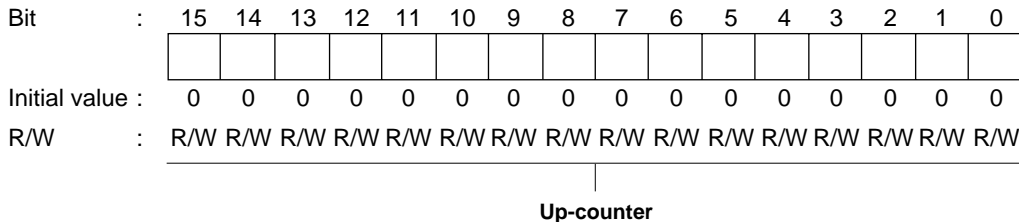
**A/D Conversion Start Request Enable**

0	A/D conversion start request generation disabled
1	A/D conversion start request generation enabled

Bit	7	6	5	4	3	2	1	0
	—	—	—	TCFV	TGFD	TGFC	TGFB	TGFA
Initial value	1	1	0	0	0	0	0	0
R/W	—	—	—	R/(W)*	R/(W)*	R/(W)*	R/(W)*	R/(W)*



Note: \* Can only be written with 0 for flag clearing.



**TGR0A—Timer General Register 0A**

**H'FF18**

**TPU0**

**TGR0B—Timer General Register 0B**

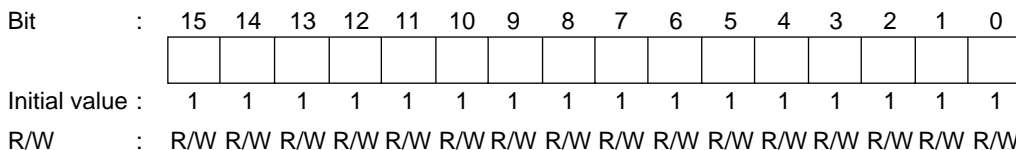
**H'FF1A**

**TGR0C—Timer General Register 0C**

**H'FF1C**

**TGR0D—Timer General Register 0D**

**H'FF1E**



Bit	:	7	6	5	4	3	2	1	0
		—	CCLR1	CCLR0	CKEG1	CKEG0	TPSC2	TPSC1	TPSC0
Initial value	:	0	0	0	0	0	0	0	0
R/W	:	—	R/W	R/W	R/W	R/W	R/W	R/W	R/W

**Time Prescaler**

0	0	0	Internal clock: counts on $\phi/1$
		1	Internal clock: counts on $\phi/4$
1	0	0	Internal clock: counts on $\phi/16$
		1	Internal clock: counts on $\phi/64$
1	0	0	External clock: counts on TCLKA pin input
		1	External clock: counts on TCLKB pin input
	1	0	Internal clock: counts on $\phi/256$
		1	Setting prohibited

Note: This setting is ignored when channel 1 is in phase counting mode.

**Select the Input Clock Edge**

0	0	Count at rising edge
	1	Count at falling edge
1	—	Count at both edges

- Notes:
1. This setting is ignored when channel 1 is in phase counting mode.
  2. The internal clock edge selection is valid when the input clock is  $\phi/4$  or slower. This setting is ignored if the input clock is  $\phi/1$ , or when overflow/underflow of another channel is selected.

**Counter Clear**

0	0	TCNT clearing disabled
	1	TCNT cleared by TGRA compare match/input capture
1	0	TCNT cleared by TGRB compare match
	1	TCNT cleared by counter clearing for another channel performing synchronous clearing/synchronous operation*

Note: \* Synchronous operation setting is performed by setting the SYNC bit in TSYR to 1.



Bit	:	7	6	5	4	3	2	1	0
		—	—	—	—	MD3	MD2	MD1	MD0
Initial value	:	1	1	0	0	0	0	0	0
R/W	:	—	—	—	—	R/W	R/W	R/W	R/W

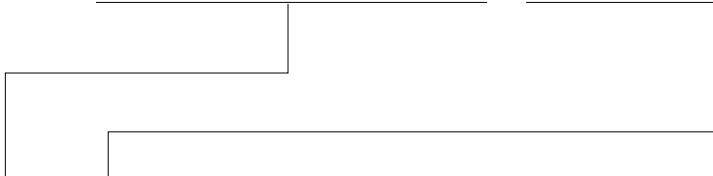
**Mode**

0	0	0	0	Normal operation	
		1	Reserved		
		1	0	PWM mode 1	
			1	PWM mode 2	
	1	0	0	Phase counting mode 1	
			1	Phase counting mode 2	
			1	0	Phase counting mode 3
				1	Phase counting mode 4
1	*	*	*	Setting prohibited	

\*: Don't care

Note: MD3 is a reserved bit. In a write, it should always be written with 0.

Bit	:	7	6	5	4	3	2	1	0
		IOB3	IOB2	IOB1	IOB0	IOA3	IOA2	IOA1	IOA0
Initial value	:	0	0	0	0	0	0	0	0
R/W	:	R/W	R/W	R/W	R/W	R/W	R/W	R/W	R/W



**TGR1A I/O Control**

0	0	0	0	TGR1A is output compare register	Output disabled			
					1	Initial output is 0 output	0 output at compare match	
					0	Initial output is 0 output	1 output at compare match	
		1	0		0	Output disabled		
						1	Initial output is 1 output	0 output at compare match
						0	Initial output is 1 output	1 output at compare match
	1	0	0	TGR1A is input capture register	Capture input source is TIOCA1 pin			
					1	Capture input source is TIOCA1 pin	Input capture at rising edge	
					0	Capture input source is TIOCA1 pin	Input capture at falling edge	
		1	*		*	Capture input source is TGR0A compare match/ input capture		
						1	Capture input source is TGR0A compare match/ input capture	Input capture at both edges
						0	Capture input source is TGR0A compare match/ input capture	Input capture at generation of channel 0/TGR0A compare match/ input capture

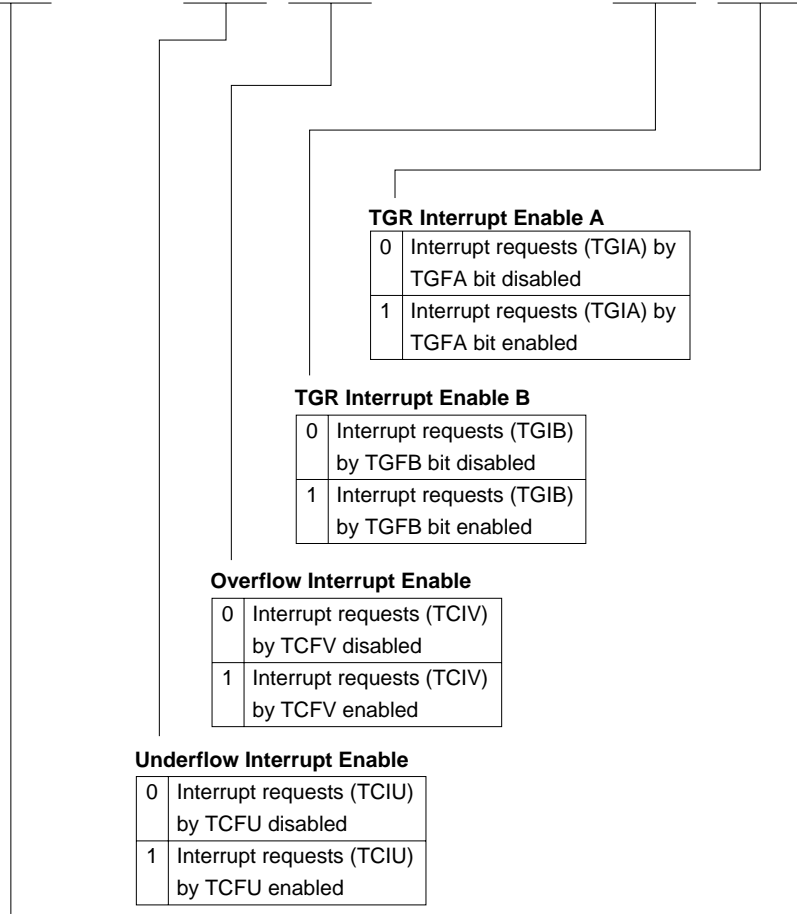
\*: Don't care

**TGR1B I/O Control**

0	0	0	0	TGR1B is output compare register	Output disabled			
					1	Initial output is 0 output	0 output at compare match	
					0	Initial output is 0 output	1 output at compare match	
		1	0		0	Output disabled		
						1	Initial output is 1 output	0 output at compare match
						0	Initial output is 1 output	1 output at compare match
	1	*	*	—	Setting prohibited			
					1	Setting prohibited	Toggle output at compare match	
					0	Setting prohibited	Toggle output at compare match	

\*: Don't care

Bit	:	7	6	5	4	3	2	1	0
		TTGE	—	TCIEU	TCIEV	—	—	TGIEB	TGIEA
Initial value	:	0	1	0	0	0	0	0	0
R/W	:	R/W	—	R/W	R/W	—	—	R/W	R/W



**TGR Interrupt Enable A**

0	Interrupt requests (TGIA) by TGFA bit disabled
1	Interrupt requests (TGIA) by TGFA bit enabled

**TGR Interrupt Enable B**

0	Interrupt requests (TGIB) by TGFB bit disabled
1	Interrupt requests (TGIB) by TGFB bit enabled

**Overflow Interrupt Enable**

0	Interrupt requests (TCIV) by TCFV disabled
1	Interrupt requests (TCIV) by TCFV enabled

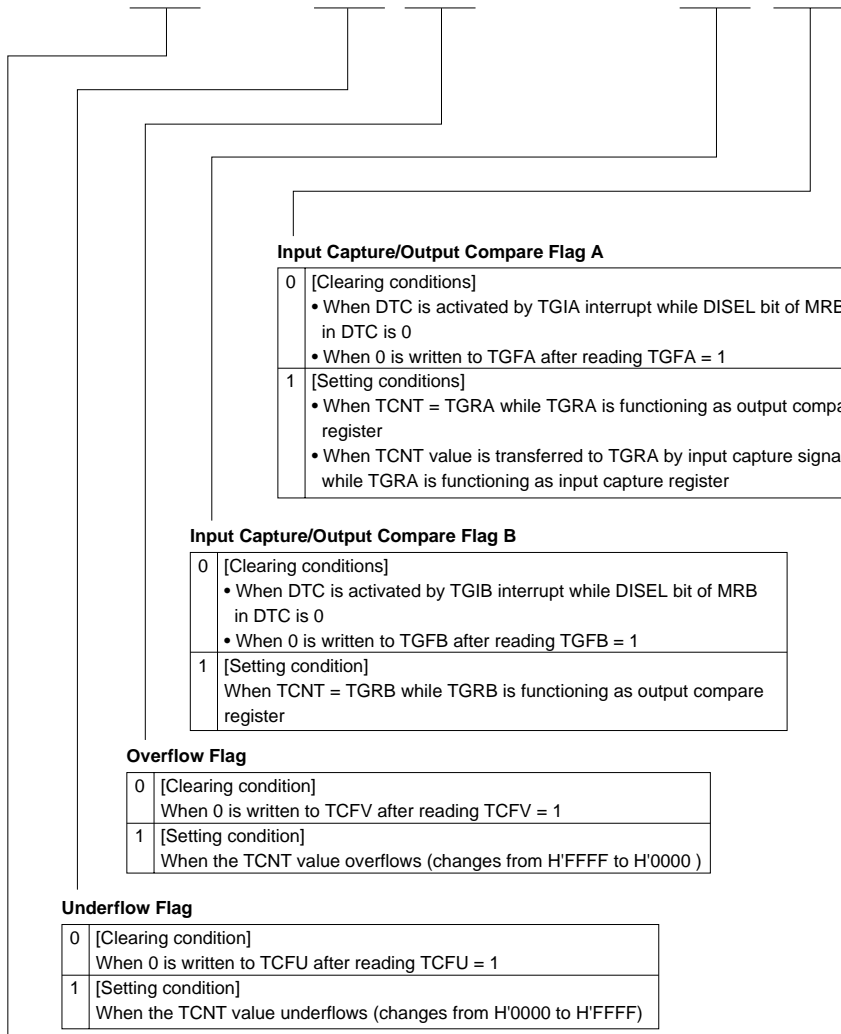
**Underflow Interrupt Enable**

0	Interrupt requests (TCIU) by TCFU disabled
1	Interrupt requests (TCIU) by TCFU enabled

**A/D Conversion Start Request Enable**

0	A/D conversion start request generation disabled
1	A/D conversion start request generation enabled

Bit	:	7	6	5	4	3	2	1	0
		TCFD	—	TCFU	TCFV	—	—	TGFB	TGFA
Initial value	:	1	1	0	0	0	0	0	0
R/W	:	R	—	R/(W)*	R/(W)*	—	—	R/(W)*	R/(W)*



**Input Capture/Output Compare Flag A**

0	[Clearing conditions]
	<ul style="list-style-type: none"> <li>When DTC is activated by TGIA interrupt while DISEL bit of MRB in DTC is 0</li> <li>When 0 is written to TGFA after reading TGFA = 1</li> </ul>
1	[Setting conditions]
	<ul style="list-style-type: none"> <li>When TCNT = TGRA while TGRA is functioning as output compare register</li> <li>When TCNT value is transferred to TGRA by input capture signal while TGRA is functioning as input capture register</li> </ul>

**Input Capture/Output Compare Flag B**

0	[Clearing conditions]
	<ul style="list-style-type: none"> <li>When DTC is activated by TGIB interrupt while DISEL bit of MRB in DTC is 0</li> <li>When 0 is written to TGFB after reading TGFB = 1</li> </ul>
1	[Setting condition]
	When TCNT = TGRB while TGRB is functioning as output compare register

**Overflow Flag**

0	[Clearing condition]
	When 0 is written to TCFV after reading TCFV = 1
1	[Setting condition]
	When the TCNT value overflows (changes from H'FFFF to H'0000)

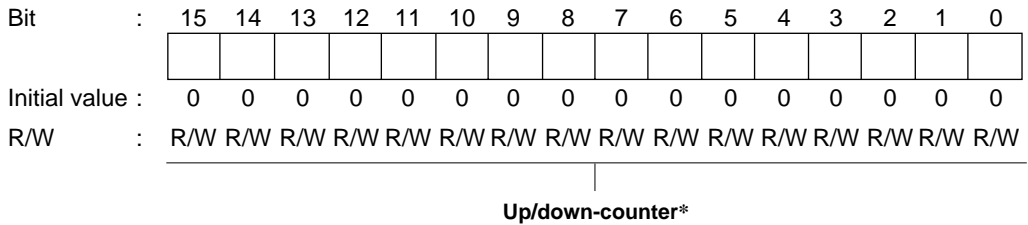
**Underflow Flag**

0	[Clearing condition]
	When 0 is written to TCFU after reading TCFU = 1
1	[Setting condition]
	When the TCNT value underflows (changes from H'0000 to H'FFFF)

**Count Direction Flag**

0	TCNT counts down
1	TCNT counts up

Note: \* Can only be written with 0 for flag clearing.



Note : \* These counters can be used as up/down-counters only in phase counting mode or when counting overflow/underflow on another channel. In other cases they function as up-counters.

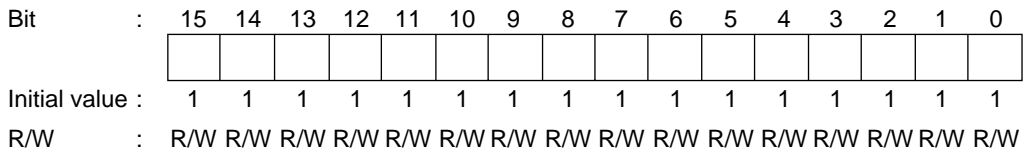
**TGR1A—Timer General Register 1A**

**H'FF28**

**TPU1**

**TGR1B—Timer General Register 1B**

**H'FF2A**



Bit	:	7	6	5	4	3	2	1	0
		—	CCLR1	CCLR0	CKEG1	CKEG0	TPSC2	TPSC1	TPSC0
Initial value	:	0	0	0	0	0	0	0	0
R/W	:	—	R/W	R/W	R/W	R/W	R/W	R/W	R/W

**Time Prescaler**

0	0	0	Internal clock: counts on $\phi/1$
		1	Internal clock: counts on $\phi/4$
1	0	0	Internal clock: counts on $\phi/16$
		1	Internal clock: counts on $\phi/64$
1	0	0	External clock: counts on TCLKA pin input
		1	External clock: counts on TCLKB pin input
	1	0	Setting prohibited
		1	Internal clock: counts on $\phi/1024$

Note: This setting is ignored when channel 2 is in phase counting mode.

**Select the Input Clock Edge**

0	0	Count at rising edge
	1	Count at falling edge
1	—	Count at both edges

Note: The internal clock edge selection is valid when the input clock is  $\phi/4$  or slower. This setting is ignored if the input clock is  $\phi/1$ , or when overflow/underflow of another channel is selected.

**Counter Clear**

0	0	TCNT clearing disabled
	1	TCNT cleared by TGRA compare match/input capture
1	0	TCNT cleared by TGRB compare match
	1	TCNT cleared by counter clearing for another channel performing synchronous clearing/synchronous operation*

Note: \* Synchronous operation setting is performed by setting the SYNC bit in TSYR to 1.

Bit	:	7	6	5	4	3	2	1	0
		—	—	—	—	MD3	MD2	MD1	MD0
Initial value	:	1	1	0	0	0	0	0	0
R/W	:	—	—	—	—	R/W	R/W	R/W	R/W

**Mode**

0	0	0	0	Normal operation
		1	Reserved	
		1	0	PWM mode 1
			1	PWM mode 2
	1	0	0	Phase counting mode 1
			1	Phase counting mode 2
			1	Phase counting mode 3
			1	Phase counting mode 4
1	*	*	*	Setting prohibited

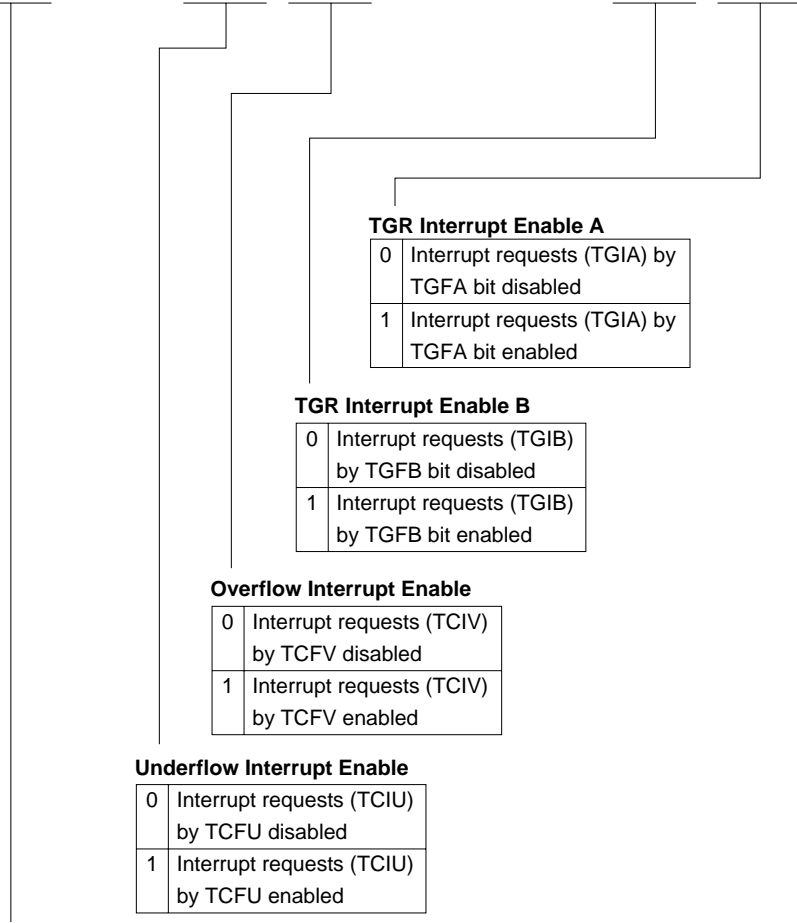
\*: Don't care

- Note: 1. MD3 is a reserved bit. In a write, it should always be written with 0.  
 2. Phase counting mode cannot be set for channel 2. In this case, 0 should always be written to MD2.





Bit	:	7	6	5	4	3	2	1	0
		TTGE	—	TCIEU	TCIEV	—	—	TGIEB	TGIEA
Initial value	:	0	1	0	0	0	0	0	0
R/W	:	R/W	—	R/W	R/W	—	—	R/W	R/W



**TGR Interrupt Enable A**

0	Interrupt requests (TGIA) by TGFA bit disabled
1	Interrupt requests (TGIA) by TGFA bit enabled

**TGR Interrupt Enable B**

0	Interrupt requests (TGIB) by TGFB bit disabled
1	Interrupt requests (TGIB) by TGFB bit enabled

**Overflow Interrupt Enable**

0	Interrupt requests (TCIV) by TCFV disabled
1	Interrupt requests (TCIV) by TCFV enabled

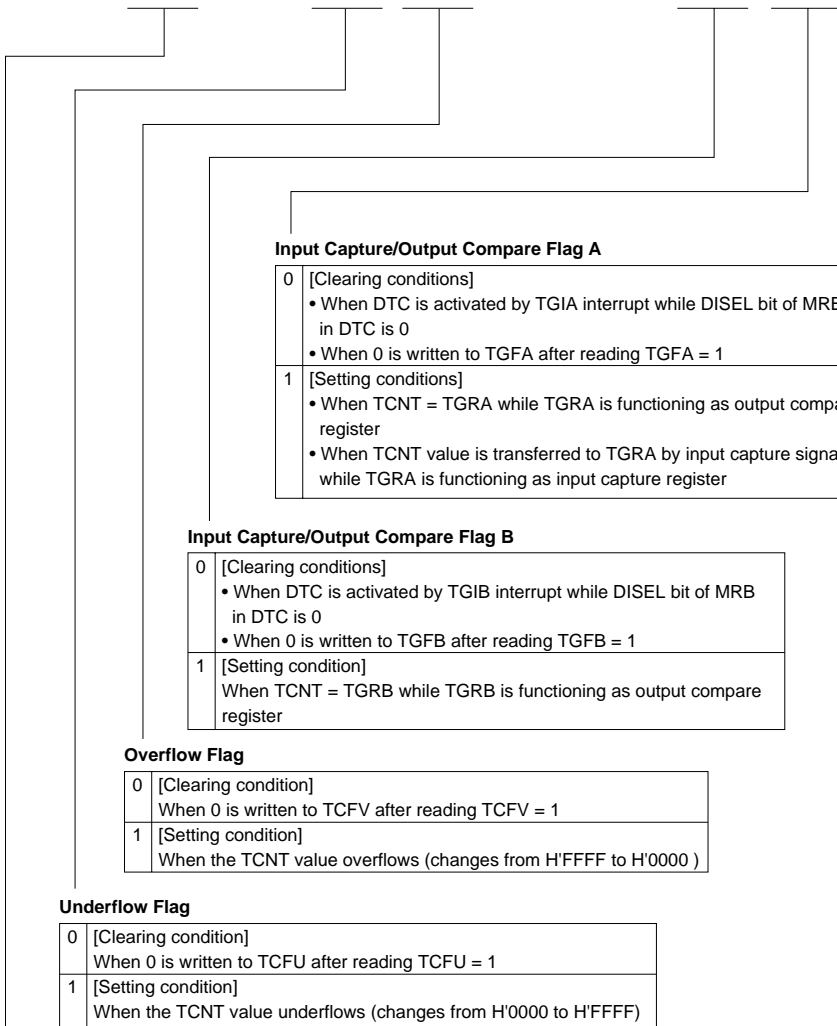
**Underflow Interrupt Enable**

0	Interrupt requests (TCIU) by TCFU disabled
1	Interrupt requests (TCIU) by TCFU enabled

**A/D Conversion Start Request Enable**

0	A/D conversion start request generation disabled
1	A/D conversion start request generation enabled

Bit	:	7	6	5	4	3	2	1	0
		TCFD	—	TCFU	TCFV	—	—	TGFB	TGFA
Initial value	:	1	1	0	0	0	0	0	0
R/W	:	R	—	R/(W)*	R/(W)*	—	—	R/(W)*	R/(W)*



**Input Capture/Output Compare Flag A**

0	[Clearing conditions] • When DTC is activated by TGIA interrupt while DISEL bit of MRB in DTC is 0 • When 0 is written to TGFA after reading TGFA = 1
1	[Setting conditions] • When TCNT = TGRA while TGRA is functioning as output compare register • When TCNT value is transferred to TGRA by input capture signal while TGRA is functioning as input capture register

**Input Capture/Output Compare Flag B**

0	[Clearing conditions] • When DTC is activated by TGIB interrupt while DISEL bit of MRB in DTC is 0 • When 0 is written to TGFB after reading TGFB = 1
1	[Setting condition] When TCNT = TGRB while TGRB is functioning as output compare register

**Overflow Flag**

0	[Clearing condition] When 0 is written to TCFV after reading TCFV = 1
1	[Setting condition] When the TCNT value overflows (changes from H'FFFF to H'0000 )

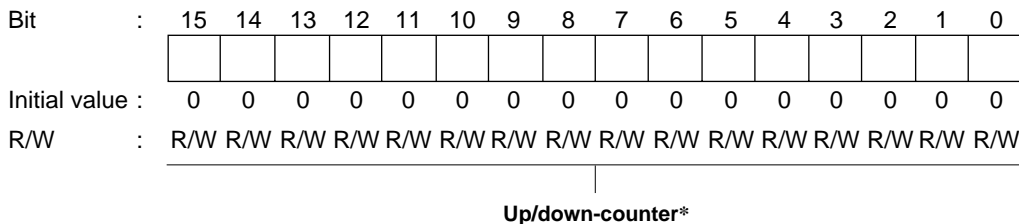
**Underflow Flag**

0	[Clearing condition] When 0 is written to TCFU after reading TCFU = 1
1	[Setting condition] When the TCNT value underflows (changes from H'0000 to H'FFFF)

**Count Direction Flag**

0	TCNT counts down
1	TCNT counts up

Note: \* Can only be written with 0 for flag clearing.



Note : \* These counters can be used as up/down-counters only in phase counting mode or when counting overflow/underflow on another channel. In other cases they function as up-counters.

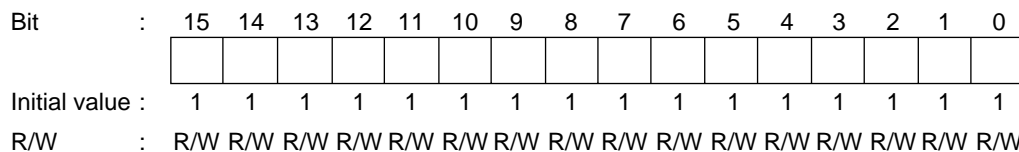
**TGR2A—Timer General Register 2A**

**H'FF38**

**TPU2**

**TGR2B—Timer General Register 2B**

**H'FF3A**



Bit	:	7	6	5	4	3	2	1	0
		CMIEB	CMIEA	OVIE	CCLR1	CCLR0	CKS2	CKS1	CKS0
Initial value:		0	0	0	0	0	0	0	0
R/W	:	R/W	R/W	R/W	R/W	R/W	R/W	R/W	R/W

**Clock Select**

0	0	0	Clock input disabled
		1	Internal clock, counted at falling edge of $\phi/8$
1	0	0	Internal clock, counted at falling edge of $\phi/64$
		1	Internal clock, counted at falling edge of $\phi/8192$
1	0	0	For channel 0: count at TCNT1 overflow signal* For channel 1: count at TCNT0 compare match A*
		1	Setting prohibited
		0	Setting prohibited
		1	Setting prohibited

Note: If the count input of channel 0 is the TCNT1 overflow signal and that of channel 1 is the TCNT0 compare match signal, no incrementing clock is generated. Do not use this setting.

**Counter Clear**

0	0	Clear is disabled
		Clear by compare match A
1	0	Clear by compare match B
		Setting prohibited

**Timer Overflow Interrupt Enable**

0	OVF interrupt requests (OVI) are disabled
1	OVF interrupt requests (OVI) are enabled

**Compare Match Interrupt Enable A**

0	CMFA interrupt requests (CMIA) are disabled
1	CMFA interrupt requests (CMIA) are enabled

**Compare Match Interrupt Enable B**

0	CMFB interrupt requests (CMIB) are disabled
1	CMFB interrupt requests (CMIB) are enabled

**TCSR0**

Bit	:	7	6	5	4	3	2	1	0
		CMFB	CMFA	OVF	ADTE	—	—	—	—
Initial value	:	0	0	0	0	0	0	0	0
R/W	:	R/(W)*	R/(W)*	R/(W)*	R/W	R/W	R/W	R/W	R/W

**TCSR1**

Bit	:	7	6	5	4	3	2	1	0
		CMFB	CMFA	OVF	—	—	—	—	—
Initial value	:	0	0	0	1	0	0	0	0
R/W	:	R/(W)*	R/(W)*	R/(W)*	—	R/W	R/W	R/W	R/W

**Reserved**  
Only 0 should be written to these bits

**A/D Trigger Enable (TCSR0 Only)**

0	A/D converter start requests by compare match A are disabled
1	A/D converter start requests by compare match A are enabled

**Timer Overflow Flag**

0	[Clearing condition] Cleared by reading OVF when OVF = 1, then writing 0 to OVF
1	[Setting condition] Set when TCNT overflows from H'FF to H'00

**Compare Match Flag A**

0	[Clearing conditions] <ul style="list-style-type: none"> <li>• Cleared by reading CMFA when CMFA = 1, then writing 0 to CMFA</li> <li>• When DTC is activated by CMIA interrupt while DISEL bit of MRB in DTC is 0</li> </ul>
1	[Setting condition] Set when TCNT matches TCORA

**Compare Match Flag B**

0	[Clearing conditions] <ul style="list-style-type: none"> <li>• Cleared by reading CMFB when CMFB = 1, then writing 0 to CMFB</li> <li>• When DTC is activated by CMIB interrupt while DISEL bit of MRB in DTC is 0</li> </ul>
1	[Setting condition] Set when TCNT matches TCORB

Note: \* Only 0 can be written to bits 7 to 5, to clear these flags.

**TCORA0—Time Constant Register A0**

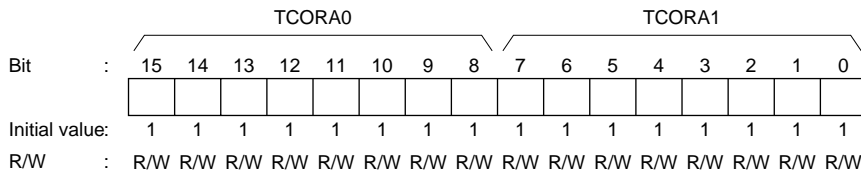
**H'FF6C**

**TMR0**

**TCORA1—Time Constant Register A1**

**H'FF6D**

**TMR1**



**TCORB0—Time Constant Register B0**

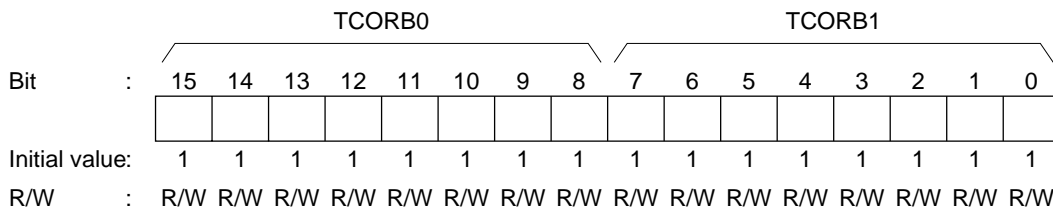
**H'FF6E**

**TMR0**

**TCORB1—Time Constant Register B1**

**H'FF6F**

**TMR1**



**TCNT0—Timer Counter 0**

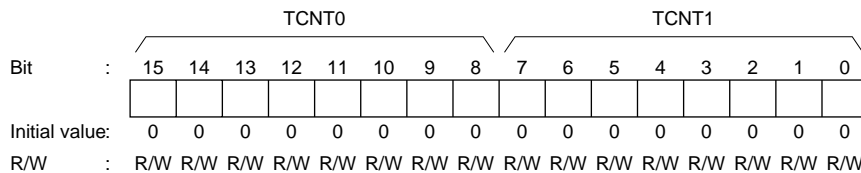
**H'FF70**

**TMR0**

**TCNT1—Timer Counter 1**

**H'FF71**

**TMR1**



Bit	:	7	6	5	4	3	2	1	0
		OVF	WT/IT	TME	—	—	CKS2	CKS1	CKS0
Initial value	:	0	0	0	1	1	0	0	0
R/W	:	R/(W)*1	R/W	R/W	—	—	R/W	R/W	R/W

**Clock Select**

CKS2	CKS1	CKS0	Clock	Overflow Period*2 (when $\phi = 10$ MHz)
0	0	0	$\phi/2$ (Initial value)	51.2 $\mu$ s
		1	$\phi/64$	1.6 ms
	1	0	$\phi/128$	3.2 ms
		1	$\phi/512$	13.2 ms
1	0	0	$\phi/2048$	52.4 ms
		1	$\phi/8192$	209.8 ms
	1	0	$\phi/32768$	838.8 ms
		1	$\phi/131072$	3.36 s

Note: \*2 The overflow period is the time from when TCNT starts counting up from H'00 until overflow occurs.

**Timer Enable**

0	TCNT is initialized to H'00 and count operation is halted
1	TCNT counts

**Timer Mode Select**

0	Interval timer mode: Interval timer interrupt (WOVI) request is sent to CPU when TCNT overflows
1	Watchdog timer mode: Internal reset can be selected when TCNT overflows*

Note: \* For details of case where TCNT overflows in watchdog timer mode. See section 12.2.3, Reset Control/Status Register (RSTCSR).

**Overflow Flag**

0	[Clearing conditions] • Read TCSR when OVF = 1, then write 0 in OVF*2
1	[Setting condition] When TCNT overflows (changes from H'FF to H'00) When internal reset request generation is selected in watchdog timer mode, OVF is cleared automatically by the internal reset.

Notes: \*1 Only 0 can be written, to clear the flag.

\*2 When the OVF flag is polled with the interval timer interrupt disabled, read the OVF bit while it is 1 at least twice.

TCSR is write-protected by a password to prevent accidental overwriting. For details see section 12.2.5, Notes on Register Access.

Bit	:	7	6	5	4	3	2	1	0
Initial value	:	0	0	0	0	0	0	0	0
R/W	:	R/W	R/W	R/W	R/W	R/W	R/W	R/W	R/W

RSTCSR—Reset Control/Status Register

Bit	:	7	6	5	4	3	2	1	0
		WOVF	RSTE	—	—	—	—	—	—
Initial value	:	0	0	0	1	1	1	1	1
R/W	:	R/(W)*	R/W	R/W	—	—	—	—	—

**Reserved**

Only 0 should be written to this bit

**Reset Enable**

0	No internal reset when TCNT overflows*
1	Internal reset is generated when TCNT overflows

Note: \* The chip is not reset internally, but TCNT and TCSR in WDT0 are reset.

**Watchdog Overflow Flag**

0	[Clearing condition] Cleared by reading RSTCSR when WOVF = 1, then writing 0 to WOVF
1	[Setting condition] When TCNT overflows (from H'FF to H'00) in watchdog timer mode

Note: \* Only 0 can be written, to clear the flag.

RSTCSR is write-protected by a password to prevent accidental overwriting. For details see section 12.2.5, Notes on Register Access.



Bit	:	7	6	5	4	3	2	1	0
		C/ $\bar{A}$	CHR	PE	O/ $\bar{E}$	STOP	MP	CKS1	CKS0
Initial value :		0	0	0	0	0	0	0	0
R/W	:	R/W	R/W	R/W	R/W	R/W	R/W	R/W	R/W

**Clock Select**

0	0	$\emptyset$ clock
	1	$\emptyset/4$ clock
1	0	$\emptyset/16$ clock
	1	$\emptyset/64$ clock

**Multiprocessor Mode**

0	Multiprocessor function disabled
1	Multiprocessor format selected

**Stop Bit Length**

0	1 stop bit
1	2 stop bits

**Parity Mode**

0	Even parity* <sup>1</sup>
1	Odd parity* <sup>2</sup>

Notes: \*1 When even parity is set, parity bit addition is performed in transmission so that the total number of 1-bits in the transmit character plus the parity bit is even. In reception, a check is performed to see if the total number of 1-bits in the receive character plus the parity bit is even.

\*2 When odd parity is set, parity bit addition is performed in transmission so that the total number of 1-bits in the transmit character plus the parity bit is odd. In reception, a check is performed to see if the total number of 1-bits in the receive character plus the parity bit is odd.

**Parity Enable**

0	Parity bit addition and checking disabled
1	Parity bit addition and checking enabled*

Note: \* When the PE bit is set to 1, an even or odd parity bit is added to transmit data according to the even or odd parity mode selection by the O/ $\bar{E}$  bit, and the parity bit in receive data is checked to see if it matches the even or odd mode selected by the O/ $\bar{E}$  bit.

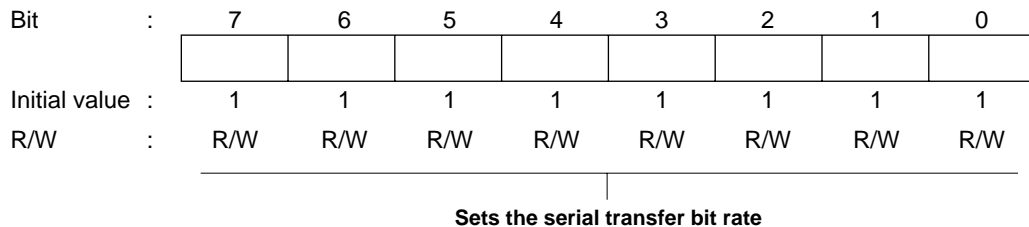
**Character Length**

0	8-bit data
1	7-bit data*

Note: \* When 7-bit data is selected, the MSB (bit 7) of TDR is not transmitted, and it is not possible to choose between LSB-first or MSB-first transfer.

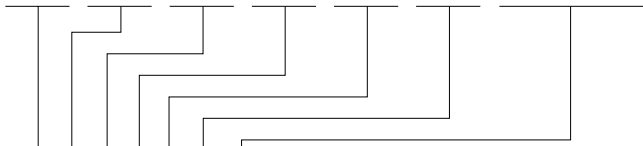
**Selects Asynchronous Mode or Clocked Synchronous Mode**

0	Asynchronous mode
1	Clocked synchronous mode



Note: For details, see section 13.2.8, Bit Rate Register (BRR)

Bit	:	7	6	5	4	3	2	1	0
		TIE	RIE	TE	RE	MPIE	TEIE	CKE1	CKE0
Initial value	:	0	0	0	0	0	0	0	0
R/W	:	R/W	R/W	R/W	R/W	R/W	R/W	R/W	R/W



**Clock Enable**

0	0	Asynchronous mode	Internal clock/SCK pin functions as I/O port
	1	Clocked synchronous mode	Internal clock/SCK pin functions as serial clock output
1	0	Asynchronous mode	Internal clock/SCK pin functions as clock output*1
	1	Clocked synchronous mode	Internal clock/SCK pin functions as serial clock output
1	0	Asynchronous mode	External clock/SCK pin functions as clock input*2
	1	Clocked synchronous mode	External clock/SCK pin functions as serial clock input
1	0	Asynchronous mode	External clock/SCK pin functions as clock input*2
	1	Clocked synchronous mode	External clock/SCK pin functions as serial clock input

**Transmit End Interrupt Enable**

0	Transmit end interrupt (TEI) request disabled*3
1	Transmit end interrupt (TEI) request enabled*3

**Multiprocessor Interrupt Enable**

0	Multiprocessor interrupts disabled [Clearing conditions] • When the MPIE bit is cleared to 0 • When MPB= 1 data is received
1	Multiprocessor interrupts enabled*4 Receive interrupt (RXI) requests, receive error interrupt (ERI) requests, and setting of the RDRF, FER, and ORER flags in SSR are disabled until data with the multiprocessor bit set to 1 is received.

**Receive Enable**

0	Reception disabled*5
1	Reception enabled*6

**Transmit Enable**

0	Transmission disabled*7
1	Transmission enabled*8

**Receive Interrupt Enable**

0	Receive data full interrupt (RXI) request and receive error interrupt (ERI) request disabled*9
1	Receive data full interrupt (RXI) request and receive error interrupt (ERI) request enabled

**Transmit Interrupt Enable**

0	Transmit data empty interrupt (TXI) requests disabled
1	Transmit data empty interrupt (TXI) requests enabled

Note: TXI cancellation can be performed by reading 1 from the TDRE flag, then clearing it to 0, or by clearing the TIE bit to 0.

- Notes:
- \*1 Outputs a clock of the same frequency as the bit rate.
  - \*2 Inputs a clock with a frequency 16 times the bit rate.
  - \*3 TEI cancellation can be performed by reading 1 from the TDRE flag in SSR, then clearing it to 0 and clearing the TEND flag to 0, or by clearing the TEIE bit to 0.
  - \*4 When receive data including MPB = 0 is received, receive data transfer from RSR to RDR, receive error detection, and setting of the RDRF, FER, and ORER flags in SSR, is not performed. When receive data including MPB = 1 is received, the MPB bit in SSR is set to 1, the MPIE bit is cleared to 0 automatically, and generation of RXI and ERI interrupts (when the TIE and RIE bits in SCR are set to 1) and FER and ORER flag setting is enabled.
  - \*5 Clearing the RE bit to 0 does not affect the RDRF, FER, PER, and ORER flags, which retain their states.
  - \*6 Serial reception is started in this state when a start bit is detected in asynchronous mode or serial clock input is detected in clocked synchronous mode. SMR setting must be performed to decide the receive format before setting the RE bit to 1.
  - \*7 The TDRE flag in SSR is fixed at 1.
  - \*8 In this state, serial transmission is started when transmit data is written to TDR and the TDRE flag in SSR is cleared to 0. SMR setting must be performed to decide the transmit format before setting the TE bit to 1.
  - \*9 RXI and ERI cancellation can be performed by reading 1 from the RDRF flag, or the FER, PER, or ORER flag, then clearing the flag to 0, or by clearing the RIE bit to 0.

Bit	:	7	6	5	4	3	2	1	0
Initial value	:	1	1	1	1	1	1	1	1
R/W	:	R/W	R/W	R/W	R/W	R/W	R/W	R/W	R/W

Stores data for serial transmission

Bit	:	7	6	5	4	3	2	1	0
		TDRE	RDRF	ORER	FER	PER	TEND	MPB	MPBT
Initial value	:	1	0	0	0	0	1	0	0
R/W	:	R/(W)*1	R/(W)*1	R/(W)*1	R/(W)*1	R/(W)*1	R	R	R/W

**Multiprocessor Bit Transfer**

0	Data with a 0 multiprocessor bit is transmitted
1	Data with a 1 multiprocessor bit is transmitted

**Multiprocessor Bit**

0	[Clearing condition] When data with a 0 multiprocessor bit is received
1	[Setting condition] When data with a 1 multiprocessor bit is received

**Transmit End**

0	[Clearing conditions] • When 0 is written to TDRE after reading TDRE = 1 • When the DTC is activated by a TXI interrupt and writes data to TDR
1	[Setting conditions] • When the TE bit in SCR is 0 • When TDRE = 1 at transmission of the last bit of a 1-byte serial transmit character

**Parity Error**

0	[Clearing condition] When 0 is written to PER after reading PER = 1
1	[Setting condition] When, in reception, the number of 1 bits in the receive data plus the parity bit does not match the parity setting (even or odd) specified by the O/E bit in SMR*2

**Framing Error**

0	[Clearing condition] • When 0 is written to FER after reading FER = 1
1	[Setting condition] When the SCI checks whether the stop bit at the end of the receive data when reception ends, and the stop bit is 0*3

**Overrun Error**

0	[Clearing condition] When 0 is written to ORER after reading ORER = 1
1	[Setting condition] When the next serial reception is completed while RDRF = 1*4

**Receive Data Register Full**

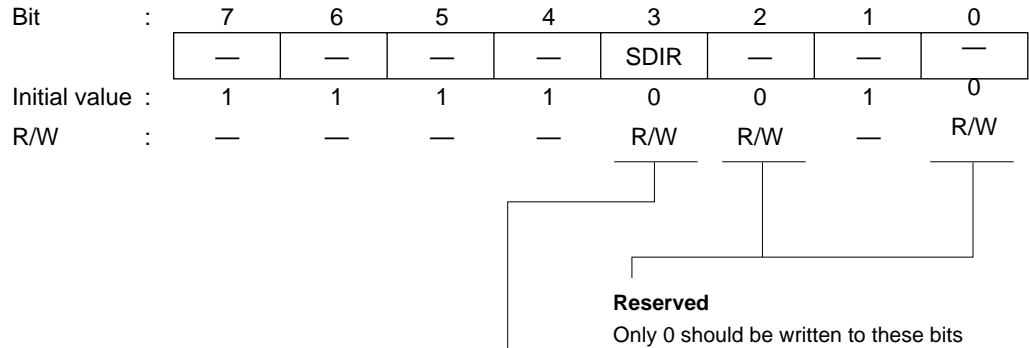
0	[Clearing conditions] • When 0 is written to RDRF after reading RDRF = 1 • When the DTC is activated by an RXI interrupt and reads data from RDR
1	[Setting condition] When serial reception ends normally and receive data is transferred from RSR to RDR

Note: RDR and the RDRF flag are not affected and retain their previous values when an error is detected during reception or when the RE bit in SCR is cleared to 0. If reception of the next data is completed while the RDRF flag is still set to 1, an overrun error will occur and the receive data will be lost.

**Transmit Data Register Empty**

0	[Clearing conditions] • When 0 is written to TDRE after reading TDRE = 1 • When the DTC is activated by a TXI interrupt and writes data to TDR
1	[Setting conditions] • When the TE bit in SCR is 0 • When data is transferred from TDR to TSR and data can be written to TDR

- Notes:
- \*1 Only 0 can be written, to clear the flag.
  - \*2 If a parity error occurs, the receive data is transferred to RDR but the RDRF flag is not set. Also, subsequent serial reception cannot be continued while the PER flag is set to 1. In clocked synchronous mode, serial transmission cannot be continued, either.
  - \*3 In 2-stop-bit mode, only the first stop bit is checked for a value of 1; the second stop bit is not checked. If a framing error occurs, the receive data is transferred to RDR but the RDRF flag is not set. Serial reception cannot be continued while the FER flag is set to 1. In clocked synchronous mode, serial transmission cannot be continued, either.
  - \*4 The receive data prior to the overrun error is retained in RDR, and the data received subsequently is lost. Serial reception cannot be continued while the ORER flag is set to 1. In clocked synchronous mode, serial transmission cannot be continued either.

**RDR0—Receive Data Register 0****H'FF7D****SCI0****SCMR0—Smart Card Mode Register 0****H'FF7E****SCI0****Selects the Serial/Parallel Conversion Format**

0	TDR contents are transmitted LSB-first Receive data is stored in RDR LSB-first
1	TDR contents are transmitted MSB-first Receive data is stored in RDR MSB-first



Bit	:	7	6	5	4	3	2	1	0
		C/ $\bar{A}$	CHR	PE	O/ $\bar{E}$	STOP	MP	CKS1	CKS0
Initial value :		0	0	0	0	0	0	0	0
R/W	:	R/W	R/W	R/W	R/W	R/W	R/W	R/W	R/W

**Clock Select**

0	0	$\emptyset$ clock
	1	$\emptyset/4$ clock
1	0	$\emptyset/16$ clock
	1	$\emptyset/64$ clock

**Multiprocessor Mode**

0	Multiprocessor function disabled
1	Multiprocessor format selected

**Stop Bit Length**

0	1 stop bit
1	2 stop bits

**Parity Mode**

0	Even parity* <sup>1</sup>
1	Odd parity* <sup>2</sup>

Notes: \*<sup>1</sup> When even parity is set, parity bit addition is performed in transmission so that the total number of 1-bits in the transmit character plus the parity bit is even. In reception, a check is performed to see if the total number of 1-bits in the receive character plus the parity bit is even.

\*<sup>2</sup> When odd parity is set, parity bit addition is performed in transmission so that the total number of 1-bits in the transmit character plus the parity bit is odd. In reception, a check is performed to see if the total number of 1-bits in the receive character plus the parity bit is odd.

**Parity Enable**

0	Parity bit addition and checking disabled
1	Parity bit addition and checking enabled*

Note: \* When the PE bit is set to 1, an even or odd parity bit is added to transmit data according to the even or odd parity mode selection by the O/ $\bar{E}$  bit, and the parity bit in receive data is checked to see if it matches the even or odd mode selected by the O/ $\bar{E}$  bit.

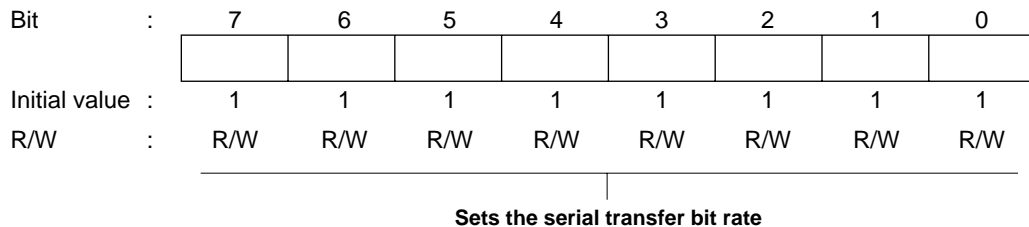
**Character Length**

0	8-bit data
1	7-bit data*

Note: \* When 7-bit data is selected, the MSB (bit 7) of TDR is not transmitted, and it is not possible to choose between LSB-first or MSB-first transfer.

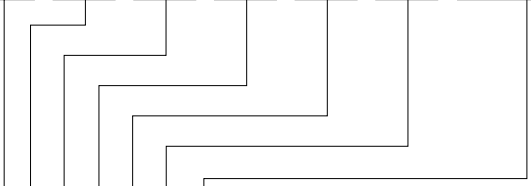
**Selects Asynchronous Mode or Clocked Synchronous Mode**

0	Asynchronous mode
1	Clocked synchronous mode



Note: For details, see section 13.2.8, Bit Rate Register (BRR)

Bit	:	7	6	5	4	3	2	1	0
		TIE	RIE	TE	RE	MPIE	TEIE	CKE1	CKE0
Initial value	:	0	0	0	0	0	0	0	0
R/W	:	R/W	R/W	R/W	R/W	R/W	R/W	R/W	R/W



**Clock Enable**

0	0	Asynchronous mode	Internal clock/SCK pin functions as I/O port
		Clocked synchronous mode	Internal clock/SCK pin functions as serial clock output
1		Asynchronous mode	Internal clock/SCK pin functions as clock output*1
		Clocked synchronous mode	Internal clock/SCK pin functions as serial clock output
1	0	Asynchronous mode	External clock/SCK pin functions as clock input*2
		Clocked synchronous mode	External clock/SCK pin functions as serial clock input
1		Asynchronous mode	External clock/SCK pin functions as clock input*2
		Clocked synchronous mode	External clock/SCK pin functions as serial clock input

**Transmit End Interrupt Enable**

0	Transmit end interrupt (TEI) request disabled*3
1	Transmit end interrupt (TEI) request enabled*3

**Multiprocessor Interrupt Enable**

0	Multiprocessor interrupts disabled [Clearing conditions] • When the MPIE bit is cleared to 0 • When MPB= 1 data is received
1	Multiprocessor interrupts enabled*4 Receive interrupt (RXI) requests, receive error interrupt (ERI) requests, and setting of the RDRF, FER, and ORER flags in SSR are disabled until data with the multiprocessor bit set to 1 is received.

**Receive Enable**

0	Reception disabled*5
1	Reception enabled*6

**Transmit Enable**

0	Transmission disabled*7
1	Transmission enabled*8

**Receive Interrupt Enable**

0	Receive data full interrupt (RXI) request and receive error interrupt (ERI) request disabled*9
1	Receive data full interrupt (RXI) request and receive error interrupt (ERI) request enabled

**Transmit Interrupt Enable**

0	Transmit data empty interrupt (TXI) requests disabled
1	Transmit data empty interrupt (TXI) requests enabled

Note: TXI cancellation can be performed by reading 1 from the TDRE flag, then clearing it to 0, or by clearing the TIE bit to 0.

- Notes:
- \*1 Outputs a clock of the same frequency as the bit rate.
  - \*2 Inputs a clock with a frequency 16 times the bit rate.
  - \*3 TEI cancellation can be performed by reading 1 from the TDRE flag in SSR, then clearing it to 0 and clearing the TEND flag to 0, or by clearing the TEIE bit to 0.
  - \*4 When receive data including MPB = 0 is received, receive data transfer from RSR to RDR, receive error detection, and setting of the RDRF, FER, and ORER flags in SSR, is not performed. When receive data including MPB = 1 is received, the MPB bit in SSR is set to 1, the MPIE bit is cleared to 0 automatically, and generation of RXI and ERI interrupts (when the TIE and RIE bits in SCR are set to 1) and FER and ORER flag setting is enabled.
  - \*5 Clearing the RE bit to 0 does not affect the RDRF, FER, PER, and ORER flags, which retain their states.
  - \*6 Serial reception is started in this state when a start bit is detected in asynchronous mode or serial clock input is detected in clocked synchronous mode. SMR setting must be performed to decide the receive format before setting the RE bit to 1.
  - \*7 The TDRE flag in SSR is fixed at 1.
  - \*8 In this state, serial transmission is started when transmit data is written to TDR and the TDRE flag in SSR is cleared to 0. SMR setting must be performed to decide the transmit format before setting the TE bit to 1.
  - \*9 RXI and ERI cancellation can be performed by reading 1 from the RDRF flag, or the FER, PER, or ORER flag, then clearing the flag to 0, or by clearing the RIE bit to 0.



Bit	7	6	5	4	3	2	1	0
	TDRE	RDRF	ORER	FER	PER	TEND	MPB	MPBT
Initial value :	1	0	0	0	0	1	0	0
R/W :	R/(W)*1	R/(W)*1	R/(W)*1	R/(W)*1	R/(W)*1	R	R	R/W

**Multiprocessor Bit Transfer**

0	[Clearing condition] When data with a 0 multiprocessor bit is transmitted
1	[Setting condition] When data with a 1 multiprocessor bit is transmitted

**Multiprocessor Bit**

0	[Clearing condition] When data with a 0 multiprocessor bit is received
1	[Setting condition] When data with a 1 multiprocessor bit is received

**Transmit End**

0	[Clearing conditions] • When 0 is written to TDRE after reading TDRE = 1 • When the DTC is activated by a TXI interrupt and writes data to TDR
1	[Setting conditions] • When the TE bit in SCR is 0 • When TDRE = 1 at transmission of the last bit of a 1-byte serial transmit character

**Parity Error**

0	[Clearing condition] When 0 is written to PER after reading PER = 1
1	[Setting condition] When, in reception, the number of 1 bits in the receive data plus the parity bit does not match the parity setting (even or odd) specified by the O/E bit in SMR*2

**Framing Error**

0	[Clearing condition] • When 0 is written to FER after reading FER = 1
1	[Setting condition] When the SCI checks whether the stop bit at the end of the receive data when reception ends, and the stop bit is 0*3

**Overrun Error**

0	[Clearing condition] When 0 is written to ORER after reading ORER = 1
1	[Setting condition] When the next serial reception is completed while RDRF = 1*4

**Receive Data Register Full**

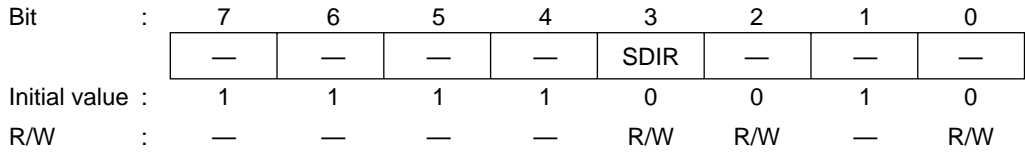
0	[Clearing conditions] • When 0 is written to RDRF after reading RDRF = 1 • When the DTC is activated by an RXI interrupt and reads data from RDR
1	[Setting condition] When serial reception ends normally and receive data is transferred from RSR to RDR

Note: RDR and the RDRF flag are not affected and retain their previous values when an error is detected during reception or when the RE bit in SCR is cleared to 0. If reception of the next data is completed while the RDRF flag is still set to 1, an overrun error will occur and the receive data will be lost.

**Transmit Data Register Empty**

0	[Clearing conditions] • When 0 is written to TDRE after reading TDRE = 1 • When the DTC is activated by a TXI interrupt and writes data to TDR
1	[Setting conditions] • When the TE bit in SCR is 0 • When data is transferred from TDR to TSR and data can be written to TDR

- Notes:
- \*1 Only 0 can be written, to clear the flag.
  - \*2 If a parity error occurs, the receive data is transferred to RDR but the RDRF flag is not set. Also, subsequent serial reception cannot be continued while the PER flag is set to 1. In clocked synchronous mode, serial transmission cannot be continued, either.
  - \*3 In 2-stop-bit mode, only the first stop bit is checked for a value of 1; the second stop bit is not checked. If a framing error occurs, the receive data is transferred to RDR but the RDRF flag is not set. Serial reception cannot be continued while the FER flag is set to 1. In clocked synchronous mode, serial transmission cannot be continued, either.
  - \*4 The receive data prior to the overrun error is retained in RDR, and the data received subsequently is lost. Serial reception cannot be continued while the ORER flag is set to 1. In clocked synchronous mode, serial transmission cannot be continued either.

**RDR1—Receive Data Register 1****H'FF85****SCI1****SCMR1—Smart Card Mode Register 1****H'FF86****SCI1****Reserved**

Only 0 should be written to these bits

**Selects the Serial/Parallel Conversion Format**

0	TDR contents are transmitted LSB-first Receive data is stored in RDR LSB-first
1	TDR contents are transmitted MSB-first Receive data is stored in RDR MSB-first



<b>ADDRAH</b> —A/D Data Register AH	<b>H'FF90</b>	<b>A/D Converter</b>
<b>ADDRAL</b> —A/D Data Register AL	<b>H'FF91</b>	
<b>ADDRBH</b> —A/D Data Register BH	<b>H'FF92</b>	
<b>ADDRBL</b> —A/D Data Register BL	<b>H'FF93</b>	
<b>ADDRCH</b> —A/D Data Register CH	<b>H'FF94</b>	
<b>ADDRCL</b> —A/D Data Register CL	<b>H'FF95</b>	
<b>ADDRDH</b> —A/D Data Register DH	<b>H'FF96</b>	
<b>ADDRDL</b> —A/D Data Register DL	<b>H'FF97</b>	

Bit	:	15	14	13	12	11	10	9	8	7	6	5	4	3	2	1	0
		AD9	AD8	AD7	AD6	AD5	AD4	AD3	AD2	AD1	AD0	—	—	—	—	—	—
Initial value	:	0	0	0	0	0	0	0	0	0	0	0	0	0	0	0	0
R/W	:	R	R	R	R	R	R	R	R	R	R	R	R	R	R	R	R

Store the results of A/D conversion

Analog Input Channel		A/D Data Register
Group 0	Group 1	
AN0	AN4	ADDRA
AN1	AN5	ADDRB
AN2	AN6	ADDRC
AN3	AN7	ADDRD

Bit	:	7	6	5	4	3	2	1	0
		ADF	ADIE	ADST	SCAN	—	CH2	CH1	CH0
Initial value	:	0	0	0	0	0	0	0	0
R/W	:	R/(W)*	R/W	R/W	R/W	R/W	R/W	R/W	R/W

**Channel Select**

Group Selection	Channel Selection		Description	
	CH2	CH1 CH0	Single Mode	Scan Mode
0	0	0	AN0 (Initial value)	AN0
		1	AN1	AN0, AN1
	1	0	AN2	AN0 to AN2
		1	AN3	AN0 to AN3
1	0	0	AN4	AN4
		1	AN5	AN4, AN5
	1	0	AN6	AN4 to AN6
		1	AN7	AN4 to AN7

**Reserved**  
Only 0 should be written to this bit

**Scan Mode**

0	Single mode
1	Scan mode

**A/D Start**

0	• A/D conversion stopped
1	• Single mode: A/D conversion is started. Cleared to 0 automatically when conversion on the specified channel ends • Scan mode: A/D conversion is started. Conversion continues sequentially on the selected channels until ADST is cleared to 0 by software, a reset, or a transition to standby mode or module stop mode.

**A/D Interrupt Enable**

0	A/D conversion end interrupt (ADI) request disabled
1	A/D conversion end interrupt (ADI) request enabled

**A/D End Flag**

0	[Clearing conditions] • When 0 is written to the ADF flag after reading ADF = 1 • When the DTC is activated by an ADI interrupt and ADDR is read
1	[Setting conditions] • Single mode: When A/D conversion ends • Scan mode: When A/D conversion ends on all specified channels

Note: \* Only 0 can be written, to clear this flag.

Bit	:	7	6	5	4	3	2	1	0
		TRGS1	TRGS0	—	—	CKS1	CKS0	—	—
Initial value	:	0	0	1	1	0	0	1	1
R/W	:	R/W	R/W	—	—	R/W	R/W	—	—

**Clock Select**

CKS1	CKS0	Description
0	0	Conversion time = 530 states (max.)
	1	Conversion time = 260 states (max.)
1	0	Conversion time = 134 states (max.)
	1	Conversion time = 68 states (max.)

**Timer Trigger Select**

0	0	A/D conversion start by software is enabled
	1	A/D conversion start by TPU conversion start trigger is enabled
1	0	A/D conversion start by 8-bit timer conversion start trigger is enabled
	1	A/D conversion start by external trigger pin (ADTRG) is enabled

Bit	:	7	6	5	4	3	2	1	0
		OVF	WT/IT	TME	PSS	RST/NMI	CKS2	CKS1	CKS0
Initial value :		0	0	0	0	0	0	0	0
R/W	:	R/(W)*1	R/W	R/W	R/W	R/W	R/W	R/W	R/W

**Clock Select**

PSS	CKS2	CKS1	CKS0	Clock	Overflow Period
0	0	0	0	$\phi/2$	51.2 $\mu\text{s}^{*1}$
			1	$\phi/64$	1.6 $\text{ms}^{*1}$
		1	0	$\phi/128$	3.2 $\text{ms}^{*1}$
	1	0	1	$\phi/512$	13.2 $\text{ms}^{*1}$
			0	$\phi/2048$	52.4 $\text{ms}^{*1}$
		1	0	$\phi/8192$	209.8 $\text{ms}^{*1}$
1	0	0	0	$\phi\text{SUB}/2$	6.7 $\text{ms}^{*2}$
			1	$\phi\text{SUB}/4$	13.3 $\text{ms}^{*2}$
		1	0	$\phi\text{SUB}/8$	26.7 $\text{ms}^{*2}$
	1	0	1	$\phi\text{SUB}/16$	53.3 $\text{ms}^{*2}$
			0	$\phi\text{SUB}/32$	106.7 $\text{ms}^{*2}$
		1	0	$\phi\text{SUB}/64$	213.3 $\text{ms}^{*2}$
1	0	0	$\phi\text{SUB}/128$	426.7 $\text{ms}^{*2}$	
		1	$\phi\text{SUB}/256$	853.3 $\text{ms}^{*2}$	

Notes: \*1 The time from TCNT starting to count up from H'00 until it overflows, when  $\phi = 10$  MHz.

\*2 The time from TCNT starting to count up from H'00 until it overflows, when  $\phi\text{SUB} = 76.8$  kHz.

\*3 The time from TCNT starting to count up from H'00 until it overflows, when  $\phi\text{SUB} = 160$  kHz.

**Power-on Reset or NMI**

0	An NMI interrupt is requested
1	A power-on reset is requested

**Prescaler Select**

0	TCNT counts $\phi$ -based prescaler (PSM) divided clock pulses
1	TCNT counts $\phi\text{SUB}$ -based prescaler (PSS) divided clock pulses

**Timer Enable**

0	TCNT is initialized to H'00 and count operation is halted
1	TCNT counts

**Timer Mode Select**

0	Interval timer mode: Interval timer interrupt (WOVI) request is sent to CPU when TCNT overflows
1	Watchdog timer mode: Power-on reset or NMI interrupt request is sent to CPU when TCNT overflows

**Overflow Flag**

0	[Clearing conditions] • Write 0 in the TME bit • Read TCSR when OVF = 1, then write 0 in OVF*2
1	[Setting condition] When TCNT overflows (changes from H'FF to H'00) When internal reset request generation is selected in watchdog timer mode, OVF is cleared automatically by the interval reset.

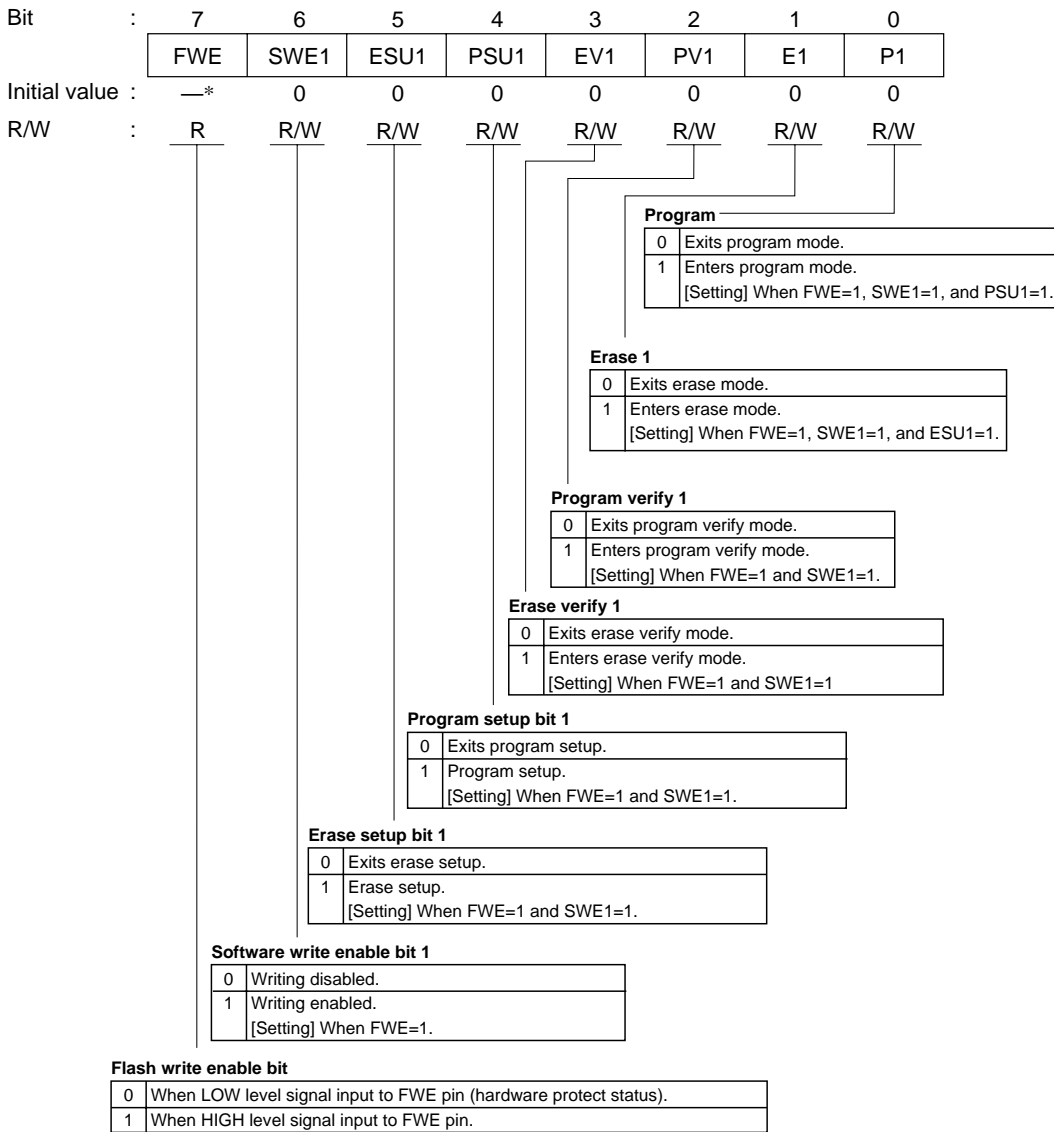
Notes: \*1 Only 0 can be written to clear the flag.

\*2 When the OVF flag is polled with the interval timer interrupt disabled, read the OVF bit while it is 1 at least twice.

TCSR is write-protected by a password to prevent accidental overwriting.

For details see section 12.2.5, Notes on Register Access.

Bit	:	7	6	5	4	3	2	1	0
Initial value	:	0	0	0	0	0	0	0	0
R/W	:	R/W	R/W	R/W	R/W	R/W	R/W	R/W	R/W



Note: \* Determined by the state of pin FWE.

Bit	:	7	6	5	4	3	2	1	0
		FLER	—	—	—	—	—	—	—
Initial value	:	0	0	0	0	0	0	0	0
R/W	:	R	R	R	R	R	R	R	R

**Flash memory error**

0	Flash memory operating normally. Flash memory protection against writing and erasing (error protection) is ignored. [Clearing] At a power-on reset and in hardware standby mode.
1	Shows that an error has occurred when writing to or erasing flash memory. Flash memory protection against writing and erasing (error protection) is enabled. [Setting] See “17.10.3 Error Protection.”

**EBR1—Erase Block Register 1****H'FFAA****FLASH**

Bit	:	7	6	5	4	3	2	1	0
		EB7	EB6	EB5	EB4	EB3	EB2	EB1	EB0
Initial value	:	0	0	0	0	0	0	0	0
R/W	:	R/W	R/W	R/W	R/W	R/W	R/W	R/W	R/W

**EBR2—Erase Block Register 2****H'FFAB****FLASH**

Bit	:	7	6	5	4	3	2	1	0
		—	—	—	—	—	—	EB9	EB8
Initial value	:	0	0	0	0	0	0	0	0
R/W	:	R/W	R/W	R/W	R/W	R/W	R/W	R/W	R/W

**FLPWCR—Flash Memory Power Control Register****H'FFAC****FLASH**

Bit	:	7	6	5	4	3	2	1	0
		PDWND	—	—	—	—	—	—	—
Initial value	:	0	0	0	0	0	0	0	0
R/W	:	R/W	R	R	R	R	R	R	R

**Power down disable**

0	Transition to flash memory power-down mode enabled
1	Transition to flash memory power-down mode disabled

Note: PDWND is enabled in subactive mode or subsleep mode.  
It is disabled in other mode.

**PORT1—Port 1 Register****H'FFB0****Port 1**

Bit	:	7	6	5	4	3	2	1	0
		—	P16	—	P14	P13	P12	P11	P10
Initial value	:	Undefined	—*	Undefined	—*	—*	—*	—*	—*
R/W	:	—	R	—	R	R	R	R	R

**State of port 1 pins**

Note: \* Determined by the state of pins P16, P14 to P10.

**PORT3—Port 3 Register****H'FFB2****Port 3**

Bit	:	7	6	5	4	3	2	1	0
		—	—	P35	P34	P33	P32	P31	P30
Initial value	:	Undefined	Undefined	—*	—*	—*	—*	—*	—*
R/W	:	—	R	R	R	R	R	R	R

**State of port 3 pins**

Note: \* Determined by the state of pins P35 to P30.

**PORT4—Port 4 Register****H'FFB3****Port 4**

Bit	:	7	6	5	4	3	2	1	0
		P47	P46	P45	P44	P43	P42	P41	P40
Initial value	:	—*	—*	—*	—*	—*	—*	—*	—*
R/W	:	R	R	R	R	R	R	R	R

**State of port 4 pins**

Note: \* Determined by the state of pins P47 to P40.



**PORT7—Port 7 Register****H'FFB6****Port 7**

Bit	:	7	6	5	4	3	2	1	0
		—	P76	—	—	—	—	—	—
Initial value	:	Undefined	—*	Undefined	Undefined	Undefined	Undefined	Undefined	Undefined
R/W	:	R	R	R	R	R	—	—	—

|  
**State of MISO for FLEX™ decoder II**

Note: \* Determined by the state of MISO for FLEX™ decoder II.

**PORTA—Port A Register****H'FFB9****Port A**

Bit	:	7	6	5	4	3	2	1	0
		—	—	—	—	PA3	PA2	PA1	PA0
Initial value	:	Undefined	Undefined	Undefined	Undefined	—*	—*	—*	—*
R/W	:	—	—	—	—	R	R	R	R

|  
**State of port A pins**

Note: \* Determined by the state of pins PA3 to PA0.

**PORTB—Port B Register****H'FFBA****Port B**

Bit	:	7	6	5	4	3	2	1	0
		PB7	PB6	PB5	PB4	PB3	PB2	PB1	PB0
Initial value	:	—*	—*	—*	—*	—*	—*	—*	—*
R/W	:	R	R	R	R	R	R	R	R

|  
**State of port B pins**

Note: \* Determined by the state of pins PB7 to PB0.

**PORTC—Port C Register****H'FFBB****Port C**

Bit	:	7	6	5	4	3	2	1	0
		PC7	PC6	PC5	PC4	PC3	PC2	PC1	PC0
Initial value	:	—*	—*	—*	—*	—*	—*	—*	—*
R/W	:	R	R	R	R	R	R	R	R

|  
**State of port C pins**

Note: \* Determined by the state of pins PC7 to PC0.

**PORTD—Port D Register****H'FFBC****Port D**

Bit	:	7	6	5	4	3	2	1	0
		PD7	PD6	PD5	PD4	PD3	PD2	PD1	PD0
Initial value	:	—*	—*	—*	—*	—*	—*	—*	—*
R/W	:	R	R	R	R	R	R	R	R

|  
State of port D pins

Note: \* Determined by the state of pins PD7 to PD0.

**PORTE—Port E Register****H'FFBD****Port E**

Bit	:	7	6	5	4	3	2	1	0
		PE7	PE6	PE5	PE4	PE3	PE2	PE1	PE0
Initial value	:	—*	—*	—*	—*	—*	—*	—*	—*
R/W	:	R	R	R	R	R	R	R	R

|  
State of port E pins

Note: \* Determined by the state of pins PE7 to PE0.

**PORTF—Port F Register****H'FFBE****Port F**

Bit	:	7	6	5	4	3	2	1	0
		PF7	PF6	PF5	PF4	PF3	PF2	PF1	PF0
Initial value	:	—*	—*	—*	—*	—*	—*	—*	—*
R/W	:	R	R	R	R	R	R	R	R

|  
State of port F pins

Note: \* Determined by the state of pins PF7 to PF0.

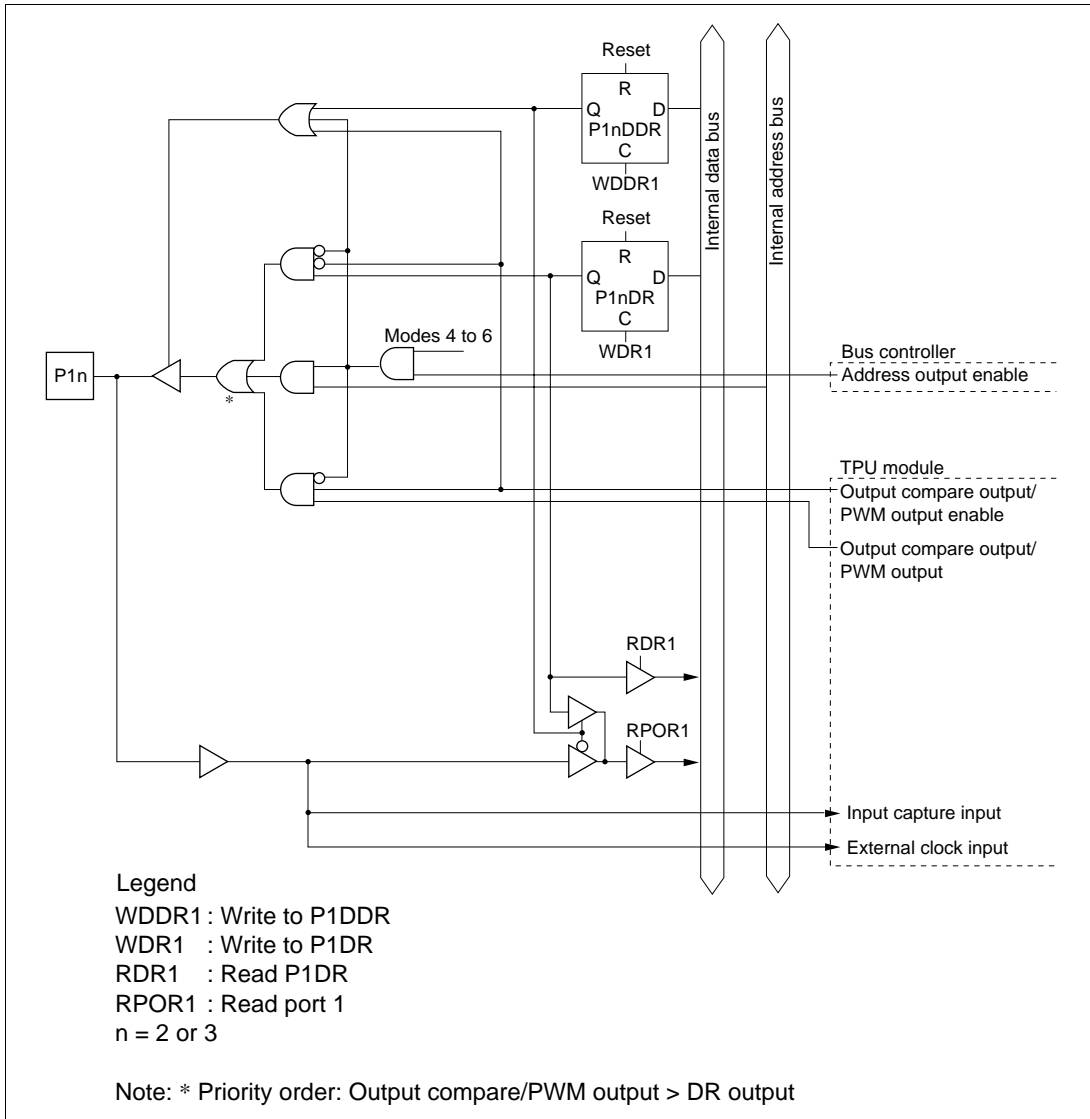
**PORTG—Port G Register****H'FFBF****Port G**

Bit	:	7	6	5	4	3	2	1	0
		—	—	—	PG4	PG3	PG2	PG1	PG0
Initial value	:	Undefined	Undefined	Undefined	—*	—*	—*	—*	—*
R/W	:	—	—	—	R	R	R	R	R

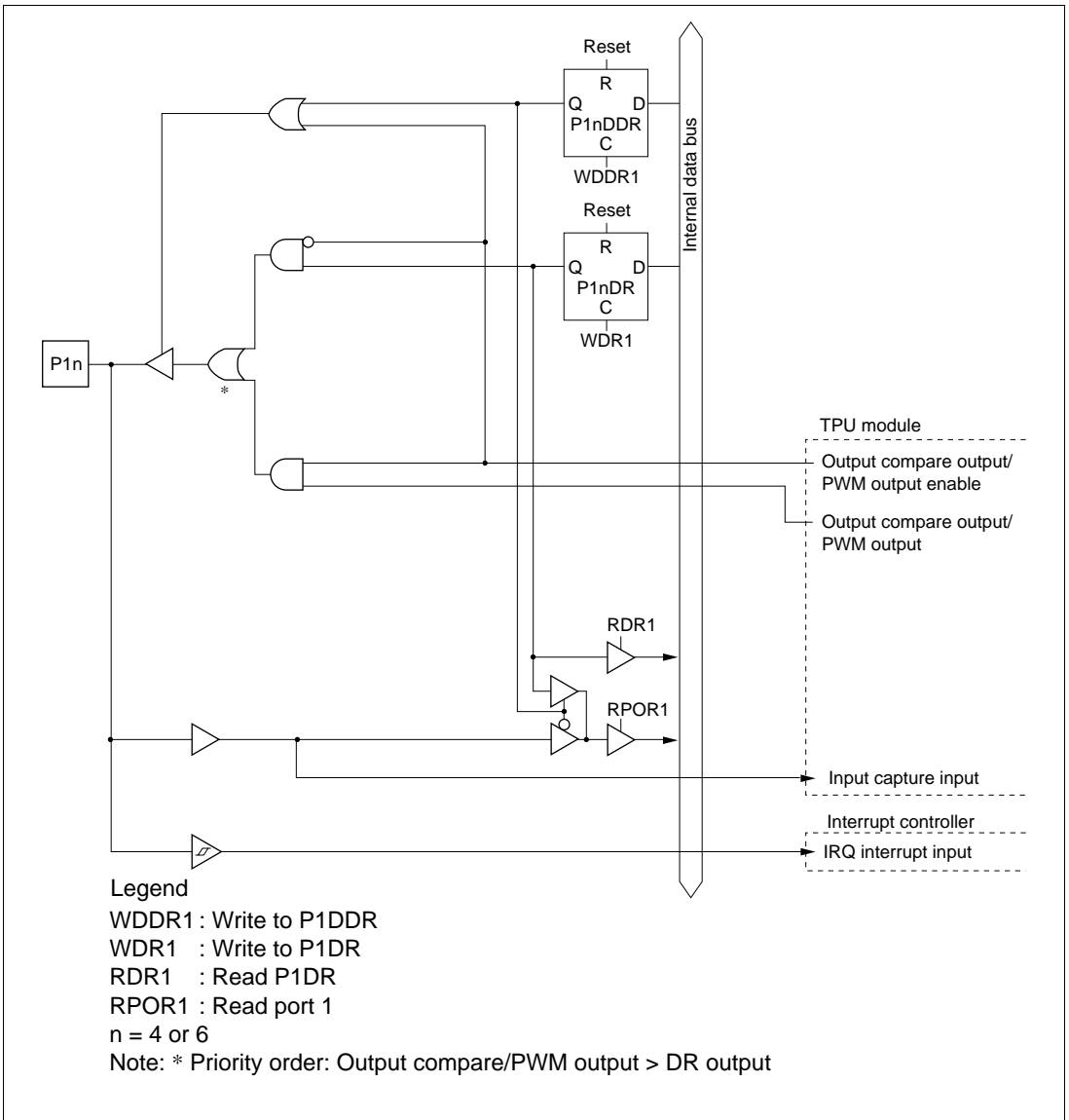
|  
State of port G pins and  $\overline{\text{READY}}$  for FLEX™ decoder II

Note: \* Determined by the state of pins PG4 to PG1 and  $\overline{\text{READY}}$  for FLEX™ decoder II.



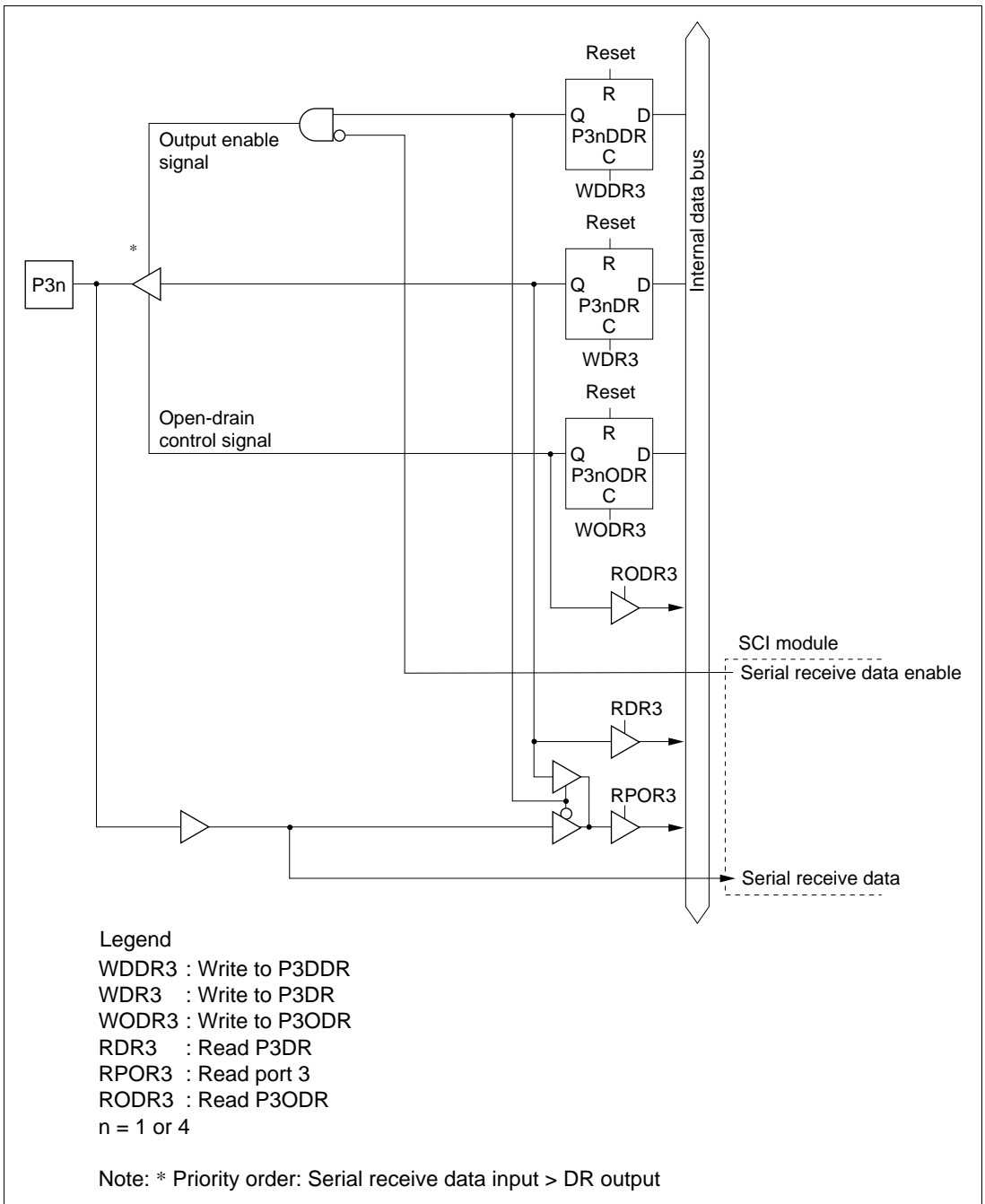


**Figure C.1 (b) Port 1 Block Diagram (Pins P12 and P13)**

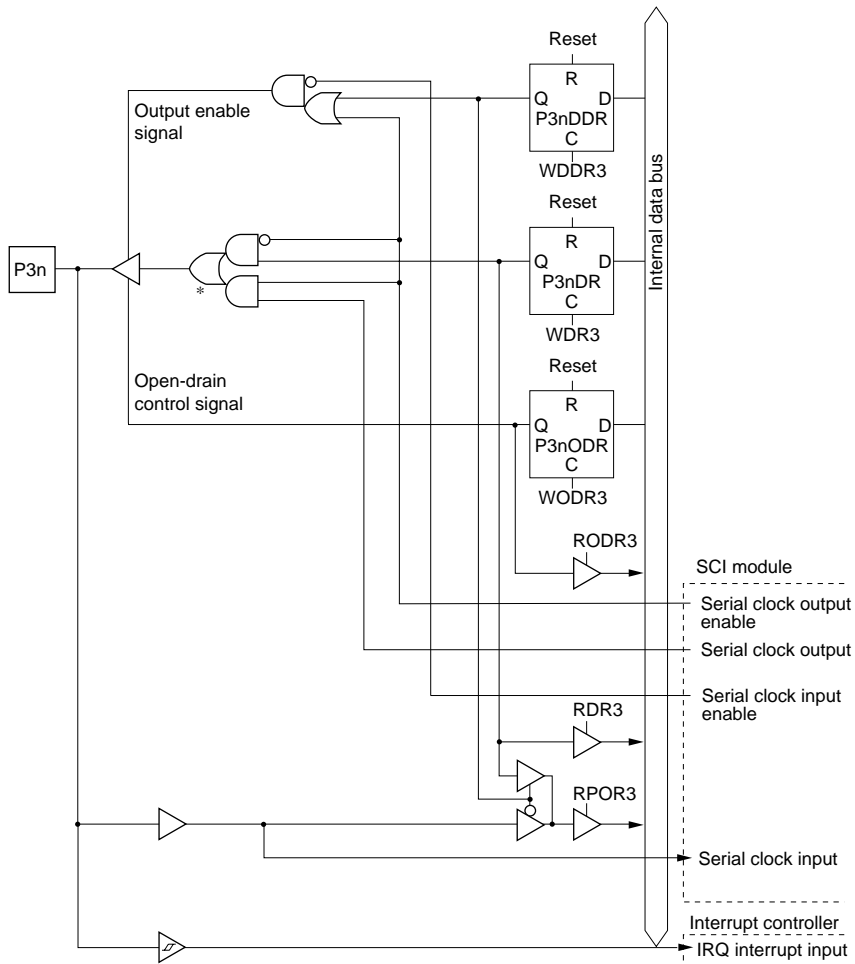


**Figure C.1 (c) Port 1 Block Diagram (Pins P14 and P16)**





**Figure C.2 (b) Port 3 Block Diagram (Pins P31 and P34)**



Legend

WDDR3 : Write to P3DDR

WDR3 : Write to P3DR

WODR3 : Write to P3ODR

RDR3 : Read P3DR

RPOR3 : Read port 3

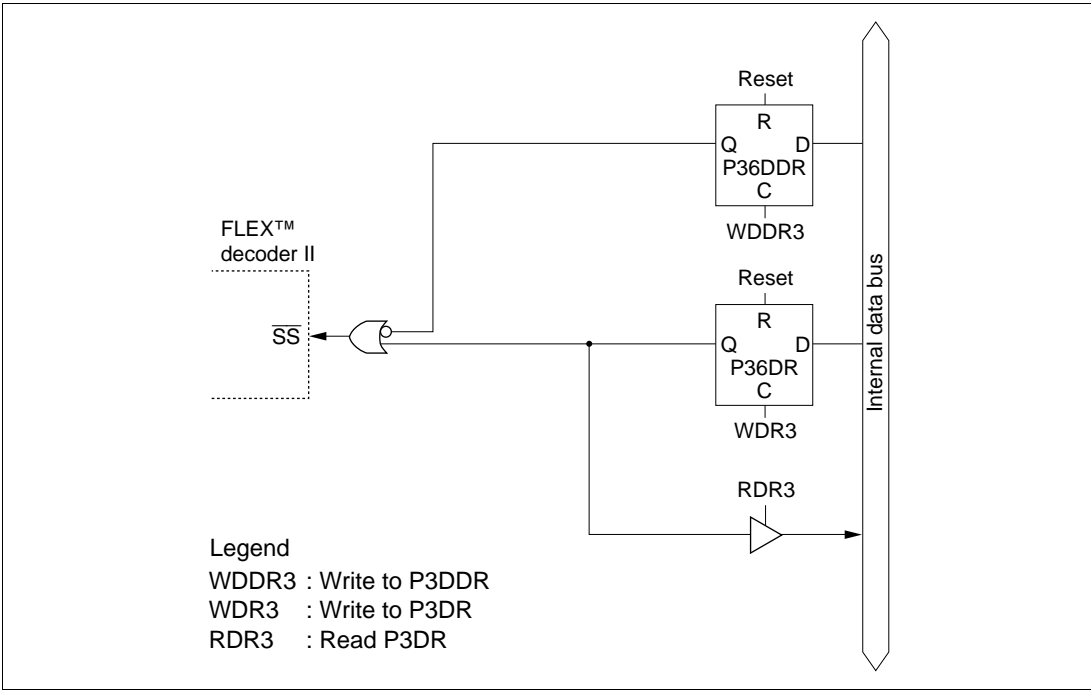
RODR3 : Read P3ODR

n = 2 or 5

Note: \* Priority order: Serial clock input > Serial clock output > DR output

**Figure C.2 (c) Port 3 Block Diagram (Pins P32 and P35)**





**Figure C.2 (d) Port 3 Block Diagram (Pin P36)**

### C.3 Port 4 Block Diagram

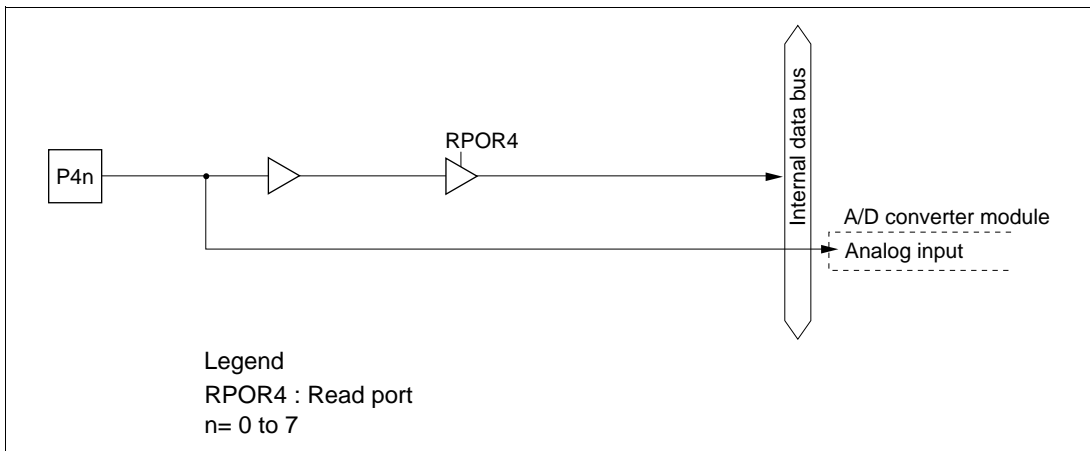


Figure C.3 Port 4 Block Diagram (Pins P40 to P47)

## C.4 Port 7 Block Diagrams

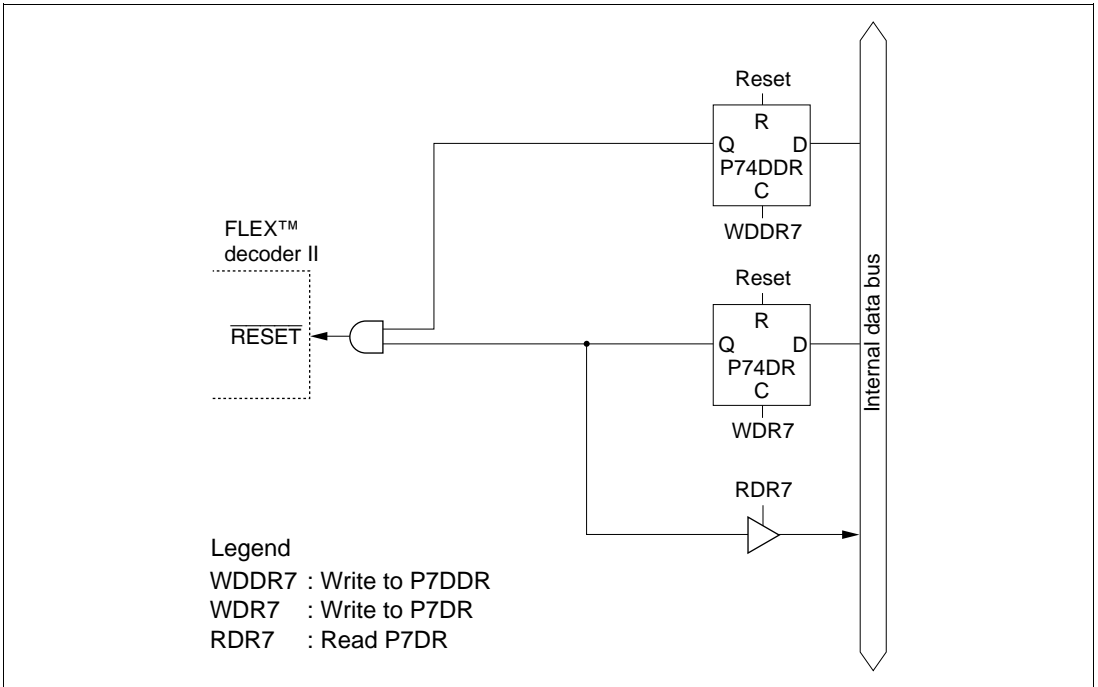
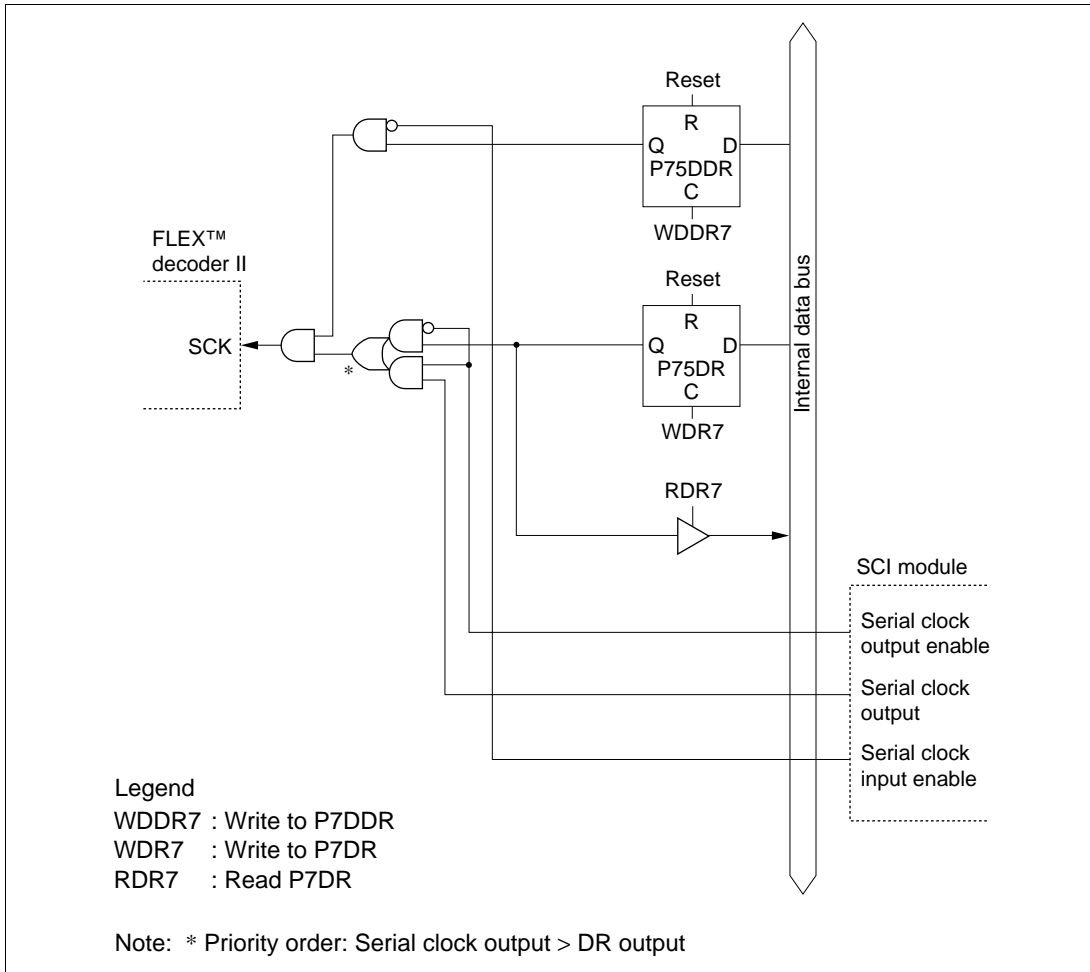
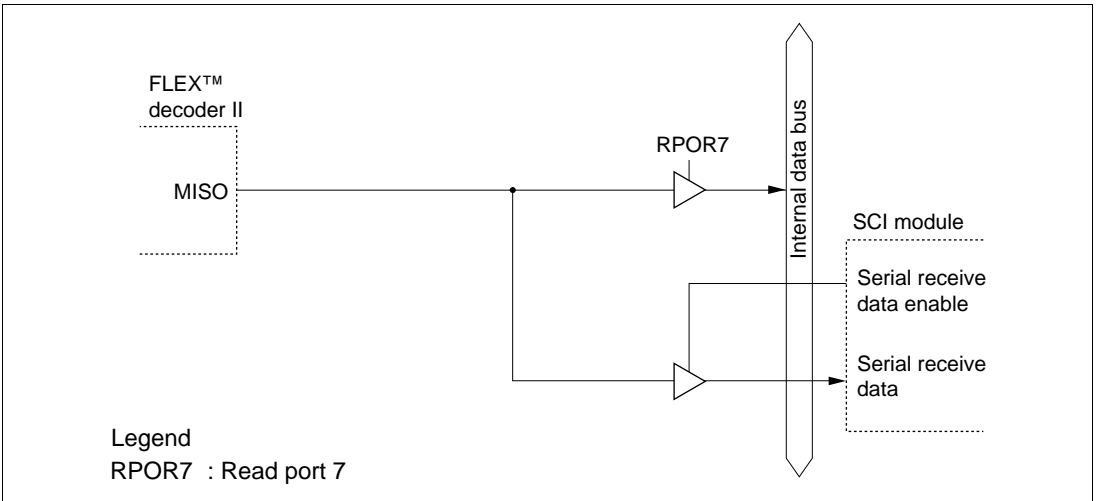


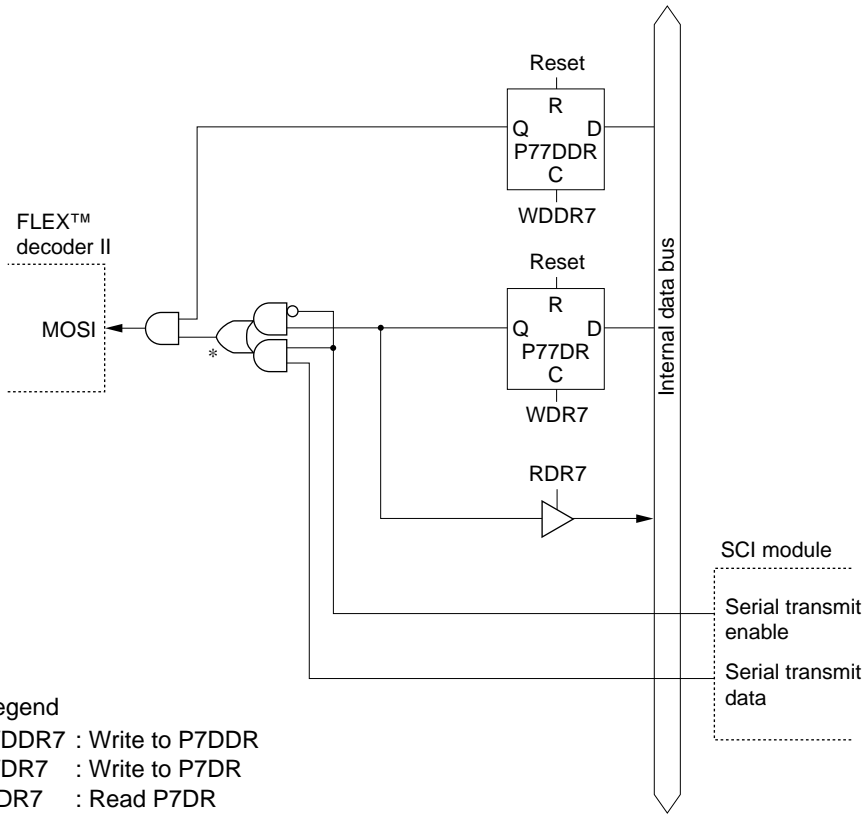
Figure C.4 (a) Port 7 Block Diagram (Pin P74)



**Figure C.4 (b) Port 7 Block Diagram (Pin P75)**



**Figure C.4 (c) Port 7 Block Diagram (Pin P76)**



Legend  
 WDDR7 : Write to P7DDR  
 WDR7 : Write to P7DR  
 RDR7 : Read P7DR

Note: \* Priority order: Serial transmit data output > DR output

Figure C.4 (d) Port 7 Block Diagram (Pin P77)

## C.5 Port A Block Diagrams

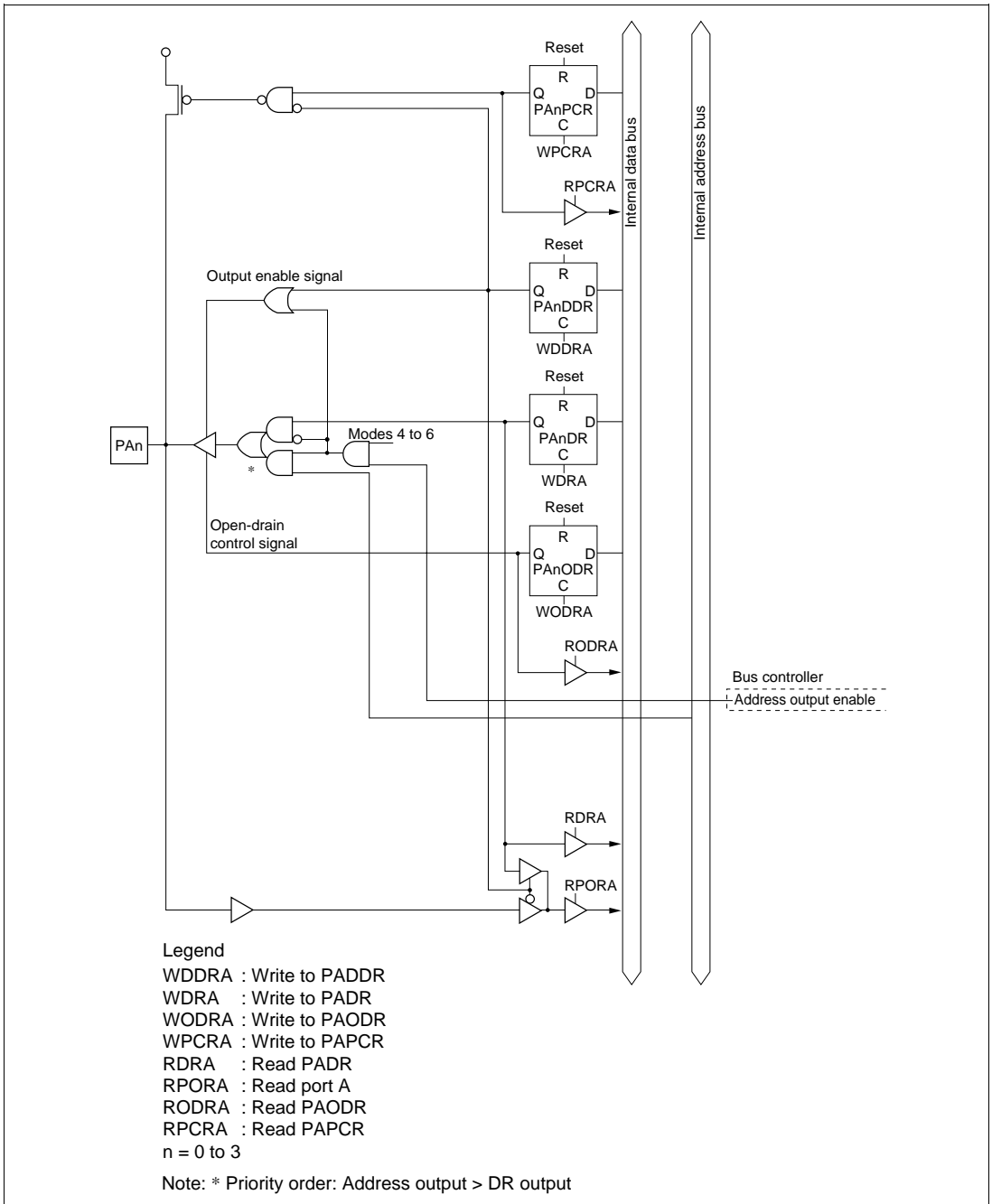


Figure C.5 Port A Block Diagram (Pins PA0 and PA3)

## C.6 Port B Block Diagram

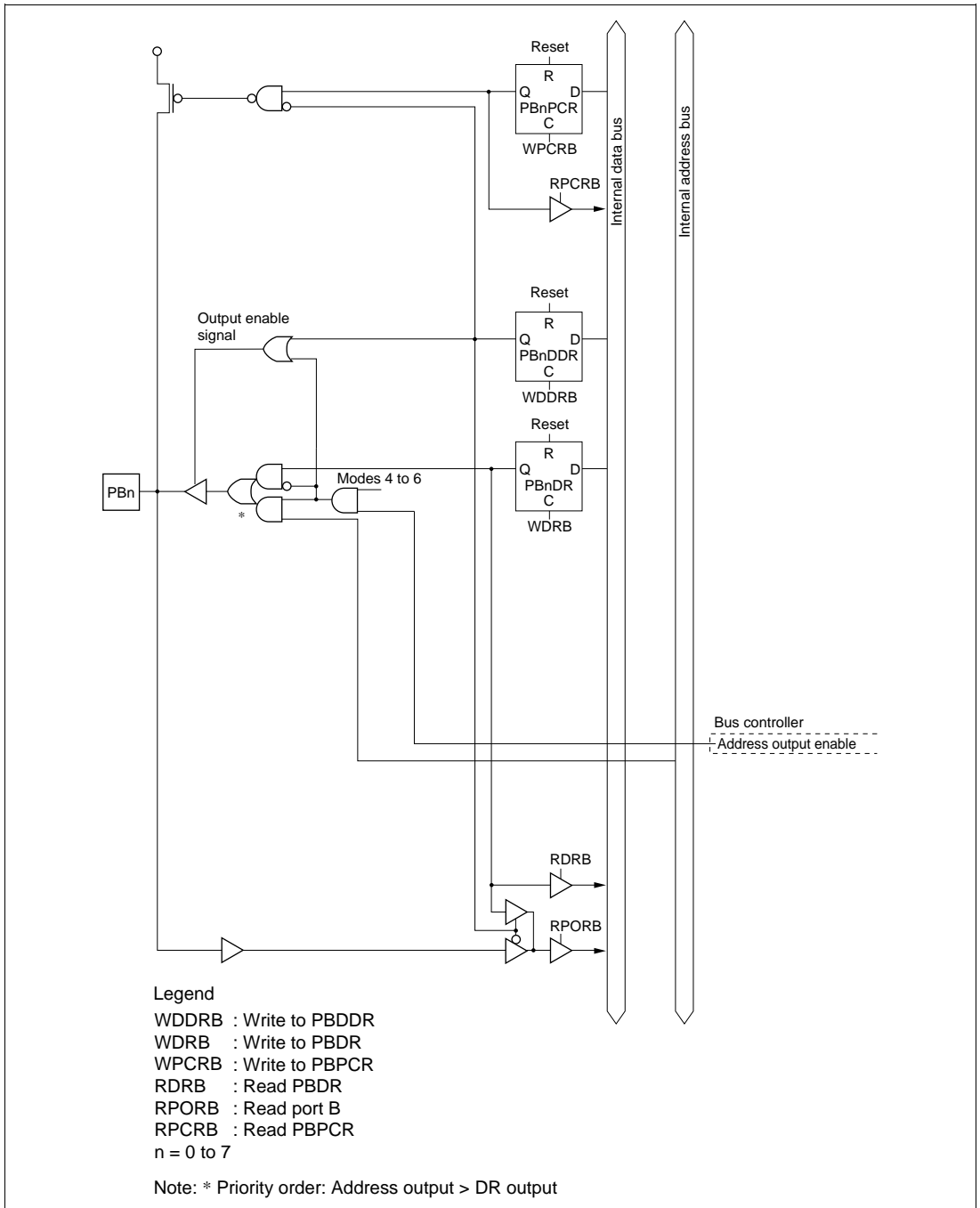


Figure C.6 Port B Block Diagram (Pins PB0 to PB7)



## C.7 Port C Block Diagram

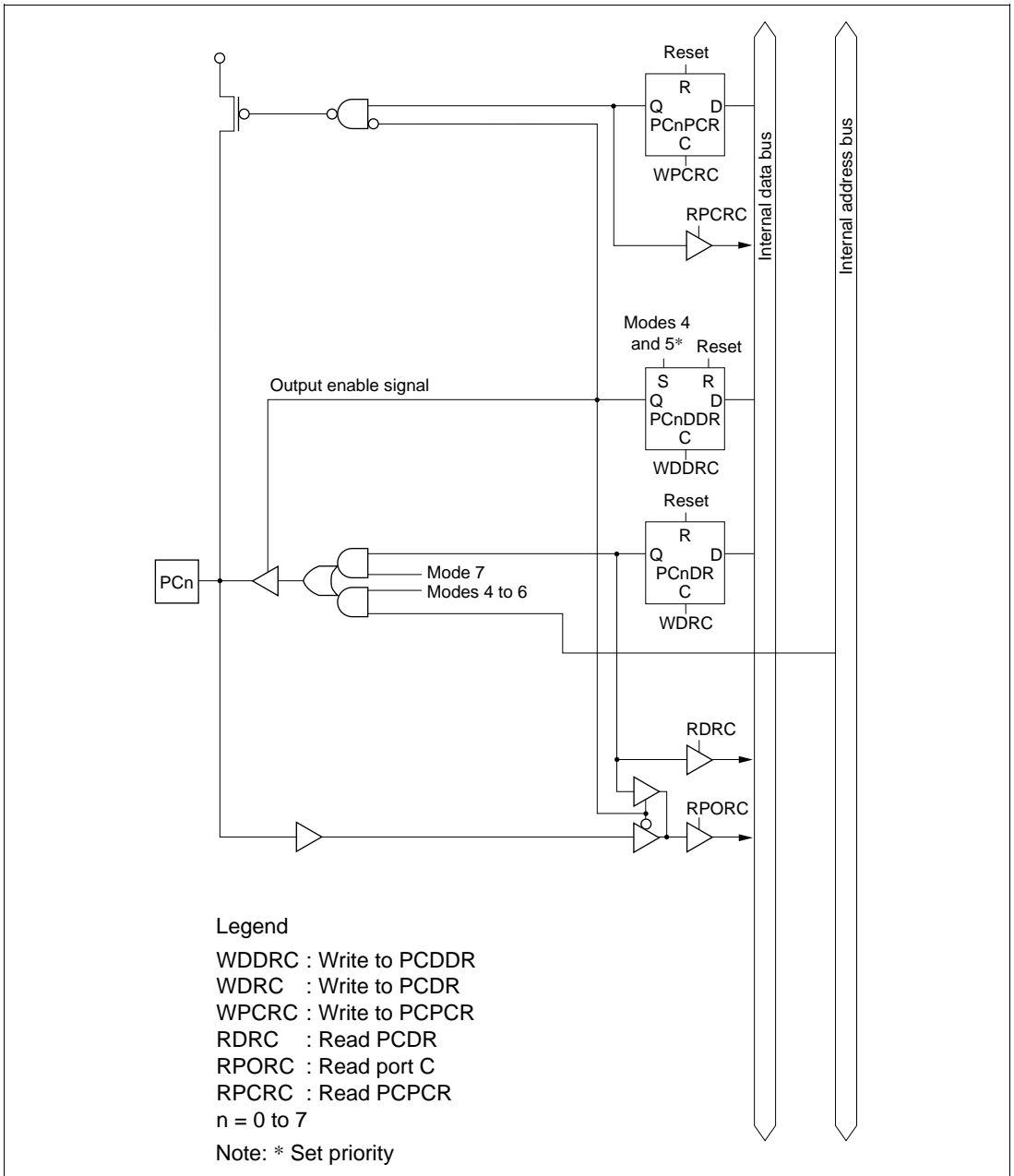


Figure C.7 Port C Block Diagram (Pins PC0 to PC7)

## C.8 Port D Block Diagram

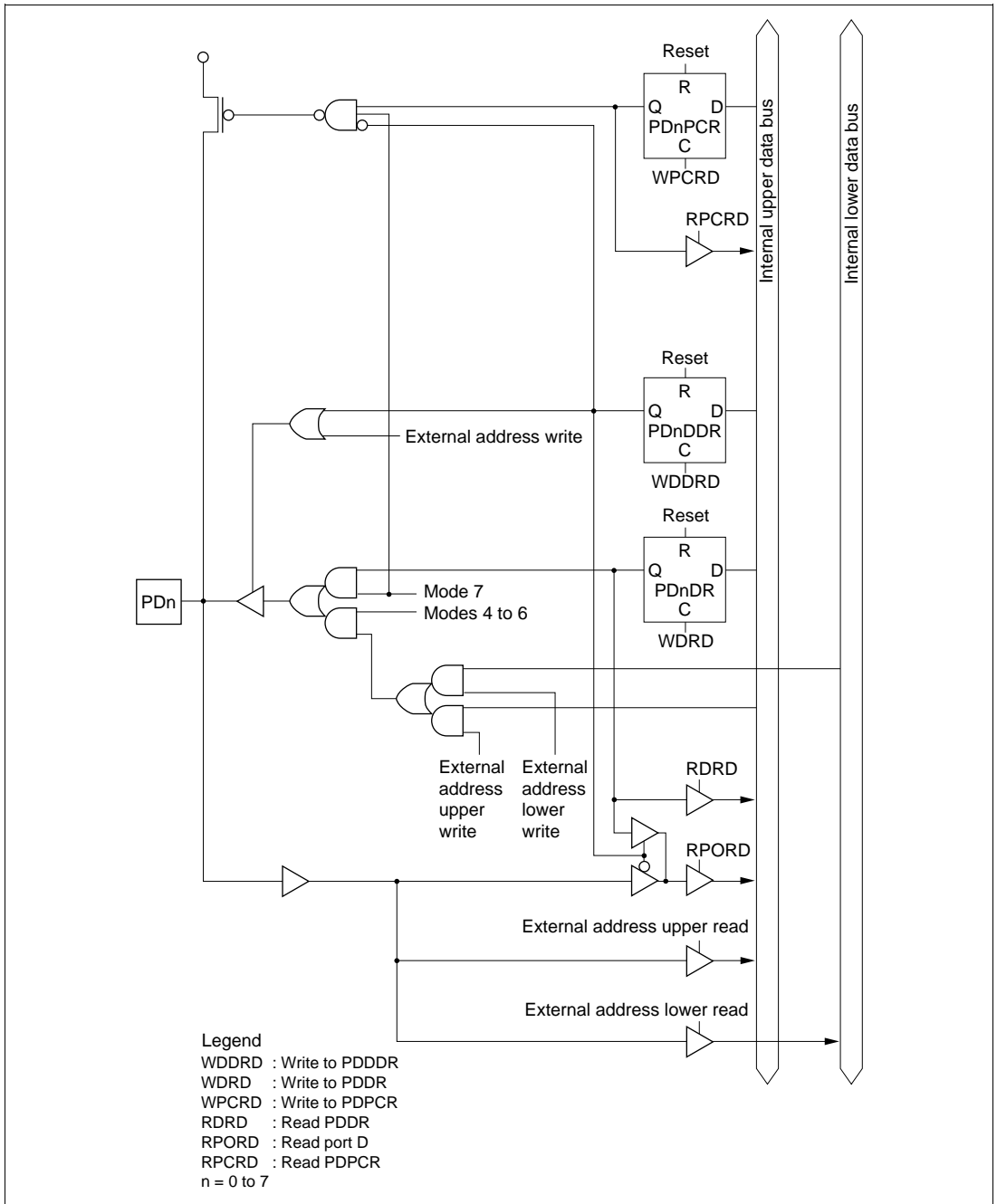


Figure C.8 Port D Block Diagram (Pins PD0 to PD7)

## C.9 Port E Block Diagram

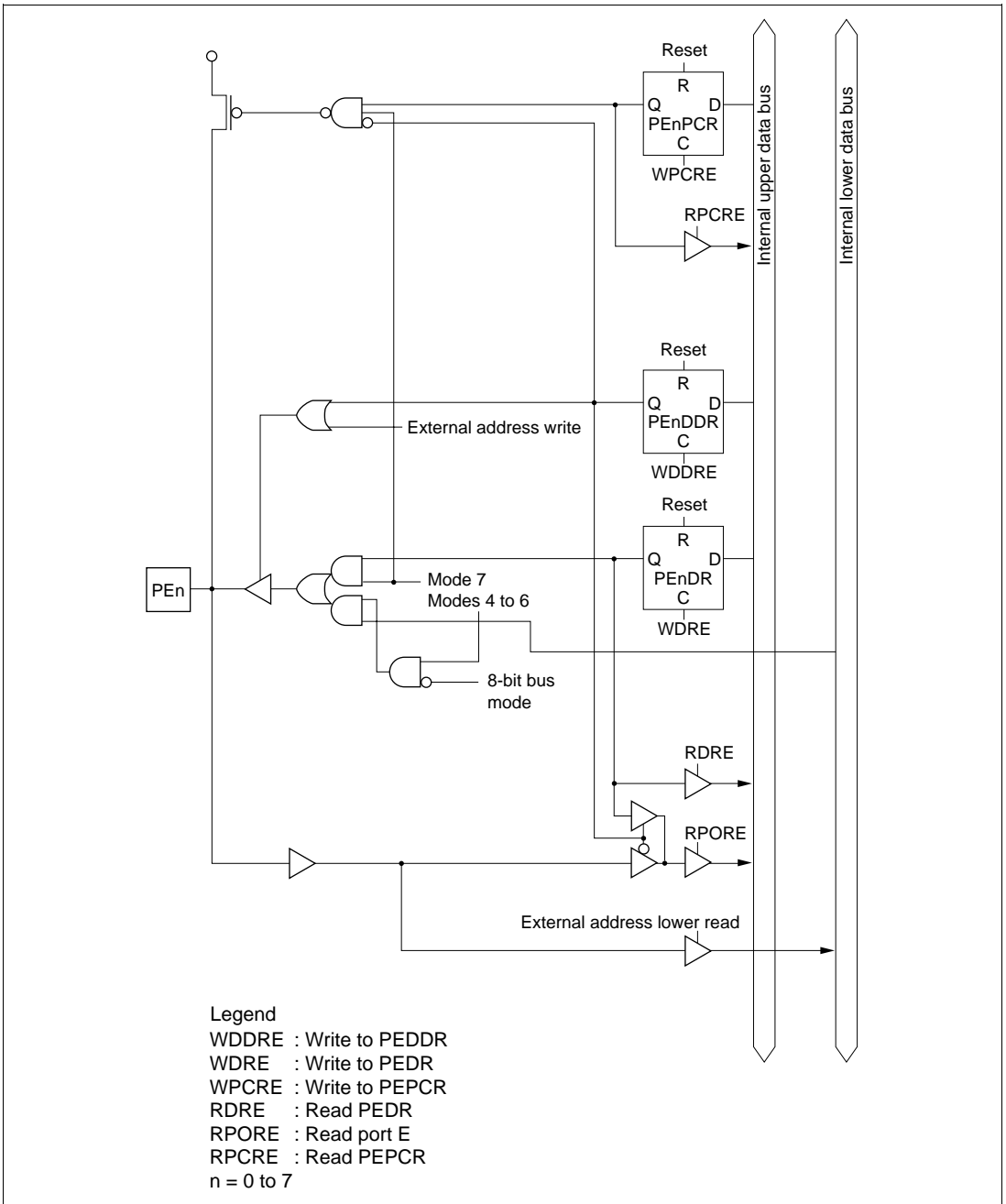


Figure C.9 Port E Block Diagram (Pins PE0 to PE7)

## C.10 Port F Block Diagrams

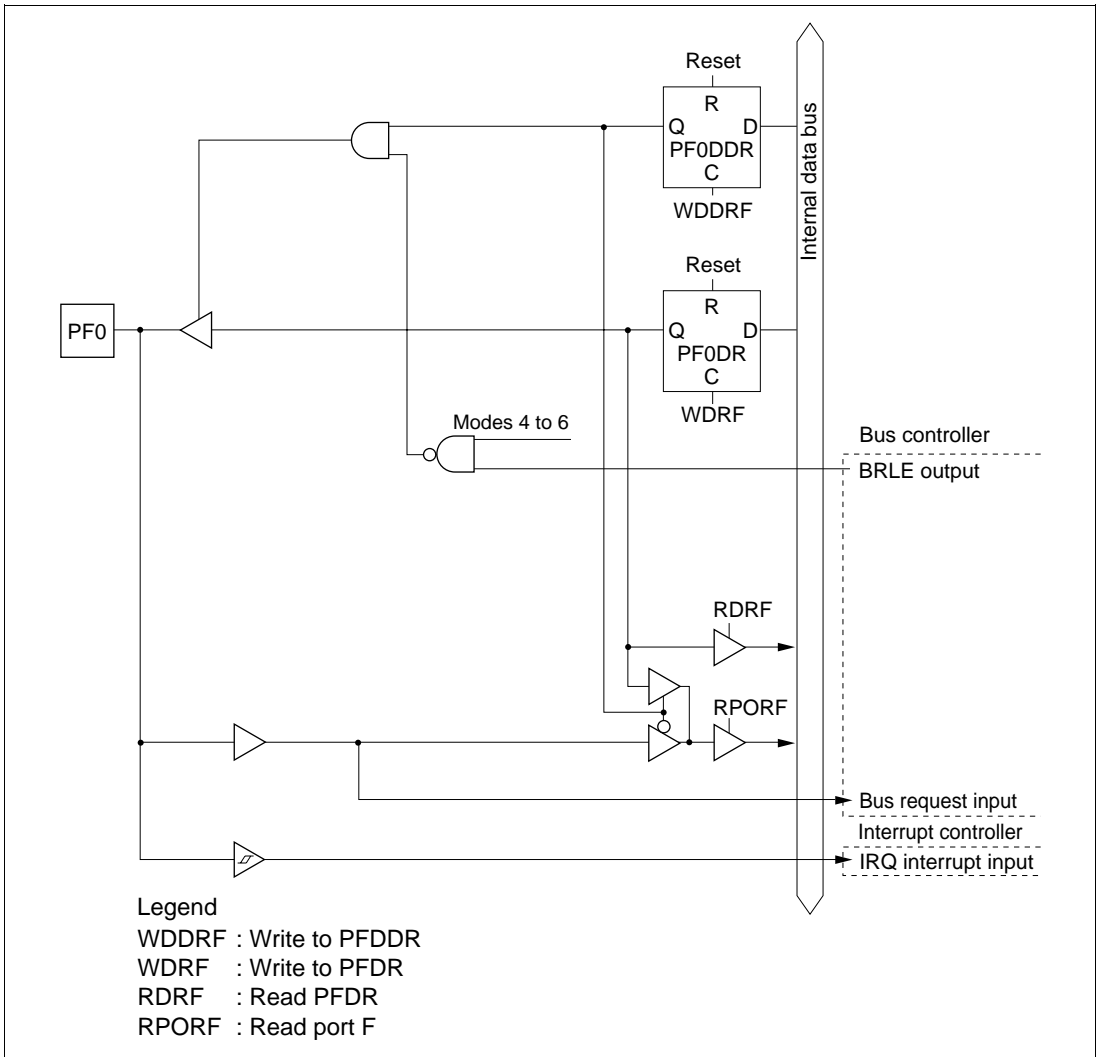
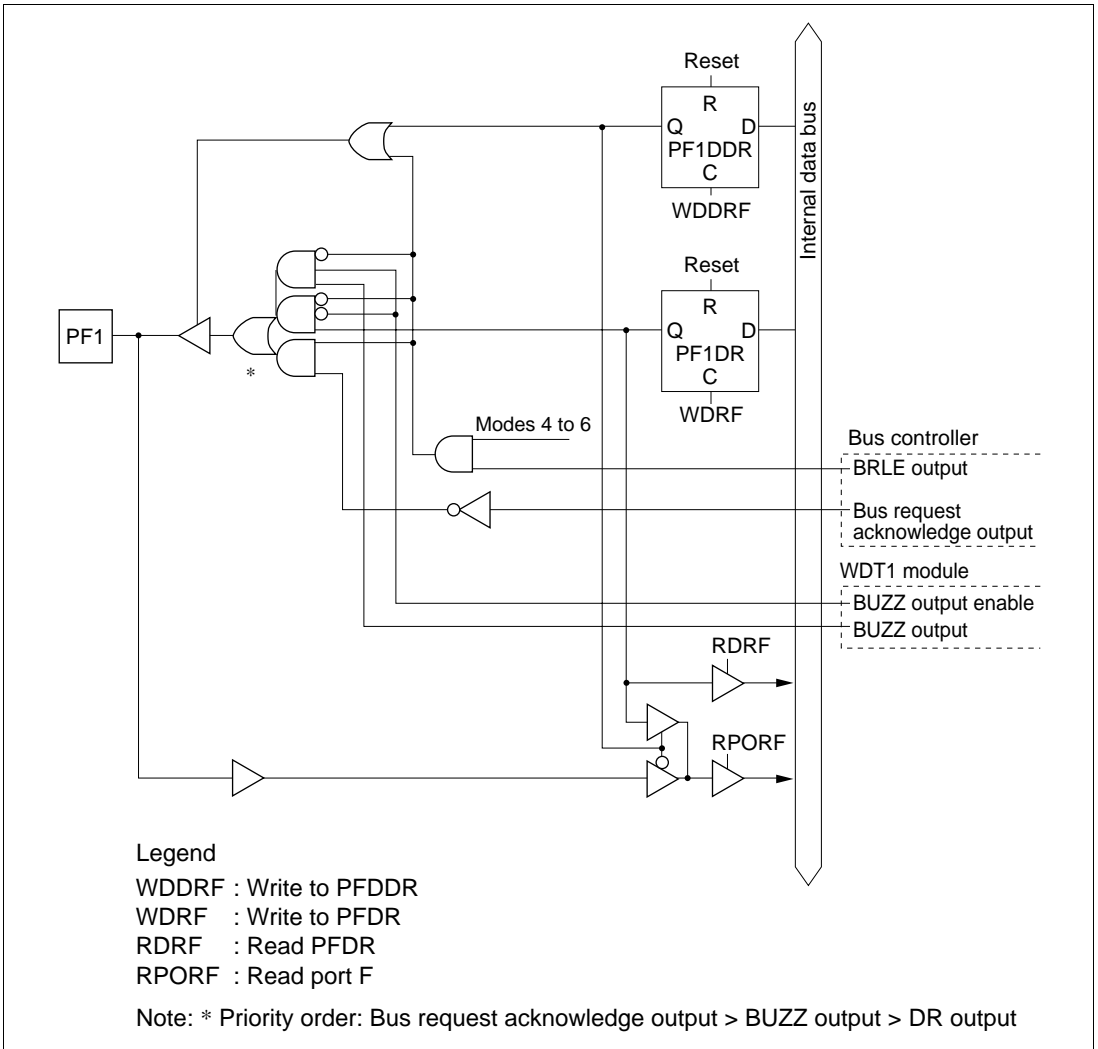
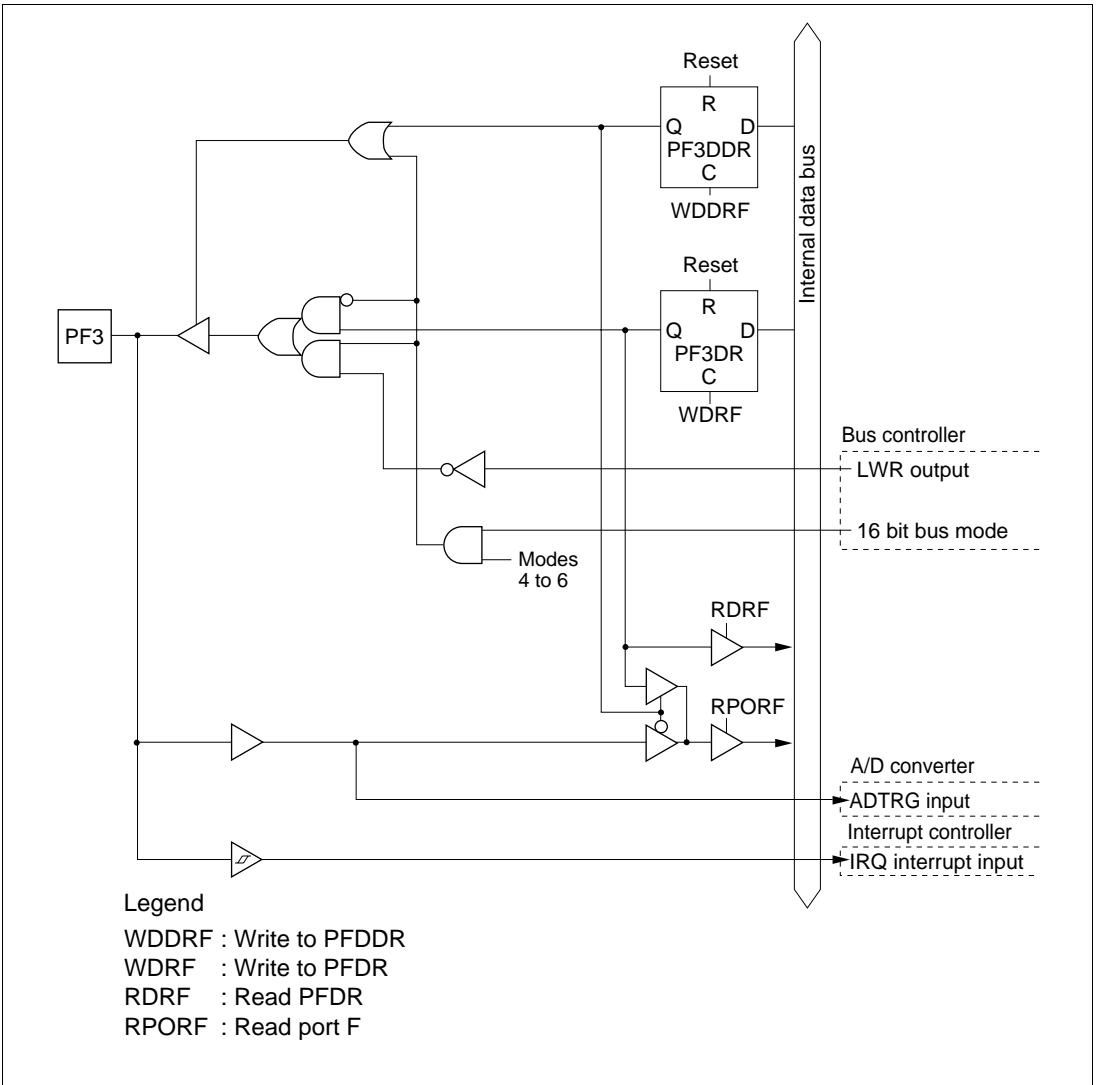


Figure C.10 (a) Port F Block Diagram (Pin PF0)



**Figure C.10 (b) Port F Block Diagram (Pin PF1)**

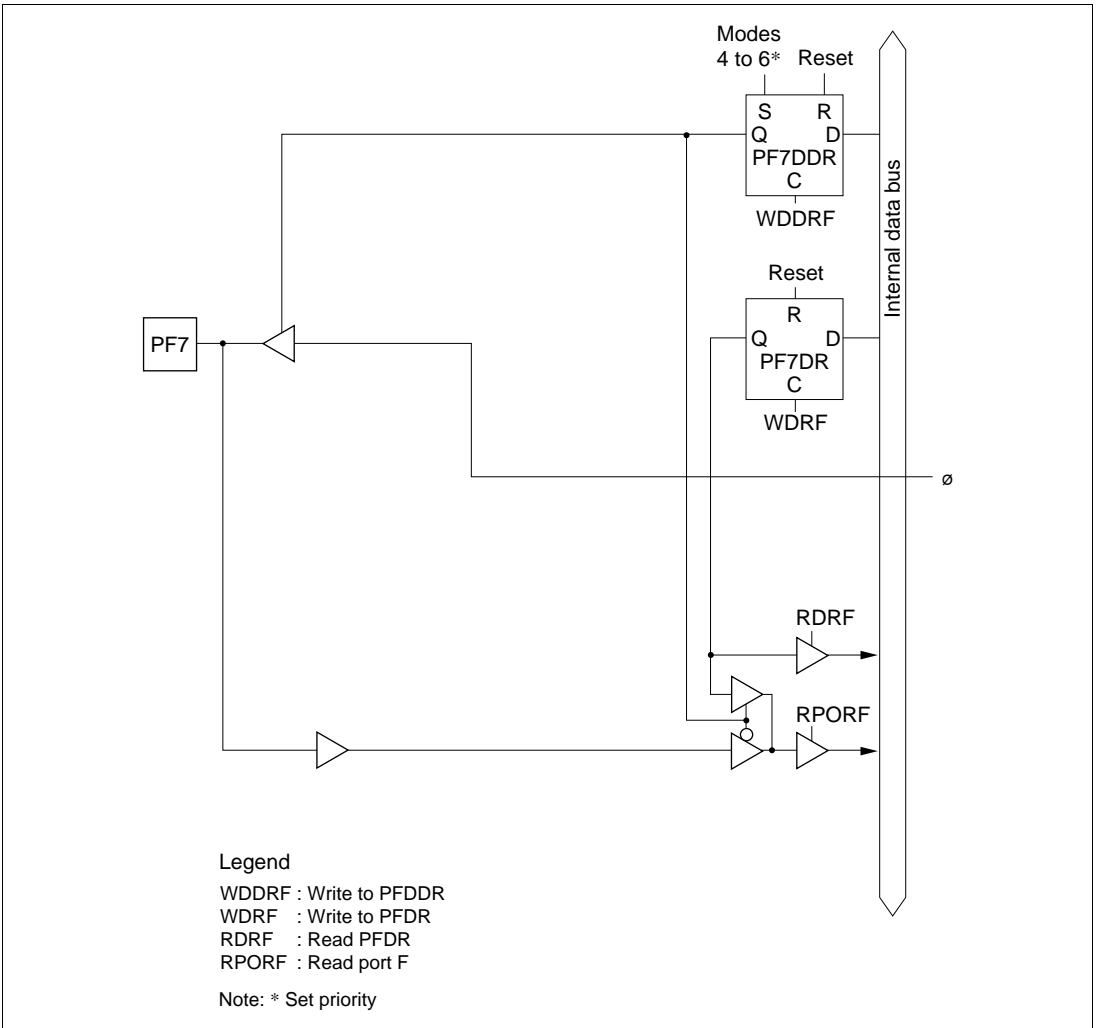




**Figure C.10 (d) Port F Block Diagram (Pin PF3)**







**Figure C.10 (f) Port F Block Diagram (Pin PF7)**

## C.11 Port G Block Diagrams

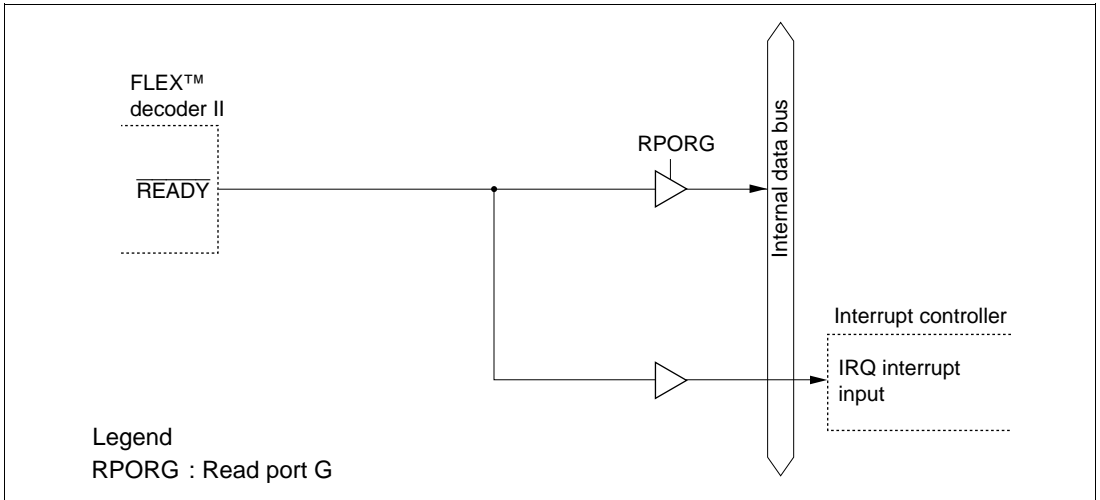
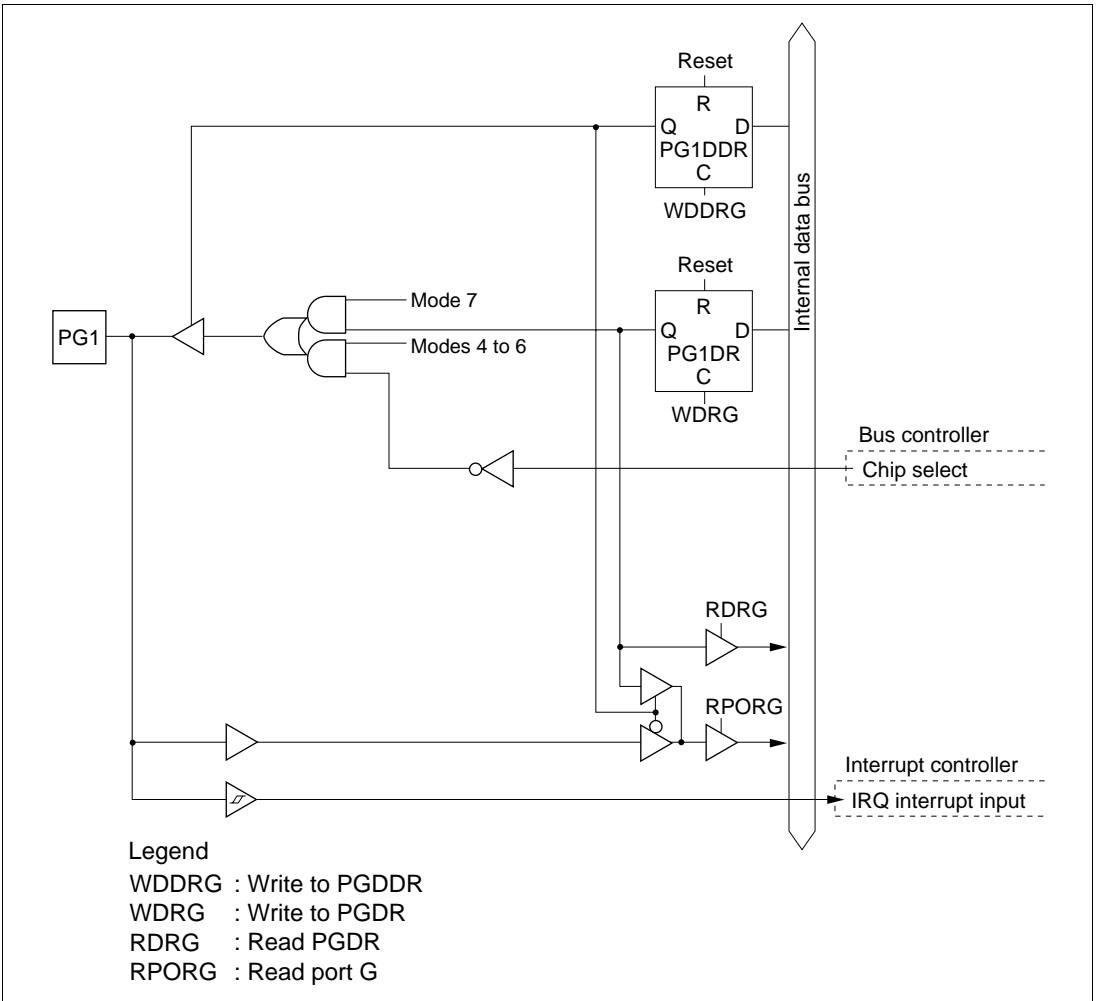
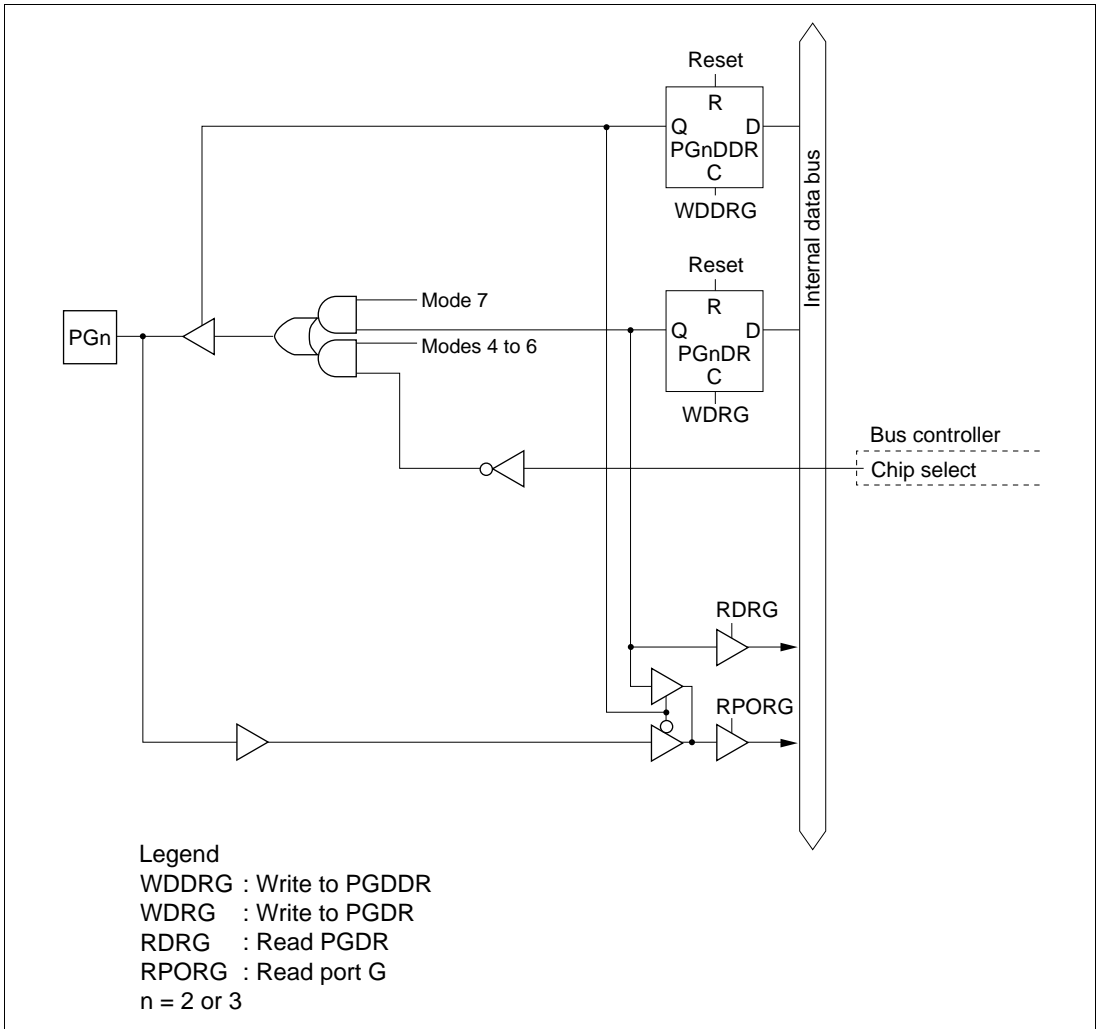


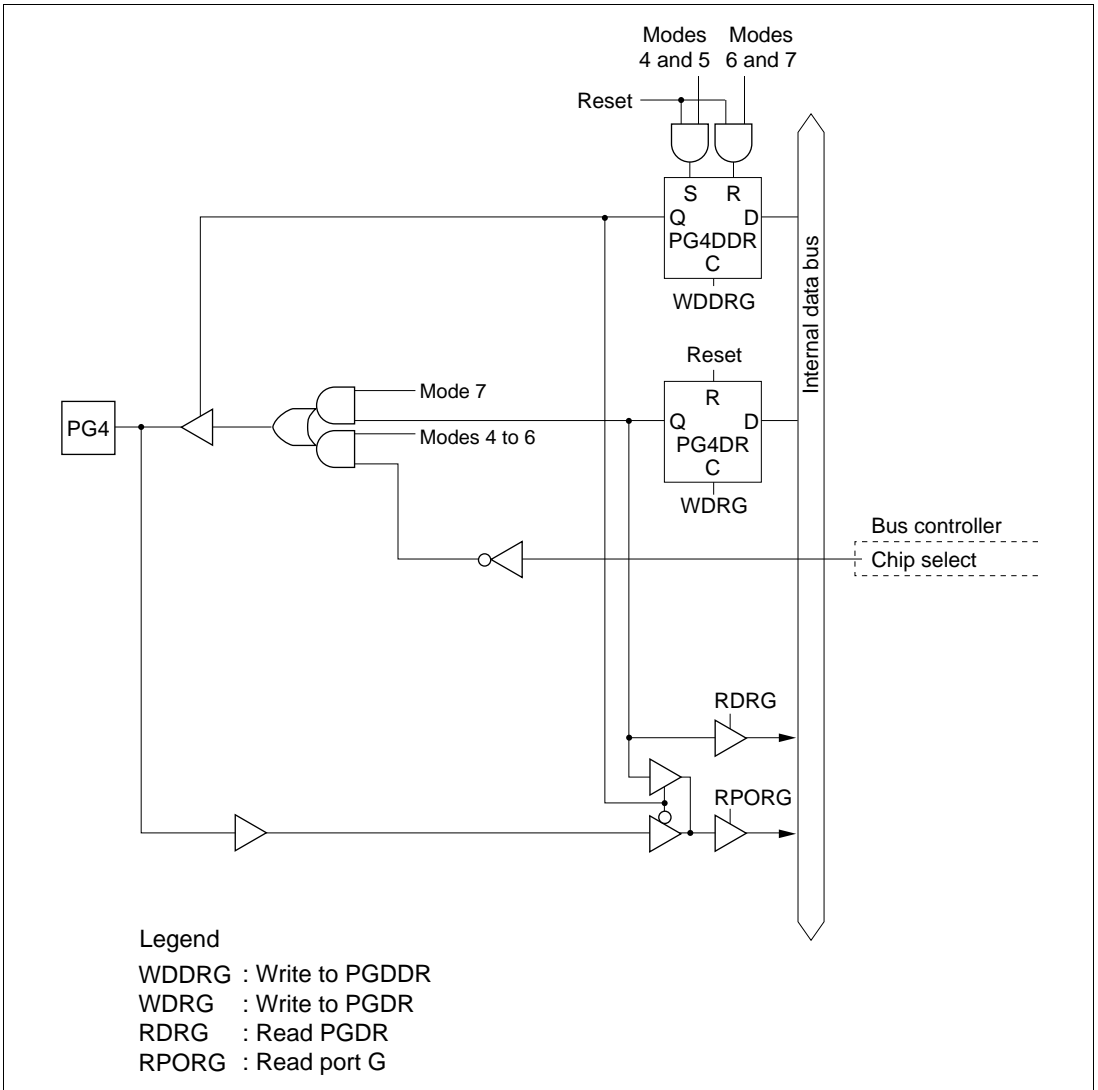
Figure C.11 (a) Port G Block Diagram (Pin PG0)



**Figure C.11 (b) Port G Block Diagram (Pin PG1)**



**Figure C.11 (c) Port G Block Diagram (Pins PG2 and PG3)**



**Figure C.11 (d) Port G Block Diagram (Pin PG4)**

# Appendix D Pin States

## D.1 Port States in Each Processing State

**Table D.1 I/O Port States in Each Processing State**

Port Name Pin Name	MCU Operating Mode	Power-On Reset	Hardware Standby Mode	Software Standby Mode, Watch Mode	Bus-Released State	Program Execution State, Sleep Mode, Subsleep Mode
P16, P14	4 to 7	T	T	keep	keep	I/O port
P13/TIOCD0/TCLKB/A23 P12/TIOCC0/TCLKA/A22 P11/TIOCB0/A21	7	T	T	keep	keep	I/O port
Address output selected by AEn bit	4 to 6	T	T	[OPE= 0] T [OPE= 1] keep	T	Address output
Port selected	4 to 6	T	T	keep	keep	I/O port
P10/TIOCA0/A20	7	T	T	keep	keep	I/O port
Address output selected by AEn bit	4, 5 6	L T	T	[OPE= 0] T [OPE= 1] keep	T	Address output
Port selected	4 to 6	T*	T	keep	keep	I/O port
P36 (dedicated internal I/O port for FLEX™ decoder II)	4 to 7	H	H	keep	keep	I/O port
P35 to P30	4 to 7	T	T	keep	keep	I/O port
Port 4	4 to 7	T	T	T	T	Input port
P77, P75, P74 (dedicated internal I/O port for FLEX™ decoder II)	4 to 7	L	L	keep	keep	I/O port
P76 (dedicated internal input port for FLEX™ decoder II)	4 to 7	MISO	MISO	MISO	MISO	Input port
Port A	7	T	T	keep	keep	I/O port
Address output selected by AEn bit	4, 5 6	L T	T	[OPE= 0] T [OPE= 1] keep	T	Address output
Port selected	4 to 6	T*	T	keep	keep	I/O port
Port B	7	T	T	keep	keep	I/O port
Address output selected by AEn bit	4, 5 6	L T	T	[OPE= 0] T [OPE= 1] keep	T	Address output
Port selected	4 to 6	T*	T	keep	keep	I/O port

Port Name Pin Name	MCU Operating Mode	Power-On Reset	Hardware Standby Mode	Software Standby Mode, Watch Mode	Bus-Released State	Program Execution State, Sleep Mode, Subsleep Mode	
Port C	4, 5	L	T	[OPE= 0] T [OPE= 1] keep	T	Address output	
	6	T	T	[DDR-OPE= 0] T [DDR-OPE= 1] keep	T	[DDR = 0] Input port [DDR = 1] Address output	
	7	T	T	keep	keep	I/O port	
Port D	4 to 6	T	T	T	T	Data bus	
	7	T	T	keep	keep	I/O port	
Port E	8-bit bus	4 to 6	T	T	keep	keep	I/O port
	16-bit bus	4 to 6	T	T	T	T	Data bus
		7	T	T	keep	keep	I/O port
PF7/ $\emptyset$	4 to 6	Clock output T		[DDR= 0] Input port [DDR= 1] H	[DDR= 0] Input port [DDR= 1] Clock output	[DDR= 0] Input port [DDR= 1] Clock output	
	7	T	T	[DDR= 0] Input port [DDR= 1] H	[DDR= 0] Input port [DDR= 1] Clock output	[DDR= 0] Input port [DDR= 1] Clock output	
PF6/ $\overline{AS}$ , PF5/ $\overline{RD}$ , PF4/ $\overline{HWR}$	4 to 6	H	T	[OPE= 0] T [OPE= 1] H	T	$\overline{AS}$ , $\overline{RD}$ , $\overline{HWR}$	
	7	T	T	keep	keep	I/O port	
PF3/ $\overline{LWR}$ / $\overline{ADTRG}$ / IRQ3	7	T	T	keep	keep	I/O port	
	8-bit bus	4 to 6	(Mode 4) H	T	keep	keep	I/O port
	16-bit bus	4 to 6	(Modes 5 and 6) T	T	[OPE= 0] T [OPE= 1] H	T	$\overline{LWR}$
PF2/ $\overline{WAIT}$	4 to 6	T	T	[WAITE= 0] keep [WAITE= 1] T	[WAITE= 0] keep [WAITE= 1] T	[WAITE= 0] I/O port [WAITE= 1] $\overline{WAIT}$	
	7	T	T	keep	keep	I/O port	
PF1/ $\overline{BACK}$ / $\overline{BUZZ}$	4 to 6	T	T	[BRLE= 0] keep [BRLE= 1] H	L	[BRLE= 0] I/O port [BRLE= 1] $\overline{BACK}$	
	7	T	T	keep	keep	I/O port	

Port Name Pin Name	MCU Operating Mode	Power-On Reset	Hardware Standby Mode	Software Standby Mode, Watch Mode	Bus-Released State	Program Execution State, Sleep Mode, Subsleep Mode
PF0/BREQ/IRQ2	4 to 6	T	T	[BRLE= 0] keep [BRLE= 1] T	T	[BRLE= 0] I/O port [BRLE= 1] BREQ
	7	T	T	keep	keep	I/O port
PG4/CS0	4, 5	H	T	[DDR·OPE= 0] T	T	[DDR = 0] I/O port
	6	T		[DDR·OPE= 1] H		[DDR = 1] CS0 (In sleep mode and subsleep mode: H)
	7	T	T	keep	keep	I/O port
PG3/CS1 PG2/CS2 PG1/CS3/IRQ7	4 to 6	T	T	[DDR·OPE= 0] T [DDR·OPE= 1] H	T	[DDR= 0] Input port [DDR= 1] CS1 to CS3
	7	T	T	keep	keep	I/O port
PG0/IRQ6 (dedicated internal input port for FLEX™ decoder II)	4 to 7	READY	READY	READY	READY	Input port

Legend:

H: High level

L: Low level

T: High impedance

keep: Input port becomes high-impedance, output port retains state

DDR: Data direction register

OPE: Output port enable

WAITE: Wait input enable

BRLE: Bus release enable

Note: \* L in modes 4 and 5 (address output)



# Appendix E Timing of Transition to and Recovery from Hardware Standby Mode

## Timing of Transition to Hardware Standby Mode

- (1) To retain RAM contents with the RAME bit set to 1 in SYSCR, drive the  $\overline{\text{RES}}$  signal low at least 10 states before the  $\overline{\text{STBY}}$  signal goes low, as shown below.  $\overline{\text{RES}}$  must remain low until  $\overline{\text{STBY}}$  signal goes low (delay from  $\overline{\text{STBY}}$  low to  $\overline{\text{RES}}$  high: 0 ns or more).

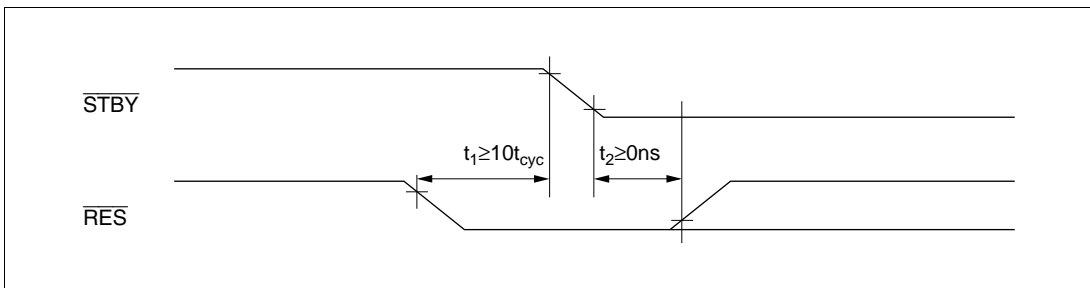


Figure E.1 Timing of Transition to Hardware Standby Mode

- (2) To retain RAM contents with the RAME bit cleared to 0 in SYSCR, or when RAM contents do not need to be retained,  $\overline{\text{RES}}$  does not have to be driven low as in (1).

## Timing of Recovery from Hardware Standby Mode

Drive the  $\overline{\text{RES}}$  signal low approximately 100 ns or more before  $\overline{\text{STBY}}$  goes high to execute a power-on reset.

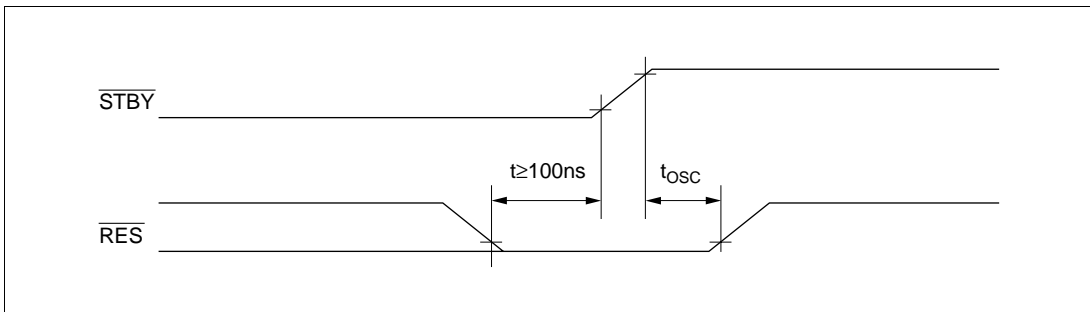


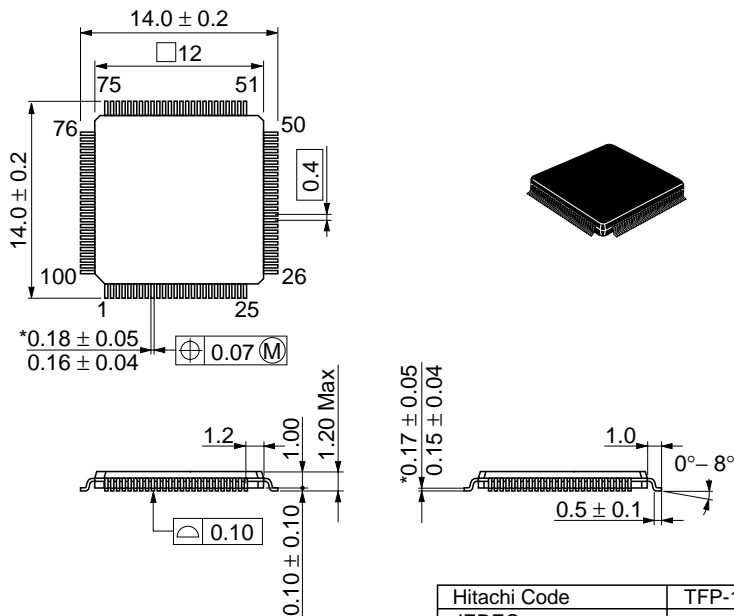
Figure E.2 Timing of Recovery from Hardware Standby Mode

# Appendix F Product Code Lineup

**Table F.1 H8S/2276 Series Product Code Lineup**

<b>Product Type</b>		<b>Product Code</b>	<b>Package</b>
H8S/2277	Non-roaming	HD64F2277	TFP-100B, TFP-100G
H8S/2277R	Roaming	HD64F2277R	





\*Dimension including the plating thickness  
Base material dimension

Hitachi Code	TFP-100G
JEDEC	-
JEITA	Conforms
Mass (reference value)	0.4 g

Figure G.2 TFP-100G Package Dimensions

---

## **H8S/2276 Series, H8S/2277 F-ZTAT™ Hardware Manual**

Publication Date: 1st Edition, December 2001

Published by: Business Planning Division  
Semiconductor & Integrated Circuits  
Hitachi, Ltd.

Edited by: Technical Documentation Group  
Hitachi Kodaira Semiconductor Co., Ltd.

Copyright © Hitachi, Ltd., 2001. All rights reserved. Printed in Japan.