

SFP Copper Transceiver 10/100/1000Base-T SGMII

SFP-1GBT-05



FEATURES / BENEFITS

- Designed with Broadcom's BCM54616S chipset (login at <https://support.broadcom.com/Core/Login.aspx> for IC support)
- Complies with IEEE 802.3, 802.3u, and 802.3ab specifications
- Conforms to Multi-Source Agreement (MSA) specifications for SFP transceivers
- Supports IEEE 802.3u and IEEE 802.3ab auto-negotiation features to allow networking equipment to automatically determine and adjust the required settings
- Operates in extended temperature range of -40° to +85° C
- Automatically compensates for baseline wander by removing the DC offset from the input signal
- Assembled with low EMI emissions IC and fully metallic housings
- Automatic dependent interface (DI) crossover, eliminating the need for crossover cables or cross-wire (MDIX) ports
- Bail latch provides ease of extraction
- Compact RJ45 connector assembly
- Data is scrambled to reduce radiated emission
- Power consumption is 610mW typical for 1000Base-T
- Power consumption is 320mW typical for 10/100Base-T
- The 10/100/1000Base-T physical layer IC (PHY) can be accessed via i2c interface
- Fully RoHS compliant
- The BCM54616S physical layer IC (PHY) can be accessed via I²C interface:
 - PHY address = "ACh"
 - EEPROM memory address = "A0h"

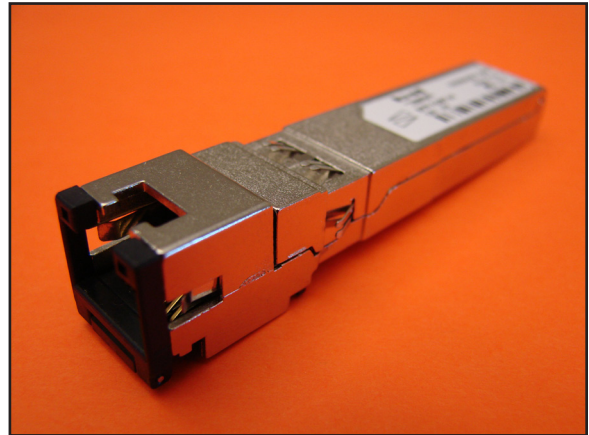

APPLICATIONS

- 10/100/1000 Mbps data rate in excess of 100 meters of Category 5/5e cable
- Industrial temperature environments -40° to +85° C
- Networking equipment
- Switch-to-switch interface
- Routers

The Bel SFP-1GBT-05 transceiver is an internally configured 10/100/1000Base-T SFP that requires the host system to provide SGMII interface. The PHY interfaces directly with SerDes interface. The host interface transmits and receives serial data differentially at 1.25 Gbps. The copper interface is full featured as advertised full/half duplex and 1000Base-T wire speed.

- SFP Transceiver identification is specified as "08h" for byte 6 in the EEPROM.

REGULATORY AND STANDARDS COMPLIANCE

- Compliant with IEEE 802.3:2000
- FCC Part 15, Class A
- EN55022 Class A (CISPR 22 Class A)
- CE
- E55024 Immunity standard and NEBS 3 ESD



SFP Copper Transceiver 10/100/1000Base-T SGMII
SFP-1GBT-05



RELIABILITY TESTING

Vibration Test: Reference MIL-STD-202, Method 204. Condition D.

Mechanical Shock: Reference IEC 68-2-27, Test Ea. Alternative MIL-STD-202, Method 213B, Condition A.

Temperature cycling and temperature-humidity-bias.

SFP-1BGT-05 MODULE SPECIFICATIONS

Parameter	Symbol	Min	Typ	Max	Units	Notes
Supply Voltage	V_{DD3}	3.12	3.3	3.46	V	
Supply Current	I_S		185		mA	1000Base-T
Supply Current	I_S		98		mA	10/100Base-T

SFP Host Serial Interface (TX/RX)	Symbol	Min	Typ	Max	Units	Notes
Line Frequency	F_{LINE}		125		MHz	
TX Output Impedance	Z_{TX_OUT}		100		Ω	Differential
RX Output Impedance	Z_{RX_IN}		100		Ω	Differential
Clock Frequency			25		MHz	
Rise/Fall Time	T_R/T_F		4		ns	20% - 80%
RMS Phase Jitter	F_J			1.5	ps-rms	$F_J = 12$ kHz to 20 MHz offset frequency.

Environmental Specifications	Symbol	Min	Typ	Max	Units	Notes
Operating Temp	T_{OP}	-40		+85	$^{\circ}C$	Case temperature
Storage Temp	T_{STG}	-40		+85	$^{\circ}C$	Ambient temperature

SFP Copper Transceiver 10/100/1000Base-T SGMII
SFP-1GBT-05



SFP HOST CONNECT ELECTRICAL INTERFACE AND PINS DESCRIPTIONS

Pin	Name	Description
1	VeeT	Transmitter ground (common with receiver ground).
2	TX Fault	Transmitter fault is internally tied to transmit ground and is not supported.
3	TX Disable	Transmit disable. This pin is tied to PHY low power mode.
4	MOD-DEF2	Signal SDA (data) of the two-wire serial ID interface.
5	MOD-DEF1	Signal SCL (clock) of the two-wire serial ID interface.
6	MOD-DEF0	This pin is internally tied to transmit ground.
7	Rate Select	Not implemented. This pin is floating internally.
8	LOS	Loss of signal indication.
9	VeeR	Receiver ground (common with transmitter ground).
10	VeeR	Receiver ground (common with transmitter ground).
11	VeeR	Receiver ground (common with transmitter ground).
12	RD-	Differential receiver outputs. User to terminate to 100 Ω differential at host. AC coupled.
13	RD+	Differential receiver outputs. User to terminate to 100 Ω differential at host. AC coupled.
14	VeeR	Receiver ground (common with transmitter ground).
15	VccR	3.3V power
16	VccT	3.3V power
17	VeeT	Transmitter ground (common with receiver ground).
18	TD+	Differential transmitter outputs. User to terminate to 100 Ω differential at host. AC coupled.
19	TD-	User to terminate to 100 Ω differential at host. AC coupled.
20	VeeT	Transmitter ground (common with receiver ground).



SFP Copper Transceiver 10/100/1000Base-T SGMII SFP-1GBT-05

SGMII INSTALLATION GUIDE

Part Number	Link Indicator on Rx_LOS Pin	Auto-Negotiation enabled by default	Interface
SFP-1GBT-05	Yes	Yes	SGMII (10/100/1000Base-T)

- **Rx_LOS** is always ENABLE.
 - High —> Not linked.
 - Low —> Linked to link-partner.
- Customer's **MAC** should be setup for **SGMII interface with Auto-Negotiation** and the preferred mode of operation. There is no need for accessing the PHY registers of the Broadcom PHY of the SFP-1GBT-05 Transceiver.
- Bel's Copper SFP-1GBT-05 Transceiver will automatically detect the advertised speed and mode of operation via the host of the link-partner.
 - Default is 1000BASE-T (Full-Duplex or Half-Duplex).
 - Bel's Copper SFP-1GBT-05 Transceiver will automatically detect advertised 100Base-T speed and mode of operations (Full-Duplex or Half-Duplex) from the **MAC** and link to its link-partner.
 - Bel's Copper SFP-1GBT-05 Transceiver will automatically detect advertised 10Base-T speed and mode of operation (Full-Duplex or Half-Duplex) from the **MAC** and link to its link-partner.

Depending on the condition of the MAC configuration, the SFP-1GBT-05 Transceiver can also be forced to operate at the preferred speed and mode of operation by accessing the **Broadcom PHY** registers via "**0xAC**" address:

- 1000Base-T Full-Duplex and/or Half-Duplex — by default.
- Forcing the SFP-1GBT-05 to operate at **100Base-T** Full-Duplex and/or Half-Duplex:
 1. Force Full-Duplex mode:
Write PHY register 00h to 0x2100h. (Force copper operate at 100Base-T Full-Duplex mode)
 2. Force Half-Duplex mode:
Write PHY register 00h to 0x2000h. (Force copper operate at 100Base-T Half-Duplex mode)
 3. Auto-Negotiation mode:
Write PHY register 09h to 0x0000. (Disable 1000Base-T ability)
Write PHY register 00h to 0x1340. (Restart Auto-Negotiation)

SFP Copper Transceiver 10/100/1000Base-T SGMII SFP-1GBT-05



- Forcing the SFP-1GBT-05 to operate at 10Base-T Full-Duplex and/or half-duplex
1. Force full-duplex mode:
Write PHY register 00h to 0x0100h. (Force copper operate at 10Base-T Full-Duplex mode)
 2. Force half-duplex mode:
Write PHY register 00h to 0x0000h. (Force copper operate at 10Base-T Half-Duplex mode)
 3. Auto-Negotiation mode:
Write PHY register 09h to 0x0000. (Disable 1000Base-T ability)
Write PHY register 04h to 0x0061. (Disable 100Base-T ability)
Write PHY register 00h to 0x1340. (Restart Auto-Negotiation)

SGMII-Copper to GBIC:

- If the GBIC Interface is required, Bel would recommend the SFP-1GBT-06 Transceiver for installation.
- However, SFP-1GBT-05 Transceiver can also be configured to operate in GBIC (1000Base-X to 1000Base-T) interface by accessing the Broadcom PHY registers via "0xAC":
 1. Write register 18h, shadow 07h bit [7] = 0 (Disable RGMII mode)
 2. Write register 1Ch, shadow 1Fh bit [0] = 1 (Enable fiber register bank)
 3. Write register 00h, bit [11] = 1 (Power-down SerDes interface)
 4. Write register 1Ch, shadow 1Fh bit [2:1] = 11 (Configure the BCM54616S in GBIC mode)
 5. Write register 00h, bit [11] = 0 (Power-up SerDes interface)
 6. Write register 1Ch, shadow 1Fh bit [0] = 0 (Enable copper register bank)
 7. Write register 00h, bit [11] = 0 (power up copper interface)

MAC Auto-Negotiation vs. MAC without Auto-Negotiation:

In case of MAC does not have Auto-Negotiation capability, the Auto-Negotiation of the SFP-1GBT-05 can also be disabled by clear the Broadcom PHY register bit12 to "0", then attempt to install the Bel's SFP Transceiver.



MECHANICAL

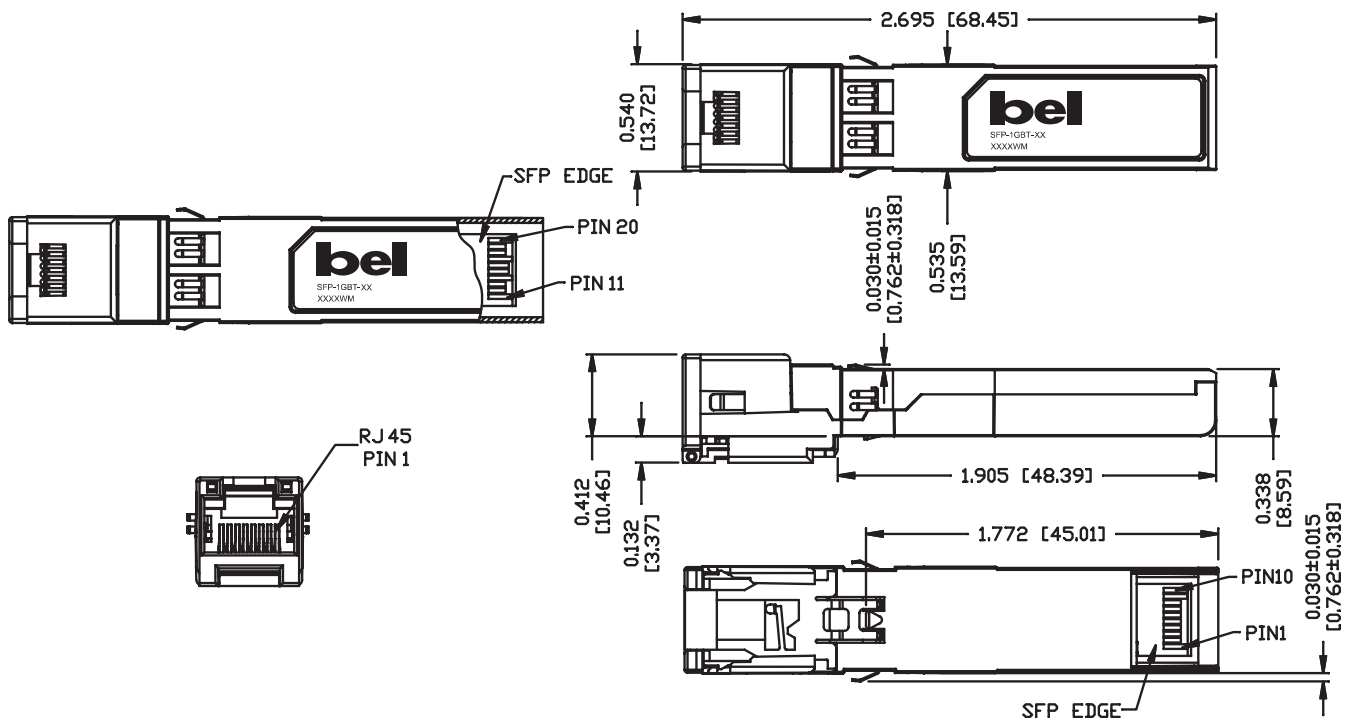

©2012 Bel Fuse Inc. Specifications subject to change without notice. 02.06.12

CORPORATE

Bel Fuse Inc.
206 Van Vorst Street
Jersey City, NJ 07302
Tel 201-432-0463
Fax 201-432-9542
www.belfuse.com

ASIA

Bel Fuse Ltd.
8F / 8 Luk Hop Street
San Po Kong
Kowloon, Hong Kong
Tel 852-2328-5515
Fax 852-2352-3706
www.belfuse.com

EUROPE

Bel Stewart Connector
45/46 Riverside
Medway City Estate
Rochester, Kent ME2 4DP U.K.
Tel 44-1634-722890
Fax 44-1634-716677
www.belfuse.com