

ULTRA FAST-RECOVERY RECTIFIER DIODES FEATURING LOW REVERSE LEAKAGE

Glass-passivated, high-efficiency epitaxial rectifier diodes in plastic envelopes, featuring low reverse leakage current, low forward voltage drop, ultra fast reverse recovery times, very low stored charge and soft recovery characteristics. They are intended for use in switched-mode power supplies and high-frequency circuits in general, where both low conduction and low switching losses are essential. The series consists of normal polarity (cathode to mounting base) types.

QUICK REFERENCE DATA

			BYP21-50	100	150	200	
Repetitive peak reverse voltage	V_{RRM}	max.	50	100	150	200	V
Average forward current	$I_F(AV)$	max.	8				A
Forward voltage	V_F	<	0.895				V
Reverse recovery time	t_{rr}	<	25				ns
Reverse leakage current	I_R	<	5				μA

MECHANICAL DATA

Dimensions in mm

Fig.1 TO-220AC

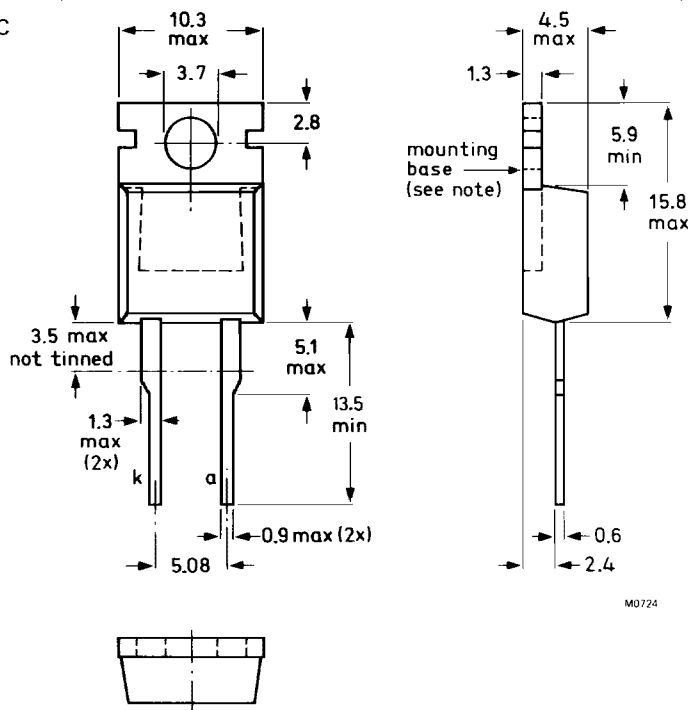

M0724

Net mass: 2 g

Note: The exposed metal mounting base is directly connected to the cathode.

Accessories supplied on request: see data sheets Mounting instructions and accessories for TO-220 envelopes.

RATINGS

Limiting values in accordance with the Absolute Maximum System (IEC 134).

Voltages

			BYP21-50	100	150	200	
Repetitive peak reverse voltage	V_{RRM}	max.	50	100	150	200	V
Crest working reverse voltage	V_{RWM}	max.	50	100	150	200	V
Continuous reverse voltage	V_R	max.	50	100	150	200	V

Currents

Average forward current; switching losses negligible up to 500 kHz square wave; $\delta = 0.5$; up to $T_{mb} = 150^\circ\text{C}$

up to $T_{mb} = 150^\circ\text{C}$	$I_{F(AV)}$	max.		8			A
sinusoidal; up to $T_{mb} = 150^\circ\text{C}$	$I_{F(AV)}$	max.		9.4			A

R.M.S. forward current	$I_{F(RMS)}$	max.		11.5			A
------------------------	--------------	------	--	------	--	--	---

Repetitive peak forward current $t_p = 20 \mu\text{s}$; $\delta = 0.02$	I_{FRM}	max.		175			A
---	-----------	------	--	-----	--	--	---

Non-repetitive peak forward current half sine-wave; $T_j = 175^\circ\text{C}$ prior to surge; with reapplied V_{RWMmax}

$t = 10 \text{ ms}$	I_{FSM}	max.		80			A
$t = 8.3 \text{ ms}$	I_{FSM}	max.		100			A

I^2t for fusing ($t = 10 \text{ ms}$)	I^2t	max.		32			A^2s
---	--------	------	--	----	--	--	----------------------

Temperatures

Storage temperature	T_{stg}			-65 to +175			$^\circ\text{C}$
Junction temperature	T_j	max.		175			$^\circ\text{C}$

THERMAL RESISTANCE

From junction to mounting base

$$R_{th\ j-mb} = 2.7 \text{ K/W}$$

Influence of mounting method

1. Heatsink mounted with clip (see mounting instructions)

Thermal resistance from mounting base to heatsink

a. with heatsink compound

$$R_{th\ mb-h} = 0.3 \text{ K/W}$$

b. with heatsink compound and 0.06 mm maximum mica insulator

$$R_{th\ mb-h} = 1.4 \text{ K/W}$$

c. with heatsink compound and 0.1 mm maximum mica washer (56369)

$$R_{th\ mb-h} = 2.2 \text{ K/W}$$

d. with heatsink compound and 0.25 mm maximum alumina insulator (56367)

$$R_{th\ mb-h} = 0.8 \text{ K/W}$$

e. without heatsink compound

$$R_{th\ mb-h} = 1.4 \text{ K/W}$$

2. Free air operation

The quoted values of $R_{th\ j-a}$ should be used only when no leads of other dissipating components run to the same tie point.Thermal resistance from junction to ambient in free air:
mounted on a printed circuit board at

a = any lead length

$$R_{th\ j-a} = 60 \text{ K/W}$$

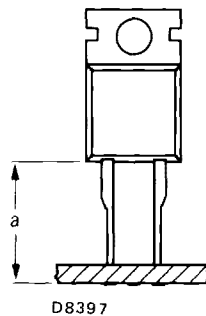

Fig.2

CHARACTERISTICS

Forward voltage

$$I_F = 8 \text{ A}; T_j = 100 \text{ }^\circ\text{C}$$

$$V_F < 0.895 \text{ V}^*$$

$$I_F = 8 \text{ A}; T_j = 25 \text{ }^\circ\text{C}$$

$$V_F < 1.045 \text{ V}^*$$

$$I_F = 20 \text{ A}; T_j = 25 \text{ }^\circ\text{C}$$

$$V_F < 1.15 \text{ V}^*$$

Reverse current

$$V_R = V_{RWMmax}; T_j = 175 \text{ }^\circ\text{C}$$

$$I_R < 500 \text{ } \mu\text{A}$$

$$T_j = 125 \text{ }^\circ\text{C}$$

$$I_R < 250 \text{ } \mu\text{A}$$

$$T_j = 100 \text{ }^\circ\text{C}$$

$$I_R < 50 \text{ } \mu\text{A}$$

$$T_j = 25 \text{ }^\circ\text{C}$$

$$I_R < 5 \text{ } \mu\text{A}$$

Reverse recovery when switched from

$$I_F = 1 \text{ A to } V_R \geq 30 \text{ V with } -dI_F/dt = 100 \text{ A}/\mu\text{s};$$

$$T_j = 25 \text{ }^\circ\text{C}; \text{ recovery time}$$

$$t_{rr} < 25 \text{ ns}$$

Step reverse recovery when switched from

$$I_F = 0.5 \text{ A to } I_R = 1 \text{ A, measured at}$$

$$I_{RR} = 0.25 \text{ A; recovery time}$$

$$t_{rr} < 25 \text{ ns}$$

$$I_F = 2 \text{ A to } V_R \geq 30 \text{ V with } -dI_F/dt = 20 \text{ A}/\mu\text{s};$$

$$T_j = 25 \text{ }^\circ\text{C}; \text{ recovered charge}$$

$$Q_s < 15 \text{ nC}$$

$$I_F = 10 \text{ A to } V_R \geq 30 \text{ V with } -dI_F/dt = 50 \text{ A}/\mu\text{s};$$

$$T_j = 100 \text{ }^\circ\text{C}; \text{ peak recovery current}$$

$$I_{RRM} < 2 \text{ A}$$

Forward recovery when switched to $I_F = 1 \text{ A}$

$$\text{with } dI_F/dt = 10 \text{ A}/\mu\text{s}; T_j = 25 \text{ }^\circ\text{C}$$

$$V_{fr} \text{ typ. } 0.9 \text{ V}$$

M80-1319/3

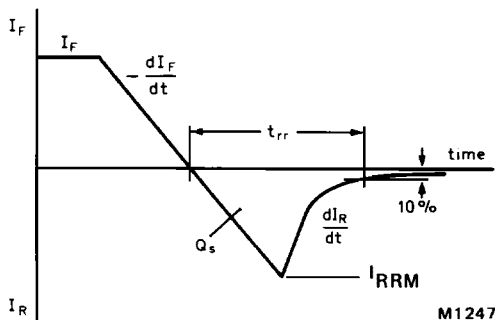

Fig.3 Definition of t_{rr} , Q_s and I_{RRM} .

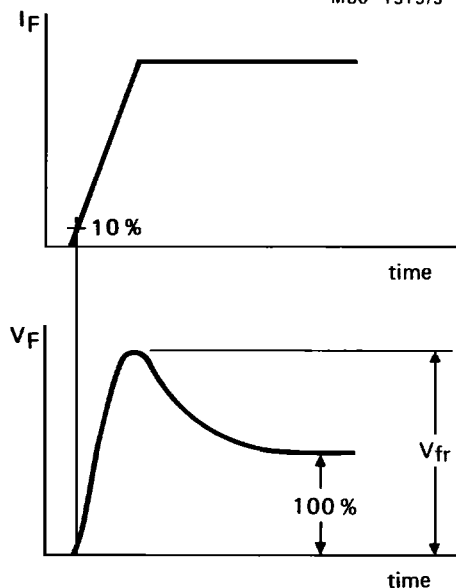

Fig.4 Definition of V_{fr} .

*Measured under pulse conditions to avoid excessive dissipation.

MOUNTING INSTRUCTIONS

1. The device may be soldered directly into the circuit, but the maximum permissible temperature of the soldering iron or bath is 275°C; the heat source must not be in contact with the joint for more than 5 seconds. Soldered joints must be at least 4.7 mm from the seal.
2. The leads should not be bent less than 2.4 mm from the seal, and should be supported during bending. The bend radius must be no less than 1.0 mm.
3. Mounting by means of a spring clip is the best mounting method because it offers:
 - a. a good thermal contact under the crystal area and slightly lower $R_{th\ mb-h}$ values than does screw mounting.
 - b. safe isolation for mains operation.
 However, if a screw is used, it should be M3 cross-recess pan head. Care should be taken to avoid damage to the plastic body.
4. For good thermal contact, heatsink compound should be used between mounting base and heatsink. Values of $R_{th\ mb-h}$ given for mounting with heatsink compound refer to the use of a metallic oxide-loaded compound. Ordinary silicone grease is not recommended.
5. Rivet mounting (only possible for non-insulated mounting).
Devices may be rivetted to flat heatsinks; such a process must **neither** deform the mounting tab, **nor** enlarge the mounting hole.

OPERATING NOTES

Dissipation and heatsink considerations:

- a. The various components of junction temperature rise above ambient are illustrated below:

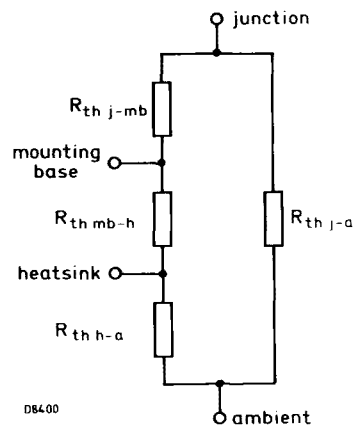

Fig.5

- b. The method of using Figs.6 and 7 is as follows:
Starting with the required current on the $I_F(AV)$ axis, trace upwards to meet the appropriate duty factor or form factor curve. Trace right horizontally and upwards from the appropriate value on the T_{amb} scale. The intersection determines the $R_{th\ mb-a}$. The heatsink thermal resistance value ($R_{th\ h-a}$) can now be calculated from:
$$R_{th\ h-a} = R_{th\ mb-a} - R_{th\ mb-h}$$
- c. Any measurement of heatsink temperature should be made immediately adjacent to the device.

SQUARE-WAVE OPERATION

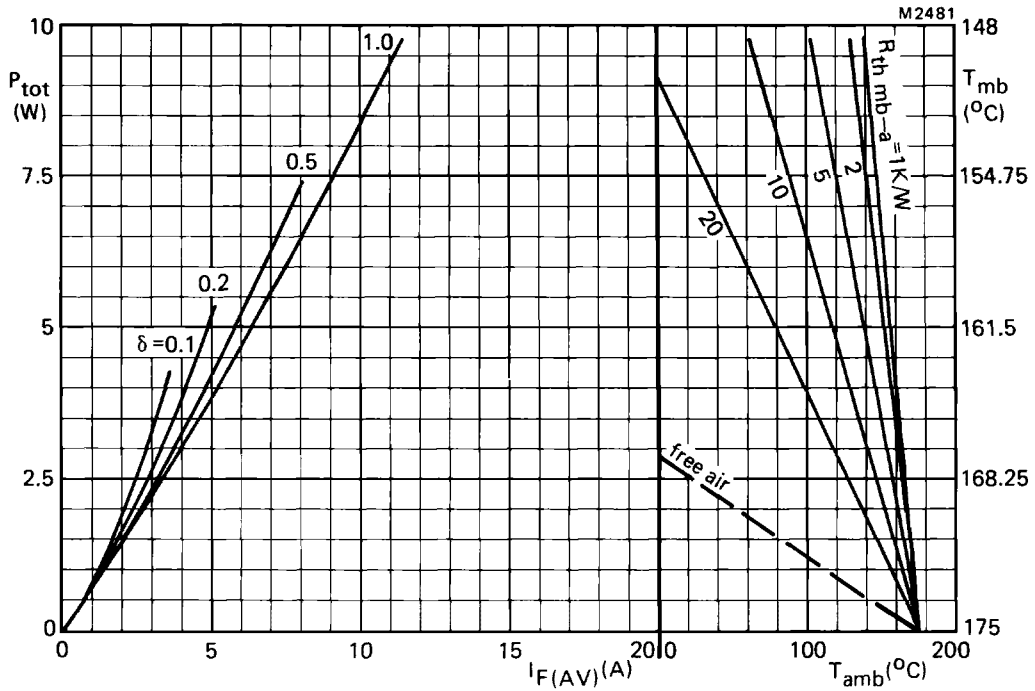
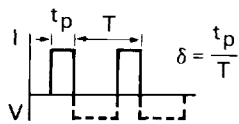

Fig.6 The right-hand part shows the relationship between the power (derived from the left-hand part) and the maximum permissible temperatures. Power includes reverse current losses and switching losses up to $f = 500$ kHz.



$$I_{F(AV)} = I_{F(RMS)} \times \sqrt{\delta}$$

SINUSOIDAL OPERATION

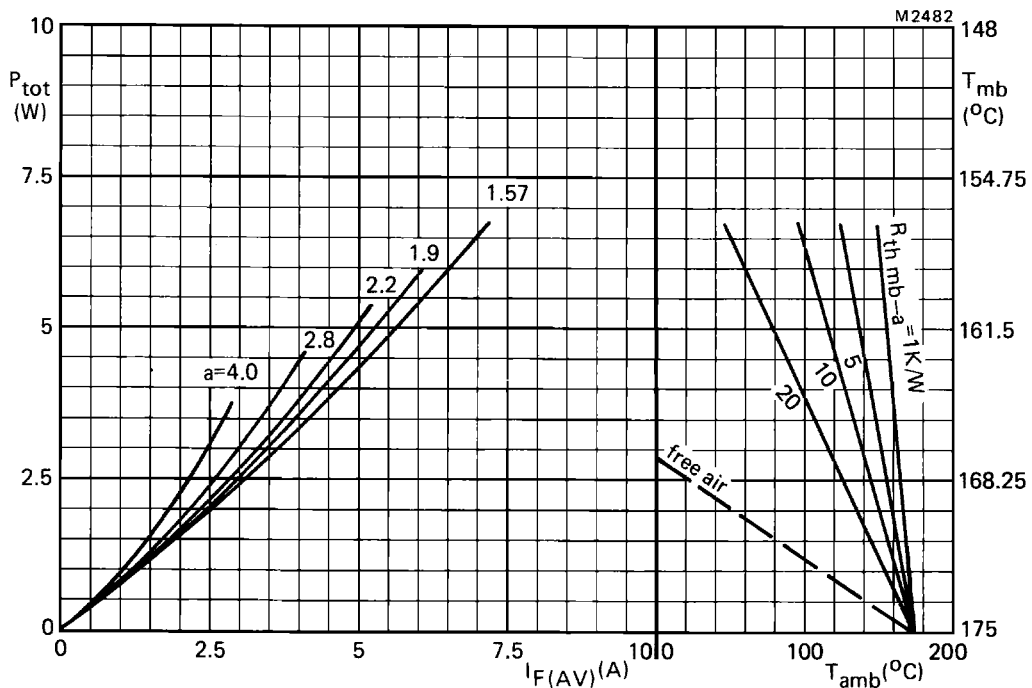

Fig.7 The right-hand part shows the interrelationship between the power (derived from the left-hand part) and the maximum permissible temperatures.

a = form factor = $I_{F(RMS)}/I_{F(AV)}$.

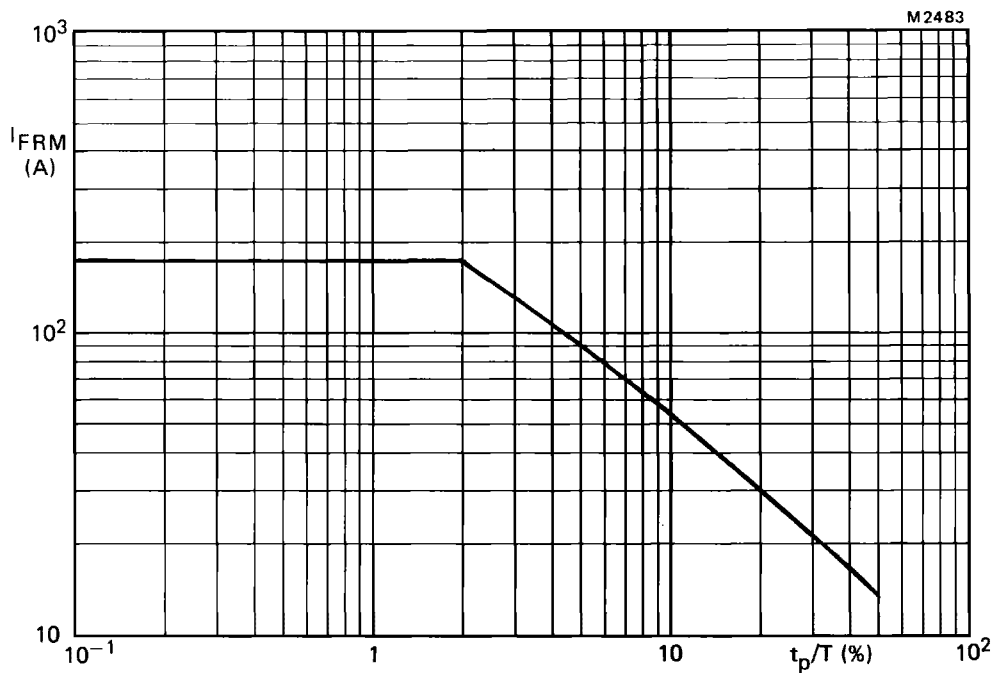
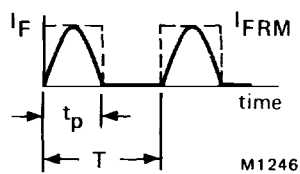
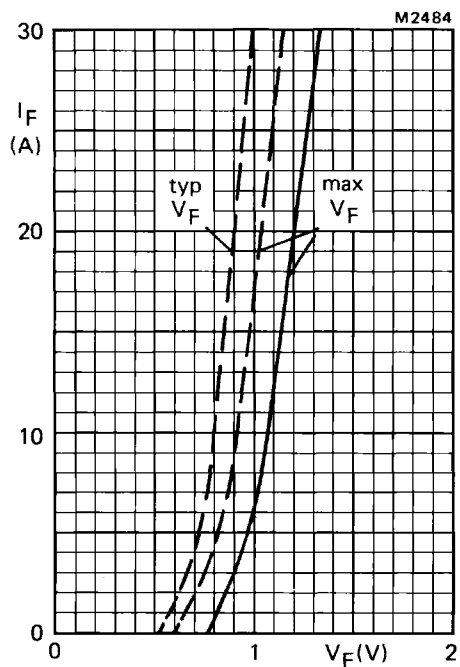

Fig.8 Maximum permissible repetitive peak forward current for square or sinusoidal currents; $1 \mu s < t_p < 1$ ms.



Definition of I_{FRM} and t_p/T .

Fig.9 — $T_j = 25^\circ C$; - - - $T_j = 100^\circ C$.

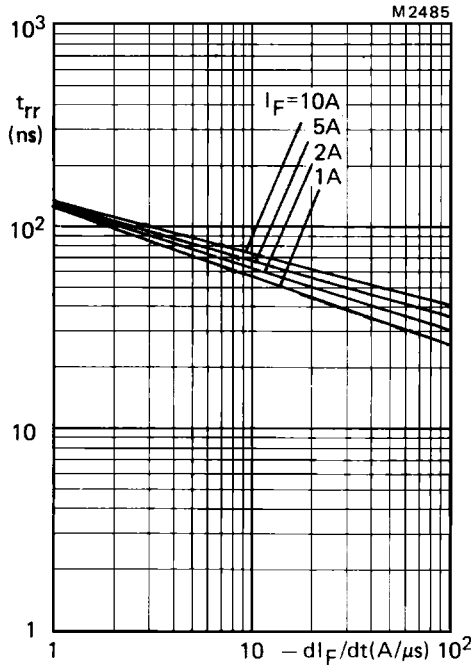

Fig.10 Maximum t_{rr} at $T_j = 25^\circ C$.

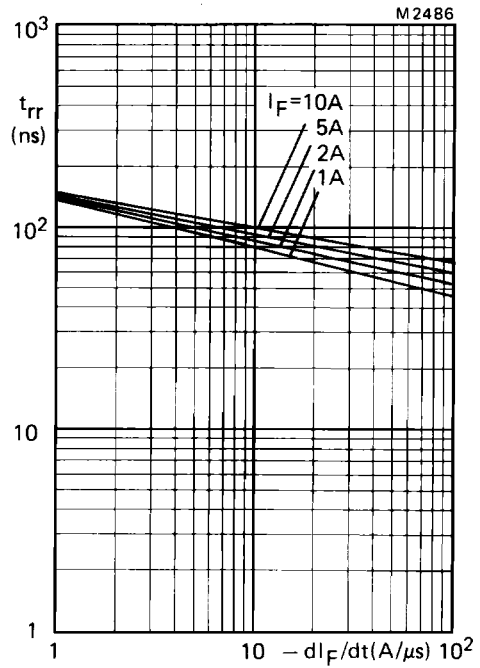

Fig.11 Maximum t_{rr} at $T_j = 100^\circ C$.

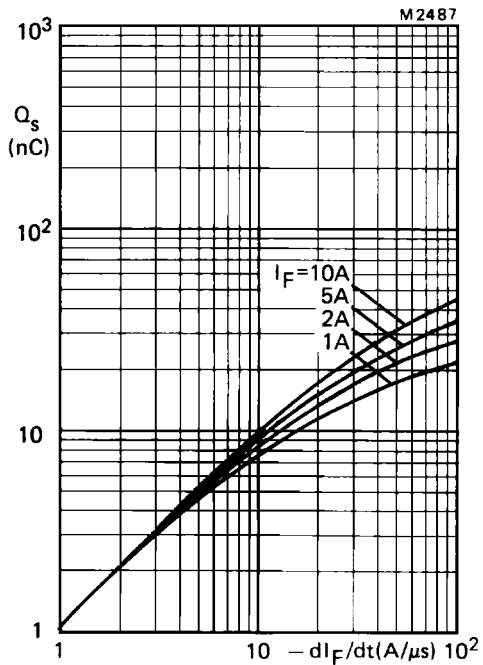

Fig.12 Maximum Q_s at $T_j = 25^\circ C$.

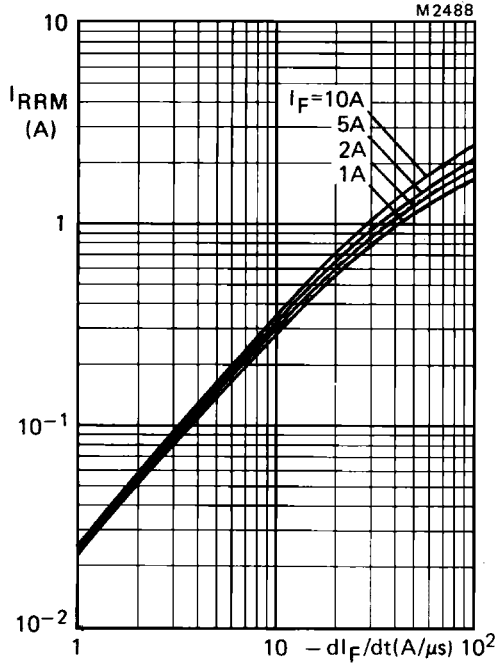

Fig.13 Maximum I_{RRM} at $T_j = 25$ °C.

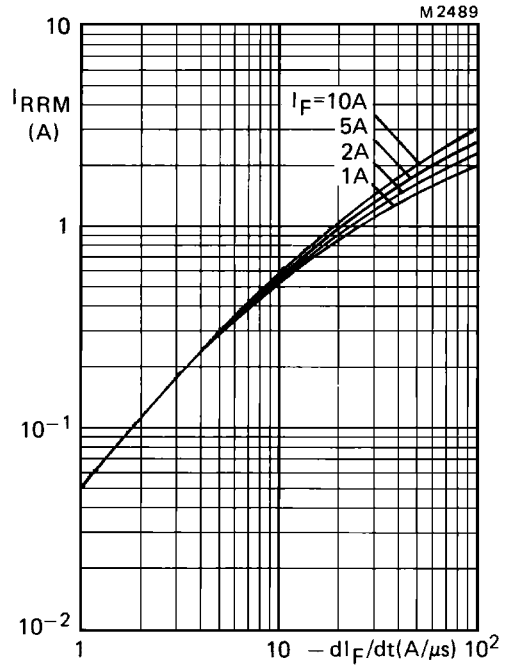

Fig.14 Maximum I_{RRM} at $T_j = 100$ °C.

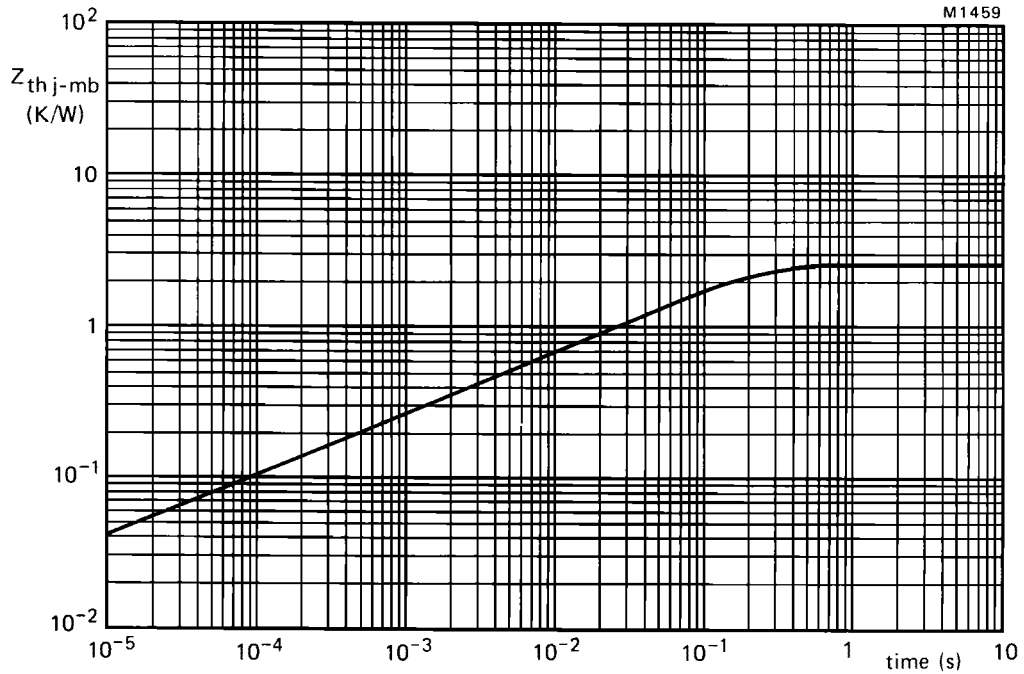

Fig.15 Transient thermal impedance.