

# ZN1066E/J

## SWITCHING REGULATOR CONTROL AND DRIVE UNIT

The ZN1066 is designed to satisfy the requirement for a general purpose control and drive unit in switching power supplies, transformer coupled DC/DC converters, transformerless voltage doublers, polarity converters, motor speed control and other power control applications.

### FEATURES

- Complete PWM Power Control Circuitry
- Single Ended or Push-Pull Totem Pole Type Outputs with  $\pm 120\text{mA}$  Capability
- 0-100% Duty Cycle Control
- Feedback Control Guarantees Non-Overlap of Output Pulses
- No Dead Time Setting Required
- Output Frequency Adjustable up to 500kHz
- Independent Control of Output Voltage and Output Current
- 2.6V Stable Reference  $\pm 50\text{ppm}/\square\text{C}$
- Inhibit and Synchronising Input

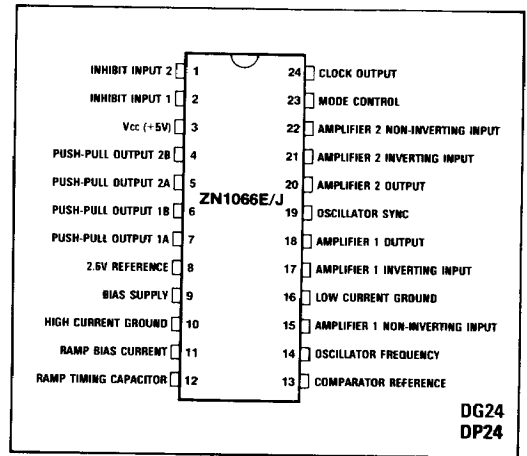

Fig.1 Pin connections - top view

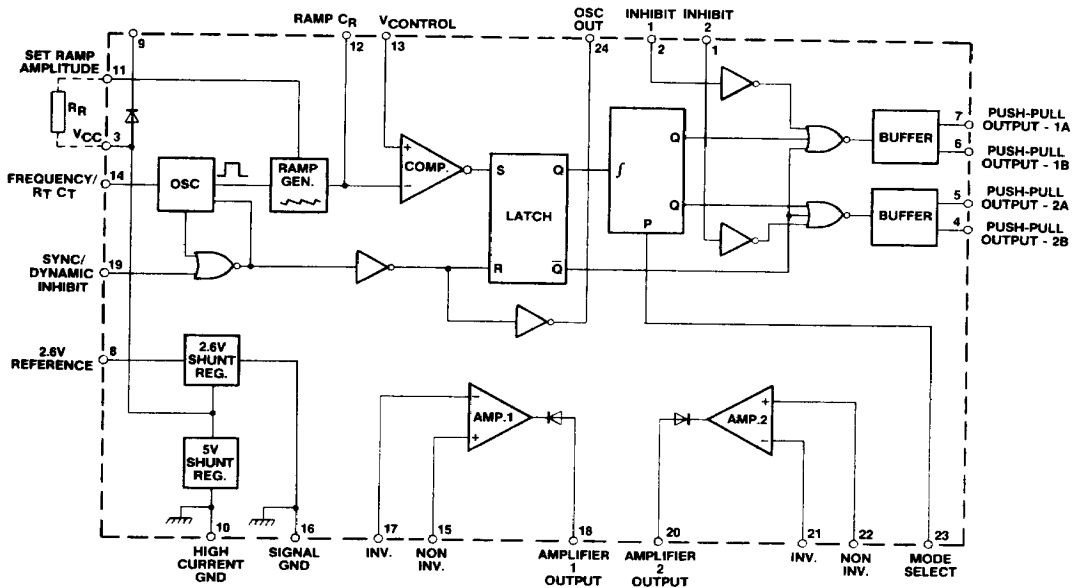

Fig.2 Block diagram of ZN1066E/J

## ELECTRICAL CHARACTERISTICS

Test conditions (unless otherwise stated):

 $T_{amb} = 25^{\circ}\text{C}$ 

Characteristic	Value			Units	Conditions
	Min.	Typ.	Max.		
<b>Shunt regulator section</b>					
Output voltage ( $I_{cc} = 60\text{mA}$ )	4.75	5.0	5.25	V	See Notes 1 and 2
Voltage temperature coefficient ( $I_{cc} = 60\text{mA}$ )	-	100	-	ppm/ $^{\circ}\text{C}$	
Output impedance	-	1.5	3	$\Omega$	Shunt regulator just on
Supply current	-	40	-	mA	
<b>Amplifier section</b>					
Open loop voltage gain	800	1200	-		With 1k pull up
Input bias current	-	1	4	$\mu\text{A}$	
Input offset current	-	0.2	2	$\mu\text{A}$	
Input offset voltage	-	2	5	mV	
Offset voltage temperature coefficient	-	10	-	$\mu\text{V}/^{\circ}\text{C}$	
Output low (sinking 1mA)	-	0.85	-	V	
Output high (sourcing 0.1mA)	4.7	-	-	V	
Output impedance	-	5	-	k $\Omega$	
Common mode range	1	-	2.8	V	
<b>Comparator section</b>					
Common mode range	1	-	4.3	V	
Delay to output drive ( $\pm 50\text{mV}$ input)	-	0.17	0.3	$\mu\text{s}$	
Delay to output drive ( $\pm 10\text{mV}$ input)	-	0.2	-	$\mu\text{s}$	
Input bias current	-	1	4	$\mu\text{A}$	
Input offset current	-	0.2	2	$\mu\text{A}$	
<b>Reference section</b>					
Reference voltage (at 1mA source)	2.4	2.55	2.7	V	See Notes 3 and 4
Temperature coefficient	-	50	-	ppm/ $^{\circ}\text{C}$	
Output impedance	-	1.5	-	$\Omega$	
<b>Mode control section</b>					
Single ended operation control input logic '1' (outputs 1A and 1B)	2.4	-	-	V	May be connected direct to $V_{cc}$
Push pull operation control input logic '0' (all outputs)	-	-	0.4	V	0V or left open circuit
<b>Cross couple inhibits section</b>					
Input logic '1' enables outputs	-	0.07	0.2	mA	See Note 5
Input logic '0' inhibits outputs	-	-	0.4	V	
<b>Oscillator section</b>					
Maximum frequency range	$5 \times 10^{-4}$	-	500	kHz	Minimum value of $C_T = 1500\text{pF}$
Initial accuracy	-	2	-	%	$R_T C_T$ constant
Temperature stability	-	1	-	%	Over temperature range $-55^{\circ}\text{C}$ to $+125^{\circ}\text{C}$
Output pulse width	-	0.3	-	$\mu\text{s}$	$C_T = 1500\text{pF}$
Output logic '0' (sinking 10mA)	-	-	0.4	V	Buffered output pin 24
Output logic '1' (sourcing 1mA)	2.4	-	-	V	Buffered output in 24
<b>Output section</b>					
Output current	-	$\pm 60$	-	mA	Each output 100mA max. under short circuit conditions
Output logic '0' (sinking 60mA)	-	0.4	0.45	V	
Output logic '1' (sourcing 60mA)	1.0	1.45	-	V	
<b>Total standby current</b>					
$V_{cc}$ at 2.5V, output current 4mA	-	17	-	mA	Operation from $V_{REF}$ to $V_{cc}$ is permissible
$V_{cc}$ at 5V, with outputs open	-	40	-	mA	

NOTES

1. Decouple pin 3 to GND with 0.22microfarads as close to pins 3 and 10 as possible.
2. Pin 10 GND for 5V regulator and output buffers.
3. Decouple pin 8 to GND with 0.22microfarads minimum as close to pins 8 and 16 as possible.  $V_{REF}$  will supply 1mA maximum without additional bias. Maximum sink current is 10mA.
4. Pin 16 GND for oscillator, ramp generator, comparator, amplifiers and 2.5V reference.
5. The inhibit logic 1 current is the source current required to ensure digitally high operation. The base ground resistor is nominally 10kOhms. Catching diodes to the 5V rail are included on-chip.

**ABSOLUTE MAXIMUM RATINGS**

Electrical (at -55°C to +70°C)	
Supply current (I <sub>CC</sub> )	200mA
Main output drive currents	160mA total
Clock output current (sink)	25mA
Reference current (sink)	10mA
Ramp control current	1mA
Bias sourcing current	1mA
Thermal	
Operating temperature range:	
ZN1066J	-55°C to +125°C
ZN1066E	-40°C to +85°C
Storage temperature range	-65°C to +150°C

**CIRCUIT DESCRIPTION**

The ZN1066 incorporates shunt regulators which provide a 2.6V stable reference and a 5V stabilised rail.

The on-chip oscillator is externally programmable to give a period in the range 2 seconds to 2 microseconds. Also, it may be synchronised to an external clock by means of the OSCILLATOR SYNC input.

Pulse width modulation is carried out by a ramp generator

and comparator circuit. Maximum and minimum pulse widths are easily programmed with resistors.

Two uncommitted, wideband, differential input voltage amplifiers are available on this device. They can be used for loop stabilisation, current and voltage control, current limiting and opto-isolation techniques.

In order to prevent output voltage overshoots and magnetising current imbalances in the power transformer primary a soft start function is required. This forces the output duty cycle to increase gradually following system power up or an inhibit command. A soft start and an inhibit function are easily implemented on the ZN1066.

Automatic overlap control is provided by the control logic. This removes the requirement for dead time settings, and allows up to 100% output pulse widths. This ensures that the conflict between safe minimum off time and maximum control range no longer exists.

The ZN1066 provides four push-pull totem pole type outputs. This is the most flexible and versatile output configuration available. Each is capable of sinking or sourcing 60mA. They may be paralleled in order to provide increased drive.

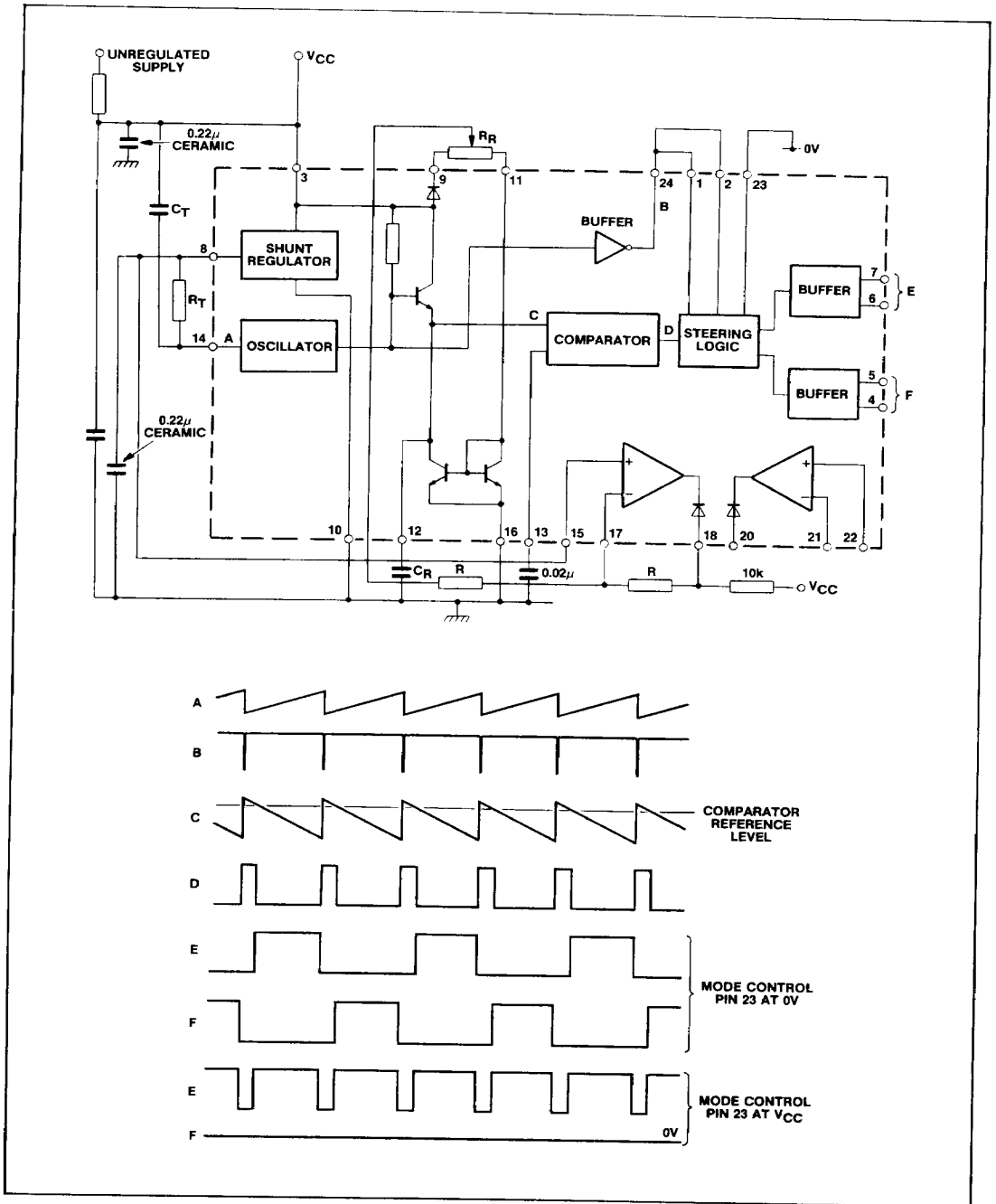

Fig.3 Open loop test circuit and system waveforms