

## FEATURES

- **Complete PC telephony solution**
  - Controller-based, robust platform
  - Exceeds Microsoft® PC 95 requirements
  - Full-duplex, echo-cancelled digital speakerphone
  - ITU (International Communications Union) V.80 videoconferencing
  - ITU-V.70 DSVD (digital simultaneous voice and data) upgrade option
  - International telephony support
- **Data modulation**
  - US Robotics® x2™ Technology
  - ITU-V.34 (33,600 to 2400 bps) symmetric and asymmetric operation
  - ITU-V.32 bis, V.23, V.22 bis, V.21
  - Bell® 212A and 103
- **Fax modulation**
  - ITU-T V.17, V.29 to 14,400 bps
- **Voice coder**
  - Voice compression: ADPCM, linear, and CL1
  - 4800, 7200, 8000, 9600, and 11025 samples per second
- **Data link layer protocols**
  - Error correction: ITU-V.42 and MNP® 2–4
  - Data compression: ITU-V.42 bis and MNP® 5
- **DTE integrated interface alternatives**
  - Serial RS-232/V.24 interface

(cont. next page)

## V.34 FastPath™ 56K Data/Fax/Voice Chipset Family

## OVERVIEW

The CL-MD56XX chipset family is a software-upgradable 56K solution with a complete set of industry-standard voice, data, and fax features. The US Robotics® x2™ Technology provides effective data receive rates of up to 53.33 kbps and ensures interoperability with major Internet service providers around the world. Chipset features include simultaneous voice and data operation, ITU-V.80 videoconferencing, and full-duplex speakerphone.

### Integrated, Open Architecture

The CL-MD56XX is based on the FastPath platform, which comprises an open-architecture ARM (Advanced RISC Machines) controller and a proprietary high-MIPS DSP (digital signal processor). Each component is highly integrated using Cirrus Logic's state-of-the-art process technology. The result is a platform with low power requirements and high performance. The FastPath plat-

(cont. next page)

## System Block Diagram

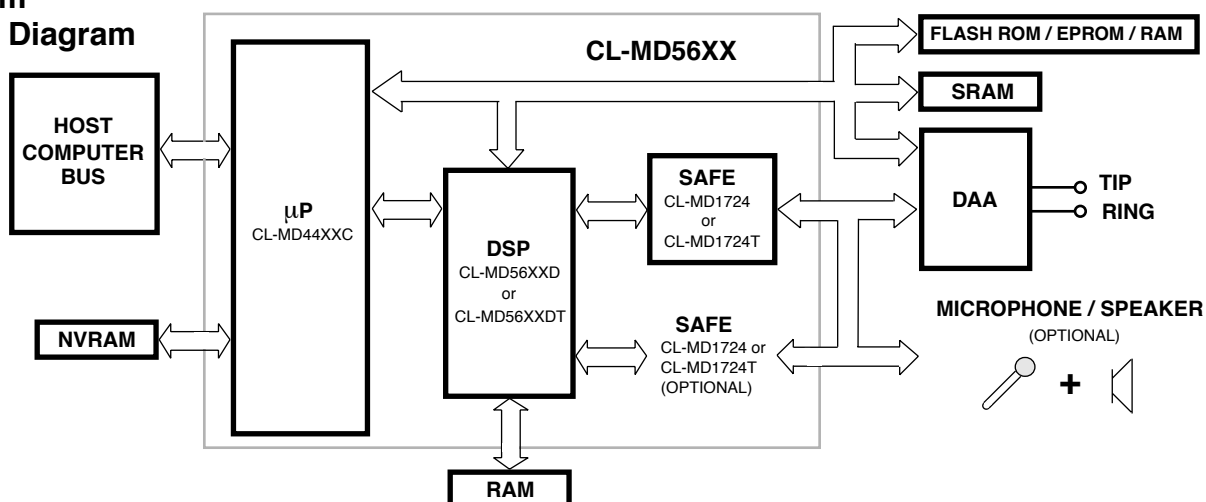

## FEATURES (cont.)

- ISA bus direct or plug and play
- PC Card bus interface
- **Voice telephony**
  - Full-duplex, echo-cancelled digital speakerphone
  - Telephone emulation for headset applications
  - Radish® VoiceView™ upgrade option
  - Microsoft® Windows® TAPI-compliant
  - ITU-V.70 DSVD upgrade option
- **Controller functionality**
  - Industry-standard AT command-driven
  - Class 1 fax
- IS-101 voice commands
- **Minimal-component design**
  - Direct connection to ISA bus
  - Single crystal
  - Passive hybrid
- **Low power requirements**
  - Single +5-V power source; 3.3-V DSP option
  - Automatic sleep and wake-up modes
- **Small package options**
  - Controller and DSP: 128-pin SQFP or VQFP packages

## OVERVIEW (cont.)

form's scalability allows the graceful addition of computer telephony features such as DSVD, speakerphone, and telephone emulation. The FastPath platform is equally suitable for both mobile and desktop solutions due to its integrated PC Card (PCMCIA), plug-and-play, and serial interfaces. Additionally, the CL-MD56XX exceeds Microsoft® PC 95 specifications for Windows® and legacy applications.

### Satisfies Legacy Applications

The CL-MD56XX supports all requirements for PC-based communications, whether for internal, standalone, or PC Card applications. With its robust controller and powerful DSP, the CL-MD56XX supports even the most demanding MS-DOS® gaming applications. The CL-MD56XX supports all industry-standard AT commands for data, IS-101 voice, and Class 1 fax.

### Versatile 56K Platform

The CL-MD56XX offers data receive speeds at up to 56 kbps using US Robotics x2 Technology. Current restrictions by the Federal Communications Commission limit actual data receive speeds to 53.33 kbps. Products can be designed for complete software upgradability or ROM chip upgrades. The CL-MD56XX is expected to support any eventual ITU 56-kbps standard.

### Comprehensive Telephony Features

Voice telephony is becoming increasingly important in modem-based products. The CL-MD56XX has a complete telephony interface (including Caller ID and voice mail) and answering machine capabilities (including call progress detection and tone generation).

For more advanced voice features, the CL-MD56XX adds telephone emulation for headset applications and

is upgradable with Radish® VoiceView™ for alternate transfers of voice and data over the same connection. The DSVD upgrade option enables data transfer in realtime during a voice conversation, an essential for whiteboard applications and sophisticated customer support. Additionally, the full-duplex, echo-cancelled digital speakerphone offers the latest technology for hands-free computer telephony. The speakerphone operates in all modes, including DSVD. All voice features are fully compliant with Microsoft Unimodem V and TAPI standards, and all voice commands comply with IS-101 voice command standards.

### International Telephony Support

The CL-MD56XX chipsets support international applications for PC Card, ISA, and serial bus designs, and Cirrus Logic also provides international DAA (data access arrangement) design recommendations. Cirrus Logic's configuration utility enables easy customization of firmware for international requirements.

### Platform of the Future

The CL-MD56XX is a solid base for future innovation. The unique caching architecture in the controller's embedded RISC processor enables the use of lower-cost memory chips. The controller code can be modified in a C-language development environment, and the flash memory interface permits field software upgrades.

The DSP delivers the bandwidth to handle multiple tasks simultaneously and to support specialized functions. Many advanced features are already built-in, including a DSVD vocoder and a full-duplex, echo-cancelled speakerphone. Concurrent operation is enabled for even the most advanced features, such as speakerphone operation in DSVD mode.

---

## PRODUCT CONFIGURATION OPTIONS

The standard features of each chipset are listed in the following table.

Feature Set	Parallel/Serial Host Interface	PC Card Host Interface	Program Memory Options	Buffer Memory (SRAM)	DSP Memory
Data/fax/voice	CL-MD5650	CL-MD5651T	two 256K × 8; 70 ns	32K × 8; 25 ns	two 32K × 8; 12 ns
Data/fax/voice with speakerphone	CL-MD5652	CL-MD5653T			
Data/fax/voice with ITU-V.70 DSVD upgrade option and speakerphone	CL-MD5662T	CL-MD5663T			

---

## COMPLETE DESIGN GUIDELINES

### Reference Designs Available

Cirrus Logic provides reference designs for use and modification by customers. These designs demonstrate chipset applications for several common configurations. The design documentation includes schematics, bills of materials, fabrication drawings, and MS-DOS- or Windows®-based OrCAD® files.

### Simple Software Upgrades

End users can easily download and install upgrades of 56K software from manufacturer-supported Internet sites. The use of flash memory permits these field upgrades. Additional program memory is required to support the 32 Kbytes of RAM needed for 56K operation and a full feature set.

### Complete Telephony Interface Design

A proprietary telephone interface design is included in each reference design provided to all Cirrus Logic customers. The telephony interface supports Caller ID and

19 modes related to voice features. Seven of these modes provide basic voice features and three modes support DSVD operation.

### Minimal-Component Design

Besides the SRAM and flash or ROM components listed above, only a single crystal and 2 Kbytes of NVRAM (non-volatile RAM) are required to complete the designs. No additional components are needed to add ISA bus interface, plug-and-play, speakerphone, or DSVD features. The I/O interface circuit does require relay support for Caller ID and telephony features.

### Reduced EMI/RFI Emissions

A single crystal serves as a clock for both the controller and DSP in the CL-MD56XX chipsets. Besides reducing cost, the single-crystal design minimizes high-frequency harmonics and simplifies EMI/RFI design considerations.

---

## DESIGN KITS AND SUPPORTING DOCUMENTATION

The following table details the contents of reference design kits and documentation.

Kit / Document	Contents
<b>56K ISA Half Card Kit</b> <b>MDK56SPD-2IXX</b> Includes international DAA interface and an audio/voice hardware interface	<ul style="list-style-type: none"> <li>● ISA half card</li> <li>● CL-MDK56XX-XX Applications Book</li> <li>● Commercial software</li> <li>● Modem utilities disk (including .INF file and drivers)</li> </ul>
<b>56K ISA Combo Card Kit</b> <b>MDK56A37-1CXX</b> Based on Crystal's CS4236 audio solution	<ul style="list-style-type: none"> <li>● ISA combo card</li> <li>● CL-MDK56XX-XX Applications Book</li> <li>● Audio and communication drivers</li> <li>● Commercial software</li> <li>● Modem utilities disk (including .INF file and drivers)</li> </ul>
<b>56K PC Card (PCMCIA) Kit</b> <b>MDK56-0PXX</b> Includes Caller ID and all voice features, including DSVD on a headset interface	<ul style="list-style-type: none"> <li>● PC Card</li> <li>● Interface cable</li> <li>● CL-MDK56XX-XX Applications Book</li> <li>● Commercial software</li> <li>● Modem utilities disk (including .INF file and drivers)</li> </ul>
<b>56K Serial Box Modem Kit</b> <b>MDK56SPD-5SXX</b> Includes Caller ID and all voice features, including DSVD	<ul style="list-style-type: none"> <li>● Serial PC Card</li> <li>● CL-MDK56XX-XX Applications Book</li> <li>● Commercial software</li> <li>● Modem utilities disk (including .INF file and drivers)</li> </ul>
<b>CL-MDK56XX-XX Applications Book</b>	<ul style="list-style-type: none"> <li>● CL-MDK56XX Data Book</li> <li>● CL-MD56XX Programmer's Guide</li> <li>● Support documentation:               <ul style="list-style-type: none"> <li>— Demonstration Board Design Considerations Application Alert</li> <li>— CL-MDK56SPD-2I01 Half Card 56K Hardware Application Note</li> <li>— CL-MDK56A37-1C01 ISA 56K Combo Card Hardware Application Note</li> <li>— CL-MDK56-OP01 PC Card 56K Hardware Application Note</li> <li>— CL-MDK56SPD-5SXX Serial Box 56K Modem Hardware Application Note</li> <li>— Use of Microphones with V.34 FastPath™ Chipsets</li> <li>— Modem PCB Layout Guidelines</li> <li>— Windows® 95 .INF File User's Guide</li> <li>— 56K Upgrading Instructions</li> <li>— Installation Instructions for the International Configuration Utility</li> <li>— Class 1 Fax Application Note</li> <li>— IS-101 Voice Application Note</li> </ul> </li> </ul>

**NOTE:** For information on availability, please contact your local Cirrus Logic representative.

## ORDERING INFORMATION

### Chipset Composition

The following table gives a brief description of each chipset and a list of its parts.

Market	Parallel/Serial Host Interface	PC Card Host Interface
Data/fax/voice	<p style="text-align: center;"><b>CL-MD5650</b></p> <pre> graph TD     CLMD5650[CL-MD5650] --- U1[μP CL-MD4450C]     CLMD5650 --- D1[DSP CL-MD5650D]     CLMD5650 --- S1[SAFE CL-MD1724]                     </pre>	<p style="text-align: center;"><b>CL-MD5651T</b></p> <pre> graph TD     CLMD5651T[CL-MD5651T] --- U2[μP CL-MD4451C]     CLMD5651T --- D2[DSP CL-MD5651DT]     CLMD5651T --- S2[SAFE CL-MD1724T]                     </pre>
Data/fax/voice, full-duplex speaker-phone	<p style="text-align: center;"><b>CL-MD5652</b></p> <pre> graph TD     CLMD5652[CL-MD5652] --- U3[μP CL-MD4450C]     CLMD5652 --- D3[DSP CL-MD5650D]     CLMD5652 --- S3_1[SAFE CL-MD1724]     CLMD5652 --- S3_2[SAFE CL-MD1724]                     </pre>	<p style="text-align: center;"><b>CL-MD5653T</b></p> <pre> graph TD     CLMD5653T[CL-MD5653T] --- U4[μP CL-MD4451C]     CLMD5653T --- D4[DSP CL-MD5651DT]     CLMD5653T --- S4_1[SAFE CL-MD1724T]     CLMD5653T --- S4_2[SAFE CL-MD1724T]                     </pre>
Data/fax/voice, full-duplex speaker-phone, DSVD	<p style="text-align: center;"><b>CL-MD5662T</b></p> <pre> graph TD     CLMD5662T[CL-MD5662T] --- U5[μP CL-MD4450C]     CLMD5662T --- D5[DSP CL-MD5660DT]     CLMD5662T --- S5_1[SAFE CL-MD1724T]     CLMD5662T --- S5_2[SAFE CL-MD1724T]                     </pre>	<p style="text-align: center;"><b>CL-MD5663T</b></p> <pre> graph TD     CLMD5663T[CL-MD5663T] --- U6[μP CL-MD4451C]     CLMD5663T --- D6[DSP CL-MD5660DT]     CLMD5663T --- S6_1[SAFE CL-MD1724T]     CLMD5663T --- S6_2[SAFE CL-MD1724T]                     </pre>

### Part Identification

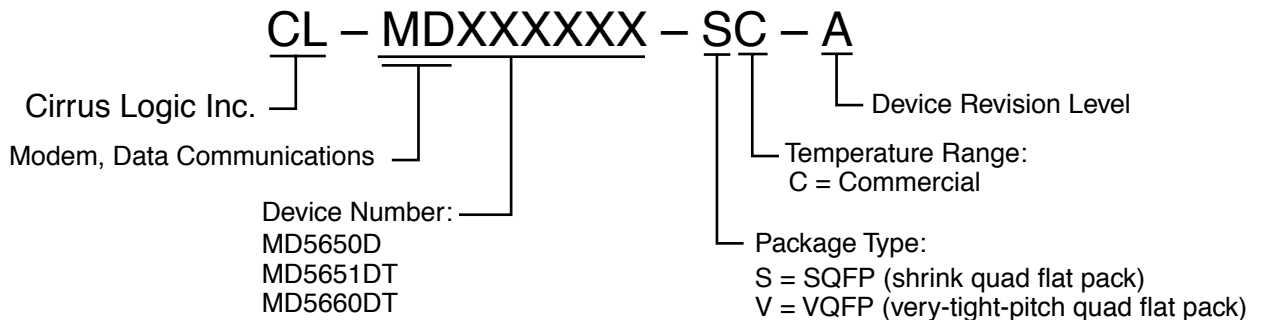



## Direct Sales Offices

### Domestic

#### N. CALIFORNIA

Fremont  
TEL: 510/623-8300  
FAX: 510/252-6020

#### S. CALIFORNIA

Westlake Village  
TEL: 805/371-5860  
FAX: 805/371-5861

#### NORTHWESTERN AREA

Portland, OR  
TEL: 503/620-5547  
FAX: 503/620-5665

#### SOUTH CENTRAL AREA

Austin, TX  
TEL: 512/255-0080  
FAX: 512/255-0733

Irving, TX  
TEL: 972/252-6698  
FAX: 972/252-5681

Houston, TX  
TEL: 281/257-2525  
FAX: 281/257-2555

#### NORTHEASTERN AREA

Andover, MA  
TEL: 508/474-9300  
FAX: 508/474-9149

#### SOUTHEASTERN AREA

Raleigh, NC  
TEL: 919/859-5210  
FAX: 919/859-5334

Boca Raton, FL  
TEL: 407/241-2364  
FAX: 407/241-7990

### International

#### CHINA

Beijing  
TEL: 86/10-642-807-83-5  
FAX: 86/19-672-807-86

#### FRANCE

Paris  
TEL: 33/1-48-12-2812  
FAX: 33/1-48-12-2810

#### GERMANY

Herrsching  
TEL: 49/81-52-92460  
FAX: 49/81-52-924699

#### HONG KONG

Tsimshatsui  
TEL: 852/2376-0801  
FAX: 852/2375-1202

#### ITALY

Milan  
TEL: 39/2-3360-5458  
FAX: 39/2-3360-5426

#### JAPAN

Tokyo  
TEL: 81/3-3340-9111  
FAX: 81/3-3340-9120

#### KOREA

Seoul  
TEL: 82/2-565-8561  
FAX: 82/2-565-8565

#### SINGAPORE

TEL: 65/743-4111  
FAX: 65/742-4111

#### TAIWAN

Taipei  
TEL: 886/2-718-4533  
FAX: 886/2-718-4526

#### UNITED KINGDOM

London, England  
TEL: 44/1727-872424  
FAX: 44/1727-875919

## The Company

Headquartered in Fremont, California, Cirrus Logic is a leading manufacturer of advanced integrated circuits for desktop and portable computing, telecommunications, and consumer electronics. The Company applies its system-level expertise in analog and digital design to innovate highly integrated, software-rich solutions.

Cirrus Logic has developed a broad portfolio of products and technologies for applications spanning multimedia, graphics, communications, system logic, mass storage, and data acquisition.

The Cirrus Logic formula combines innovative architectures in silicon with system design expertise. We deliver complete solutions — chips, software, evaluation boards, and manufacturing kits — on-time, to help you win in the marketplace.

Cirrus Logic's manufacturing strategy ensures maximum product quality, availability, and value for our customers.

Talk to our systems and applications specialists; see how you can benefit from a new kind of semiconductor company.

Copyright © 1997 Cirrus Logic Inc. All rights reserved.

Preliminary product information describes products that are in production, but for which full characterization data is not yet available. Cirrus Logic Inc. has made best efforts to ensure that the information contained in this document is accurate and reliable. However, the information is subject to change without notice. No responsibility is assumed by Cirrus Logic Inc. for the use of this information, nor for infringements of patents or other rights of third parties. This document implies no license under patents, copyrights, or trade secrets. Cirrus Logic, AccuPak, Clear3D, DirectVPM, DIVA, FastPath, FasText, FeatureChips, FilterJet, Get into it, Good Data, Laguna3D, MediaDAC, MotionVideo, RSA, SimulSCAN, S/LA, SMASH, SofTarget, Systems in Silicon, TextureJet, TVTap, UXART, Video Port Manager, VisualMedia, VPM, V-Port, Voyager, WavePort, and WebSet are trademarks of Cirrus Logic Inc., which may be registered in some jurisdictions. Other trademarks in this document belong to their respective companies. CRUS and Cirrus Logic International, Ltd. are trade names of Cirrus Logic Inc.

**Cirrus Logic Inc.**  
3100 West Warren Ave., Fremont, CA 94538  
TEL: 510/623-8300 FAX: 510/252-6020

**Publications Ordering:** 800/359-6414 (USA) or 510/249-4200  
**World Wide Web:** <http://www.cirrus.com>

555699-002