

October 3, 2000

TEL:805-498-2111 FAX:805-498-3804 WEB:http://www.semtech.com

## DESCRIPTION

The SC1517-5 is pin compatible with LTC1517-5. This versatile charge pump produces a regulated 5V output from an input voltage ranging from 2.7V to 5V. The Extremely low operating current (typically 10µA with no load) prolongs battery usage time. The small device footprint and the low external parts count (one 0.1µF flying capacitor and two small bypass capacitors at  $V_{IN}$  and  $V_{OUT}$ ) make the part ideally suited for compact circuit design.

The SC1517-5 charge pump can be used for applications that require up to 20mA ( $3V \leq V_{IN} \leq 5V$ ) of output current, while providing a regulated 5V output voltage. During short circuit a current limit circuitry provides protection, while the thermal shutdown capability cycles  $V_{OUT}$  to prevent device failure. The SC1517-5 is available in a 5 lead SOT-23 package.

## FEATURES

- Ultra low power:  $I_{CC} = 10\mu A$  typ
- Soft start / Short circuit Current limit
- Thermal protected
- $5V \pm 4\%$  Regulated output
- $V_{IN}$  Range: 2.7V to 5V
- Output current:  
10mA ( $V_{IN} \geq 2.7V$ )  
20mA ( $V_{IN} \geq 3V$ )
- No inductors
- Ultra small application circuit
- 800kHz switching frequency
- Surface mount packaging (5 pin SOT-23)
- All specifications rated over full temperature range (-40°C to 85°C)

## APPLICATIONS

- Cellular telephones
- Battery-operated equipment
- Local power supplies
- Handheld instruments
- PCMCIA supplies

## ORDERING INFORMATION

Device <sup>(1)</sup>	Package	Temp. Range ( $T_A$ )
SC1517ISK-5.TR	SOT-23-5	-40° to 85°C

Notes:

(1) Only available in tape and reel packaging. A reel contains 3000 devices

## TYPICAL APPLICATION SCHEMATIC

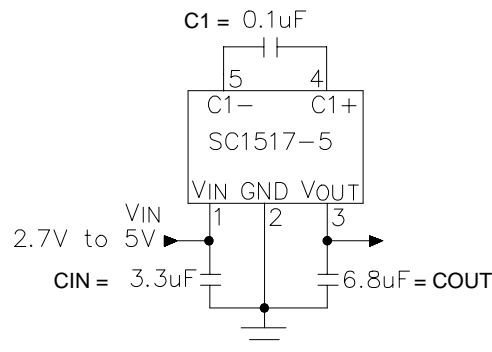

$$V_{OUT} = 5V \pm 4\%$$

$$I_{OUT} = 10mA \quad (V_{IN} \geq 2.7V)$$

$$I_{OUT} = 20mA \quad (V_{IN} \geq 3V)$$

### Note :

Ceramic capacitors used for improved performance, Low ESR Tantalum with ESR &lt; 0.5 Ohms could also be used.

October 3, 2000

**ABSOLUTE MAXIMUM RATINGS**

Parameter	Symbol	Maximum	Units
Input Supply Voltage	$V_{in}$	-0.3 to 6	V
Output Supply Voltage	$V_{out}$	-0.3 to 6	V
Power Dissipation	$P_d$	391	mW
Thermal Resistance	$\theta_{JA}$	256	°C/W
Operating Ambient Temperature Range	$T_A$	-40 to +85	°C
Operating Junction Temperature Range	$T_J$	-40 to +125	°C
Storage Temperature Range	$T_{STG}$	-65 to +150	°C
Lead Temperature (Soldering) 10 Sec	$T_{LEAD}$	+300	°C
ESD Rating (Human Body Model)	ESD	2	kV

**ELECTRICAL CHARACTERISTICS**

 Unless specified:  $T_A = -40^{\circ}\text{C}$  to  $85^{\circ}\text{C}$ ,  $V_{IN} = 2.7\text{V}$  to  $5\text{V}$ ,  $C_1 = 0.1\mu\text{F}$ ,  $C_{IN} = 3.3\mu\text{F}$ ,  $C_{OUT} = 6.8\mu\text{F}$ .

Parameter	Symbol	Conditions	Min	Typ	Max	Units
Operating Input Voltage	$V_{IN}$		2.7		5	V
Output Voltage	$V_{OUT}$	$2.7\text{V} \leq V_{IN} \leq 5\text{V}$ , $I_{OUT} \leq 10\text{mA}$	4.8	5.0	5.2	V
		$3\text{V} \leq V_{IN} \leq 5\text{V}$ , $I_{OUT} \leq 20\text{mA}$	4.8	5.0	5.2	V
Input Supply Current	$I_{CC}$	$2.7\text{V} \leq V_{IN} \leq 5\text{V}$ , $I_{OUT} = 0$		10	15	$\mu\text{A}$
$V_{OUT}$ Ripple (pk-pk) <sup>(1)(2)</sup>	$V_R$	$V_{IN} = 3\text{V}$ , $I_{OUT} = 20\text{mA}$ , $C_{OUT} = 6.8\mu\text{F}$		75		mV <sub>P-P</sub>
Oscillator Frequency <sup>(1)(2)</sup>	$f_{OSC}$			800		kHz
$V_{OUT}$ Turn-On Time <sup>(1)(2)</sup>	$t_{ON}$	$V_{IN} = 3\text{V}$ , $I_{OUT} = 0\text{mA}$		1		ms
Soft start / Short circuit Current limit <sup>(1)(2)(3)</sup>	$I_{limit}$	Short circuit applied at $V_{out}$ to GND	35	65		mA

**NOTES:**

- (1) All electrical characteristics are for the application circuit on page 1.
- (2) Guaranteed by design.
- (3) Indefinite duration.

October 3, 2000

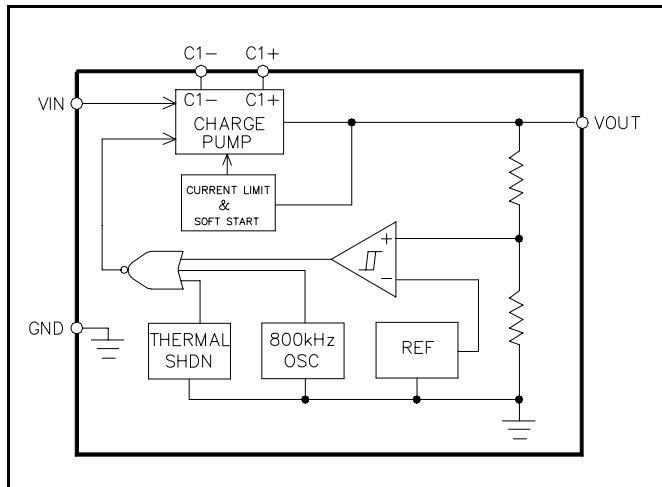
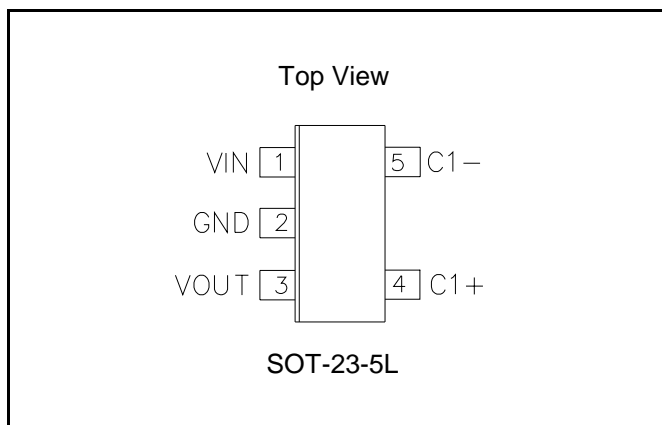
**BLOCK DIAGRAM**

**PIN CONFIGURATION**

**PIN DESCRIPTION**

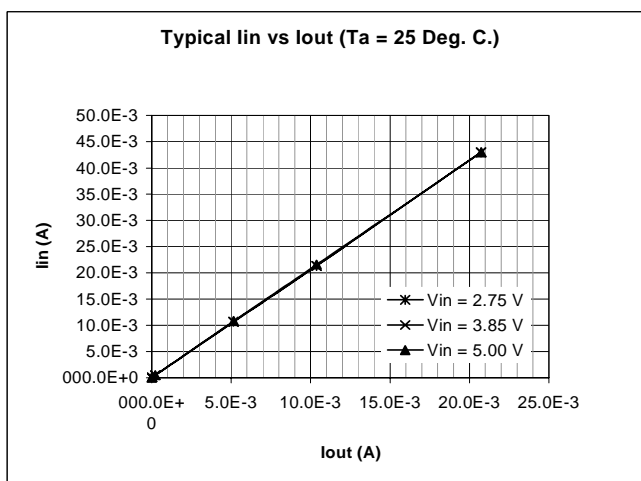
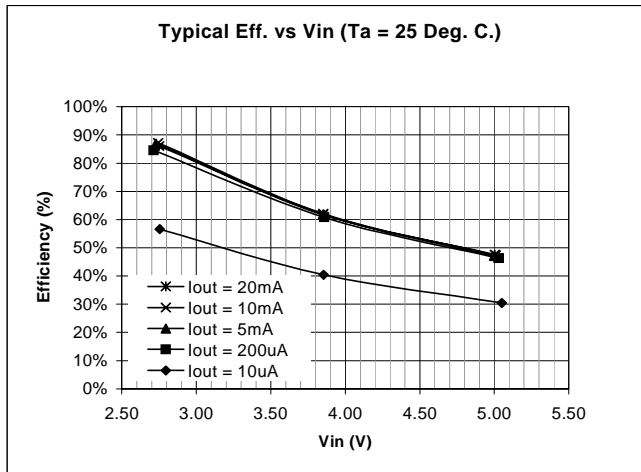
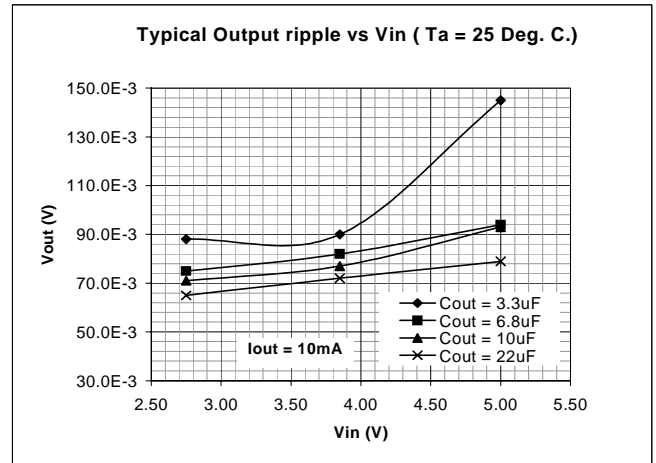
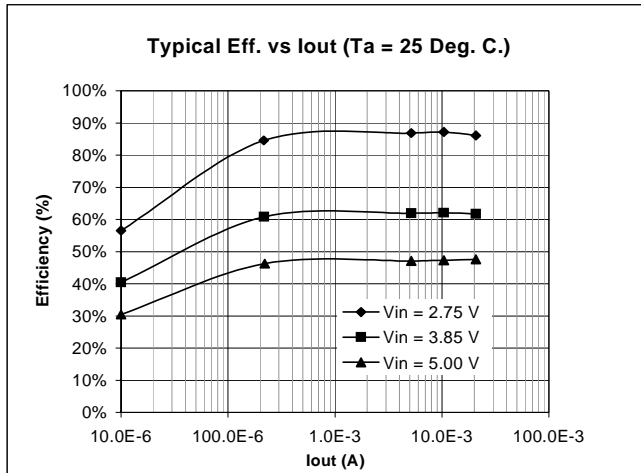
Pin #	Pin Name	Description
1	VIN	Charge pump input voltage. May be between 2.7V and 5V. $V_{IN}$ should be bypassed with a $\geq 3.3\mu\text{F}$ low ESR capacitor as close as possible to the pin for best performance.
2	GND	Ground pin.
3	VOUT	Regulated output voltage. $V_{OUT}$ should be bypassed with a $\geq 3.3\mu\text{F}$ low ESR capacitor as close as possible to the pin for best performance.
4	C1+	Charge pump flying capacitor positive terminal.
5	C1-	Charge pump flying capacitor negative terminal.

October 3, 2000

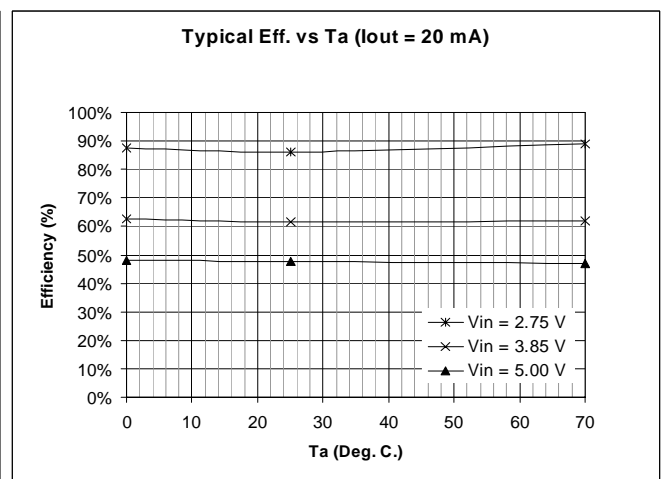
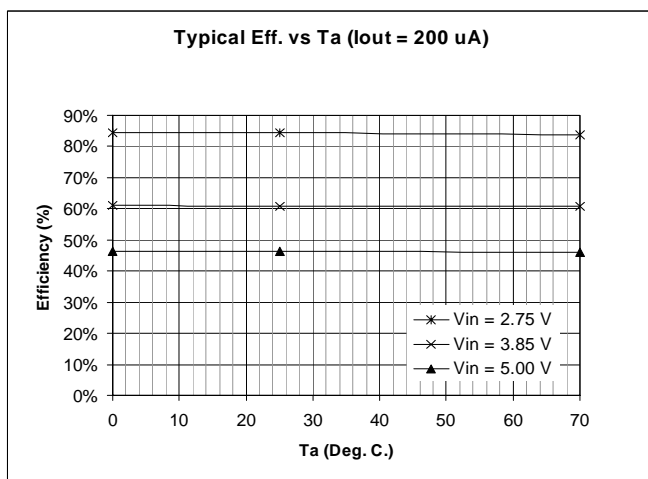
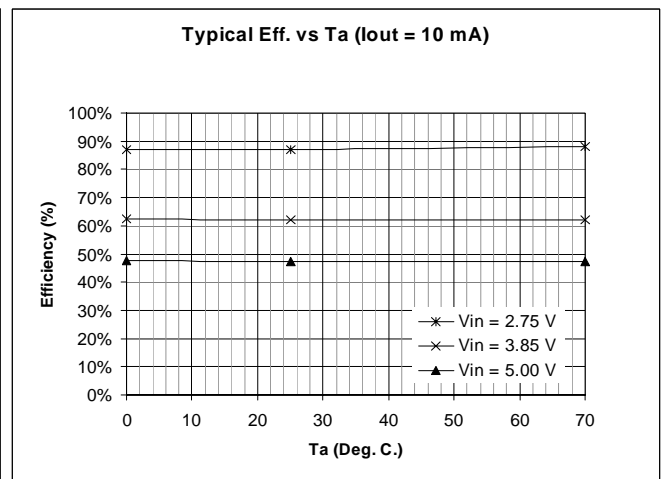
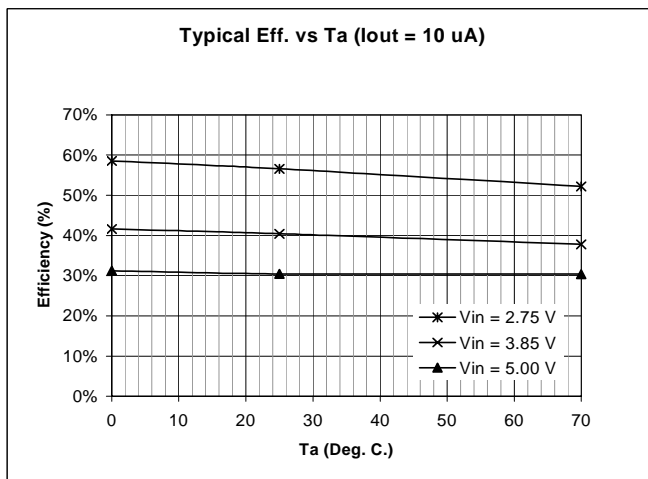
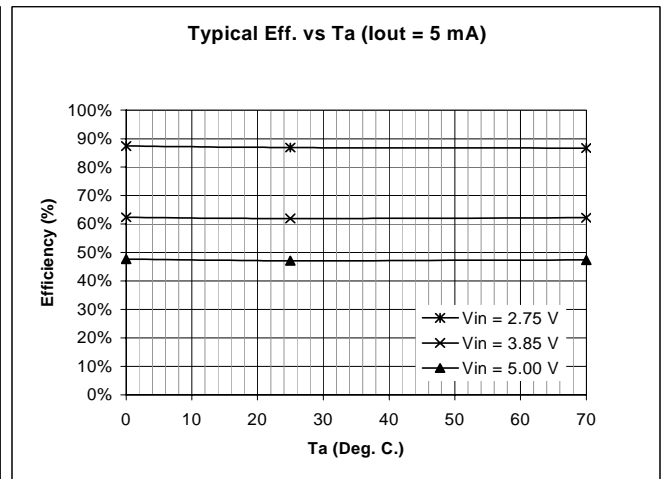
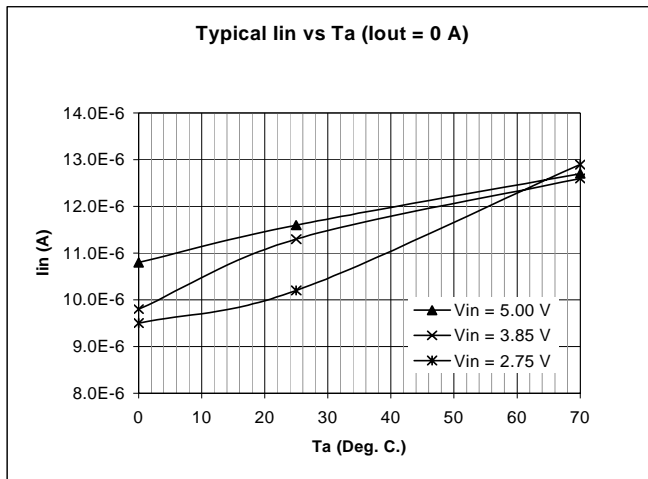

October 3, 2000



October 3, 2000

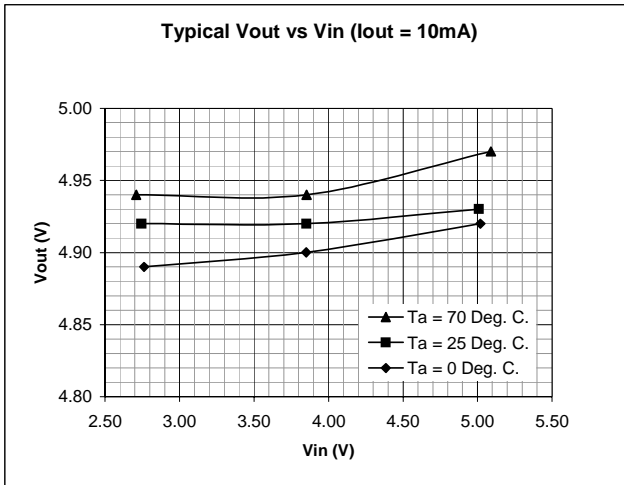

October 3, 2000

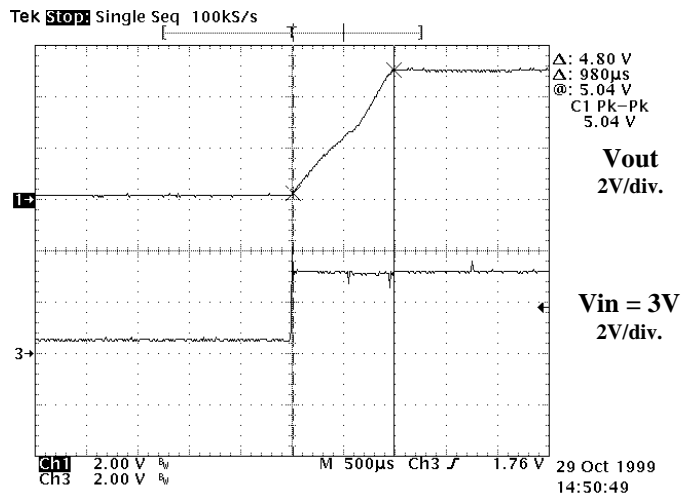

**Turn on Regulation time(Ta = 25 Deg. C.)**

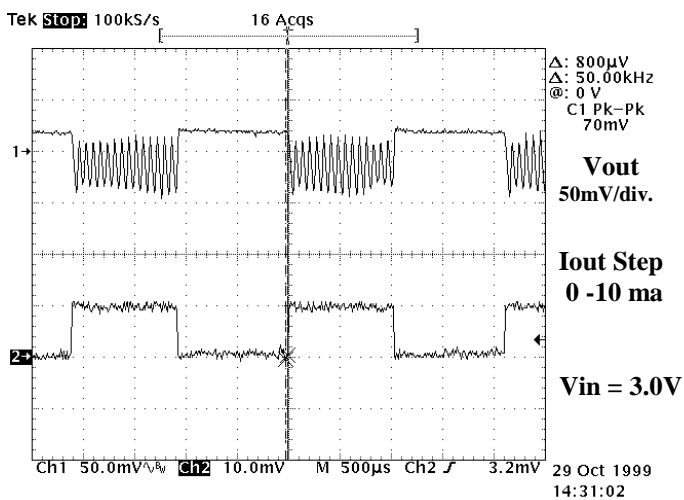

**Load Transient Response(Ta = 25 Deg. C.)**

October 3, 2000

## APPLICATION NOTES

### THEORY OF OPERATION

The SC1517-5 utilizes a switched capacitor charge pump, to generate an output voltage regulated to 5V $\pm$ 4%.

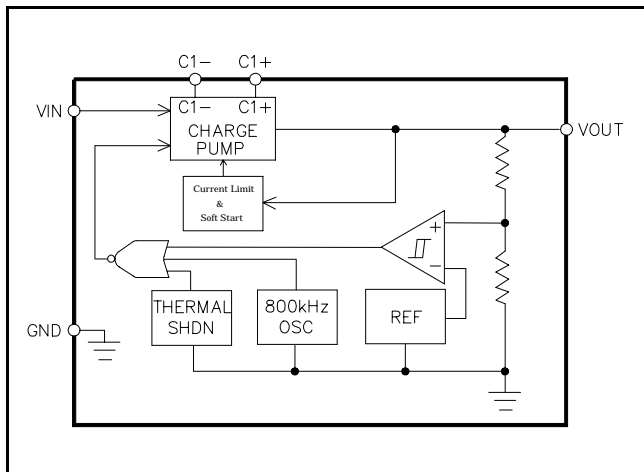

An internal oscillator generates two out of phase clock signals which turn on and off internal MOSFET switches. During phase1 of clock, the flying charge

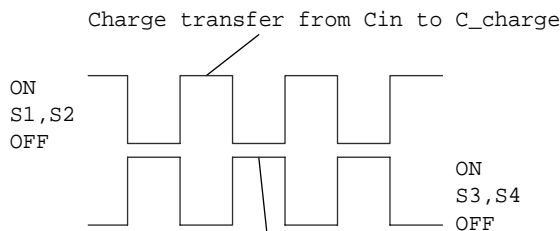

Charge transfer from (C<sub>in</sub> and C<sub>charge</sub>) to C<sub>out</sub>

pump capacitor is charged to V<sub>in</sub> through switches S1, and S2. During phase2 the flying charge pump capacitor is connected in series with the input voltage via S3, and S4, producing an output voltage.

An integrated comparator senses the output voltage

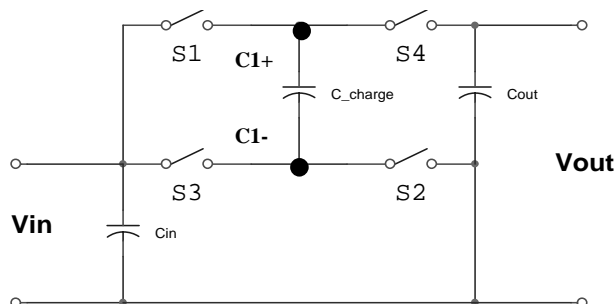

and disable the charge pump once an upper threshold is reached. As the output voltage drops below the lower threshold, the comparator enables the charge pump and hence regulation is achieved.

### SHORT CIRCUIT / SOFT START

An internal current limit and soft start circuit provides protection against output short circuit and limits large current spikes generated during the initial start up to charge output capacitor.

As the over current condition is applied at the output, a comparator senses the output voltage and compares it to a signal approximating V<sub>IN</sub> - 500mV.

If V<sub>OUT</sub> < V<sub>IN</sub> - 500mV, the comparator enables a 65mA typical limited current source and the charge pump is disabled. Once the over current is removed and V<sub>OUT</sub> > V<sub>IN</sub> - 500mV, the current source is disconnected from output and the charge pump circuitry is enabled again.

### THERMAL SHUTDOWN

The thermal shutdown circuit provides added protection to the SC1517-5. During a V<sub>OUT</sub> short circuit condition or if the load is excessive (I<sub>OUT</sub> > = 20mA), the thermal shut down circuit is active and if the junction temperature exceeds approximately 160°C, the charge pump is disabled. The charge pump is enabled only if the junction temperature drops to approximately 145°C. The SC1517-5 will cycle in and out of thermal shut down until the short circuit or the excessive load condition on V<sub>OUT</sub> is removed, thereby improving device reliability.

### V<sub>OUT</sub> RIPPLE & CAPACITOR SELECTION

The peak to peak output ripple voltage is dependent on the following factors:

- 1- Oscillator Frequency
- 2- Hysteresis window of the comparator
- 3- ESR of C<sub>Charge</sub>, and C<sub>out</sub>
- 4- Capacitance value of C<sub>out</sub>, and C<sub>Charge</sub>

Item 1, and 2 are fixed and depend on the charge pump device used. Item 3, and 4 can be optimized for best performance and reduction of the output ripple.



October 3, 2000

The following formula could be used for an approximation for  $V_{out\_ripple}$ .

$$V_{out\_ripple} = \frac{I_{out}}{2 \times F_{osc} \times C_{out}} + I_{out} \times ESR_{C_{out}}$$

Figure below shows the effect of output capacitance value on the ripple voltage. Capacitors used were multilayer ceramic with low ESR < 0.1 Ohms .

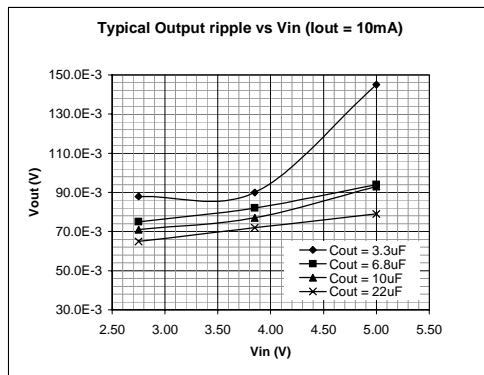

Following table shows typical capacitor characteristics :

Component	ESR (Ohms)	ESL (nH)
0.1 uF Ceramic 0603 package	0.100	1.60
1.0 uF Ceramic 1206 package	0.120	0.47
10 uF Ceramic 1206 package	0.075	0.5
47 uF, 16V Tantalum D case	0.100	0.60
330 uF, 6.3V "OSCON"	0.025	2.5
330 uF, 16V Al Electrolytic	0.143	2.37
820 uF, 4.0V "OSCON"	0.012	2.5
1000 uF, 10V Al Electrolytic	0.053	5

### Capacitor Manufacturers

Manufacturer	Phone
AVX Corp.	(803)-448-9411
VISHAY	(207)-324-4140
Nichicon Corp.	(708)-843-7500
muRata	(800)-831-9172
TOKIN	(408)-432-8020
Taiyo Yuden	(800)-348-2496
Sanyo	(619)-661-6835

### LAYOUT CONSIDERATION

Standard power board layout should followed to ensure proper operation. Any stray inductance should be minimized, this can be achieved by using large power planes or traces, and reducing the distances between input, output and the load. All components should be placed as close as possible to the SC1517-5.

October 3, 2000

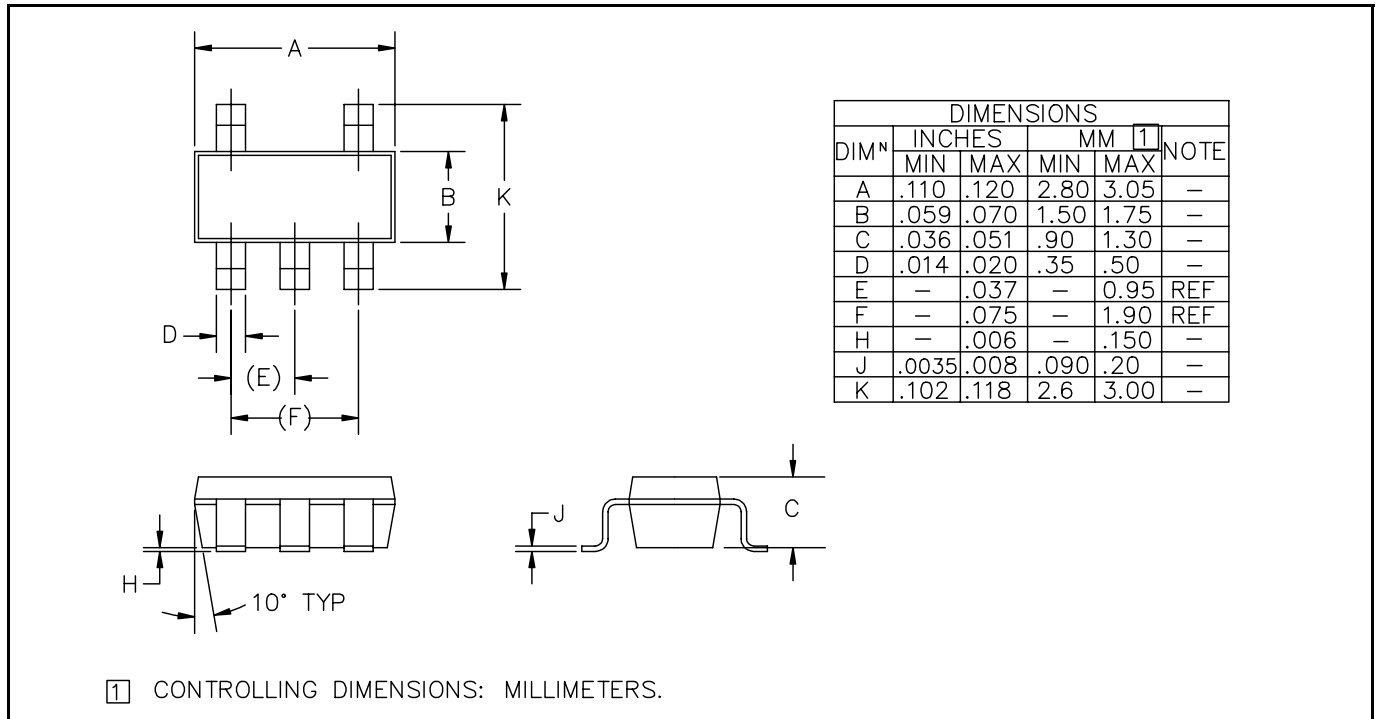
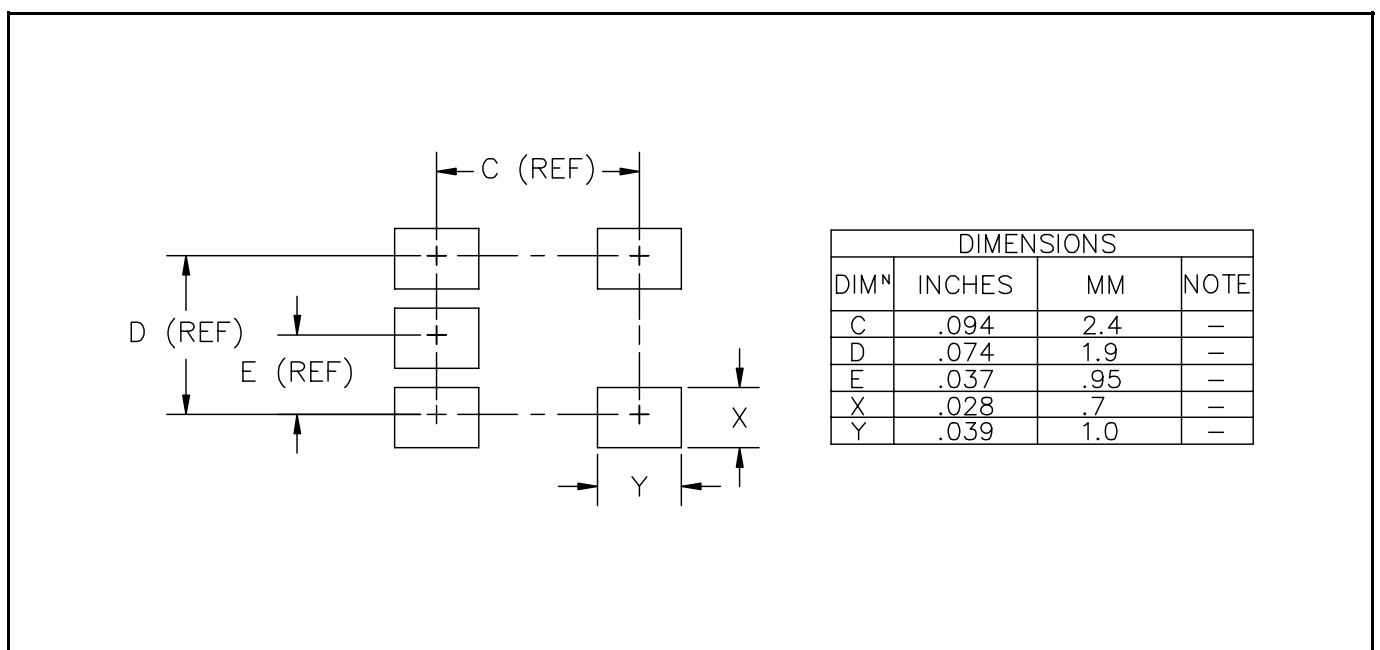
**DEVICE OUTLINE SOT23-5L**

**LAND PATTERN SOT23-5L**

ECN00-1360