

Silicon NPN Power Transistors

2SD2401

DESCRIPTION

- With MT-200 package
- Complement to type 2SB1570
- DARLINGTON

APPLICATIONS

- Audio, series regulator and general purpose applications

PINNING(see Fig.2)

PIN	DESCRIPTION
1	Base
2	Collector;connected to mounting base
3	Emitter

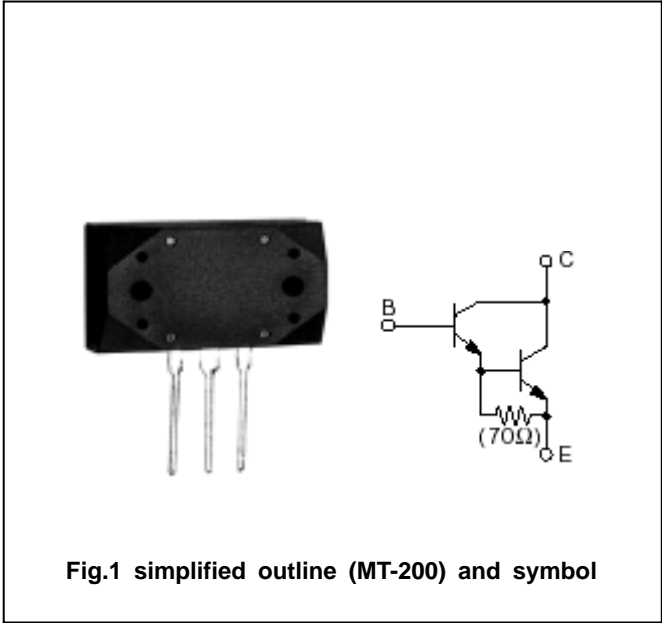

Fig.1 simplified outline (MT-200) and symbol

Absolute maximum ratings (Ta=25)

SYMBOL	PARAMETER	CONDITIONS	VALUE	UNIT
V _{CBO}	Collector-base voltage	Open emitter	160	V
V _{CEO}	Collector-emitter voltage	Open base	150	V
V _{EBO}	Emitter-base voltage	Open collector	5	V
I _C	Collector current		12	A
I _B	Base current		1	A
P _C	Collector power dissipation	T _C =25	150	W
T _j	Junction temperature		150	
T _{stg}	Storage temperature		-55~150	

Silicon NPN Power Transistors

2SD2401

CHARACTERISTICS

T_j=25 unless otherwise specified

SYMBOL	PARAMETER	CONDITIONS	MIN	TYP.	MAX	UNIT
V _{(BR)CEO}	Collector-emitter breakdown voltage	I _C =30mA; I _B =0	150			V
V _{CEsat}	Collector-emitter saturation voltage	I _C =7 A; I _B =7m A			2.5	V
V _{BEsat}	Base-emitter saturation voltage	I _C =7 A; I _B =7m A			3.0	V
I _{CBO}	Collector cut-off current	V _{CB} =160V; I _E =0			100	μ A
I _{EBO}	Emitter cut-off current	V _{EB} =5V; I _C =0			100	μ A
h _{FE}	DC current gain	I _C =7A ; V _{CE} =4V	5000			
f _T	Transition frequency	I _C =2A ; V _{CE} =12V		55		MHz
C _{OB}	Output capacitance	I _E =0; V _{CB} =10V; f=1MHz		95		pF

Switching times

t _{on}	Turn-on time	I _C =7A; R _L =10 I _{B1} =- I _{B2} =7mA V _{CC} =70V		0.5		μ s
t _s	Storage time			10.0		μ s
t _f	Fall time			1.1		μ s

◆ h_{FE} classifications

O	P	Y
5000-12000	6500-20000	15000-30000

PACKAGE OUTLINE

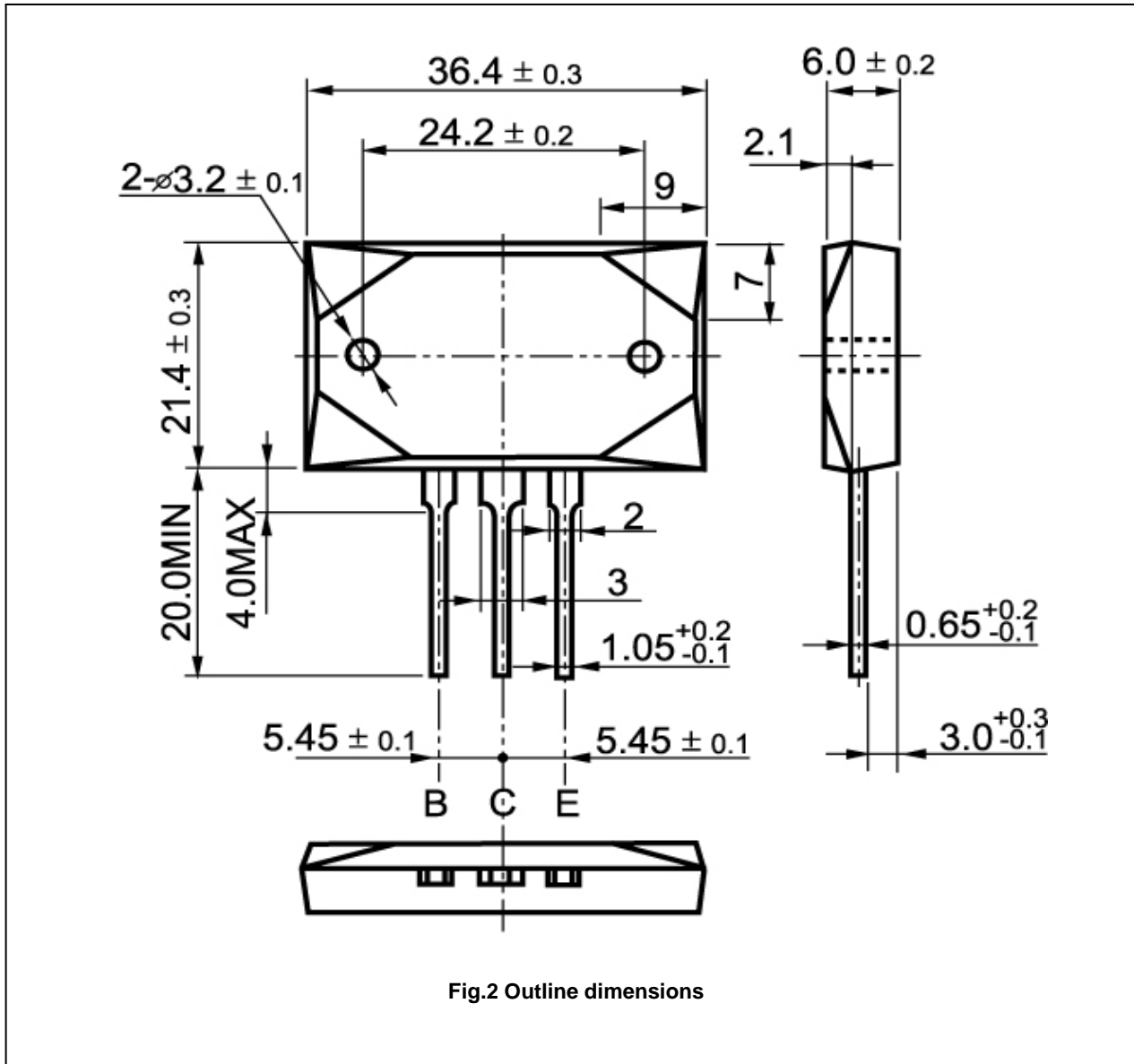

Fig.2 Outline dimensions