

PLEASE CHECK WWW.MOLEX.COM FOR LATEST PART INFORMATION

Part Number: [0674921832](#)
Status: **Active**
Overview: serial ata 127 host receptacles
Description: 1.27mm (.050") Pitch Serial ATA Host Receptacle, Right Angle, SMT, Mating Height 5.60mm (.220"), 0.38µm (15µ") Gold (Au) Plating, with Cap, Embossed Tape on Reel Packaging, 22 Circuits, Lead Free

Documents:

[3D Model](#)
[Drawing \(PDF\)](#)

[RoHS Certificate of Compliance \(PDF\)](#)

General

Product Family	PCB Receptacles
Series	67492
Application	Board-to-Board
Comments	With Cap
Overview	serial ata 127 host receptacles
Product Name	Serial ATA

Physical

Circuits (Loaded)	22
Circuits (maximum)	22
Color - Resin	Black
Durability (mating cycles max)	500
Glow-Wire Compliant	No
Guide to Mating Part	Yes
Keying to Mating Part	Yes
Lock to Mating Part	None
Mated Height (mm)	5.60 mm
Material - Metal	Copper Alloy
Material - Plating Mating	Gold
Material - Plating Termination	Tin
Material - Resin	High Temperature Thermoplastic
Number of Rows	1
Orientation	Right Angle
PCB Locator	Yes
PCB Retention	Yes
PCB Thickness Recommended (in)	0.045 In
PCB Thickness Recommended (mm)	1.20 mm
Packaging Type	Embossed Tape on Reel
Pitch - Mating Interface (in)	0.050 In
Pitch - Mating Interface (mm)	1.27 mm
Pitch - Term. Interface (in)	0.050 In
Pitch - Term. Interface (mm)	1.27 mm
Plating min: Mating (µin)	15
Plating min: Mating (µm)	0.38
Plating min: Termination (µin)	50
Plating min: Termination (µm)	1.27
Polarized to Mating Part	Yes
Polarized to PCB	Yes
Robotic Placement	Pick and Place Cap
Stackable	No
Temperature Range - Operating	-35°C to +85°C
Termination Interface: Style	Surface Mount

Electrical

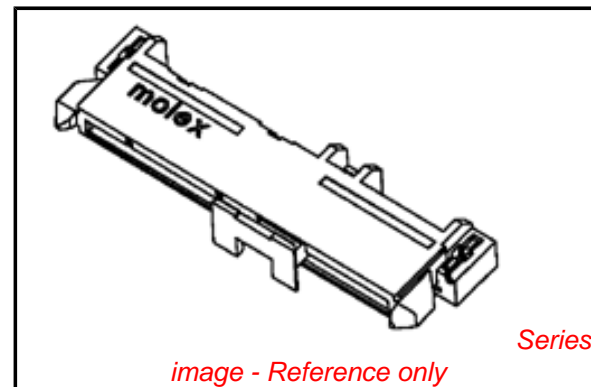

EU RoHS

ELV and RoHS Compliant
REACH SVHC
 Not Reviewed
Halogen-Free Status

China RoHS



Not Reviewed

Need more information on product environmental compliance?

Email productcompliance@molex.com
 For a multiple part number RoHS Certificate of Compliance, [click here](#)

Please visit the [Contact Us](#) section for any non-product compliance questions.

Search Parts in this Series

[67492Series](#)

Mates With

[87703](#) , [87672](#) Serial ATA Plugs

Current - Maximum per Contact	1.5A
Voltage - Maximum	15V DC

Material Info

Reference - Drawing Numbers

Packaging Specification	PK-67492-007
Sales Drawing	SD-67492-009

This document was generated on 05/31/2010

PLEASE CHECK WWW.MOLEX.COM FOR LATEST PART INFORMATION

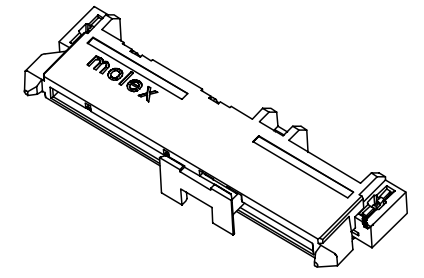
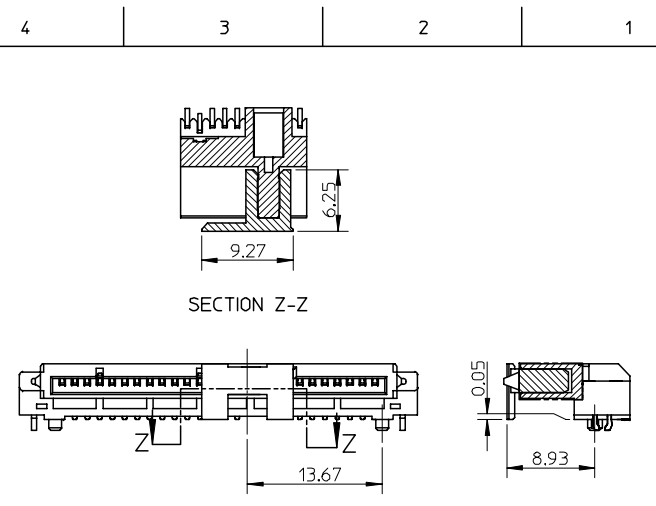
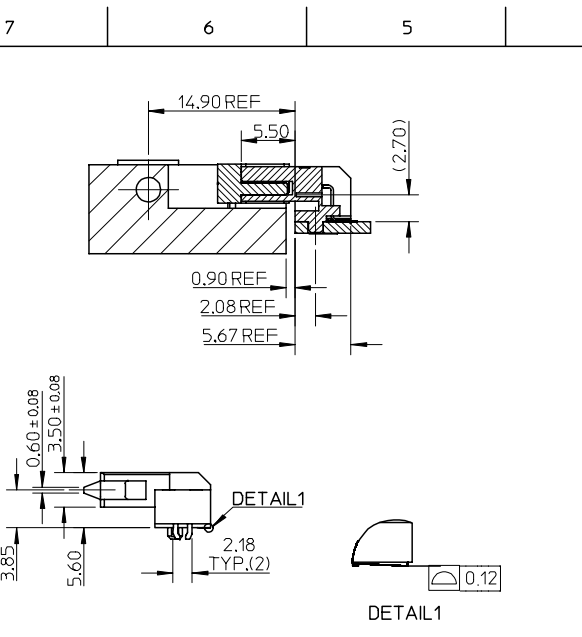
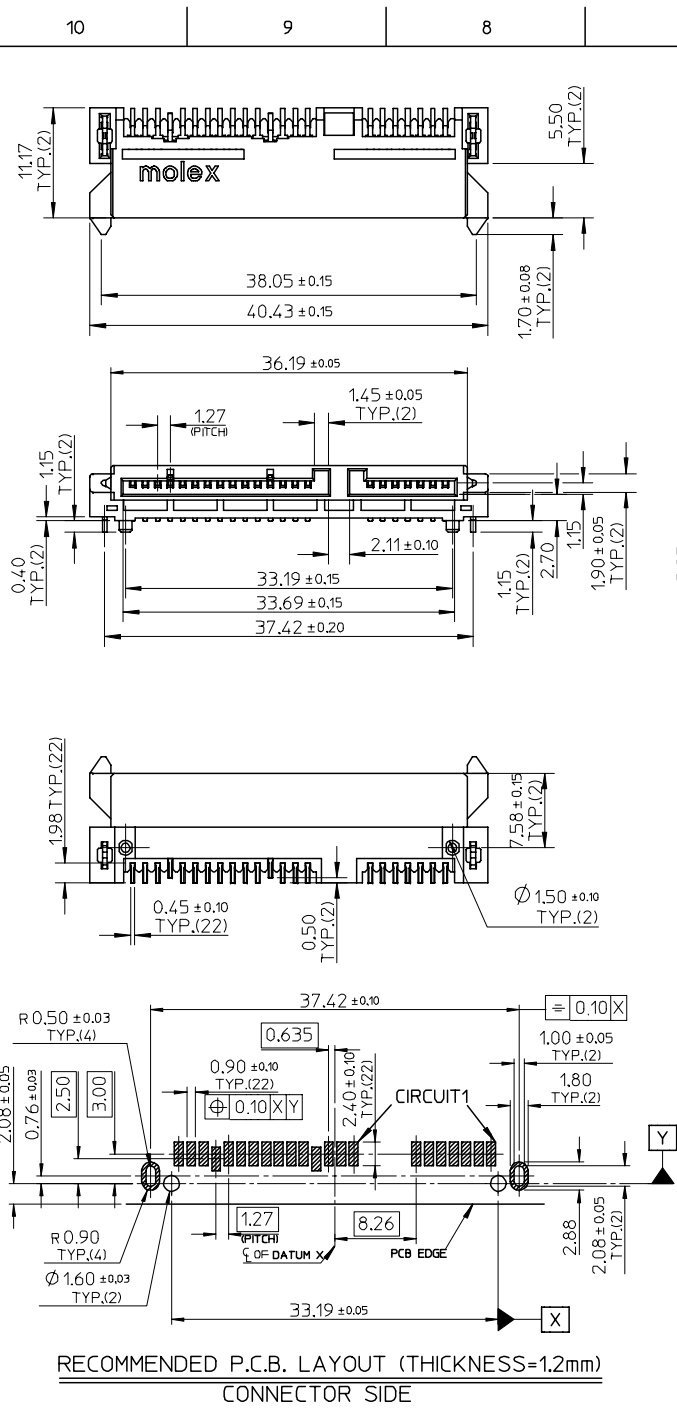

- NOTES:
- MATERIAL:
 - HOUSING: HIGH TEMPERATURE THERMAL PLASTIC, UL94V-0, COLOR: BLACK.
 - TERMINAL: COPPER ALLOY;
 - FORKLOCK: COPPER ALLOY.
 - TERMINAL PLATING :
 - CONTACT AREA:
 - (A) GOLD FLASH;
 - (B) GOLD, THICKNESS=0.76 MICRONS MINIMUM;
 - (C) GOLD, THICKNESS=0.38 MICRONS MINIMUM;
 - SOLDER AREA: TIN, THICKNESS=1.27 MICRONS MINIMUM;
 - UNDER PLATE: NICKEL, THICKNESS=1.27 MICRONS MINIMUM.
 - FORKLOCK PLATING:
 - SOLDER AREA: TIN, THICKNESS=1.27 MICRONS MINIMUM;
 - UNDER PLATE: NICKEL, THICKNESS=1.27 MICRONS MINIMUM.
 - PRODUCT SPECIFICATION: REFER TO PS-67492-001.
 - PACKAGING METHOD: TAPE REEL, DETAIL REFER TO PK-67492-007.
 - MATING PARTS: 87703/87672.

P/N	PLATING	REMARK
67492-1830	NOTES 2 (A)	WITH CAP
67492-1831	NOTES 2 (B)	
67492-1832	NOTES 2 (C)	WITHOUT CAP
67492-1820	NOTES 2 (A)	
67492-1821	NOTES 2 (B)	WITHOUT CAP
67492-1822	NOTES 2 (C)	

RTM	EC NO:	2006/02/08	QUALITY SYMBOLS ▽=0 ◇=0	GENERAL TOLERANCES (UNLESS SPECIFIED)		DIMENSION STYLE MM ONLY		SCALE 2:1	DESIGN UNITS METRIC	THIRD ANGLE PROJECTION
	DRW:GLLI	2006/02/28		mm	INCH	DRAWN BY GRATE MA	DATE 2003/10/10	TITLE SATA HOST RECEPTACLE R/A SMT TYPE -LEAD FREE-		
	CHKD:	2006/03/01		4 PLACES ± --- ± ---	3 PLACES ± --- ± ---	CHECKED BY YA JUN	DATE 2003/10/10	MOLEX MOLEX INCORPORATED		
	APPR:GRMA			2 PLACES ± 0.15 ± ---	1 PLACE ± 0.25 ± ---	APPROVED BY SAM	DATE 2003/10/10		DOCUMENT NO. SD-67492-009	
			ANGULAR ± 3 °	DRAFT WHERE APPLICABLE MUST REMAIN WITHIN DIMENSIONS		SEE TABLE		SHEET NO. 1 OF 1		