



MMDT3946

Preliminary

DUAL TRANSISTOR

COMPLEMENTARY NPN/PNP SMALL SIGNAL SURFACE MOUNT TRANSISTOR

DESCRIPTION

The UTC **MMDT3946** is a complementary NPN/PNP small signal surface mount transistor. It's suitable for low power amplification and switch.

FEATURES

- * Epitaxial Planar Die Construction
- * Extremely-Small Surface Mount Package

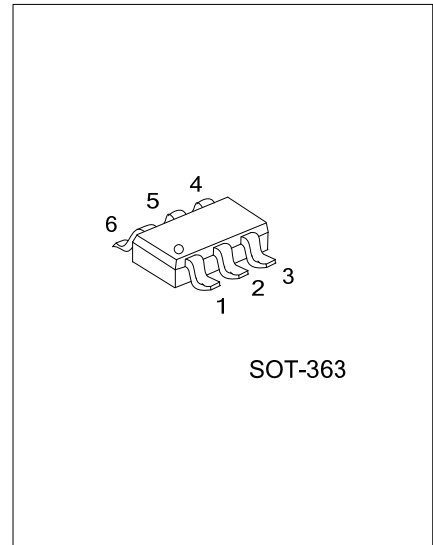

ORDERING INFORMATION

Ordering Number		Package	Packing
Lead Free	Halogen Free		
MMDT3946L-AL6-R	MMDT3946G-AL6-R	SOT-363	Tape Reel

<p>MMDT3946L-AL6-R</p> <p>(1) Packing Type (2) Package Type (3) Lead Free</p>	<p>(1) R: Tape Reel (2) AL6: SOT-363 (3) G: Halogen Free, L: Lead Free</p>
---	--

■ MARKING

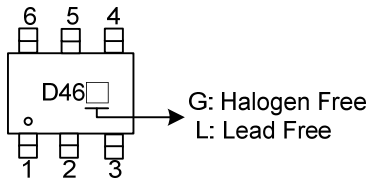

■ PIN CONFIGURATION

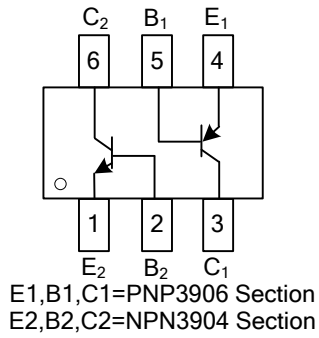

■ ABSOLUTE MAXIMUM RATINGS ($T_A=25^\circ\text{C}$, unless otherwise specified.)

TR1(PNP)

PARAMETER	SYMBOL	RATINGS	UNIT
Collector-Base Voltage	V_{CBO}	-40	V
Collector-Emitter Voltage	V_{CEO}	-40	V
Emitter-Base Voltage	V_{EBO}	-5.0	V
Collector Current-Continuous	I_C	-200	mA
Power Dissipation	P_D	200	mW
Junction Temperature	T_J	+150	$^\circ\text{C}$
Storage Temperature	T_{STG}	-55~+150	$^\circ\text{C}$

Note: Absolute maximum ratings are those values beyond which the device could be permanently damaged. Absolute maximum ratings are stress ratings only and functional device operation is not implied.

TR2(NPN)

PARAMETER	SYMBOL	RATINGS	UNIT
Collector-Base Voltage	V_{CBO}	60	V
Collector-Emitter Voltage	V_{CEO}	40	V
Emitter-Base Voltage	V_{EBO}	6.0	V
Collector Current-Continuous	I_C	200	mA
Power Dissipation	P_D	200	mW
Junction Temperature	T_J	+150	$^\circ\text{C}$
Storage Temperature	T_{STG}	-55~+150	$^\circ\text{C}$

■ THERMAL DATA ($T_A=25^\circ\text{C}$, unless otherwise specified.)

PARAMETER	SYMBOL	RATINGS	UNIT
Junction to Ambient	θ_{JA}	625	$^\circ\text{C/W}$

■ ELECTRICAL CHARACTERISTICS (T_A=25°C, unless otherwise specified.)

TR1(PNP)

PARAMETER	SYMBOL	TEST CONDITIONS	MIN	TYP	MAX	UNIT
OFF CHARACTERISTICS (Note 1)						
Collector-Base Breakdown Voltage	V _{(BR)CBO}	I _C =-10μA, I _E =0	-40			V
Collector-Emitter Breakdown Voltage	V _{(BR)CEO}	I _C =-1.0mA, I _B =0	-40			V
Emitter-Base Breakdown Voltage	V _{(BR)EBO}	I _E =-10μA, I _C =0	-5.0			V
Collector Cutoff Current	I _{CEX}	V _{CE} =-30V, V _{EB(OFF)} =-3.0V			-50	nA
Base Cutoff Current	I _{BL}	V _{CE} =-30V, V _{EB(OFF)} =-3.0V			-50	nA
ON CHARACTERISTICS (Note 1)						
DC Current Gain	h _{FEF}	I _C =-100μA, V _{CE} =-1.0V	60			
		I _C =-1.0mA, V _{CE} =-1.0V	80			
		I _C =-10mA, V _{CE} =-1.0V	100		300	
		I _C =-50mA, V _{CE} =-1.0V	60			
		I _C =-100mA, V _{CE} =-1.0V	30			
Collector-Emitter Saturation Voltage	V _{CE(SAT)}	I _C =-10mA, I _B =-1.0mA			-0.25	V
		I _C =-50mA, I _B =-5.0mA			-0.40	
Base-Emitter Saturation Voltage	V _{BE(SAT)}	I _C =-10mA, I _B =-1.0mA	-0.65		-0.85	V
		I _C =-50mA, I _B =-5.0mA			-0.95	
SMALL SIGNAL CHARACTERISTICS						
Output Capacitance	C _{OBO}	V _{CB} =-5.0V, f=1.0MHz, I _E =0			4.5	pF
Input Capacitance	C _{IBO}	V _{EB} =-0.5V, f=1.0MHz, I _C =0			10	pF
Input Impedance	h _{IE}	V _{CE} =10V, I _C =1.0mA, f=1.0kHz	2.0		12	kΩ
Voltage Feedback Ratio	h _{RE}		0.1		10	×10 ⁻⁴
Small Signal Current Gain	h _{FE}		100		400	
Output Admittance	h _{OE}		3.0		60	μS
Current Gain-Bandwidth Product	f _T		V _{CE} =-20V, I _C =-10mA, f=100MHz	250		
Noise Figure	NF	V _{CE} =-5.0V, I _C =-100μA, R _S =1.0kΩ, f=1.0kHz			4.0	dB
SWITCHING CHARACTERISTICS						
Delay Time	t _D	V _{CC} =-3.0V, I _C =-10mA,			35	ns
Rise Time	t _R	V _{BE(OFF)} =0.5V, I _{B1} =-1.0mA			35	ns
Storage Time	t _S	V _{CC} =-3.0V, I _C =-10mA,			225	ns
Fall Time	t _F	I _{B1} =I _{B2} =-1.0mA			75	ns

Note: 1. Short duration pulse test used to minimize self-heating effect.

■ ELECTRICAL CHARACTERISTICS(Cont.)(T_A=25°C,unless otherwise specified.)

TR2(NPN)

PARAMETER	SYMBOL	TEST CONDITIONS	MIN	TYP	MAX	UNIT
OFF CHARACTERISTICS (Note 1)						
Collector-Base Breakdown Voltage	V _{(BR)CBO}	I _C =10μA, I _E =0	60			V
Collector-Emitter Breakdown Voltage	V _{(BR)CEO}	I _C =1.0mA, I _B =0	40			V
Emitter-Base Breakdown Voltage	V _{(BR)EBO}	I _E =10μA, I _C =0	5.0		6.0	V
Collector Cutoff Current	I _{CEX}	V _{CE} =30V, V _{EB(OFF)} =3.0V			50	nA
Base Cutoff Current	I _{BL}	V _{CE} =30V, V _{EB(OFF)} =3.0V			50	nA
ON CHARACTERISTICS (Note 1)						
DC Current Gain	h _{FE}	I _C =100μA, V _{CE} =1.0V	40			
		I _C =1.0mA, V _{CE} =1.0V	70			
		I _C =10mA, V _{CE} =1.0V	100		300	
		I _C =50mA, V _{CE} =1.0V	60			
		I _C =100mA, V _{CE} =1.0V	30			
Collector-Emitter Saturation Voltage	V _{CE(SAT)}	I _C =10mA, I _B =1.0mA			0.20	V
		I _C =50mA, I _B =5.0mA			0.30	
Base-Emitter Saturation Voltage	V _{BE(SAT)}	I _C =10mA, I _B =1.0mA	0.65		0.85	V
		I _C =50mA, I _B =5.0mA			0.95	
SMALL SIGNAL CHARACTERISTICS						
Output Capacitance	C _{OBO}	V _{CB} =5.0V, f=1.0MHz, I _E =0			4.0	pF
Input Capacitance	C _{IBO}	V _{EB} =0.5V, f=1.0MHz, I _C =0			8.0	pF
Input Impedance	h _{IE}	V _{CE} =10V, I _C =1.0mA, f=1.0kHz	1.0		10	kΩ
Voltage Feedback Ratio	h _{RE}		0.5		8.0	×10 ⁻⁴
Small Signal Current Gain	h _{FE}		100		400	
Output Admittance	h _{OE}		1.0		40	μS
Current Gain-Bandwidth Product	f _T		V _{CE} =20V, I _C =20mA, f=100MHz	300		
Noise Figure	NF	V _{CE} =5.0V, I _C =100μA, R _S =1.0kΩ, f=1.0kHz			5.0	dB
SWITCHING CHARACTERISTICS						
Delay Time	t _D	V _{CC} =3.0V, I _C =10mA,			35	ns
Rise Time	t _R	V _{BE(OFF)} =-0.5V, I _{B1} =1.0mA			35	ns
Storage Time	t _S	V _{CC} =3.0V, I _C =10mA,			200	ns
Fall Time	t _F	I _{B1} =I _{B2} =1.0mA			50	ns

Note: 1. Short duration pulse test used to minimize self-heating effect.

UTC assumes no responsibility for equipment failures that result from using products at values that exceed, even momentarily, rated values (such as maximum ratings, operating condition ranges, or other parameters) listed in products specifications of any and all UTC products described or contained herein. UTC products are not designed for use in life support appliances, devices or systems where malfunction of these products can be reasonably expected to result in personal injury. Reproduction in whole or in part is prohibited without the prior written consent of the copyright owner. The information presented in this document does not form part of any quotation or contract, is believed to be accurate and reliable and may be changed without notice.