

SPECIFICATION FOR LCD MODULE

Model No. TM48064BDA

Prepared by:	Date:
Checked by :	Date:
Verified by :	Date:
Approved by:	Date:

TIANMA MICROELECTRONICS CO., LTD

Rev. 1.0

REVISION RECORD

Date	Ver.	Ref. Page.	Revision No.	Revision Item

1. General Specifications:

- 1.1 Display type: STN
- 1.2 Display color*:
 - Display color: Dark Blue
 - Background : Gray
- 1.3 Polarizer mode: Reflective/Positive
- 1.4 Viewing Angle: 6:00
- 1.5 Driving Method: 1/64 Duty 1/9 Bias
- 1.6 LCD Operation Voltage: 14.2V
- 1.7 V_{DD}: 5.0V
- 1.8 Backlight: Without
- 1.9 Driver: S6B0086X01-Q0RJ
- 1.10 Data Transfer: 1-Bits Serial Date Input
- 1.11 Operating Temperature: 0----+50
Storage Temperature: -20----+60
- 1.12 Outline Dimensions: Refer to outline drawing on next page
- 1.13 Dot Matrix: 480 × 64 DOTS
- 1.14 Dot Size: 0.40 × 0.45 (mm)
- 1.15 Dot Pitch: 0.45 × 0.50 (mm)
- 1.16 Weight: 195g (Approx)

* Color tone is slightly changed by temperature and driving voltage.

2. Outline Drawing

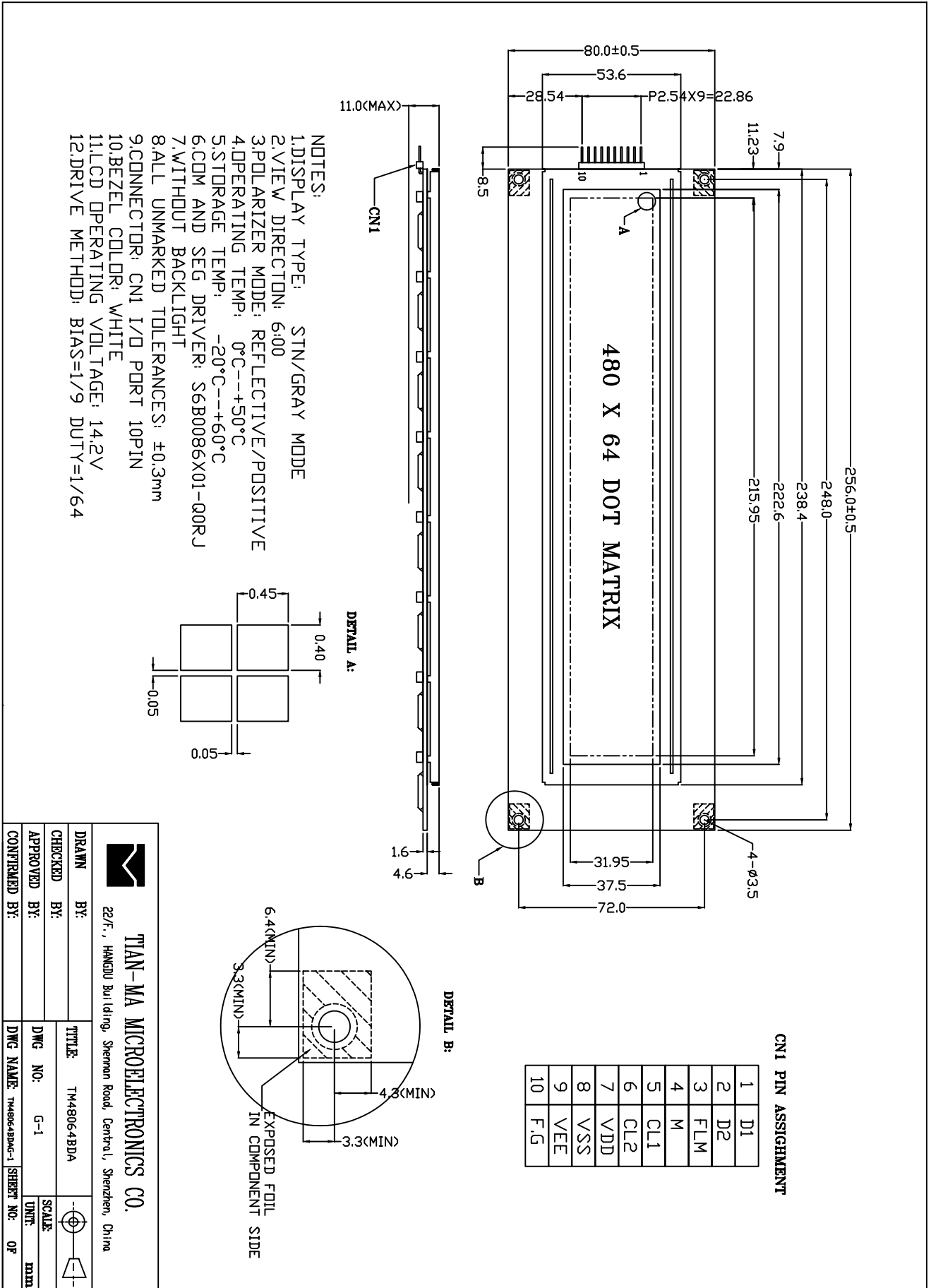

TM-MICROELECTRONICS CO.
 22/F., HANGUO Building, Sherman Road, Central, Shenzhen, China

DRAWN BY:	TITLE:	TM48064BDA	SCALE:	1:1
CHECKED BY:	DWG NO:	G-1	UNIT:	mm
APPROVED BY:	DWG NAME:	TM48064BDA-1	SHEET NO:	01
CONTRIMED BY:				

3. LCD Module Part Numbering System

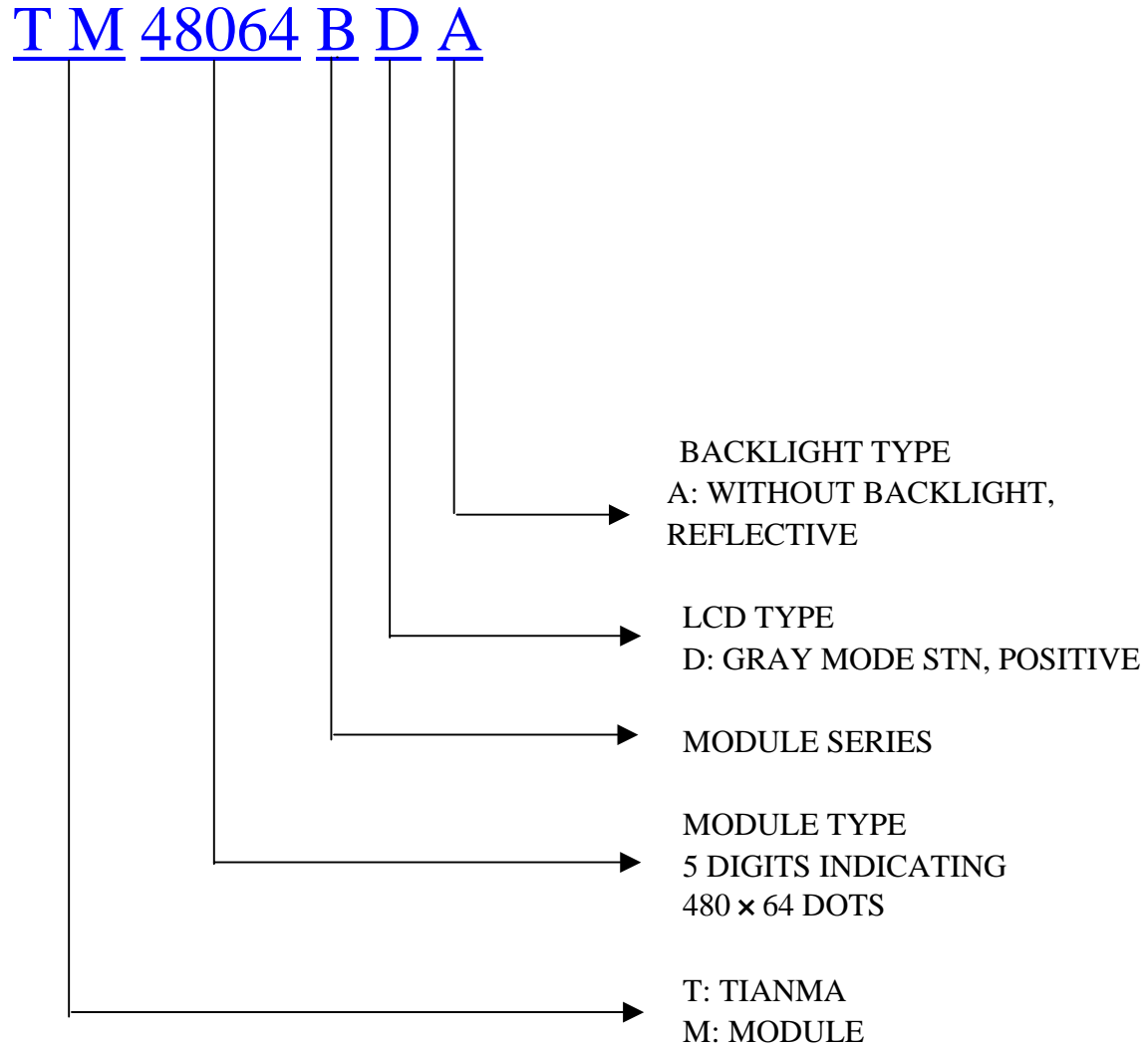

4. Circuit Block Diagram

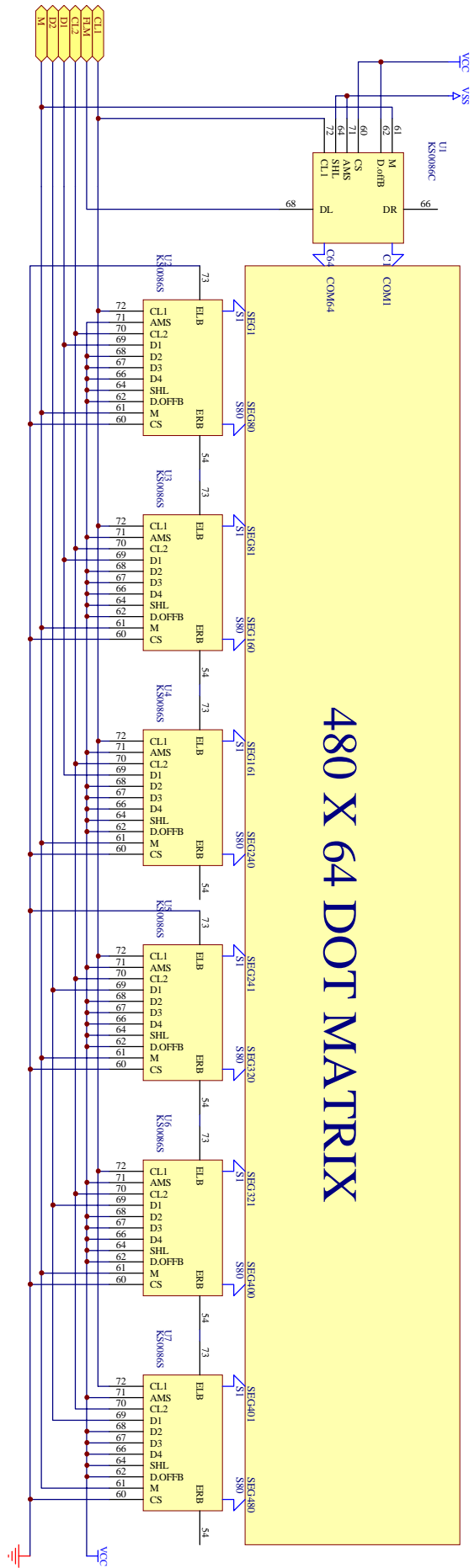
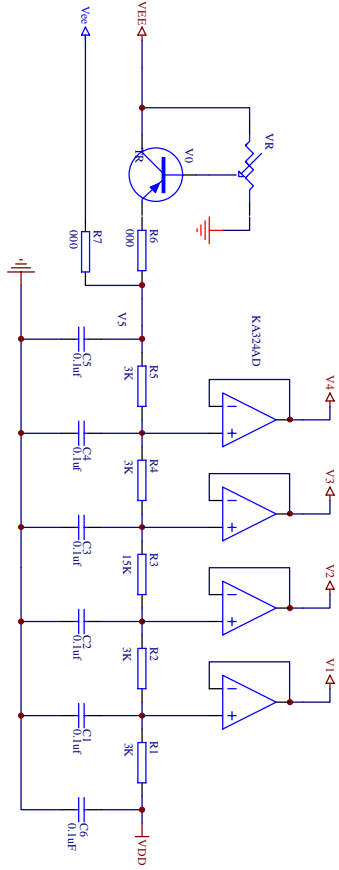

5. Absolute Maximum Ratings

Item	Symbol	Min.	Max.	Unit	Remark
Power Supply Voltage	$V_{DD} - V_{SS}$	-0.3	6.0	V	
LCD Driving Voltage	V_{LCD}	-	25.0		
Operating Temperature Range	T_{OP}	0	+50		No Condensation
Storage Temperature Range	T_{ST}	-20	+60		

6. Electrical Specifications and Instruction Code

6.1 Electrical characteristics

Item		Symbol	Min.	Typ.	Max.	Unit
Supply Voltage (Logic)		$V_{DD} - V_{SS}$	4.75	5.0	5.25	V
Supply Voltage (LCD Drive)		V_{LCD}	13.2	14.2	15.2	V
Input Signal Voltage	High	V_{IH} ($V_{DD}=5.0$)	$0.8V_{DD}$	-	$V_{DD}+0.3$	V
	Low	V_{IL} ($V_{DD}=5.0$)	0	-	$0.2V_{DD}$	V
Supply current (Logic)		I_{DD} ($V_{DD} - V_{SS} =5.0$)	-	3.3	7.0	mA
Supply current (LCD Drive)		I_{EE}	-	2.9	5.8	mA

6.2 Interface Signals

Pin No.	Symbol	Level	Description
1	D1	H/L	Display Date(Left screen date)
2	D2	H/L	Display Date(Right screen date)
3	FLM	H/L	Indicate the beginning of each frame
4	M	H/L	AC signal for LCD driver output
5	CL1	H/L	Date latch pulse
6	CL2	H/L	Date shift clock pulse
7	VDD	5.0V	Power supply voltage for logic and LCD(+)
8	VSS	0V	Ground
9	VEE	-9.2V	Power supply voltage for LCD(-)
10	F.G	0V	Frame Ground

6.3 Interface Timing Chart

(1) Segment driver application

AC CHARACTERISTICS SEGMENT DRIVER APPLICATION

(V_{SS} = 0 V, T_a = -30 ~ +85°C)

Characteristic	Symbol	Test Condition	(1) VDD=5 V ± 10%			(2) VDD=3 V ± 10%			Unit
			MIN	TYP	MAX	MIN	TYP	MAX	
Clock cycle time	t _{CY}	Duty=50%	125	-	-	250	-	-	ns
Clock pulse width	t _{WCK}	-	45	-	-	95	-	-	
Clock rise/fall time	t _{R/F}	-	-	-	-	-	-	30	
Data set-up time	t _{DS}	-	30	-	-	65	-	-	
Data hold time	t _{DH}	-	30	-	-	65	-	-	
Clock set-up time	t _{CS}	-	80	-	-	120	-	-	
Clock hold time	t _{CH}	-	80	-	-	120	-	-	
Propagation delay time	t _{PHL}	ELB Output	-	-	60	-	-	125	
		ERB Output	-	-	60	-	-	125	
ELB,ERB set-up time	t _{PSU}	ELB Input	30	-	-	65	-	-	
		ERB Input	30	-	-	65	-	-	
DISPOFFB low pulse width	t _{WDL}	-	1.2	-	-	1.2	-	-	μs
DISPOFFB clear time	t _{CD}	-	100	-	-	100	-	-	ns
M - OUT propagation delay time	t _{PD1}	CL=15 pF	-	-	1.0	-	-	1.2	μs
CL1 - OUT propagation delay time	t _{PD2}		-	-	1.0	-	-	1.2	
DISPOFFB - OUT propagation delay time	t _{PD3}		-	-	1.0	-	-	-	

AC CHARACTERISTICS (continued)

SEGMENT DRIVER APPLICATION TIMING

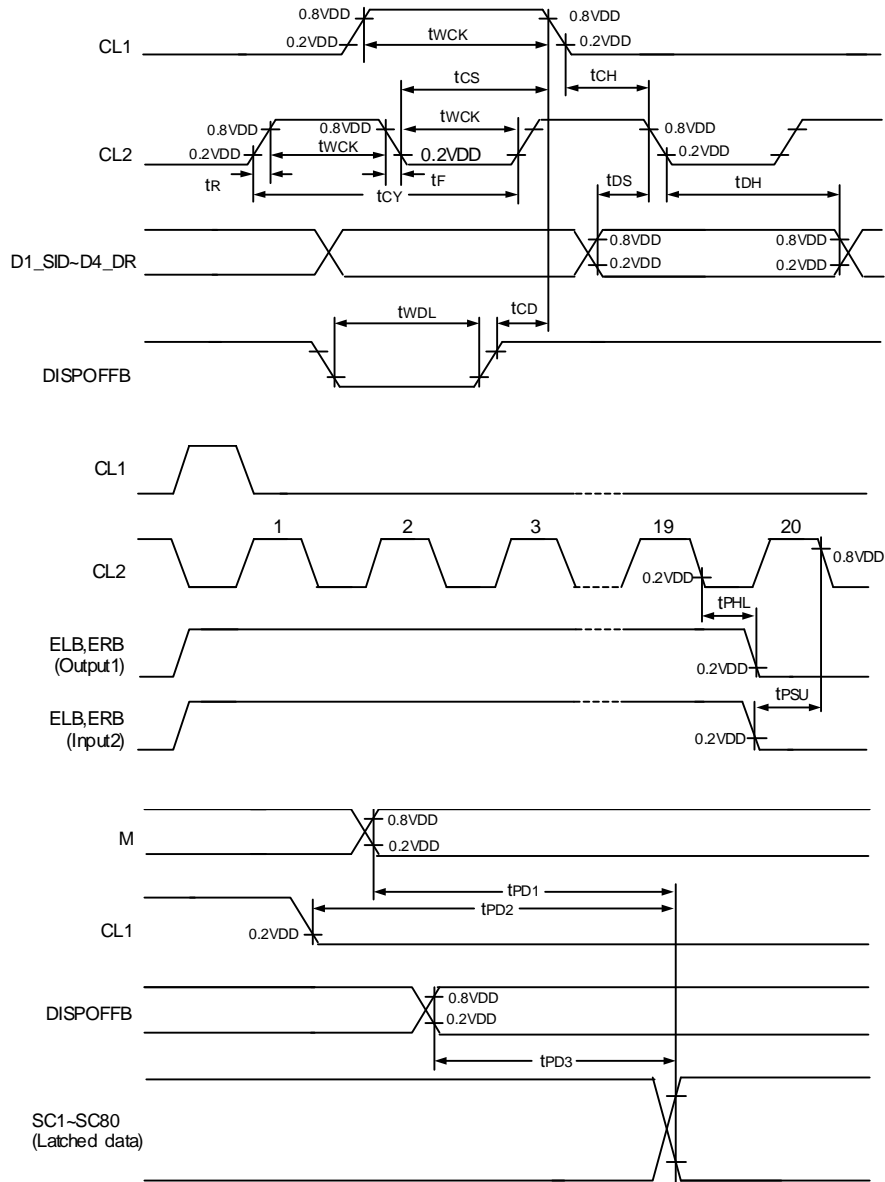

(2) Common driver application

AC CHARACTERISTICS (continued)

COMMON DRIVER APPLICATION

(V_{SS} = 0 V, T_a = -30 ~ +85°C)

Characteristic	Symbol	Test Condition	(1) VDD=5 V ± 10%			(2) VDD=3V±10%			Unit
			MIN	TYP	MAX	MIN	TYP	MAX	
Clock cycle time	t _{CY}	Duty=50%	250	-	-	500	-	-	ns
Clock pulse width	t _{WCK}	-	45	-	-	95	-	-	
Clock rise/fall time	t _{R/F}	-	-	-	50	-	-	50	
Data set-up time	t _{DS}	-	30	-	-	65	-	-	
Data hold time	t _{DH}	-	30	-	-	65	-	-	
DISPOFFB low pulse width	t _{WDL}	-	1.2	-	-	1.2	-	-	μs
DISPOFFB clear time	t _{CD}	-	100	-	-	100	-	-	ns
Output delay time	t _{DL}	CL=15 pF	-	-	200	-	-	250	μs
M - OUT propagation delay time	t _{PD1}		-	-	1.0	-	-	1.2	
CL1 - OUT propagation delay time	t _{PD2}		-	-	1.0	-	-	1.2	
DISPOFFB - OUT propagation delay time	t _{PD3}		-	-	1.0	-	-	1.2	

AC CHARACTERISTICS (continued)

COMMON DRIVER APPLICATION TIMING

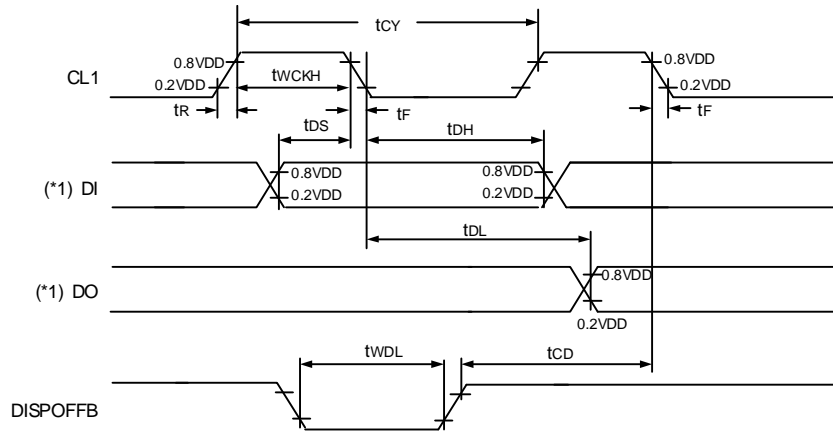

(*1) When in single-type interface mode
 DI ⇒ D2_DL(SHL="L"), D4_DR(SHL="H")
 DO ⇒ D4_DR(SHL="L"), D2_DL(SHL="H")
 When in dual-type interface mode
 DI ⇒ D2_DL and D3_DM(SHL="L"), D4_DR and D3_DM(SHL="H")
 DO ⇒ D4_DR(SHL="L"), D2_DL(SHL="H")

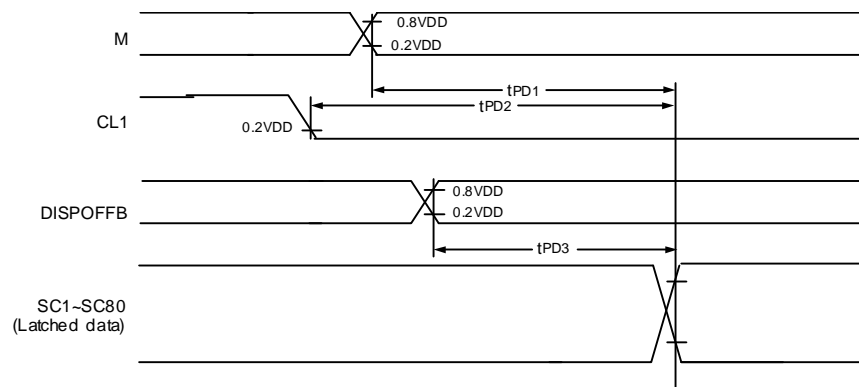

7. Optical Characteristics

7.1 Optical Characteristics

Ta=25

Item	Symbol	Condition	Min.	Typ.	Max.	Unit		
Viewing Angle	x	Cr≥2	y=0 °		-30	--	20	Deg
	y		x=0 °		-30	--	30	
Contrast Ratio	Cr	x=0 ° y=0 °	3.0	-	-			
Response Time	Turn on	T _{on}	x=0 ° y=0 °	-	-	300	ms	
	Turn off	T _{off}		-	-	300		

7.2 Definition of Optical Characteristics

7.2.1 Definition of Viewing Angle

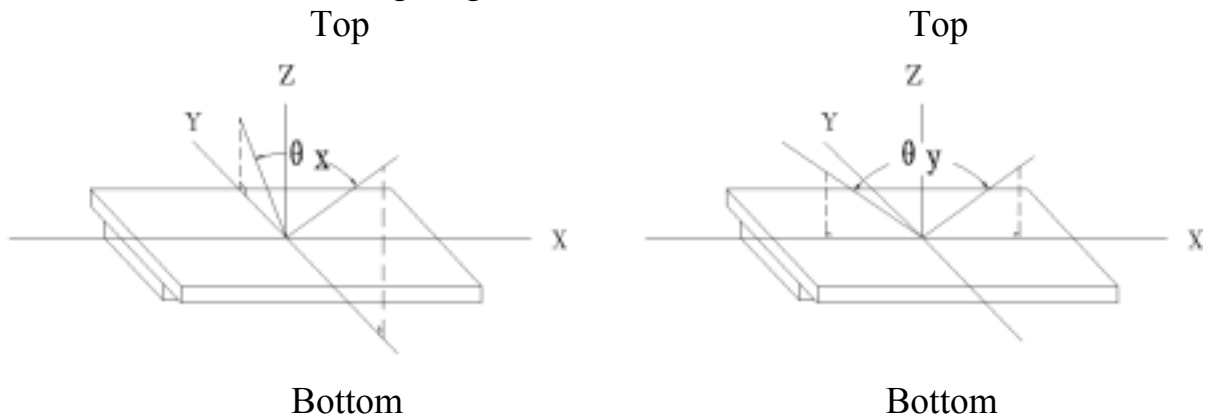

7.2.2 Definition of Contrast Ratio

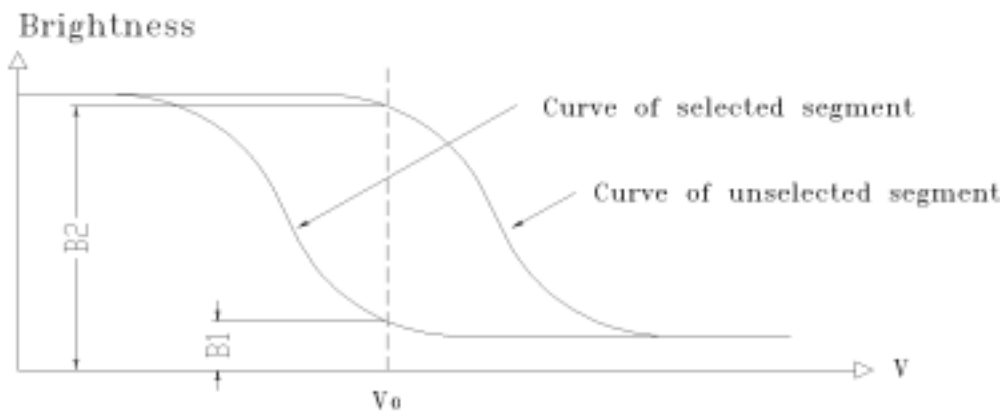

$$\text{Contrast Ratio} = B2/B1 = \frac{\text{unselected state brightness}}{\text{selected state brightness}}$$

Measuring Conditions:

- 1) Ambient Temperature: 25 ;
- 2) Frame frequency: 64Hz

7.2.3 Definition of Response time

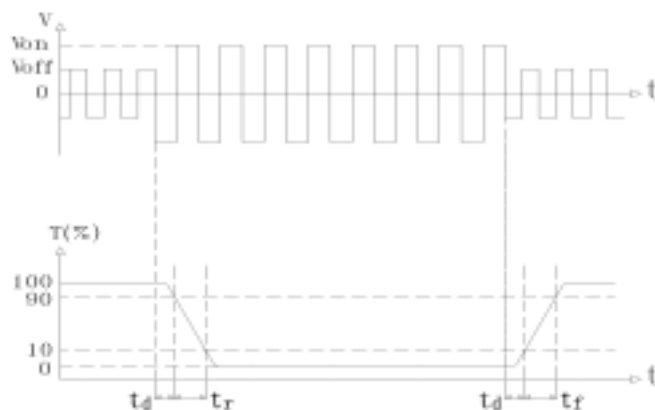

Turn on time: $t_{on} = t_d + t_r$ Turn off time: $t_{off} = t_d + t_f$

Measuring Condition:

- 1) Operating Voltage: 14.2V
- 2) Frame frequency: 64Hz

8. Reliability

8.1 Content of Reliability Test

Ta=25

No.	Test Item	Content of Test	Test condition
1	High Temperature Storage	Endurance test applying the high storage temperature for a long time	60 96H
2	Low Temperature Storage	Endurance test applying the low storage temperature for a long time	-20 96H
3	High Temperature Operation	Endurance test applying the electric stress (voltage & current) and the thermal stress to the element for a long time	50 96H
4	Low Temperature Operation	Endurance test applying the electric stress under low temperature for a long time	0 960H
5	High Temperature /Humidity Storage	Endurance test applying the high temperature and high humidity storage for a long time	40 95%RH 240H
6	Temperature Cycle	Endurance test applying the low and high temperature cycle -20 25 60 25 30min 5min 30min 5min 1 cycle	-20 /60 10 cycles
7	Vibration Test (package state)	Endurance test applying the vibration during transportation	10Hz~150Hz, 50m/s ² , 40min
8	Shock Test (package state)	Endurance test applying the shock during transportation	Half- sine wave, 100m/s ² , 11ms
9	Atmospheric Pressure Test	Endurance test applying the atmospheric pressure during transportation by air	40kPa 16H

8.2 Failure Judgment Criterion

Criterion Item	Test Item No.									Failure Judgement Criterion
	1	2	3	4	5	6	7	8	9	
Basic Specification	√	√	√	√	√	√	√	√	√	Out of the basic Specification
Electrical specification	√	√	√	√	√					Out of the electrical specification
Mechanical Specification							√	√		Out of the mechanical specification
Optical Characteristic	√	√	√	√	√	√			√	Out of the optical specification
Note	For test item refer to 8.1									
Remark	Basic specification = Optical specification + Mechanical specification									

9. QUALITY LEVEL

Examination or Test	At Ta=25 (unless otherwise stated)	Inspection				
		Min.	Max.	Unit	IL	AQL
External Visual Inspection	Under normal illumination and eyesight condition, the distance between eyes and LCD is 25cm.	See Appendix A			II	Major 1.0 Minor 2.5
Display Defects	Under normal illumination and eyesight condition, display on inspection.	See Appendix B			II	Major 1.0 Minor 2.5
<p>Note: Major defects: Open segment or common, Short, Serious damages, Leakage Miner defects: Others Sampling standard conforms to GB2828</p>						

10. Precautions for Use of LCD Modules

10.1 Handling Precautions

10.1.1 The display panel is made of glass. Do not subject it to a mechanical shock by dropping it from a high place, etc.

10.1.2 If the display panel is damaged and the liquid crystal substance inside it leaks out, be sure not to get any in your mouth, if the substance comes into contact with your skin or clothes, promptly wash it off using soap and water.

10.1.3 Do not apply excessive force to the display surface or the adjoining areas since this may cause the color tone to vary.

10.1.4 The polarizer covering the display surface of the LCD module is soft and easily scratched. Handle this polarizer carefully.

10.1.5 If the display surface is contaminated, breathe on the surface and gently wipe it with a soft dry cloth. If still not completely clear, moisten cloth with one of the following solvents:

- Isopropyl alcohol
- Ethyl alcohol

Solvents other than those mentioned above may damage the polarizer. Especially, do not use the following:

- Water
- Ketone
- Aromatic solvents

10.1.6 Do not attempt to disassemble the LCD Module.

10.1.7 If the logic circuit power is off, do not apply the input signals.

10.1.8 To prevent destruction of the elements by static electricity, be careful to maintain an optimum work environment.

- a. Be sure to ground the body when handling the LCD Modules.
- b. Tools required for assembly, such as soldering irons, must be properly ground.
- c. To reduce the amount of static electricity generated, do not conduct assembly and other work under dry conditions.
- d. The LCD Module is coated with a film to protect the display surface. Be care when peeling off this protective film since static electricity may be generated.

10.2 Storage precautions

10.2.1 When storing the LCD modules, avoid exposure to direct sunlight or to the light of fluorescent lamps.

10.2.2 The LCD modules should be stored under the storage temperature range. If the LCD modules will be stored for a long time, the recommend condition is:

Temperature : 0 ~ 40



Relatively humidity: 80%

10.2.3 The LCD modules should be stored in the room without acid, alkali and harmful gas.

10.3 The LCD modules should be no falling and violent shocking during transportation, and also should avoid excessive press, water, damp and sunshine.

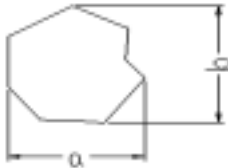

Appendix A

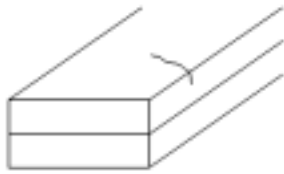
Inspection items and criteria for appearance defects

Items	Contents	Criteria		
Leakage		Not permitted		
Rainbow		According to the limit specimen		
Polarizer	Wrong polarizer attachment	Not permitted		
	Bubble between polarizer and glass	Not counted	Max. 3 defects allowed	
		$\phi < 0.3\text{mm}$	0.3mm ϕ 0.5mm	
Scratches of polarizer	According to the limit specimen			
Black spot (in viewing area)		Not counted	Max. 3 spots allowed	
		$X < 0.2\text{mm}$	0.2mm X 0.5mm	
		$X = (a+b)/2$		
Black line (in viewing area)		Not counted	Max. 3 lines allowed	
		$a < 0.02\text{mm}$	0.02mm a 0.05mm b 2.0mm	
Progressive cracks		Not permitted		

Appendix B

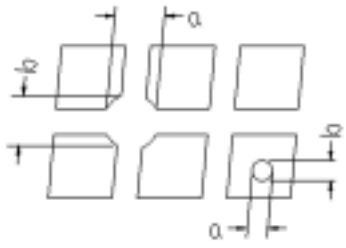
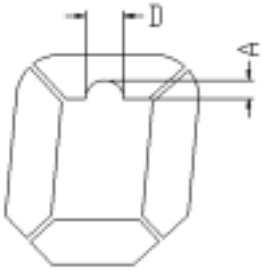
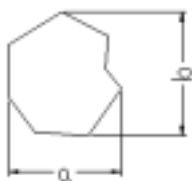
Inspection items and criteria for display defects

Items	Contents	Criteria			
Open segment or open common		Not permitted			
Short		Not permitted			
Wrong viewing angle		Not permitted			
Contrast ratio uneven		According to the limit specimen			
Crosstalk		According to the limit specimen			
Pin holes and cracks in segment (DOT)		Not counted	Max.3 dots allowed		Max.3 dots allowed
		$X < 0.1\text{mm}$	0.1mm X 0.2mm		
		$X = (a+b)/2$			
		Not counted	Max.2 dots allowed		
$A < 0.1\text{mm}$		0.1mm A 0.2mm $D < 0.25\text{mm}$			
Black spot (in viewing area)		Not counted	Max.3 spots allowed		Max.3 spots (lines) allowed
		$X < 0.1\text{mm}$	0.1mm X 0.2mm		
		$X = (a+b)/2$			
Black line (in viewing area)		Not counted	Max.3 lines allowed		
		$a < 0.02\text{mm}$	0.02mm a 0.05mm b 0.5mm		

Appendix B

Inspection items and criteria for display defects (continued)

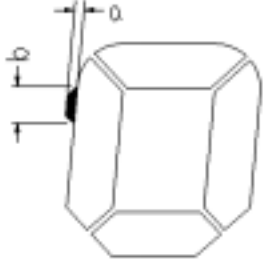
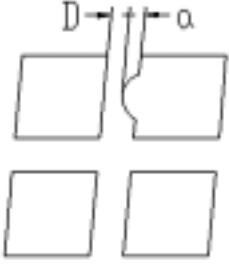
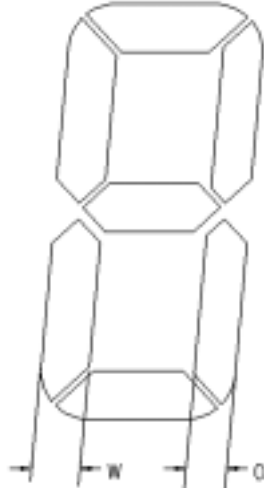
Items	Content	Criteria				
Transformation of segment		Not counted	Max. 2 defects allowed	Max.3 defects allowed		
		$x < 0.1\text{mm}$	$0.1\text{mm} \leq x \leq 0.2\text{mm}$			
		$x = (a+b)/2$				
		Not counted	Max. 1 defects allowed			
		$a < 0.1\text{mm}$	$0.1\text{mm} \leq a \leq 0.2\text{mm}$ $D > 0$			
		Max.2 defects allowed $0.8W \leq a \leq 1.2W$ $a = \text{measured value of width}$ $W = \text{nominal value of width}$				